

**High flux polarized
gamma production:
status of the LAL 4 mirrors cavity
at the ATF**

Nicolas Delerue

LAL (CNRS) and Université de Paris-Sud
on behalf of the Mighty Laser collaboration

The MightyLaser team (French-Japanese collaboration)

F. Labaye, E. Cormier, CELIA CNRS Université Bordeaux 1, Bordeaux, France
T. Akagai, S. Miyosohi, S. Nagata, T. Takahashi, Hishoshima University Hiroshima, Japan
S. Araki, S. Funahashi, Y. Honda, T. Omori, H. Shimizu, T. Terunuma, J. Urakawa, KEK, Tsukuba, Japan
J. Bonis, R. Chiche, R. Cizeron, M. Cohen, J. Colin, E. Cormier, P. Cornebise, D. Jehanno, F. Labaye, M. Lacroix,
Y. Peinaud, V. Soskov, A. Variola, F. Zomer, LAL CNRS/IN2P3 Université Paris-Sud 11, Orsay, France
R. Flaminio, L. Pinard, LMA CNRS/IN2P3, Lyon, France

+ Iryna Chaikovska & Nicolas Delerue (LAL)

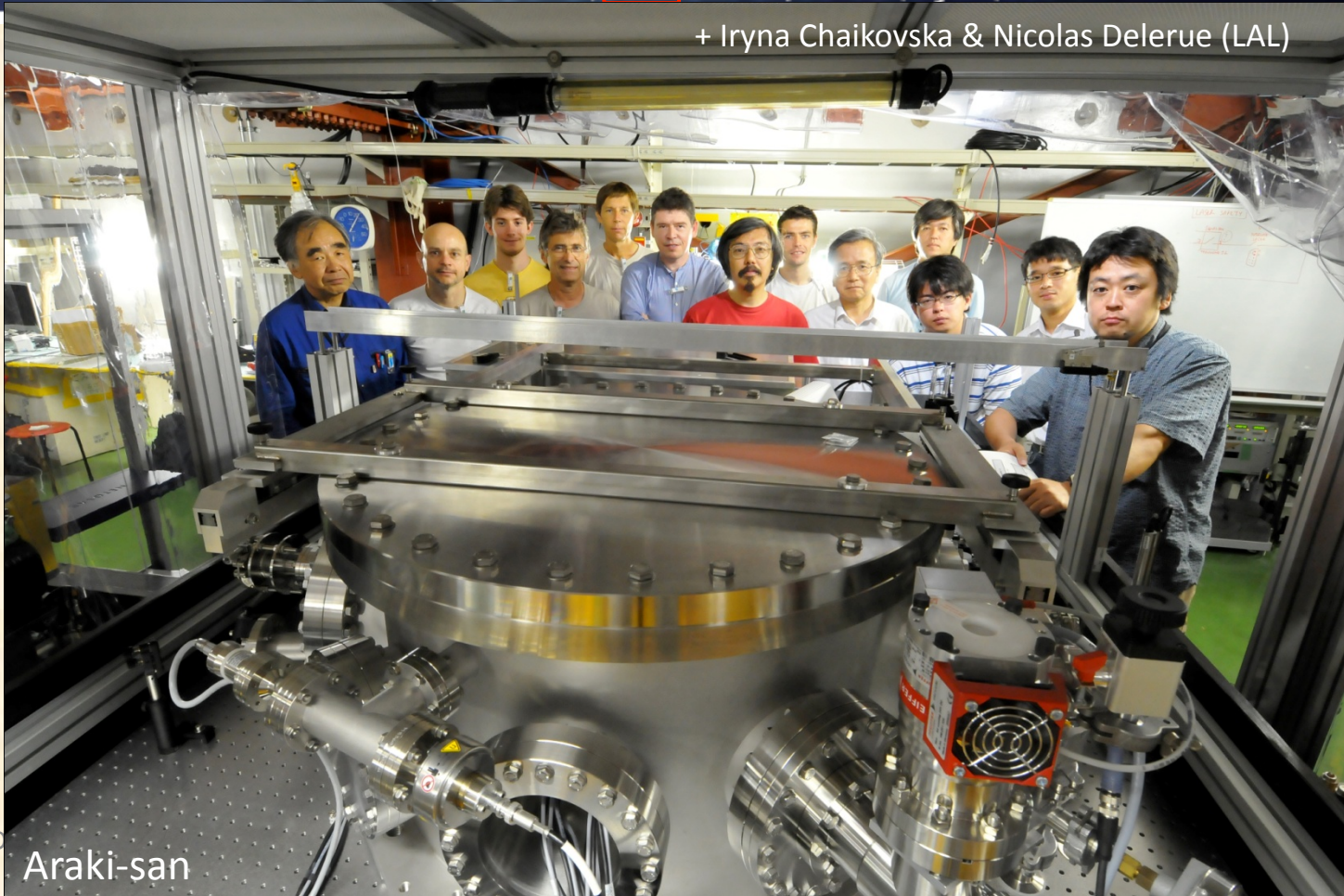

Nicolas D

Araki-san

2

Mighty Laser overview

- The aim of mighty laser is to demonstrate that high flux of gamma rays can be produced by Compton scattering.
- This can be applied to the production of polarised positrons for a linear collider but also to compact X-ray sources such as the ThomX project in France.
- This experiment is done in the damping ring of the KEK ATF (1.28 GeV electrons).
- Laser power is enhanced by stacking in a cavity.
- Collisions occur at about 1MHz.

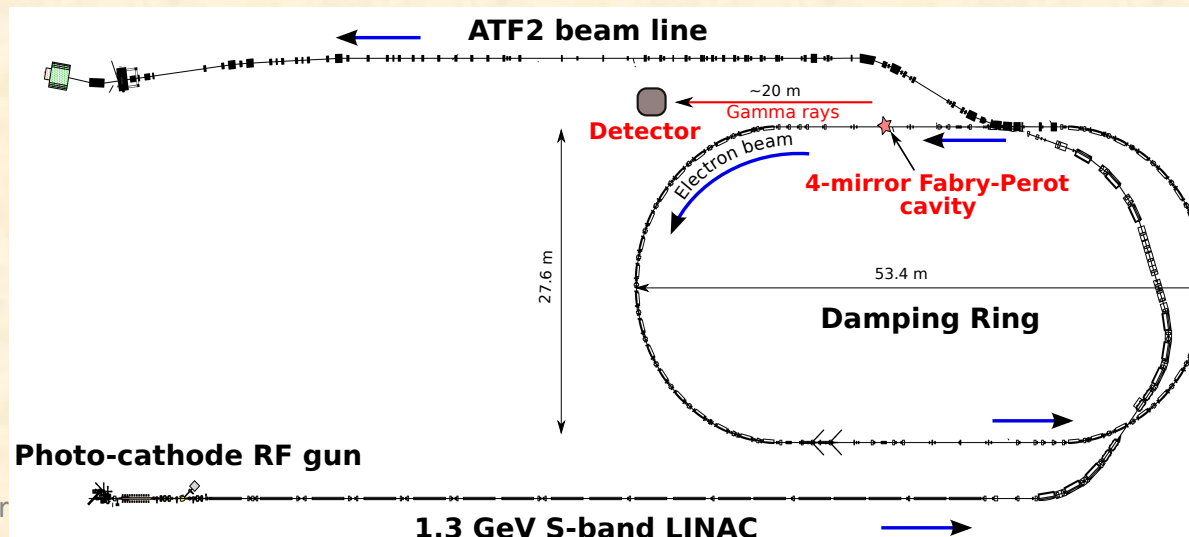

Compton scattering for polarised positrons

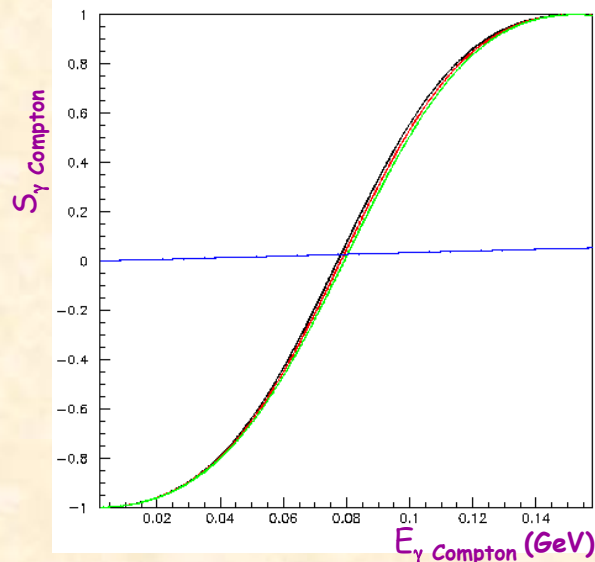
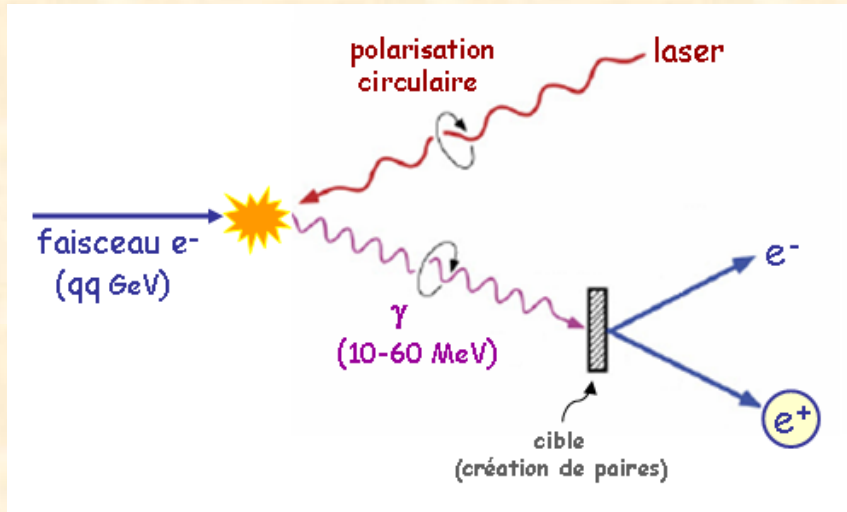

- Circularly polarised gammas can be sent on a target to produce polarised e^+/e^- pairs.
- The high energy gammas produced in Compton scattering have the same polarisation than the incident laser.
- The angular distribution of the gammas depends on their energy.
- Hence Compton scattering can be used to “transfer” the polarisation from the laser to positrons.

Experimental proof at ATF

- Omori et al. PRL 96(2006)114801

Laser pulses stacking

- Compton cross-section is very small
=> important to recycle laser and electrons (laser cavity and electron ring) .
- However this requires that each laser pulse arrives in phase with those already stacked in the cavity
=> feedback system needed between the seed laser and the cavity.
- Furthermore the laser pulse must cross the IP at the same time than the electrons
=> second feedback loop needed.

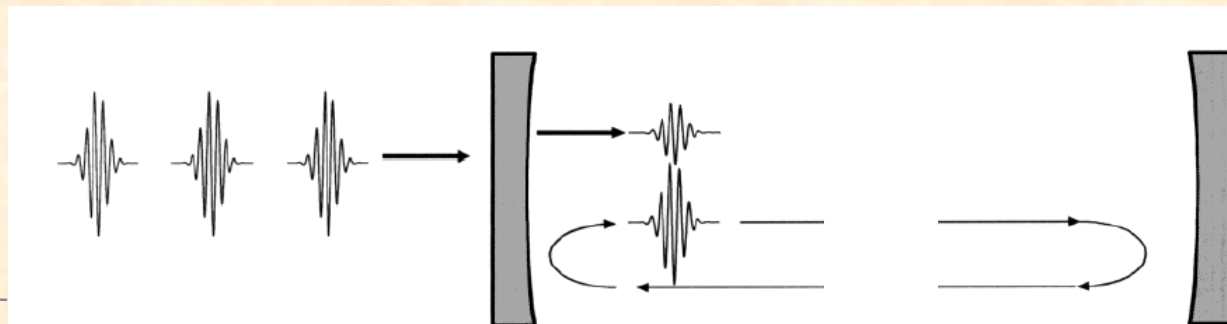

The cavity

- A 4-mirrors non planar cavity is used to stack laser pulses.
- Length: 1.68m \Rightarrow $f=178.5\text{MHz}$ ($f_{\text{ATF}}/2$)
- A non-planar geometry ensures that the laser pulses are polarised circularly.
- The current finesse (stacking power) of the cavity is about 3000 (gain 1000) but an upgrade to 30 000 is foreseen.
- Installed at KEK during summer 2010.

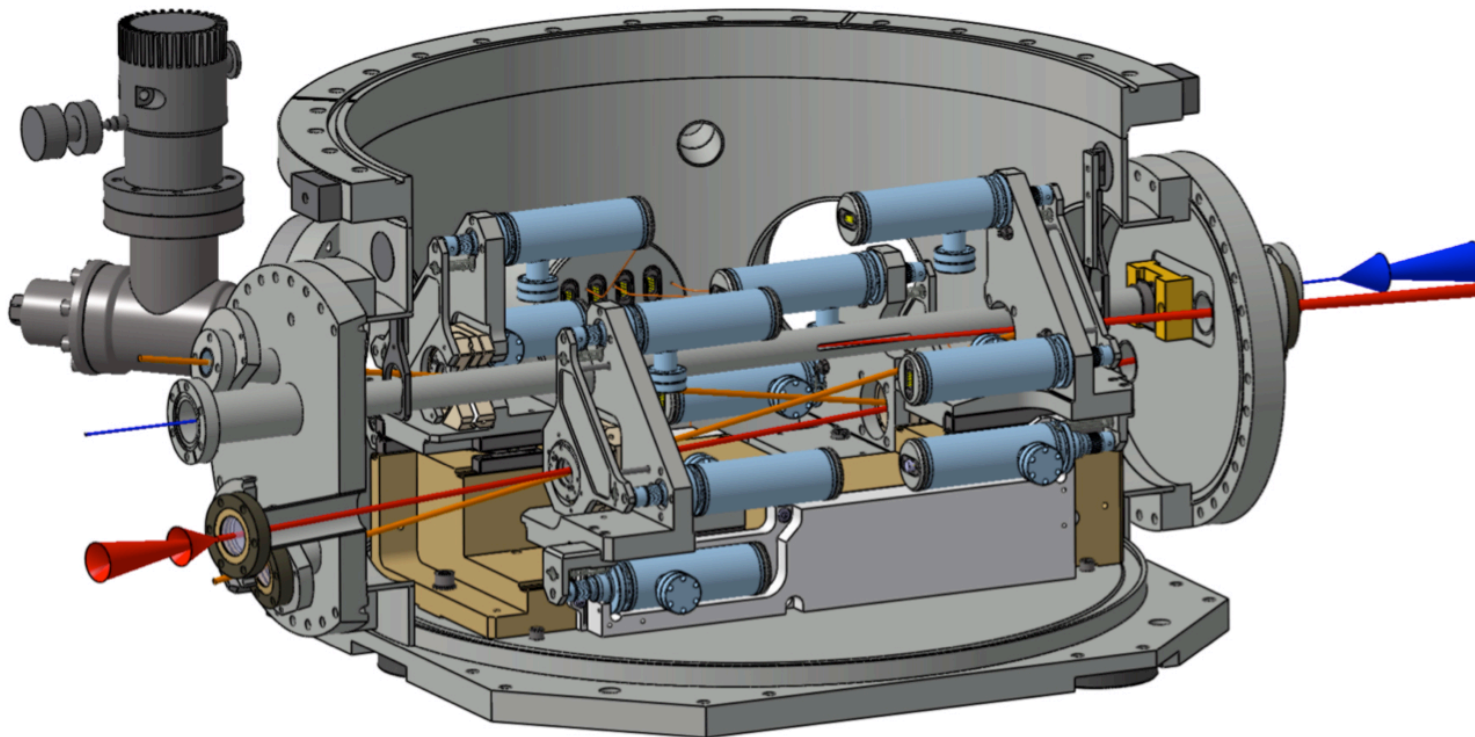

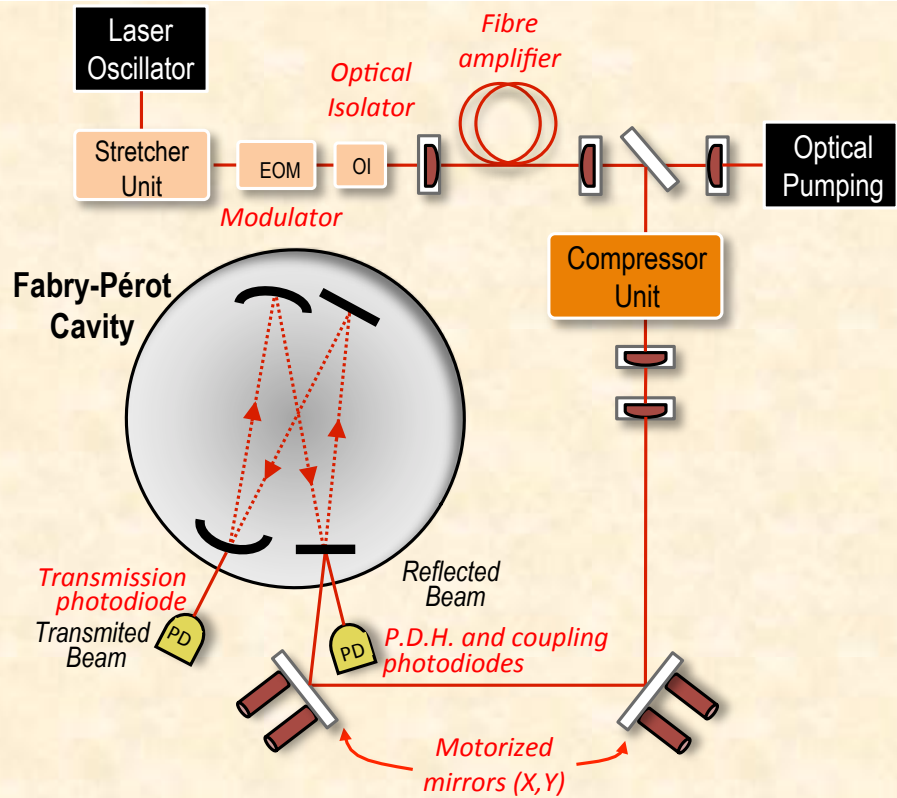

The laser

- Seed purchased commercially with low noise specifications.
- Repetition rate: 178.5 MHz
- Chirped pulse amplification
- Amplification in Yb doped fibre for better performances.
- Double stabilisation system:
 - laser on cavity
 - cavity on accelerator
 => low noise is critical for our operations.
- Design power: 50W (upgrade to higher power foreseen)
- So far we obtained only 10W at the ATF under data taking conditions.

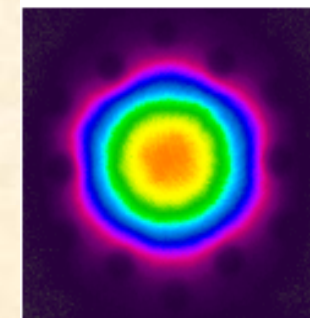
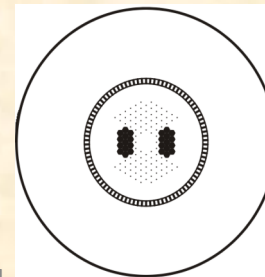
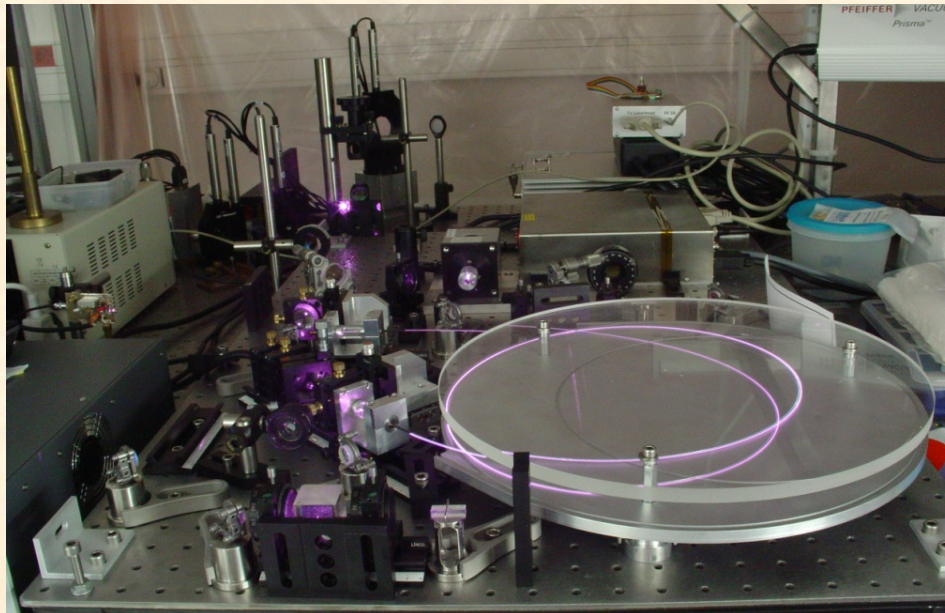

Laser amplification issues

- So far we have not yet reached our design performances.
- Several factors:
 - We experienced difficulties injecting the pump radiation in the core of the fibre
=> need pump with smaller numerical aperture
 - Heating of the fibre limits the power we can inject (we damaged several fibres)
=> improved cooling system
 - Our EO modulator has been damaged
=> need replacement.
 - Commercial laser failure (twice!)
=> being repaired
- We are currently working on an improved design to make operations more reliable.

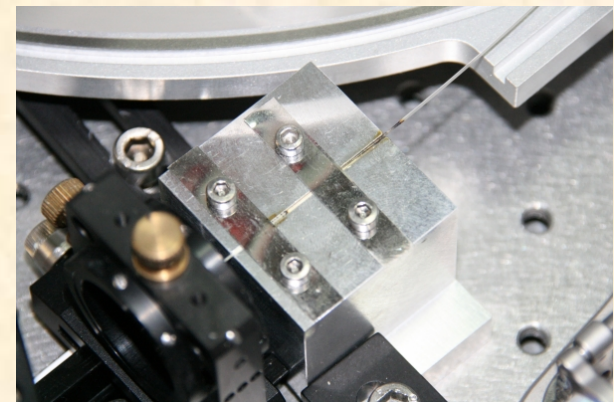

Digital feedback system

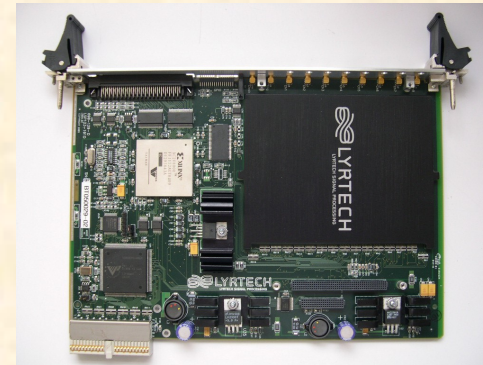
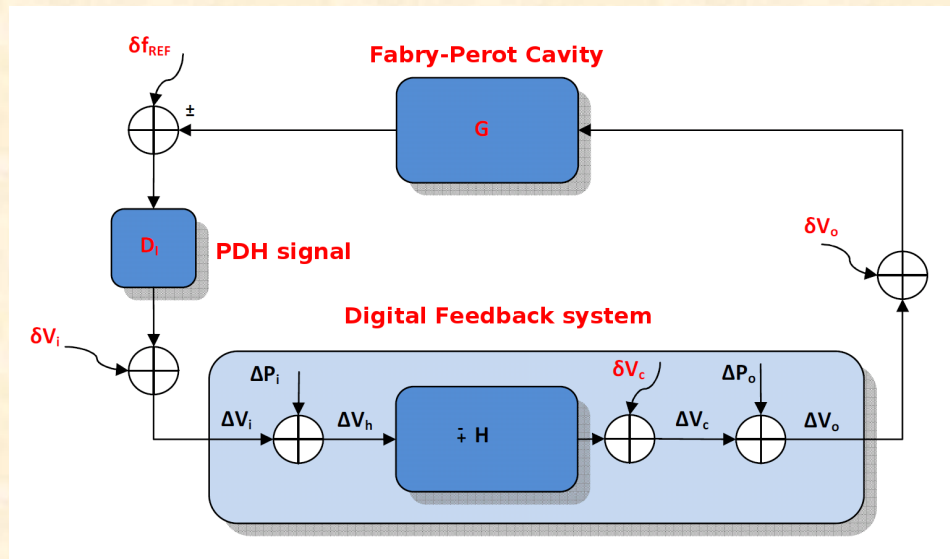

- To ensure that the laser pulses are properly stacked in the cavity we use a double digital feedback system.
- Such system gives us more flexibility than an analogue one.
- Based on a FPGA Virtex II board.
- The laser is locked on the cavity using the Pound Drever Hall technique.
- The cavity is locked on the ATF clock using a phase lock loop.

Cavity stabilisation: Pound Drever Hall technique

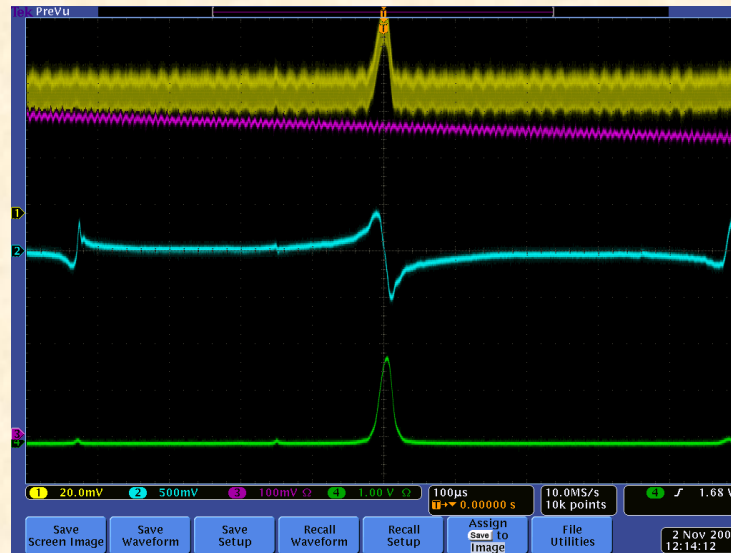

- We use the Pound Drever Hall technique to stabilise the cavity.
- The laser signal is modulated before being injected in the cavity.
- When close from the correct cavity length the signal “reflected” on the coupling port of the cavity is linearly proportional to the correction to be applied on the piezo actuator to adjust the laser cavity length.

Feedback resonances

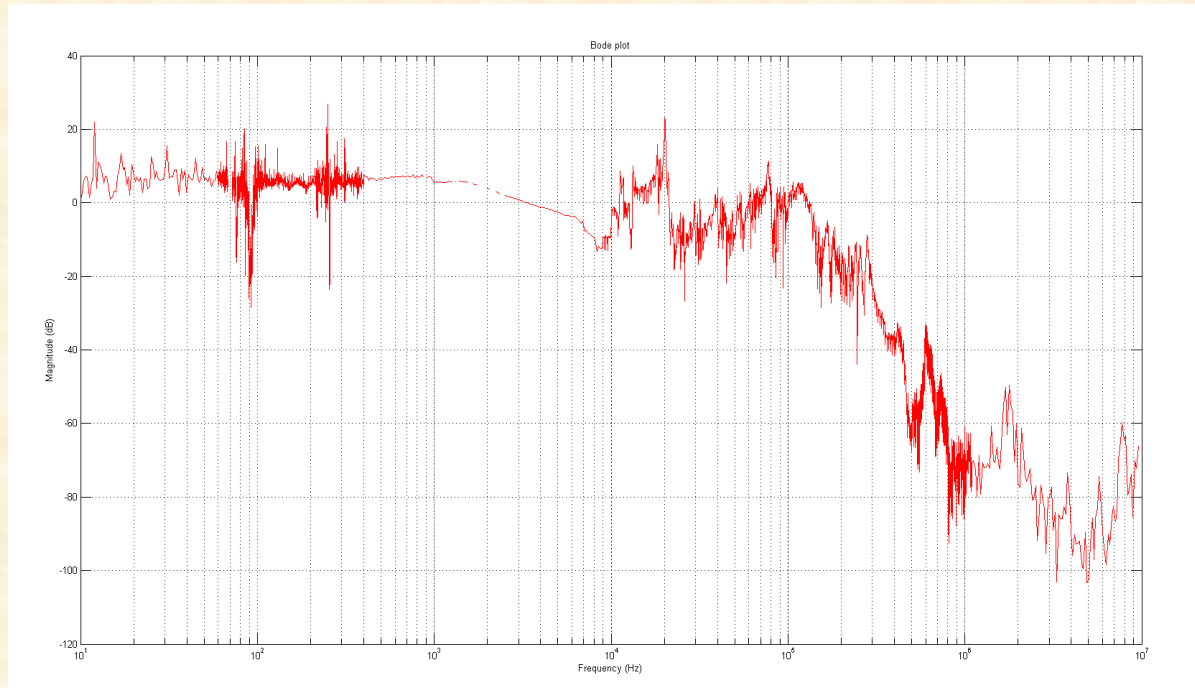

- To optimize the locking of the laser on the cavity, the transfer function of the system (cavity, piezo,...) must be measured.
- This allows to adjust the gain and the bandwidth of the feedback system to avoid resonances.

Improved gain

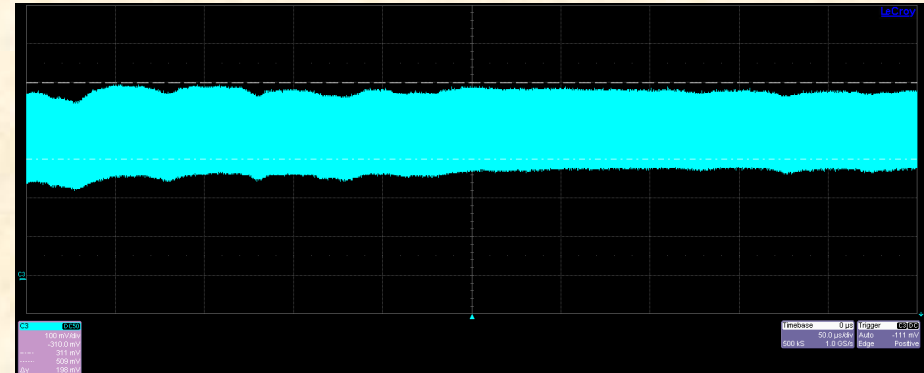
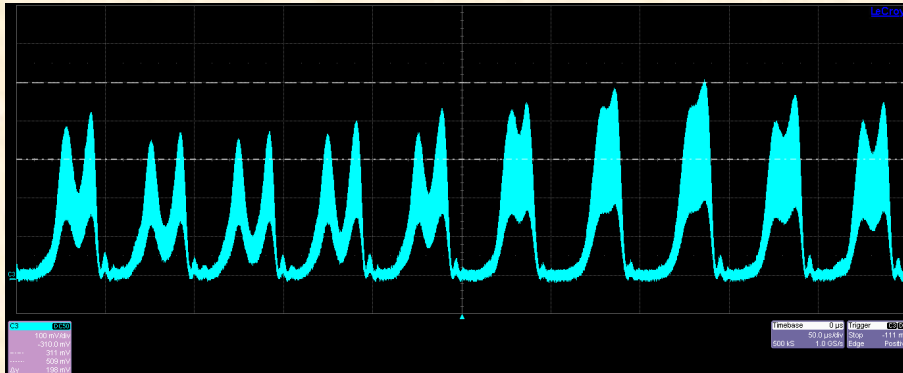

- Optimizing the filters in the feedback system can significantly improve the stability of the laser power stored in the cavity and therefore the flux of Compton produced.

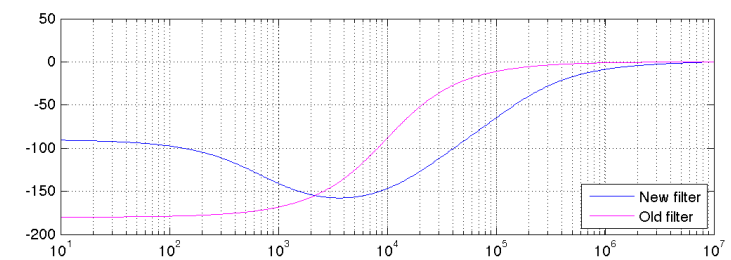
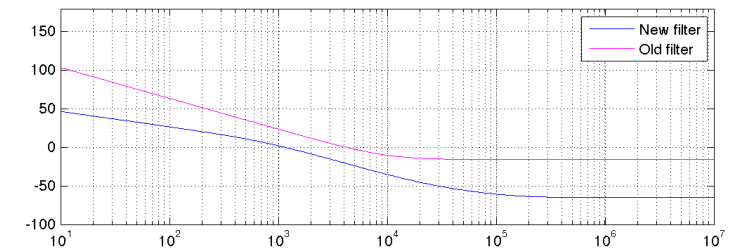

First data taking

- We achieved electron-laser collision during our first data taking shift and during each data taking run after.
- More about it in Iryna's talk.

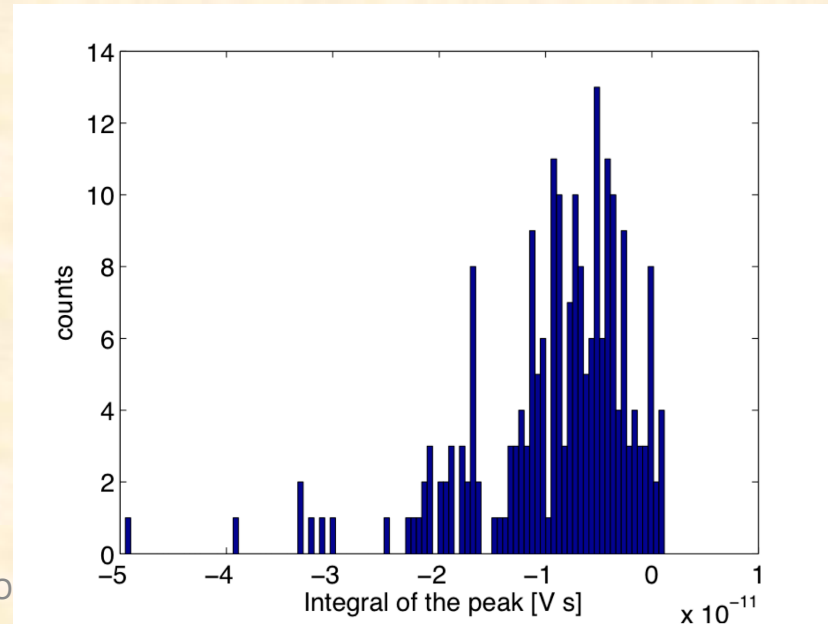
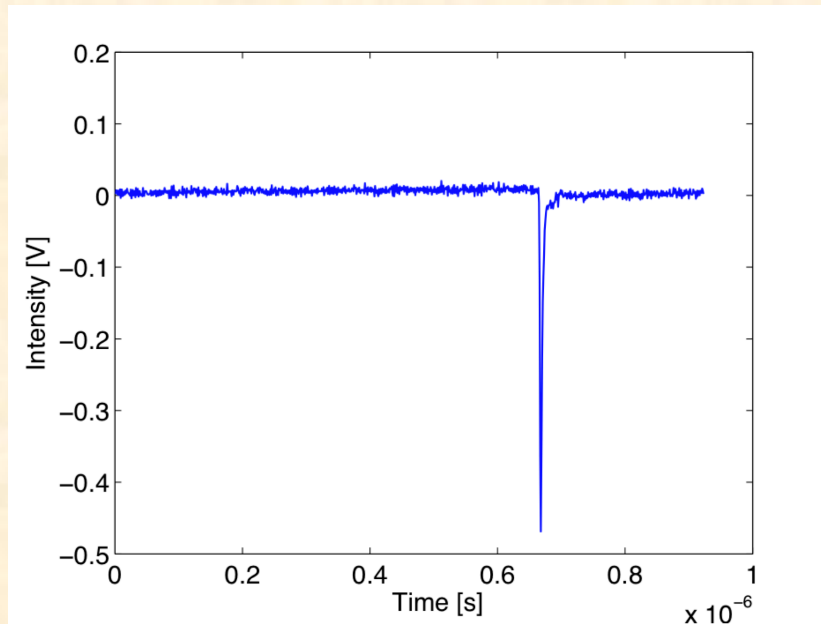
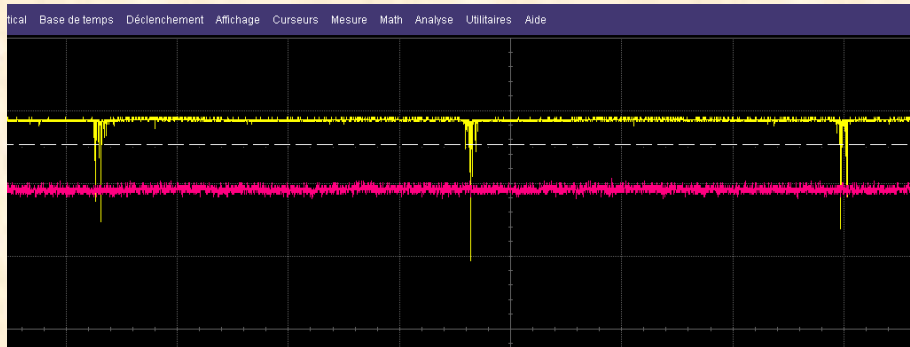

e-PO

Cavity stability & Power fluctuations

- During our data taking shifts at the end of 2010 we noticed significant fluctuations of the power stored in the cavity (blue trace) and consequently of the gamma ray yield (yellow trace).
- This issue was resolved in February by changing the filters in the digital feedback (but no Compton data have been taken with these filters yet).

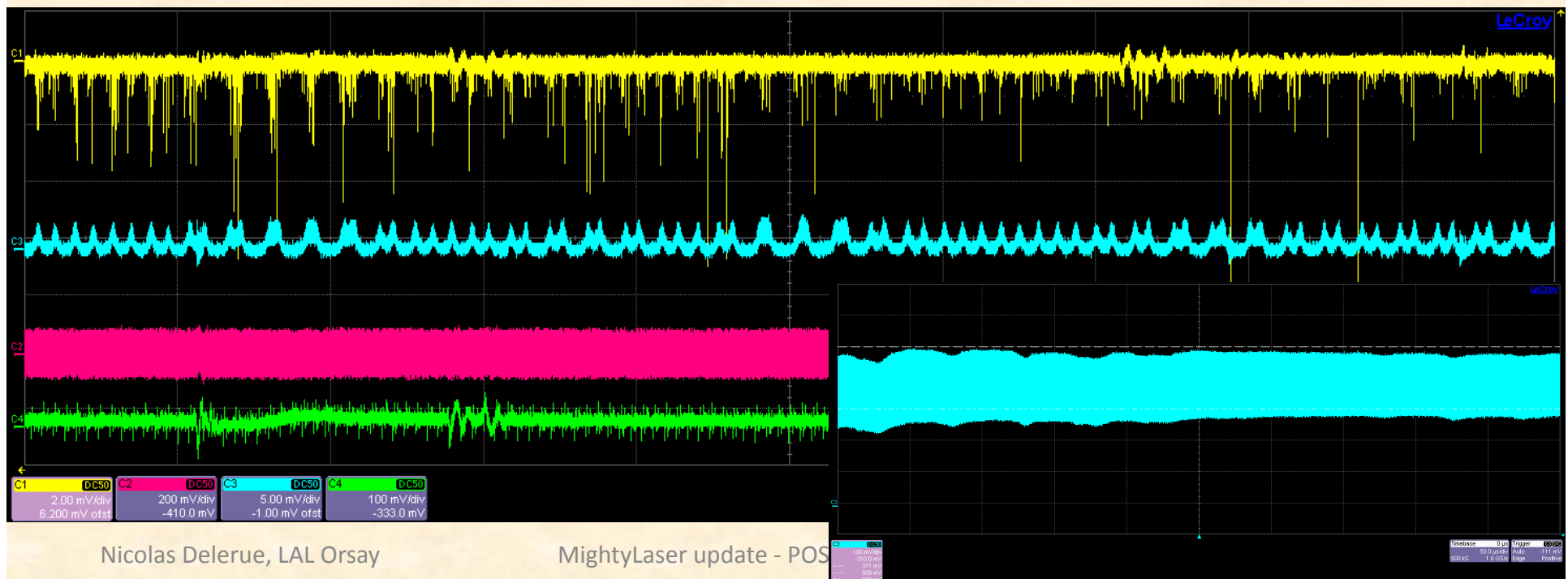

Current status

- In February we upgraded the laser to allow runs at higher power.
- We also improved the filters on the digital feedback system and we found a technique to improve the coupling efficiency.
- However our data taking run in February/March was postponed due to an incident on modulator 0 at the ATF.
- Our experiment suffered only minor damages during the earthquake, but our laser failed soon after.

High finesse locking

- In parallel to the work in Japan, we have a test cavity in Orsay.
- Recent improvements in our feedback and control system allowed us to lock reliably at a finesse of 30000.
- These improvements will soon be transposed to our KEK setup.

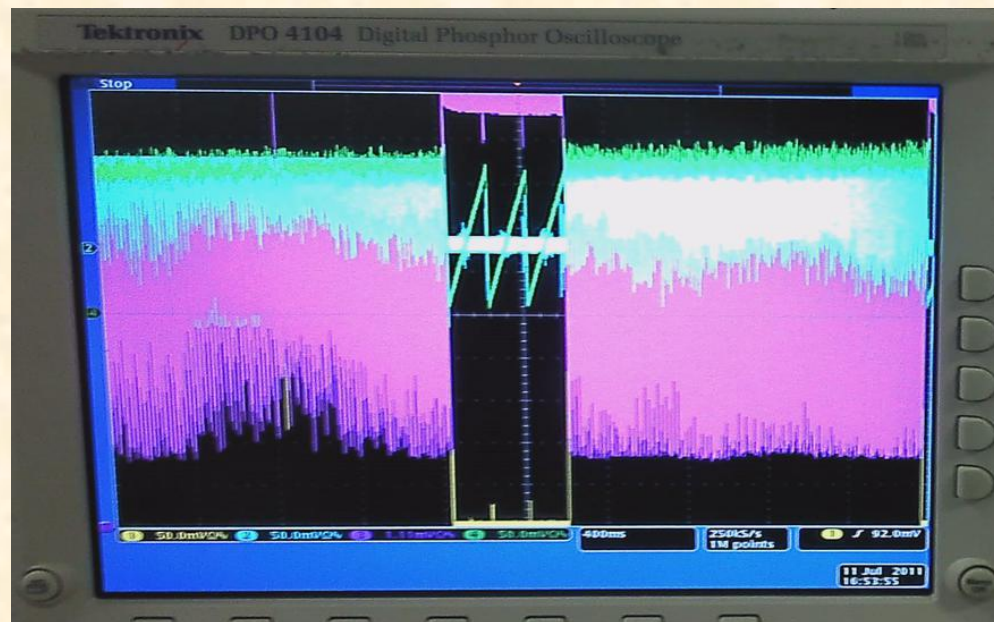

Future work

- We are planning to replace our data acquisition system with a faster one to be able to resolve individual bunches (separated by 5.6ns).
- A second piezo actuator has been added in the laser to give us a better control on the feedback.
- To increase the luminosity we intend to upgrade our mirrors to reach a finesse of 30000.
- We plan to upgrade our laser to reach 100W before injection (later 200W).
- Upgrade at the end of 2011 so our upgraded data run will be in early 2012.
- In the literature there is no record of a high power stored in a cavity for a long duration (several minutes) => significant effort will be required to achieve this.

Outlook

- We have used a high finesse cavity in an electron ring to produce polarised high energy gammas.
- We have not yet taken data at full laser power.
- We are working on improvements to the stability of our cavity.
- Recent progress have shown that we can stabilize the cavity even at higher finesse.
- No significant damages due to earthquake but data taking significantly delayed.
- During our next data taking run (early 2012?) we expect to increase our luminosity (instantaneous and integrated).