

Title		
Test_Board_2		
Size	Document Number	Rev
A	DUT	<RevCode>
Date:	Monday, July 01, 2019	Sheet 1 of 8

Test pins for PLL

FMC_SMA_DOUT+ << FMC_SMA_DOUT+

FMC_SMA_DOUT- << FMC_SMA_DOUT-

J25A

- A1
- A2
- A3
- A4
- A5
- A6
- A7
- A8
- A9
- A10
- A11
- A12
- A13
- A14
- A15
- A16
- A17
- A18
- A19
- A20
- A21
- A22
- A23
- A24
- A25
- A26
- A27
- A28
- A29
- A30
- A31
- A32
- A33
- A34
- A35
- A36
- A37
- A38
- A39
- A40

FMC400K

J25B

- B1
- B2
- B3
- B4
- B5
- B6
- B7
- B8
- B9
- B10
- B11
- B12
- B13
- B14
- B15
- B16
- B17
- B18
- B19
- B20
- B21
- B22
- B23
- B24
- B25
- B26
- B27
- B28
- B29
- B30
- B31
- B32
- B33
- B34
- B35
- B36
- B37
- B38
- B39
- B40

FMC400K

J25C

- C1
- C2
- C3
- C4
- C5
- C6
- C7
- C8
- C9
- C10
- C11
- C12
- C13
- C14
- C15
- C16
- C17
- C18
- C19
- C20
- C21
- C22
- C23
- C24
- C25
- C26
- C27
- C28
- C29
- C30
- C31
- C32
- C33
- C34
- C35
- C36
- C37
- C38
- C39
- C40

FMC400K

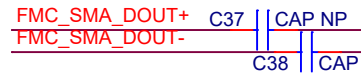

Title		
Test_Board_2		
Size	Document Number	Rev
A	FMC	<RevCode>
Date:	Monday, July 01, 2019	Sheet 2 of 8

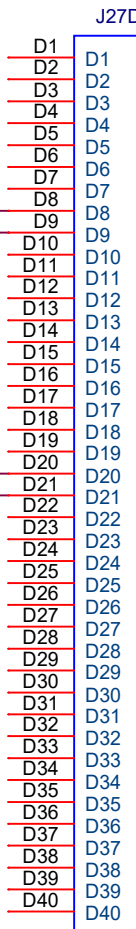
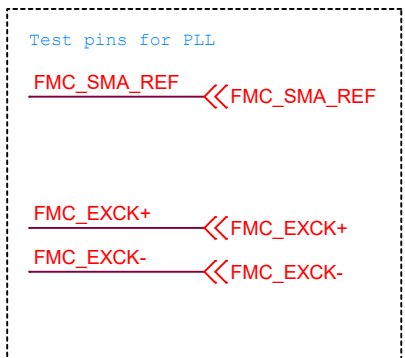

FMC400K

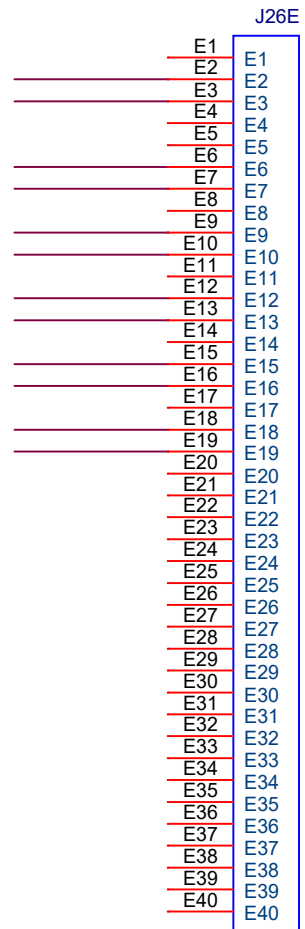

FMC400K

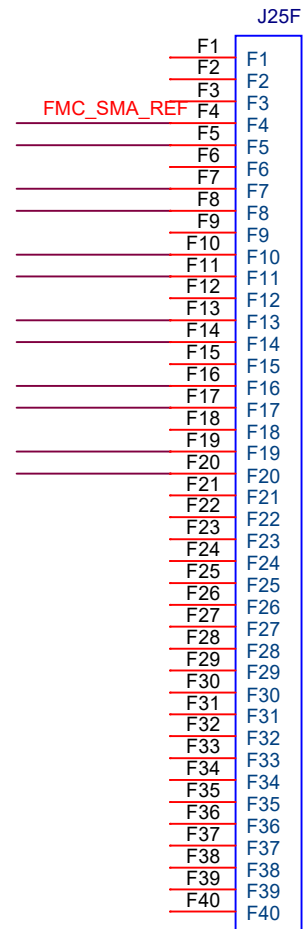

FMC400K

Title		
Test_Board_2		
Size	Document Number	Rev
A	FMC	<RevCode>
Date:	Monday, July 01, 2019	Sheet 3 of 8

J28G

- G1
- G2
- G3
- G4
- G5
- G6
- G7
- G8
- G9
- G10
- G11
- G12
- G13
- G14
- G15
- G16
- G17
- G18
- G19
- G20
- G21
- G22
- G23
- G24
- G25
- G26
- G27
- G28
- G29
- G30
- G31
- G32
- G33
- G34
- G35
- G36
- G37
- G38
- G39
- G40

FMC400K

J27H

- H1
- H2
- H3
- H4
- H5
- H6
- H7
- H8
- H9
- H10
- H11
- H12
- H13
- H14
- H15
- H16
- H17
- H18
- H19
- H20
- H21
- H22
- H23
- H24
- H25
- H26
- H27
- H28
- H29
- H30
- H31
- H32
- H33
- H34
- H35
- H36
- H37
- H38
- H39
- H40

FMC400K

J29I

- J1
- J2
- J3
- J4
- J5
- J6
- J7
- J8
- J9
- J10
- J11
- J12
- J13
- J14
- J15
- J16
- J17
- J18
- J19
- J20
- J21
- J22
- J23
- J24
- J25
- J26
- J27
- J28
- J29
- J30
- J31
- J32
- J33
- J34
- J35
- J36
- J37
- J38
- J39
- J40

FMC400K

J28J

- K1
- K2
- K3
- K4
- K5
- K6
- K7
- K8
- K9
- K10
- K11
- K12
- K13
- K14
- K15
- K16
- K17
- K18
- K19
- K20
- K21
- K22
- K23
- K24
- K25
- K26
- K27
- K28
- K29
- K30
- K31
- K32
- K33
- K34
- K35
- K36
- K37
- K38
- K39
- K40

FMC400K

Title		
Test_Board_2		
Size	Document Number	Rev
A	FMC	<RevCode>
Date:	Monday, July 01, 2019	Sheet 4 of 8

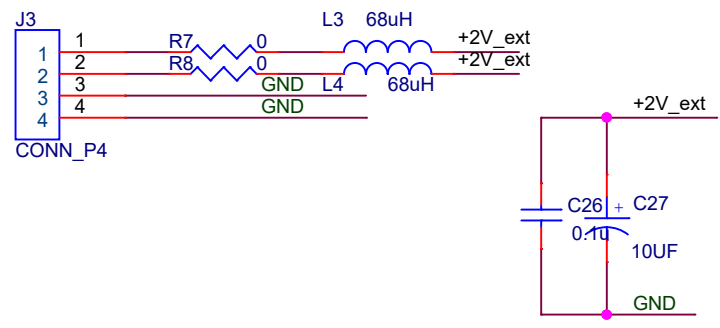
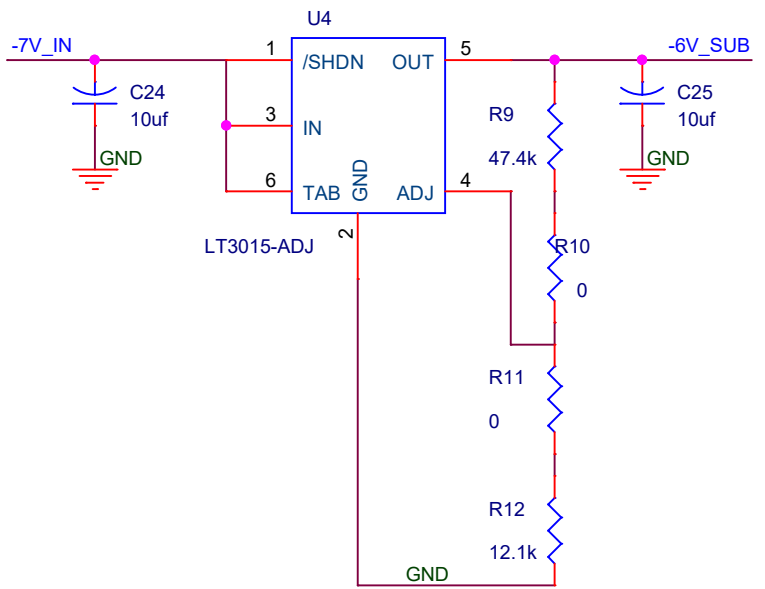
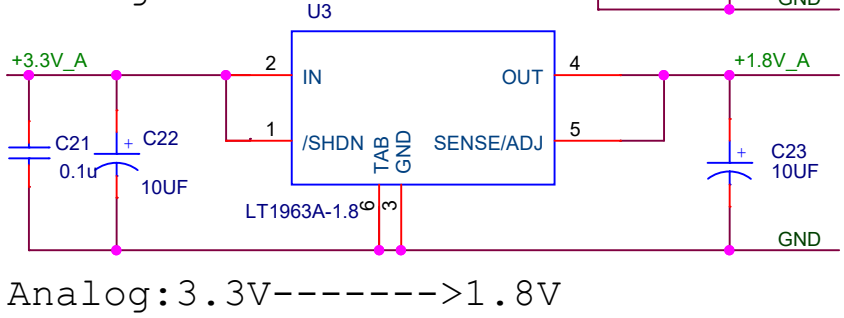
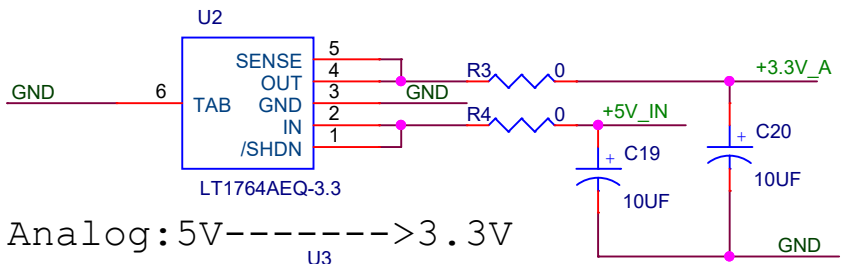
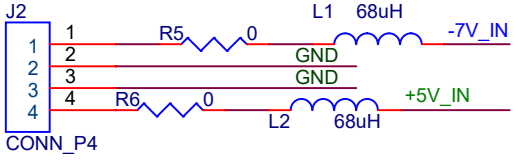
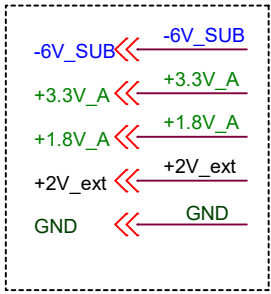

Title		
Test_Board_2		
Size	Document Number	Rev
A	LDO	<RevCode>
Date:	Monday, July 01, 2019	Sheet 5 of 8

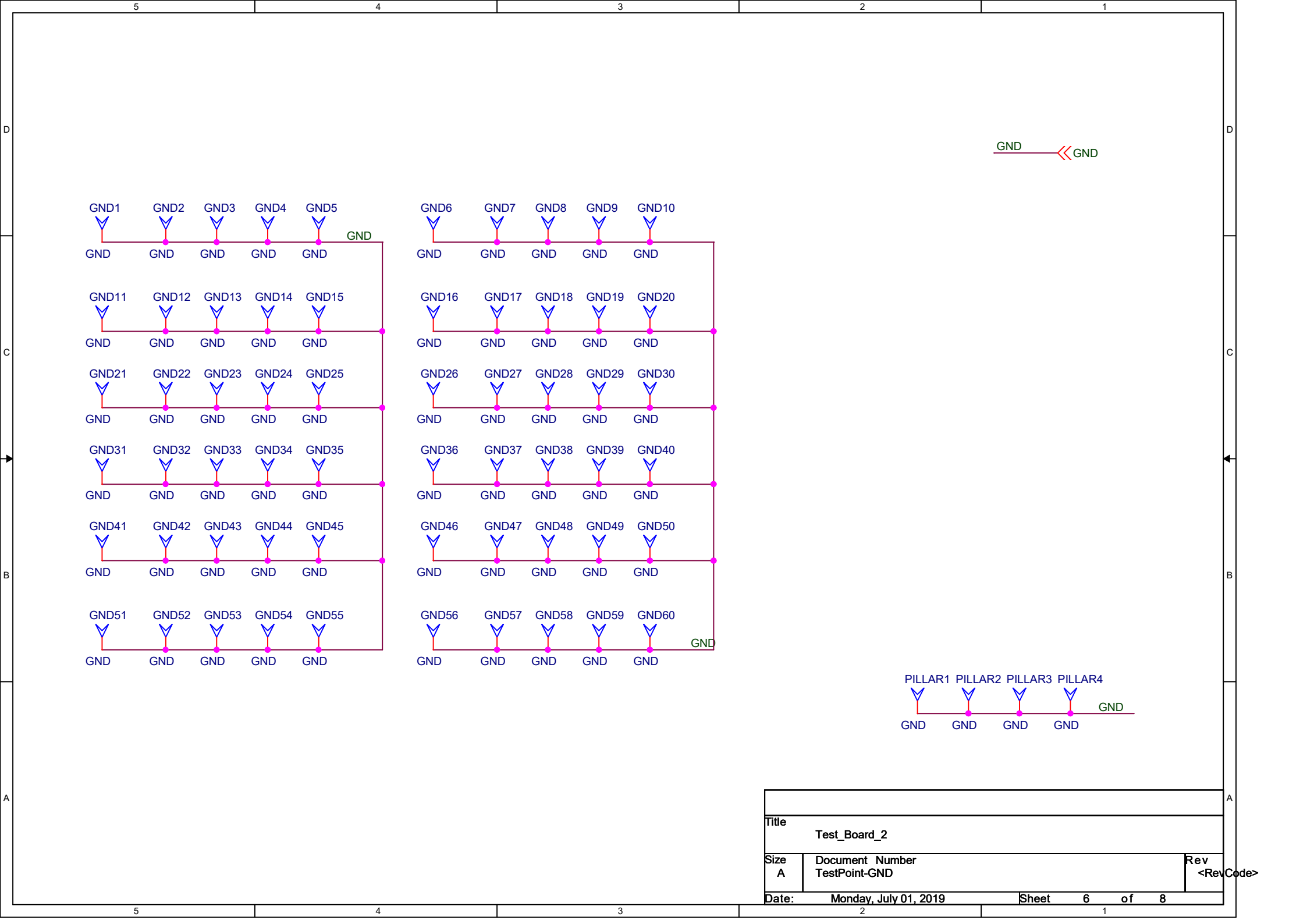

GND

PILLAR1 PILLAR2 PILLAR3 PILLAR4

 GND GND GND GND

Title		
Test_Board_2		
Size	Document Number	Rev
A	TestPoint-GND	<RevCode>
Date:	Monday, July 01, 2019	Sheet 6 of 8

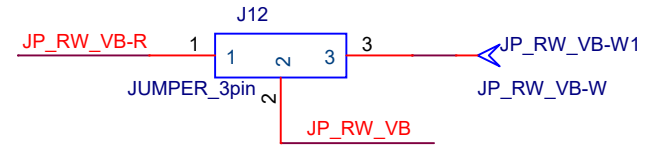
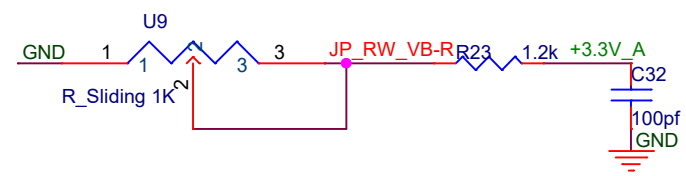
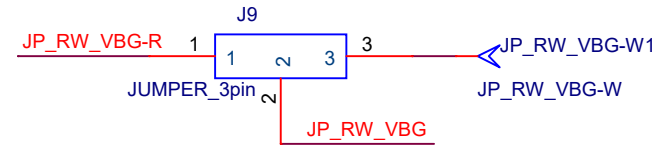
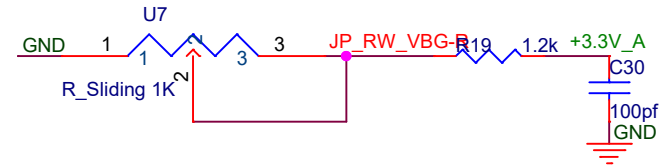
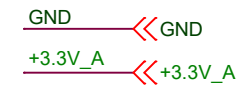
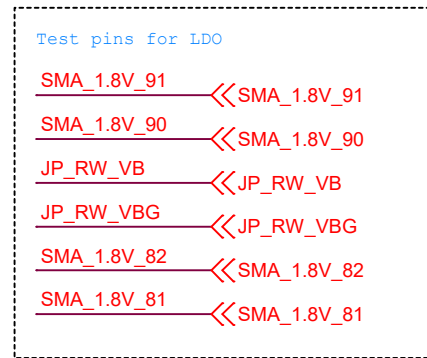
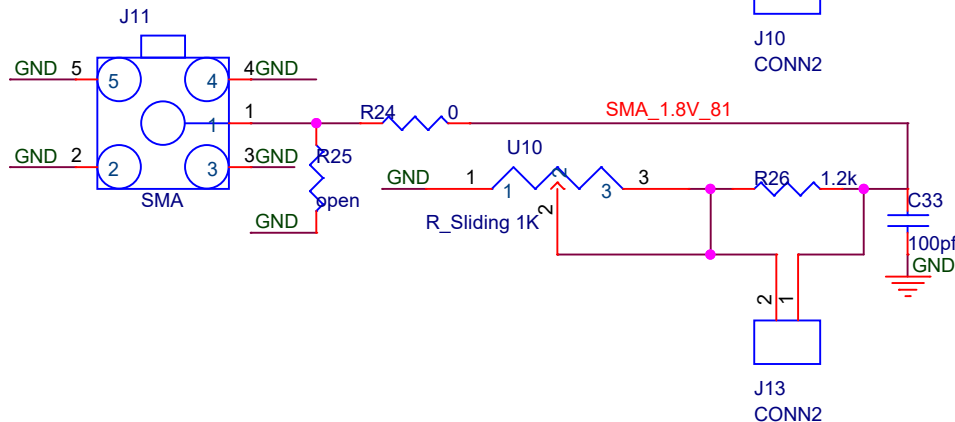
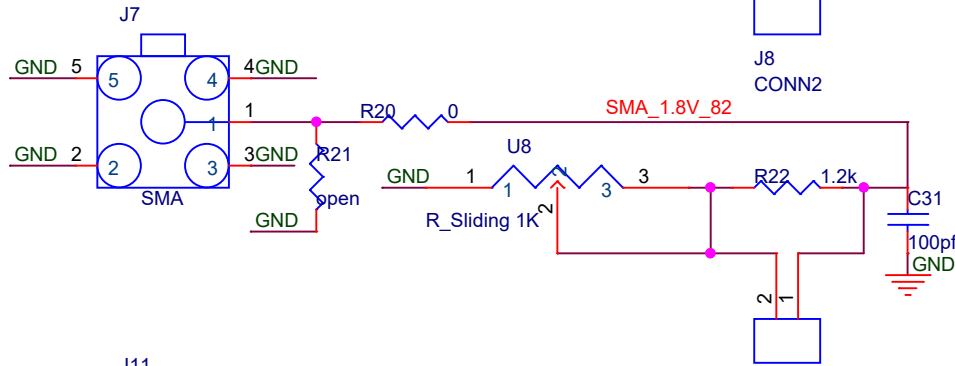
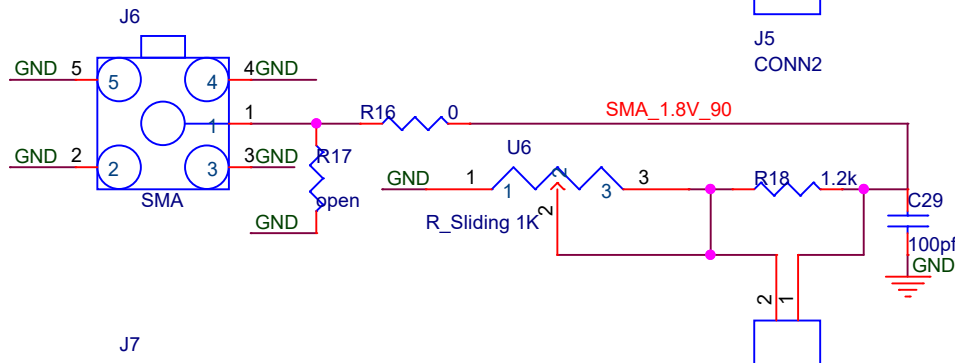
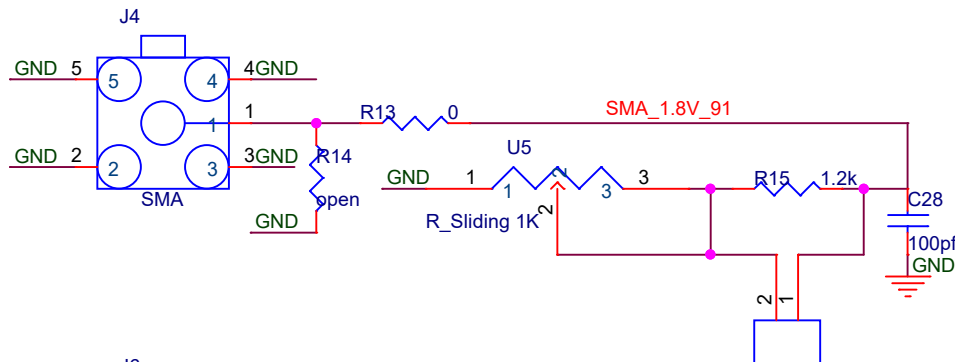

Title		
Test_Board_2		
Size	Document Number	Rev
A	TestPoint-LDO	<RevCode>
Date:	Monday, July 01, 2019	Sheet 7 of 8

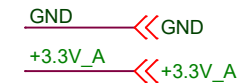
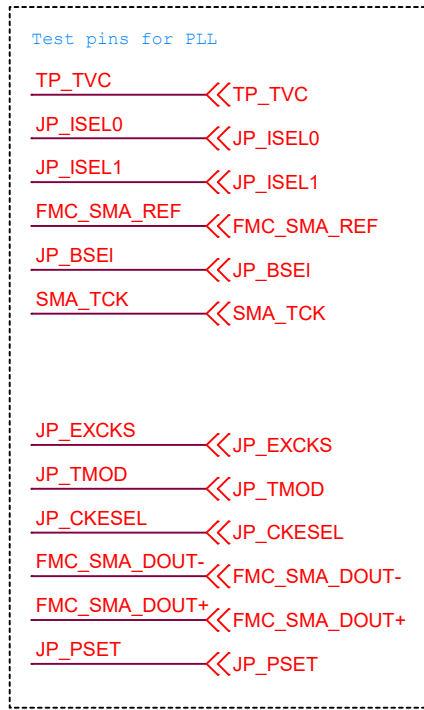
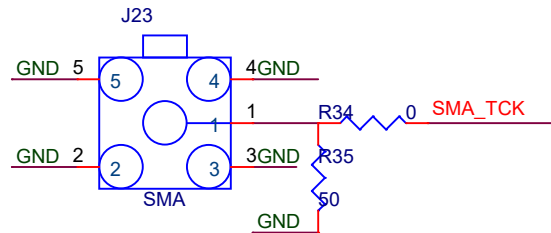
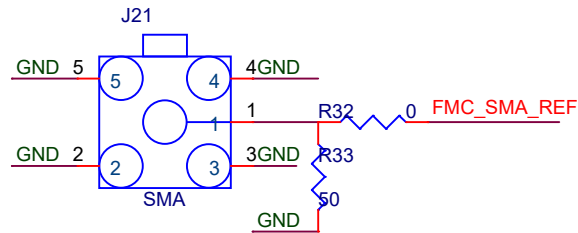
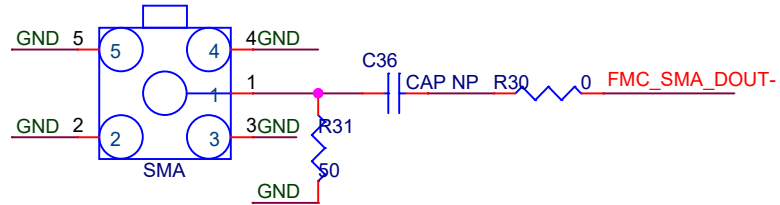
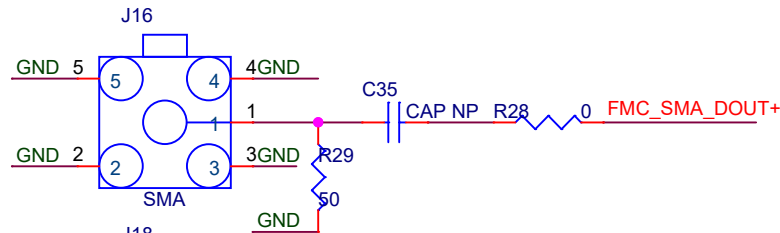
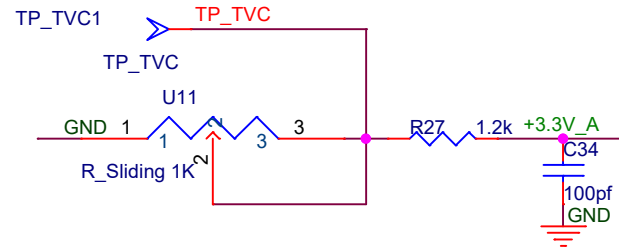
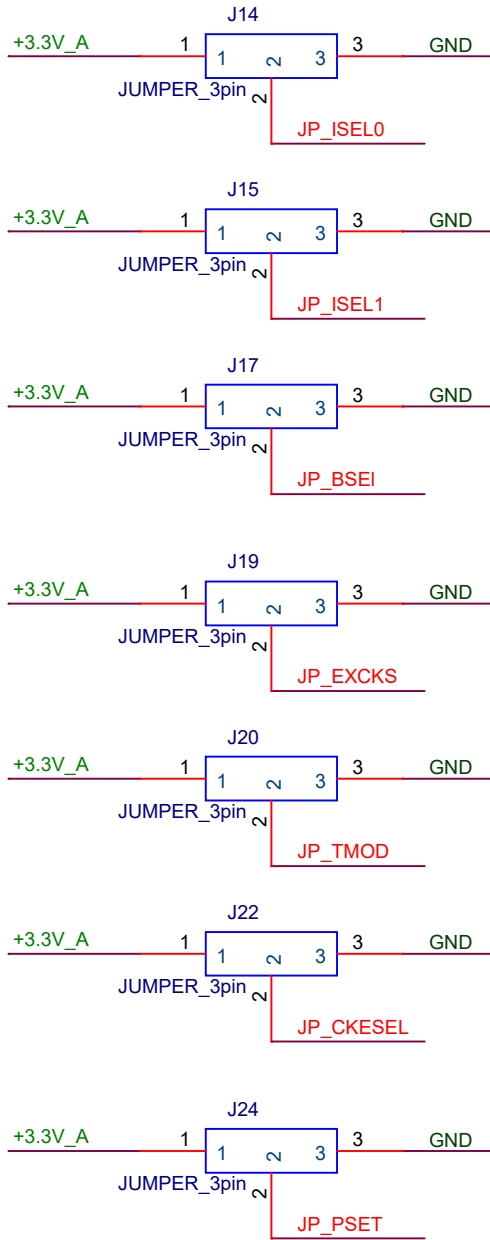

Title		
Test_Board_2		
Size	Document Number	Rev
A	TestPoint-PLL	<RevCode>
Date:	Monday, July 01, 2019	Sheet 8 of 8