

Design of an extruded aluminum vacuum chamber for narrow-gap undulator at the HEPS

Lei Zhang

2022-10-26

1. Introduction

The High Energy Photon Source (HEPS) is a 6 GeV, 200mA synchrotron radiation light. Its emittance is less than $40 \text{ pm}\cdot\text{rad}$, which can provide high brilliance hard X-rays to several tens of experimental stations. 14 beam lines will be built in the first stage of the project, and 4 IDs of them are in-air-undulators. An extruded aluminum vacuum chamber with 1-mm wall thickness has been designed for the 5 meters-long in-air-undulator.

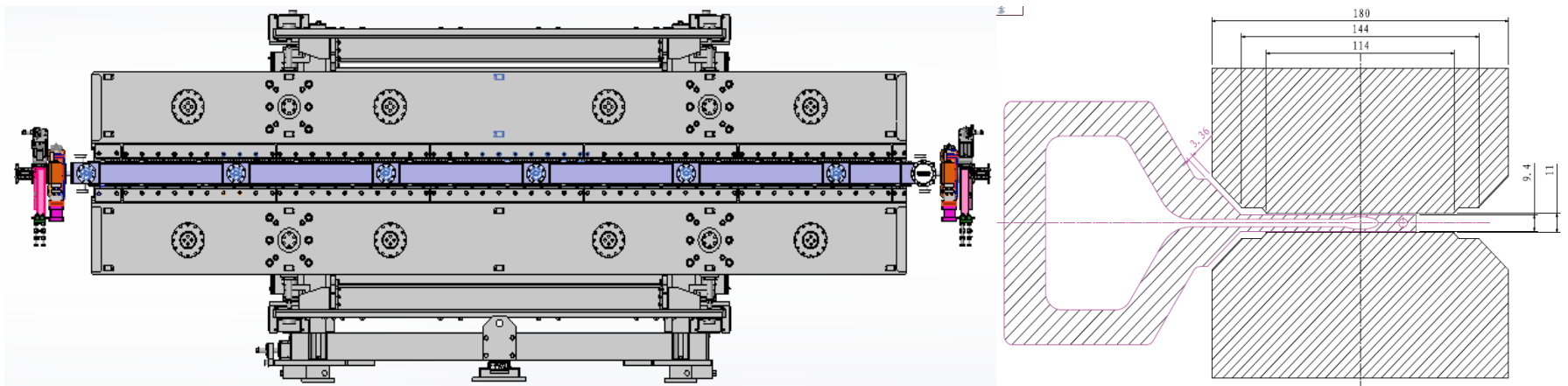
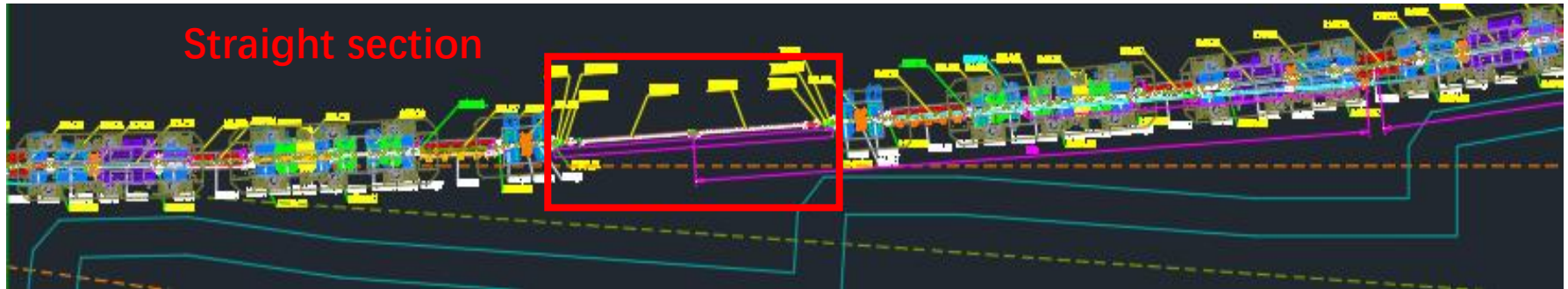

Fig.1 Introduction of the HEPS and IAU

2. Parameters

The parameters of the chamber

Tab.1 Parameters of the chamber

Parameter	Value
Length	5399 mm
Material	6063-T5 Aluminum
Vacuum degree (no beam)	5×10^{-10} Torr
Vacuum degree (with beam)	1×10^{-9} Torr
Working Gap	11mm
Wall thickness	1mm
Minimum thickness of chamber	9.4mm
Aperture size of ellipse	22mm×7.4mm
Chamber straightness	0.2mm

3. Simulation

3D model of the chamber. The extruded aluminum vacuum chamber will be installed in the 11mm-gap of the 5 meters-long in-air-undulator. And a absorber is installed downstream.

The vacuum simulation (Molflow+) of the chamber.

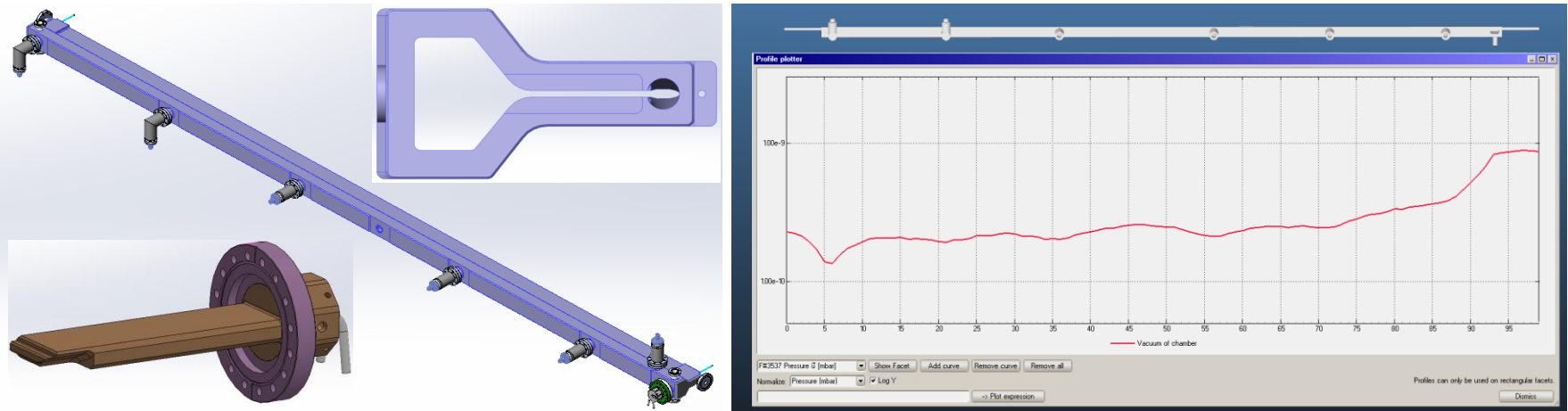

Fig.2 The 3D model and the simulated vacuum of the chamber

4. Prototype

The aluminum vacuum chamber will be installed in the gap of the IAU and needs to be aligned. Therefore, a good support and adjustment structure is needed.

First of all, the mold was refined several times and the aluminum alloy blank was extruded. Then, the blank was shaped. Last, vacuum chamber prototype is processed and welded.

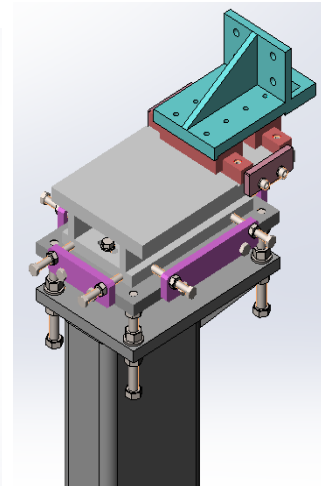
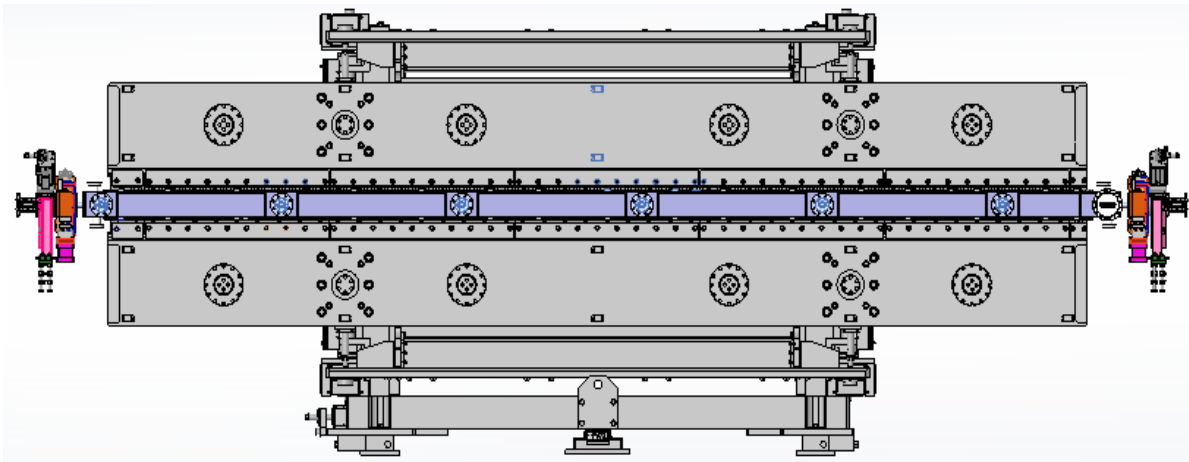

Fig.3 Introduction of the HEPS and IAU