

# 量子色动力学

---

中国科学院理论物理研究所

马建平

QCD Lectures

---

Perturbative Theory  
and Factorization

---

A version for 4 hours

---

## Versions:

2006: Notes, hand-writting on papers.

2007:

2008:

---

2017: Remade on Ipad.

2018: Improved

2023: simplified version for 4 hours,

## Contents:

1. QCD Lagrangian
  2. Divergences in QCD
  3. DIS and QCD Factorization
  4. TMD Factorization for SIDIS
  5. QCD Factorization for  $e^+e^- \rightarrow \text{hadron} + X$ .
- • • •

1.1

1. QCD Lagrangian:

$SU(3)$  gauge group, or  $SU(N_c)$

$$\mathcal{L}_{\text{QCD}} = -\frac{1}{2} \text{Tr} G^{\mu\nu} G_{\mu\nu} + \sum_{i=1}^{N_f} \bar{\psi}_i (i\gamma \cdot D - m_i) \psi_i,$$

$\psi_i(x)$ : quark field,

$G^{\mu\nu}(x)$ : gauge field,  $N_c \times N_c$  matrix,

$$G^{\mu\nu} = G^{a,\mu\nu} T^a, \quad a=1, \dots, N_c^2-1, \quad \text{Tr} T^a T^b = \frac{1}{2} \delta^{ab}.$$

$D^\mu = \partial^\mu + i g_s G^\mu$ , covariant derivative

$$G^{\mu\nu} = \partial^\mu G^\nu - \partial^\nu G^\mu + i g_s [G^\mu, G^\nu] = G^{a,\mu\nu} T^a,$$

$$G^{a,\mu\nu} = \partial^\mu G^{a,\nu} - \partial^\nu G^{a,\mu} - g_s f^{abc} G^{b,\mu} G^{c,\nu}$$

Gauge transformation:  $U(x)$ , element of  $SU(N_c)$ \*

$$\psi(x) \rightarrow U(x) \psi(x),$$

$$G^\mu(x) \rightarrow U(x) G^\mu(x) U^\dagger(x) - \frac{i}{g_s} U(x) \partial^\mu U^\dagger(x),$$

$\mathcal{L}_{\text{QCD}}$  is invariant under the transformation.

1.2.

quantization:

$$\mathcal{L}_{\text{eff}} = \mathcal{L}_{\text{QED}} + \mathcal{L}_{\text{GF}} + \mathcal{L}_{\text{FP}},$$

$\mathcal{L}_{\text{GF}}$ : gauge fixing term.

covariant gauge: 
$$\mathcal{L}_{\text{GF}} = -\frac{1}{2\xi} (\partial_\mu G^{a,\mu})^2,$$

$\mathcal{L}_{\text{FP}}$ : Faddeev - Popov term, ghost field.

$\Rightarrow$  Feynman rule, Feynman diagrams

$\xi = 1$ : Feynman gauge

other useful gauge: light cone gauge

$$n \cdot G = 0, \quad n^2 = 0 \text{ or } (\neq 0)$$

Physical gauge, no ghost needed.

1.3

Parameters in QCD:

$m_i$ : mass of quark.

$$m_u \sim m_d \sim O(1) \text{ MeV}, \quad m_s \sim 100 \text{ MeV}$$

$$m_c \sim 1.4 \text{ GeV}, \quad m_b \sim 5 \text{ GeV}, \quad m_t = 175 \text{ GeV}.$$

$g_s$ : coupling constant

Def: 
$$\alpha_s = \frac{g_s^2}{4\pi} = \alpha_s(\mu),$$

$\mu$ : renormalization scale

$$\mu^2 \frac{\partial \alpha_s(\mu)}{\partial \mu^2} = \beta(\alpha_s) = - (b_0 \alpha_s^2 + b_1 \alpha_s^3 + b_2 \alpha_s^4 + \dots),$$

$$b_0 = \frac{1}{4\pi} \left( 11 - \frac{2}{3} N_f \right), \quad b_1 = \frac{1}{8\pi^2} \left( 51 - \frac{19}{3} N_f \right),$$

$$b_2 = \frac{1}{128\pi^3} \left( 2857 - \frac{5033}{9} N_f + \frac{325}{27} N_f^2 \right),$$

$$\Rightarrow \beta < 0, \quad \mu^2 \rightarrow \infty, \quad \alpha_s(\mu) \rightarrow 0$$

Asymptotic freedom, (2014 诺贝尔奖)

1.4.

Perturbative theory :

U.V. divergences,  $d$ -dim. regularization,

$$\parallel \left( \frac{2}{\epsilon} - \delta + \ln 4\pi \right) \quad (\text{Buras, Bardin}).$$

$\overline{\text{MS}}$  schema of renormalization :

subtraction of these pole combinations.

$\theta$ -term.

Massless QCD: high energy scattering + light hadrons

$\Rightarrow$  We can neglect mass of light quarks and heavy quarks.

$$\Rightarrow \mathcal{L}_{\text{QCD}} = -\frac{1}{2} \text{Tr} G^{\mu\nu} G_{\mu\nu} + \sum_{\bar{q}} \bar{q} i \gamma \cdot D q$$

$\bar{q} = u, d, s$

Only one dimensionless parameter:  $g_s$  or  $\alpha_s$

energy scale.  $\Lambda_{\text{QCD}} \sim 100 \text{ MeV}$ .

2.1

## 2. Divergences in QCD

♥ Light-cone coordinate system:

A momentum  $P$  (or vector) in Cartesian coordinate system:  $P^\mu = (P^0, P^1, P^2, P^3)$ , metric  $g_{\mu\nu}$

In light-cone coordinate system:

$$P^\mu = (P^+, P^-, P^1, P^2), \quad P_\perp^\mu = (0, 0, P^1, P^2),$$

$$P^+ = \frac{1}{\sqrt{2}}(P^0 + P^3), \quad P^- = \frac{1}{\sqrt{2}}(P^0 - P^3).$$

Dot-product of two vectors:

$$A \cdot B = \underline{A^+ B^- + A^- B^+} - A^1 B^1 - A^2 B^2 - A^3 B^3.$$

metric  $g_{\mu\nu}$

Lorentz boost along the  $z$ -direction:

$$P^\mu \rightarrow P'^\mu, \quad p_1^+ = \alpha P^+, \quad p_1^- = \frac{1}{\alpha} P^-, \quad p_\perp'^\mu = p_\perp^\mu \quad *$$



2.2.

The advantage: Large momentum in the  $z$ -direction:

$$p^3 \rightarrow \infty,$$

$$P^\mu = (P^+, P^-, p_1^1, p_1^2) \approx (P^+, 0, 0, 0)$$

Two light-cone vectors:

$$l^\mu = (1, 0, 0, 0), \quad n^\mu = (0, 1, 0, 0), \quad l^2 = n^2 = 0$$

$$l \cdot n = 1, \quad g_{\perp}^{\mu\nu} = g^{\mu\nu} - n^\mu l^\nu - l^\mu n^\nu,$$

$$A_{\perp}^\mu = g_{\perp\mu\nu} A^\nu.$$

rapidity: 
$$y = \frac{1}{2} \ln \frac{p^+}{p^-} *$$

$$n \cdot A = A^+, \quad l \cdot A = A^-,$$

2.3.

Divergences in QCD:

U.V. divergences

Regularization + renormalization

Collinear divergences

I.R. divergences

Glauber divergences

??

Consider a massless quark in final state:

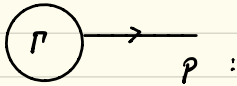
  $\bar{u}(p) \Gamma(p) \quad p^\mu = (p^+, 0, 0, 0)$

The quark can emit gluons.

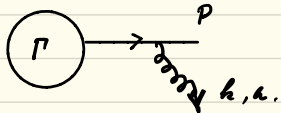
  $\bar{u}(p) (-i g_s \gamma^\mu \epsilon^\nu T^a) \frac{i \delta^-(p+k)}{(p+k)^2 + i\epsilon} \Gamma(p+k)$

Collinear divergence:  $k^\mu \sim (1, \lambda^2, \lambda, \lambda)$ ,  $\lambda \rightarrow 0$

$$\frac{i \delta^-(p+k)}{(p+k)^2 + i\epsilon} = \frac{i \delta^-(p+k)^\dagger}{2p^+ k^- + i\epsilon} (1 + O(\lambda)) \sim \frac{1}{\lambda^2}, \text{ divergent!}$$

2.4.

I.R. divergence:  $k^\mu \sim (\lambda, \lambda, \lambda, \lambda)$ , soft gluon

$$\frac{i \delta \cdot (p+k)}{(p+k)^2 + i\epsilon} = \frac{i \delta \cdot p^+}{2p^+ k^- + i\epsilon} (1 + O(\lambda)) \sim \frac{1}{\lambda}, \text{ divergent!}$$

In QED: such divergences are "eliminated" with physical requirements.

in QCD: We have no quarks and gluons as observable states. ??

A loop-example: quark form factor

Tree-level:

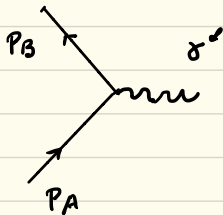

$$P_A^\mu = (P_A^+, 0, 0, 0),$$

$$\bar{V}(P_B) \delta^\mu u(P_A), \quad P_B^\mu = (0, P_B^-, 0, 0).$$

Corrections from high orders of  $\alpha_s$ .

$$\delta \cdot P_A u(P_A) = \delta^- P_A^+ u(P_A) = 0, \quad \bar{V}(P_B) \delta \cdot P_B = \bar{V}(P_B) \delta^+ P_B^- = 0$$

2.5

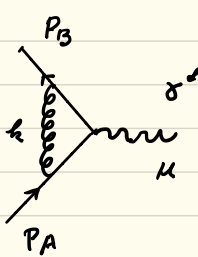

$$\Gamma = \bar{v}(p_B) \int \frac{d^4 k}{(2\pi)^4} (-i g_s \delta_\rho T^a) \frac{i \delta \cdot (p_B - k)}{(p_B + k)^2 + i\epsilon}$$

$$\cdot g_\mu \frac{i \delta \cdot (p_A - k)}{(p_A - k)^2 + i\epsilon} (-i g_s \delta^\rho T^a) u(p_A)$$

$$\cdot \frac{-i}{k^2 + i\epsilon}, \quad \left\{ \begin{array}{l} \delta_\rho \otimes \gamma^\rho \sim \delta^- \otimes \delta^+ \\ + \delta_\perp \otimes \delta_\perp \end{array} \right.$$

Collinear to A;  $k^\mu \sim (1, \lambda^2, \lambda, \lambda)$ ,  $\lambda \ll 1$

Expand the integrand in  $\lambda$ , the leading order:

$$\Gamma_A = \int \frac{d^4 k}{(2\pi)^4} \frac{-i}{k^2 + i\epsilon} \bar{v}(p_B) \left( \frac{-g_s \not{p}_\rho T^a}{k^2 + i\epsilon} \right) g_\mu \frac{i \delta \cdot (p_A - k)}{(p_A - k)^2 + i\epsilon}$$

$$\cdot (-i g_s \delta^\rho T^a) u(p_A)$$

$$\sim \int \frac{d^4 k}{(2\pi)^4} \cdot \mathcal{O}\left(\frac{1}{\lambda^4}\right), \quad \begin{array}{l} k^2 \sim \lambda^2, \\ (p_A - k)^2 \sim \lambda^2 \end{array}$$

divergent !!

$$d^4 k \sim \lambda^4$$

Power counting

2.6.

Collinear to B:  $k^\mu \sim (\lambda^2, 1, \lambda, \lambda)$

$$\Rightarrow \Gamma_B = \int \frac{d^4 k}{(2\pi)^4} \frac{-i}{k^2 + i\varepsilon} \bar{v}(p_B) (-i \gamma_5 \not{\partial} T^a) \frac{i \not{\partial} \cdot (-p_B - k)}{(p_B + k)^2 + i\varepsilon} \gamma^\mu \left( \frac{-\gamma_5 \not{p} T^a}{k^- - i\varepsilon} \right) u(p_A),$$

divergent!

I. R. divergence:  $k^\mu \sim (\lambda_s, \lambda_s, \lambda_s, \lambda_s)$  ⊙  $\lambda_s, \lambda_s$ .

$$\Gamma_s = \int \frac{d^4 k}{(2\pi)^4} \frac{-i}{k^2 + i\varepsilon} \frac{1}{k^+ + i\varepsilon} \frac{1}{k^- - i\varepsilon} \bar{v}(p_B) (-\gamma_5 \not{p} T^a) \gamma^\mu (-\gamma_5 \not{p} T^a) u(p_A),$$

divergent.

Subtraction:

$$\Gamma = \underbrace{(\Gamma - \Gamma_A - \Gamma_B + \Gamma_s)}_{\text{free from collinear- and I.R. divergences !!}} + (\Gamma_A + \Gamma_B - \Gamma_s)$$

⚡  $\Gamma_A, \Gamma_B$  also have I.R.!!  
(-)

But: light-cone singularity ...

2.7

Glauber - gluon:  $k^\mu \sim (\lambda^2, \lambda^2, \lambda, \lambda)$

$$\Gamma_G = \int \frac{d^4 k}{(2\pi)^4} \frac{-i}{-k^2 + i\varepsilon} \frac{1}{k^+ + i\varepsilon} \frac{1}{k^- - i\varepsilon} \bar{v}(p_B) (-g_s \gamma_\rho T^a) \gamma^\mu (-g_s \ell^\rho T^a) u(p_A),$$

it gives a divergent absorptive part, it is similar to Coulomb singularity.

⇒ Perturbation theory of QCD contains

I.R. singularity and collinear singularity !!

Perturbation theory of QCD is meaningless ??

There are no S-matrix elements with quarks or gluons as physical states. Unlike QED!

But

2.8

KCN theorem: (Kinoshita, Lee, N

state  $a, b$ ;  $a \rightarrow b$

The probability:  $|S_{ba}|^2 = |\langle b | S | a \rangle|^2$ .

In general, it contains divergences from degenerate states of  $|a\rangle$  and  $|b\rangle$ , like I.R.- and collinear divergences. Suppose: these divergences are regularized by a set of parameters  $[\mu]$ , e.g., quark mass ...  
 $\mu \rightarrow 0$ , divergences appear.

If we sum those energy degenerate states of  $|a\rangle$  or  $|b\rangle$ , then the sum:

$\sum_{D[a]} \sum_{D[b]} |S_{ba}|^2$  is free from these  
divergences!!

Note:  $a$  and  $b$  do not have the same energy, or in the same state.

2. P.

R-value  
↓

For  $e^+e^- \rightarrow$  hadrons, special case of KLN,

because of that hadrons or QCD states only appear in final state. Bloch-Nordsieck theorem.

OPE:

$$J^\mu(x) J^\nu(0) = C_0^{\mu\nu}(x) I + C_1^{\mu\nu}(x) : \bar{\psi} \psi :$$

+ ...

We have only take the leading order here.

The remaining terms are power-suppressed

$$\sim 1/s$$

SVZ - sum-rule.

R-ratio

Renormalon  $\Rightarrow$  power correction at  $1/s$ .





3.1.

### 3. DIS and QCD Factorization

!!

DIS: Deeply Inelastic Scattering

A classical example of QCD applications

DIS: (unpolarized case)

$$e(k) + h(P) \rightarrow e(k') + X,$$

$h$ : hadron, usually it is a proton.

At leading order of QED:

$$q = k - k',$$

$$q^2 = (k - k')^2 = -Q^2 < 0,$$

$$y = \frac{q \cdot P}{k \cdot P},$$

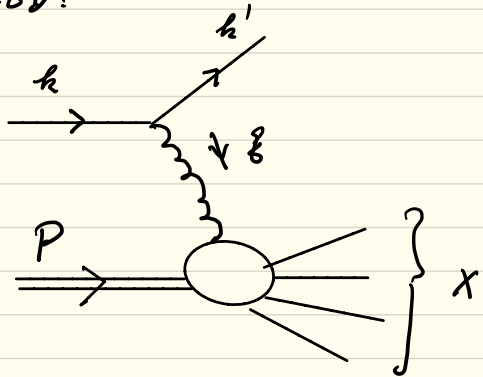

$$X_B = \frac{Q^2}{2q \cdot P}, \quad \text{Bjorken variable}$$

3.2.

The cross-section:

$$k' \cdot \frac{d\sigma}{d^3k'} = \frac{2}{k \cdot p} \left( \frac{\alpha^2}{g^2} \right)^2 L_{\mu\nu} W^{\mu\nu},$$

$$L^{\mu\nu} = k'^{\mu} k^{\nu} + k^{\mu} k'^{\nu} - k \cdot k' g^{\mu\nu}, \quad \text{the leptonic tensor}$$

The hadronic tensor:

$$W^{\mu\nu} = \frac{1}{4\pi} \int d^4x e^{i g \cdot x} \sum_X \langle h(P) | J^{\mu}(x) | X \rangle \langle X | J^{\nu}(0) | h(P) \rangle,$$

$$J^{\mu} = Q_f \bar{\psi} \gamma^{\mu} \psi, \quad (\text{take } Q_f = 1 \text{ for brevity}).$$

The decomposition:

$$W^{\mu\nu}(p, g) = \left( -g^{\mu\nu} + \frac{g^{\mu} g^{\nu}}{g^2} \right) F_1(x, Q^2) + \frac{\hat{p}^{\mu} \hat{p}^{\nu}}{p \cdot g} F_2(x, Q^2),$$

$$g_{\mu} W^{\mu\nu} = g_{\nu} W^{\mu\nu} = 0$$

$$\hat{p}^{\mu} = p^{\mu} - \frac{g \cdot p}{g^2} g^{\mu},$$

em-gauge invariance.

$$x = x_B.$$

Need to know  $F_1, F_2$  !!

3.3.

Kinematical region of DIS: Bjorken limit

$$Q^2 \rightarrow \infty, \quad 28 \cdot P \rightarrow \infty, \quad x_B = \frac{Q^2}{28 \cdot P} \quad \text{fixed}$$

$$0 < x_B < 1.$$

Bjorken scaling:  $F_{1,2}(x, Q^2) \approx F_{1,2}(x), \quad Q^2 \rightarrow \infty,$

Pre-QCD:

(Naive) parton model:

$$\bar{F}_2(x, Q^2) = x f_p(x), \quad 2x F_1(x, Q^2) = \bar{F}_2(x, Q^2)$$

Automatical scaling. "P" for parton,

The initial hadron  $h(P)$  consists of many partons.

$f_p(x)$ : the probability to find a parton  
with the momentum  $xP$ ,  $x$  %.

DIS:

$$\gamma^e(\ell) + P(xP) \rightarrow P + X.$$

3.4

With QCD: Improved parton model

QCD factorization theorem for DIS:

$$\begin{aligned} F_2(x, Q^2) &= x \sum_a \int_x^1 \frac{d\xi}{\xi} C_a\left(\frac{x}{\xi}, Q^2, \mu^2\right) f_{q/h}(\xi, \mu^2) + \dots \\ &= x \sum_a C_a \otimes f_{q/h} \left(1 + O\left(\frac{\Lambda^2}{Q^2}\right)\right), \end{aligned}$$

$$a = g, \bar{g}, q,$$

$f_{q/h}(\xi, \mu^2)$ : parton distribution function (PDF).

defined with QCD operators,  $\xi$ : %.

It is a distribution, not a probability. (!)

$C_a\left(\frac{x}{\xi}, Q^2, \mu^2\right)$ : perturbative coefficient function,  
free from collinear- and I.R. divergences.

At leading order:  $C_g(z, Q^2, \mu^2) = \delta(1-z) + O(\alpha_s)$ ,

it reproduces the (naive) parton model,

and "Partons" = quarks,  $\bar{g}$ .

3.5.

**Question:** We don't know the inner-structure of hadrons, how we make predictions?

Traditional way: Operator Product Expansion (OPE).

Modern way to discuss DIS: (Diagram expansion)

Breit frame for Bjorken limit:

$h$ : moving in the  $z$ -direction:  $P^\mu = (P^+, \frac{m_h^2}{2P^+}, 0, 0)$ ,

$g$ : moving in the  $-z$ -direction:  $g^\mu = (g^+, g^-, 0, 0)$

$$g^+ < 0.$$

Bjorken limit is realized  $g^- > 0$

$$\text{by } g^- \rightarrow \infty, \Rightarrow Q^2 = -2g^+g^- \rightarrow \infty,$$

$$2P \cdot g = 2P^+g^- + 2P^-g^+ \rightarrow \infty$$

$$x = \frac{Q^2}{2P \cdot g} = -\frac{g^+}{P^+}, \text{ fixed.}$$

If  $P^+$  is large,  $P^\mu \approx (P^+, 0, 0, 0)$ .

3.6

To derive the factorization:

$$\text{Def: } T^{\mu\nu}(\mathcal{B}, P) = \frac{1}{4\pi} \int d^4x e^{i\mathcal{B}\cdot x} \langle P | T(J^\mu(x) J^\nu(0)) | P \rangle,$$

$$\Rightarrow W^{\mu\nu}(\mathcal{B}, P) = 2 \text{Im} T^{\mu\nu}(\mathcal{B}, P).$$

We know: A hadron consists of partons.

partons:  $\mathcal{B}, \bar{\mathcal{B}}, G$ .

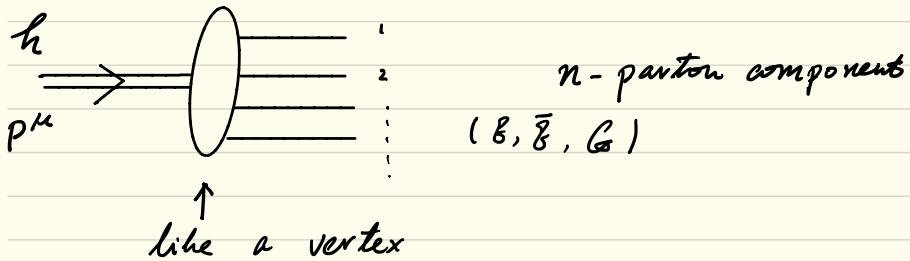

Suppose: We know these vertices, and use perturbative theory of QCD to calculate  $T^{\mu\nu}$ ,

$T^{\mu\nu}$  is a Green's function,

3.7.

A 4-point Green's function:

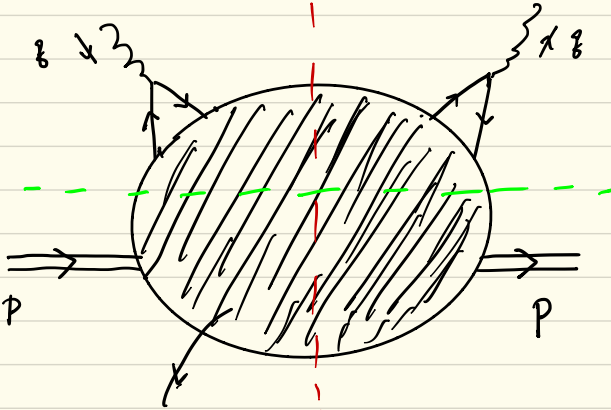

complicated Feynman diagrams,  $g, \bar{g}, G$ .

Classification of diagrams:

Dividing a given diagram into two parts, (green line)

Upper part: containing the two photon external lines.

lower-part: " the two hadron external lines.

two parts are connected with internal lines  
of quarks and gluons



3.8.

(2PR)

The diagrams are classified as 2-particle reducible,

3PR- ... nPR- diagrams, (one-PR?)

Structure of diagrams: (nPR)

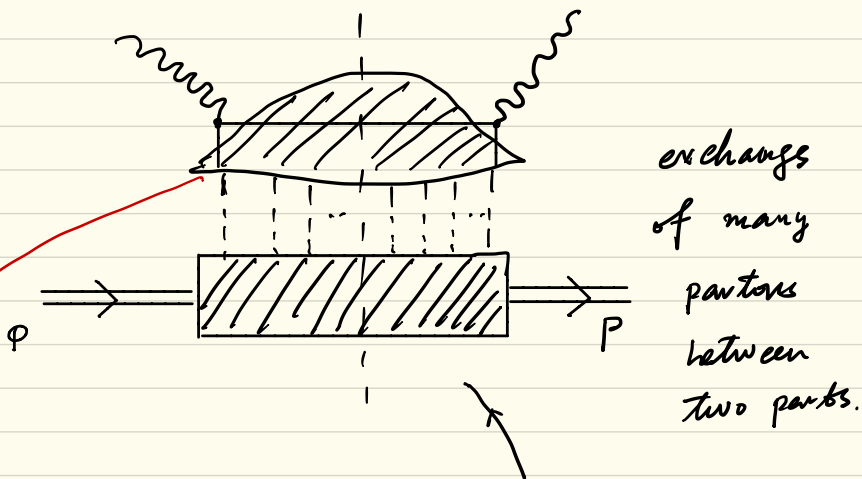

..... : lines for quarks or gluons.

The lower-part is the matrix elements of hadron sandwiched with operators represented by those lines.

The upper-part can be classified into tree-level, one-loop- ... n-loop diagrams.

3.P.

Tree-level of upper-part:

2-PR: only one diagram,

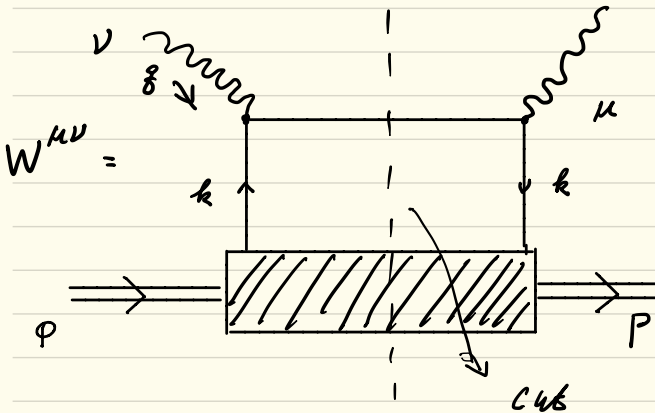

"hand-bag diagram"

The black box

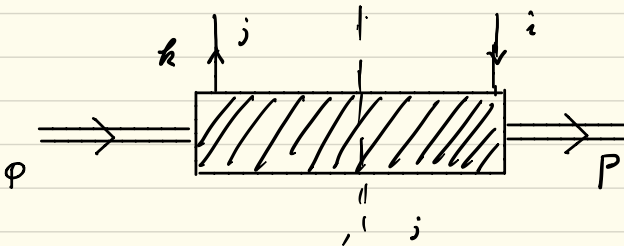

"jet function"

$$= \Gamma_{ji}(k, P) = \int d^4x e^{-ik \cdot x} \langle h(P) | \bar{\delta}_i(x) \delta_j(0) | h(P) \rangle$$

$i, j$ : Indices of spinor and color.

3.10.

Expanding around  $k^\mu = \hat{k}^\mu (1 + O(\lambda))$ ,

$$\hat{k}^\mu = (k^+, 0, 0, 0)$$

The hand-bag diagram:

$$W^{\mu\nu} = \frac{1}{2} \int \frac{d^4 k}{(2\pi)^4} (\gamma^\mu \gamma \cdot (k + \not{z}) \gamma^\nu \delta((k + \not{z})^2))_{ij} \Gamma_{ij}(k, P),$$

For  $\Gamma(k, P)$ : In the case of  $P^+ \rightarrow \infty$ ,  $P^\mu \approx (P^+, 0, 0, 0)$ ,

the dominant contribution comes from the region:

$$k^\mu \sim Q(1, \lambda^2, \lambda, \lambda), \quad \lambda = \frac{\Lambda}{Q} \ll 1.$$

Power counting for parton momentum,  $\Lambda \sim \Lambda_{QCD}, m_q, \dots$

$$W^{\mu\nu} = \frac{1}{2} \int dk^+ (\gamma^\mu \gamma \cdot (\hat{k} + \not{z}) \gamma^\nu)_{ij} \delta((\hat{k} + \not{z})^2) \int \frac{dx^-}{2\pi} e^{-i k^+ x^-} \langle h(P) | \bar{\psi}_i(x^- n) \psi_j(0) | h(P) \rangle + O(\lambda) + \dots$$

The quark field:  $i \not{\partial} \psi = (i D^+ \not{\sigma}^- + i D^- \not{\sigma}^+ - i \vec{\sigma}_\perp \cdot \vec{D}_\perp) \psi(x) = 0$

in the hadron

$$\begin{matrix} \uparrow & \uparrow & \uparrow \\ O(P^+) & O(\lambda^2) & O(\lambda), \end{matrix}$$

↓

3.11

Not all components of  $\mathcal{F}(x)$  are important.

$$\mathcal{F}(x) = \mathcal{F}^{(+)}(x) + \mathcal{F}^{(-)}(x),$$

$$\mathcal{F}^{(+)}(x) = \frac{1}{2} \delta^- \delta^+ \mathcal{F}(x),$$

$$\mathcal{F}^{(-)}(x) = \frac{1}{2} \delta^+ \delta^- \mathcal{F}(x),$$

$$\delta^- \delta^+ + \delta^+ \delta^- = 2, \quad \delta^- \delta^- = \delta^+ \delta^+ = 0.$$

Using EOM:  $\mathcal{F}^{(-)} \sim O\left(\frac{\Lambda}{p^+}\right) \mathcal{F}^{(+)}$ .

Power-counting for  $\mathcal{F}$ .

$\Rightarrow \mathcal{F}^{(+)}(x)$  is the large component.

$$\int \frac{dx^-}{2\pi} e^{-ik^+ x^-} \langle h(P) | \bar{\mathcal{F}}_i(x^-) \mathcal{F}_j(0) | h(P) \rangle$$

$$= \frac{1}{2N_c} (\delta^-)_{ji} f_{\mathcal{F}/p}(\bar{z}) + O(\Lambda),$$

color diagonal.

PDF:  $f_{\mathcal{F}/p}(\bar{z}) = \frac{1}{2} \int \frac{d\lambda}{2\pi} e^{-ik^+ \lambda} \langle h(P) | \bar{\mathcal{F}}(\lambda) \delta^+ \mathcal{F}(0) | h(P) \rangle,$

↑

dimensionless, depends only on  $k^+/p^+ = \bar{z}$ .

momentum conservation:  $-P^+ < k^+ < P^+$ ,

$k^+ < 0$ : antiquark. We take  $k^+ > 0$

$$(\hat{k} + \not{z})^2 = 2(\hat{k} + \not{z})^+ \not{z}^- = 0$$

$$\Rightarrow k^+ + z^+ = 0, \quad (\hat{k} + \not{z})^\mu = (0, \not{z}^-, 0, 0) \quad !!$$

3.12

$$W^{\mu\nu} = \frac{1}{4N_c} \int_0^{P^+} dk^+ f_{z/p}(z) \delta((\hat{k} + \not{z})^2) \text{Tr}[\not{\sigma}^\mu \not{\sigma} \cdot (\hat{k} + \not{z}) \not{\sigma}^\nu \not{\sigma}^-],$$

$$\Rightarrow F_1(x, Q^2) = \frac{1}{2} \int_0^1 dz \delta(x-z) f_{z/p}(z) = \frac{1}{2} f_{z/p}(x),$$

$$F_2(x, Q^2) = 2x F_1(x, Q^2) = x f_{z/p}(x) \quad \#$$

But:

$$f_{z/p}(z) = \frac{1}{2} \int \frac{d\lambda}{2\pi} e^{-i\lambda^+ z} \langle h(P) | \bar{\psi}(\lambda^+) \not{\sigma}^+ \psi(0) | h(P) \rangle$$

*It is not gauge invariant!*

In fact, at tree-level there are many diagrams at the leading order of  $1$  or  $\lambda = \frac{1}{P^+} !!$

E.g.:

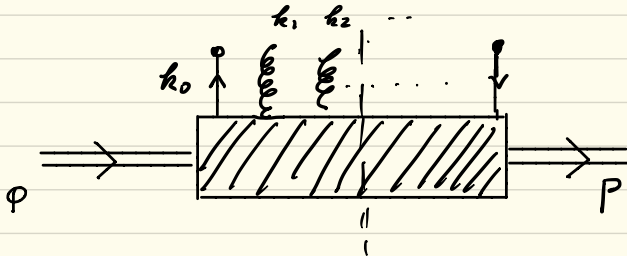

3.13

a: 3-PR diagram

The case of one gluon:

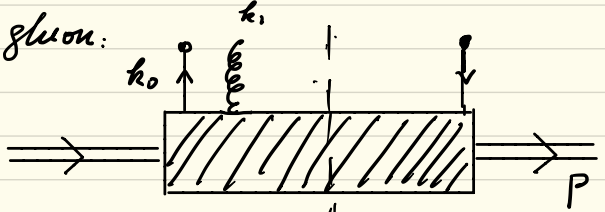

Power counting:

$$FT: \langle h(P) | \bar{\psi}(x_0) G^\mu(x_1) \psi(0) | h(P) \rangle$$

$$\sim P^+ \left( 1, \frac{\Lambda^2}{(P^+)^2}, \frac{\Lambda}{P^+}, \frac{\Lambda}{P^+} \right) \sim k_{0,1}^\mu$$

$\mu = +$ : The largest component.

The contribution to  $W^{\mu\nu}$ :

After expansion in

$\lambda$ :

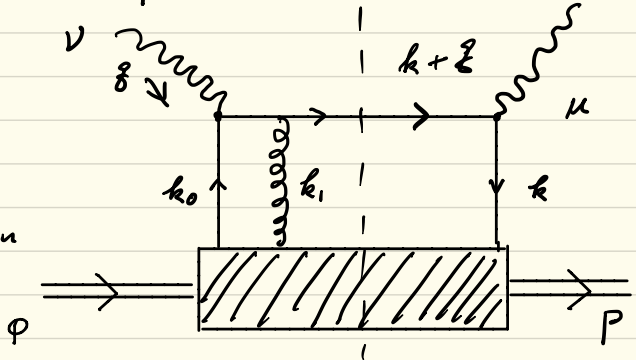

$$W_{ig}^{\mu\nu} = \frac{1}{2} \int d\hat{k}^+ d\hat{k}_1^+ \left[ \delta^\mu \delta \cdot (\hat{k} + \hat{g}) (-i g_s \delta^-) \frac{i \delta \cdot (\hat{k} + \hat{g} - \hat{k}_1)}{(\hat{k} + \hat{g} - \hat{k}_1)^2 + i\epsilon} \right. \\ \left. \cdot \delta^\nu \delta((\hat{k} + \hat{g})^2) \right]_{ij} \frac{1}{2N_c} (\delta^-)_j \\ \cdot \int \frac{d\lambda d\lambda_1}{(2\pi)^2} e^{-i\lambda \hat{k}^+ + i\lambda_1 \hat{k}_1^+} \langle h | \bar{\psi}(\lambda u) \gamma^+ G^+(\lambda_1 u) \psi(0) | h \rangle,$$

3.14

$$\hat{k} = (k^+, 0, 0, 0), \quad \hat{k}_i = (k_i^+, 0, 0, 0), \quad \rho = -$$

$$\delta^\rho \frac{\delta \cdot (\hat{k} + \delta - \hat{k}_i)}{(\hat{k} + \delta - \hat{k}_i)^2 + i\epsilon} \delta^\nu \delta^- = \delta^\nu \delta^- \frac{1}{-k_i^+ + i\epsilon} n^\rho$$

Note:  $\nu = \perp$  and  $k^+ + \delta^+ = 0$ , on-shell.

$$\begin{aligned} \Rightarrow W_{i\delta}^{\mu\nu} &= \frac{1}{4N_c} \int d^4k \left[ \text{Tr} \left( \delta^\mu \delta \cdot (\hat{k} + \delta) \delta^\nu \delta^- \right) \delta \left( (\hat{k} + \delta)^2 \right) \right] \\ &\quad \cdot \frac{1}{2} \int d^4k_i^+ \frac{i}{-k_i^+ + i\epsilon} (-i g_s n_\rho) \int \frac{d\lambda d\lambda_1}{(2\pi)^2} e^{-i\lambda k^+ + i\lambda_1 k_i^+} \\ &\quad \langle k | \bar{g}(\lambda n) \delta^+ G^\rho(\lambda_1 n) g(0) | k \rangle, \end{aligned}$$

$n_\rho G^\rho = G^+$ , the factor in  $[\dots]$  is the same as before.

One can work out the results for exchanges of  $m$ -gluons.

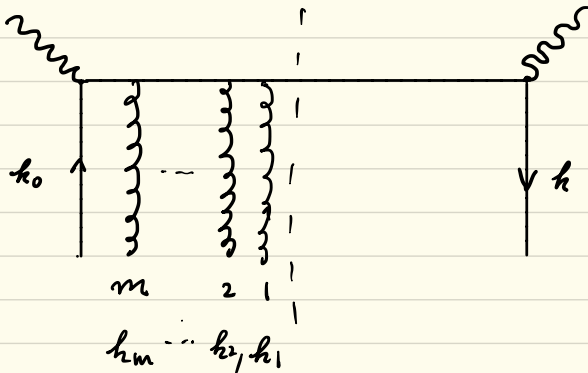

3.15

The same [ -- ] !!

The contribution with  $m$ -gluons:

$$\begin{aligned}
 W_{m g}^{\mu\nu} &= \frac{1}{4N_c} \int d\mathbf{k}^+ \left[ \text{Tr} \left( \delta^\mu \delta \cdot (\hat{\mathbf{k}} + \mathbf{g}) \delta^\nu \delta^- \right) \delta \left( (\hat{\mathbf{k}} + \mathbf{g})^2 \right) \right] \\
 &\quad \frac{1}{2} \int \prod_{i=1}^m d\mathbf{k}_i \frac{\delta_s}{(-\mathbf{k}_1^+ + i\varepsilon)} \frac{\delta_s}{(-\mathbf{k}_2^+ + i\varepsilon)} \cdots \frac{\delta_s}{(-\mathbf{k}_m^+ + i\varepsilon)} \\
 &\quad \int \frac{d\lambda}{2\pi} e^{-i\lambda \varepsilon^+} \prod_{i=1}^m \frac{d\lambda_i}{2\pi} e^{+i\lambda_i \mathbf{k}_i^+} \\
 &\quad \langle h(p) | \bar{g}(\lambda n) \delta^+ G^+(\lambda_1 n) G^+(\lambda_2 n) \cdots G^+(\lambda_m n) g(0) | h(p) \rangle,
 \end{aligned}$$

$$\hat{\mathbf{k}}_i^+ = \mathbf{k}_1^+ + \mathbf{k}_2^+ + \cdots \mathbf{k}_i^+ \quad \begin{array}{l} \rightarrow \text{ordered} \\ \text{"statistical factor"} \end{array}$$

The contributions are at the same order of  $\Lambda$  !!

need to be summed.

Gauge link: path-ordered along  $n$ -direction

$$\begin{aligned}
 V(x, \infty) &= P \exp \left\{ -i g_s \int_0^\infty d\lambda G^+(\lambda n + x) \right\} \\
 &= 1 + \sum_{i=1} (-i g_s)^i \int \prod_{j=1}^i d\lambda_j G^+(\lambda_1 n + x) G^+(\lambda_2 n + x) \\
 &\quad G^+(\lambda_3 n + x) \cdots G^+(\lambda_j n + x) \cdot \theta(\lambda_1 - \lambda_2) \theta(\lambda_2 - \lambda_3) \\
 &\quad \theta(\lambda_3 - \lambda_4) \cdots \theta(\lambda_{j-1} - \lambda_j) \theta(\lambda_j),
 \end{aligned}$$



3.16

Using 
$$O(\lambda) = i \int \frac{dW}{2\pi} \frac{e^{-iW\lambda}}{W+i\epsilon}$$

$$V(x, \infty) = 1 + \sum_{i=1}^{\infty} (-i g_s)^i \int \prod_{j=1}^i \frac{d\lambda_j}{2\pi}$$

$$\frac{i}{(-k_1^+ + i\epsilon)} \frac{i}{(-\tilde{k}_2^+ + i\epsilon)} \frac{i}{(-\tilde{k}_3^+ + i\epsilon)} \dots \frac{i}{(-\tilde{k}_i^+ + i\epsilon)}$$

$$\cdot \prod_{j=1}^i \frac{d\lambda_j}{2\pi} e^{i\tilde{k}_j^+ \lambda_j} G^+(\lambda_1, n+x) G^+(\lambda_2, n+x) \dots G^+(\lambda_i, n+x),$$

$\Rightarrow \sum_{m=0}^{\infty} W_{mg}^{\mu\nu}$  can be summed with  $V$ . the left part.

Doing the same for the right part

After the sum: the leading order of  $\lambda$  is tree-level:

$$W^{\mu\nu} = \frac{1}{4N_c} \int d\tilde{k}^+ \text{Tr} \left[ \gamma^\mu \sigma \cdot (\hat{\tilde{k}} + \not{g}) \gamma^\nu \gamma^- \right] g((\hat{\tilde{k}} + \not{g})^2)$$

$$\cdot \frac{1}{2} \int \frac{d\lambda}{2\pi} e^{-i\lambda \tilde{k}^+} \langle h | \bar{g}(\lambda, n) V^+(\lambda, \infty) \gamma^+ V(0, \infty) g(0) | h \rangle$$

The gauge invariant definite of PDF:

$$f_{g/p}(z, \mu) = \frac{1}{2} \int \frac{d\lambda}{2\pi} e^{-i\lambda \tilde{k}^+} \langle h | \bar{g}(\lambda, n) V^+(\lambda, \infty) \gamma^+ V(0, \infty) g(0) | h \rangle$$

$$\tilde{k}^+ = z P^+$$

3.17.

$\mu$ : renormalization scale, introduced by V.V. subtraction. Because of the subtraction, one can not show that PDF is positive as a probability.!

Gauge transformation:

$$g(x) \rightarrow u(x) g(x), \quad V(x, \infty) \rightarrow u(\infty) V(x, \infty) u^\dagger(x).$$

The defined PDF is gauge invariant!

Is the obtained  $W^{\mu\nu}$  gauge invariant??

We need to check the factor  $\text{Tr}[\delta^\mu \delta \cdot (\hat{k} + g) \delta^\nu \delta^-]$   
with  $(\hat{k} + g)^2 = 0$ .

$$\frac{1}{2N_G} \text{Tr}[\delta^\mu \delta \cdot (\hat{k} + g) \delta^\nu \delta^-] = \frac{1}{k^+} \sum' \bar{u}(\hat{k}) \delta^\mu u(\hat{k} + g) u(\hat{k} + g) \delta^\nu u(\hat{k})$$

$$\hat{k}^2 = 0$$

$u(\hat{k} + g) \delta^\nu u(\hat{k})$ : the scattering amplitude for  
 $\delta^+ + g(\hat{k}) \rightarrow g(\hat{k} + g)$

Therefore, the obtained  $W^{\mu\nu}$  is gauge invariant.

3.18

- For gauge invariance it is crucial that the initial quark is on-shell! It is also important for summing of collinear gluons by Ward identity beyond tree-level to prove the factorization.

To include antiquark contributions:  $z < 0$ .

$$f_{\bar{q}/p}(z) = -f_{q/p}(-z).$$

$$F_2(x, Q^2) = x \left( f_{q/p}(x) + f_{\bar{q}/p}(x) \right)_{\#}$$

To discuss the factorization beyond tree-level, we modify the notation of the "black box".

After summing all gluons, our result can be given as:

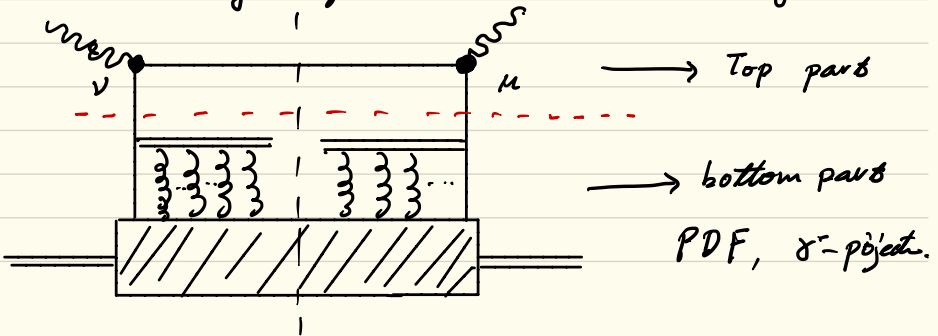

3.18

Feynman rule for  $V(x, \infty)$ :

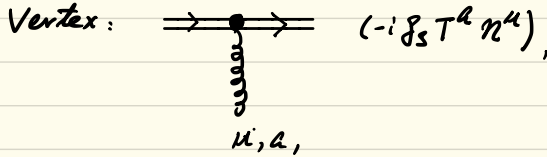

Propagator:

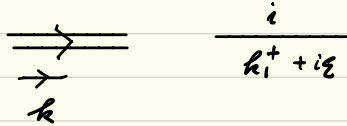

Beyond tree-level:

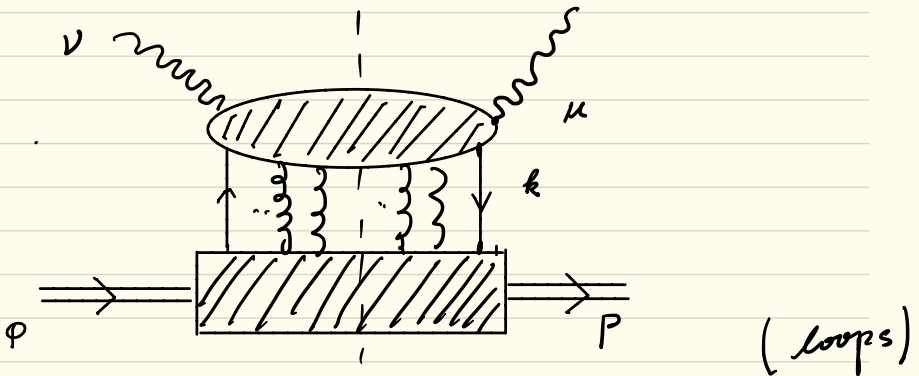

The top bubble can be at any order of  $\alpha_s$ .

We have studied the case at order  $\alpha_s^0$ .

3.20.

We need to sum all contributions of gluon exchanges.

After the collinear expansion: All parton lines carries "+" momentum  $\hat{k} = (\hat{k}^+, 0, 0, 0)$ ,

the quark lines are for on-shell quarks.

The gluon lines are for  $G^+$  gluons!

In covariant gauge, one can derive

Ward identity: (BRST)

$$\langle f | \partial^{\mu_1} G_{\mu_1}(x_1) \partial^{\mu_2} G_{\mu_2}(x_2) \dots \partial^{\mu_n} G_{\mu_n}(x_n) | i \rangle = 0$$

$n = 1, 2, 3 \dots$ , matrix relation!

$|i\rangle, |f\rangle$ , physical states, on-shell !!

3.21

Illustration: one gluon attachment, one quark in the initial state

$$p^\mu = (p^+, 0, 0, 0)$$

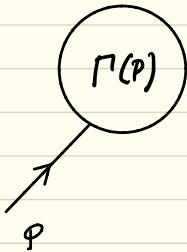

$$\langle f | \not{p}(p) \rangle = \Gamma(p) u(p)$$

One-gluon insertion:

$$\langle f | \partial_\mu G^{a,\mu}(x) | i \rangle = 0.$$

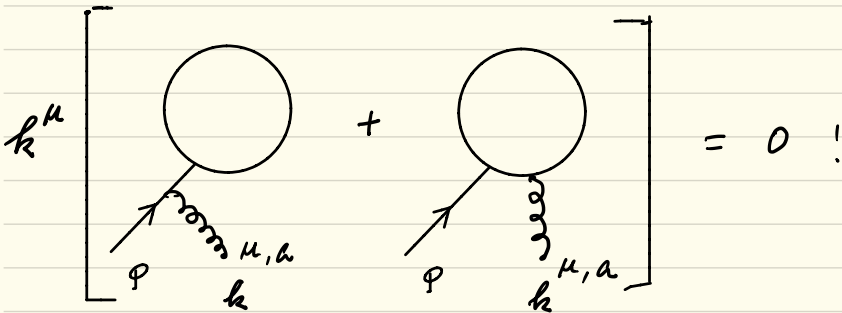

(a)

(b)

(b): All possible insertions except (a).



3.22

We decompose

$$G^{a,\mu}(k) = \int d^4x e^{ik \cdot x} G^{a,\mu}(x)$$

$$= \frac{k^\mu}{n \cdot k} n \cdot G^a(k) + \left( G^{a,\mu}(k) - \frac{k^\mu}{n \cdot k} n \cdot G^a(k) \right)$$

↑  
scalar gluon, longitudinal polarised.

All possible attachment of scalar gluon in (b) = Attachment to the external leg.

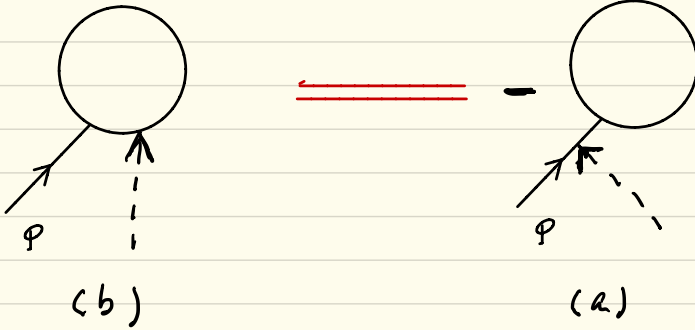

$$\text{Fig. (a)} = (-) \frac{1}{n \cdot k} \Gamma(p+k) \frac{i \delta \cdot (p+k)}{(p+k)^2 + i\epsilon} (-i g_s \delta \cdot k T^a) u(p)$$

$$= - \frac{g_s}{n \cdot k} \Gamma(p+k) T^a \left[ 1 - \frac{\delta \cdot (p+k)}{(p+k)^2 + i\epsilon} \delta \cdot p \right] u(p)$$

↑  
 $\delta \cdot p u(p) = 0 \sim 0$

3.23.

$$\text{Fig. (a)} = - \frac{\delta s}{n \cdot k} \Gamma(p+k) T^a U(p) \quad \text{for on-shell gluon.}$$

In our case:  $k^\mu \sim (1, \lambda^2, \lambda, \lambda),$

$$G^\mu \sim (1, \lambda^2, \lambda, \lambda).$$

$$\Rightarrow G^\mu(k) = \frac{k^\mu}{k^+} G^+ (1 + O(\lambda)),$$

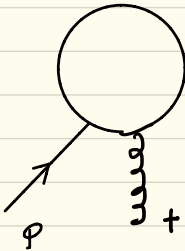

(b)

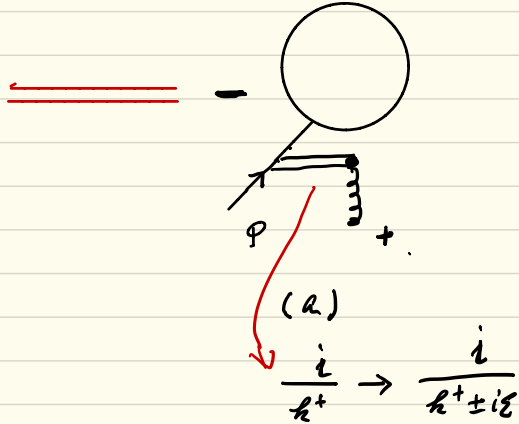

This can be generalised to insertion of any number of gluons. The sum gives gauge links.

$\pm i\epsilon$  irrelevant here



3.24

With Ward-Identity, the leading contribut from the sum of

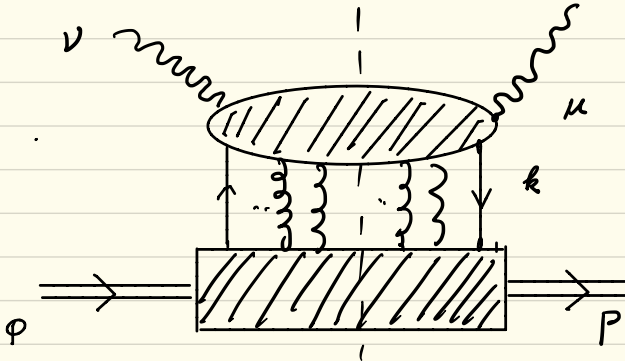

is given by:

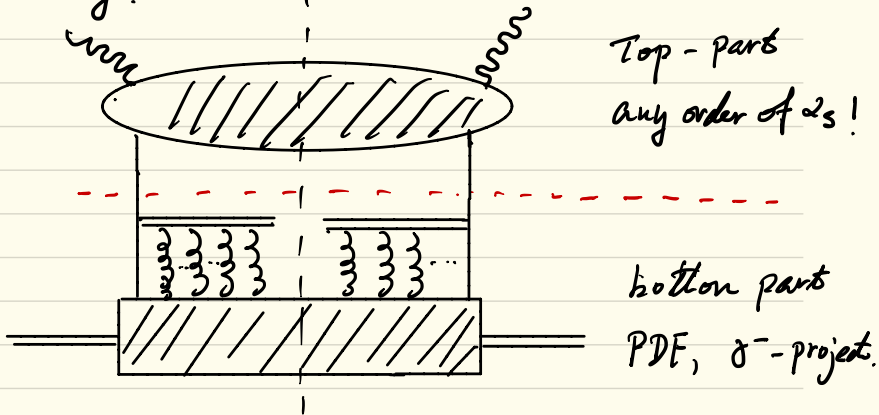

**Note:** crucial that the quark lines stand for on-shell quarks.

3.25

At one-loop level, the top part:

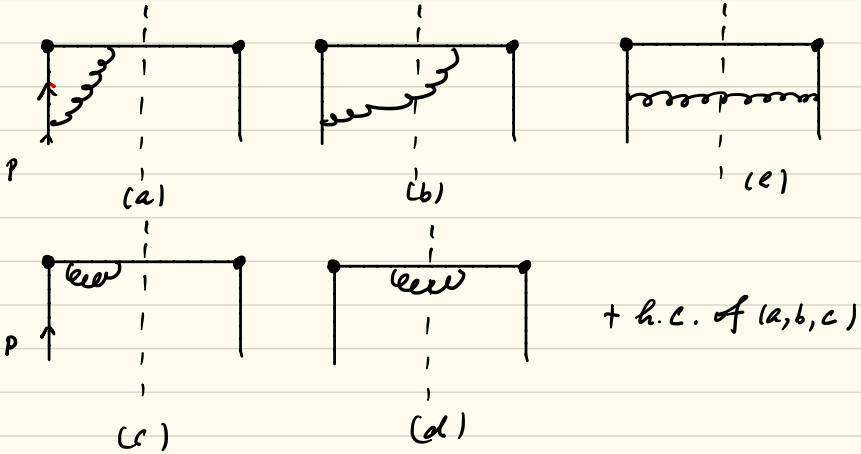

With the projection from the bottom:

$$\frac{1}{2N_c} (\gamma^-)_i; f_{g/p}(z), \quad \hat{p}^\mu = z P^\mu$$

After the projection and taking  $\hat{p}^\mu = (\hat{p}^+, 0, 0, 0)$ ,  
the initial quark lines stand for on-shell quarks.

- We will use the subtractive approach (Collins), it has a similarity to BHP for U.V.

3.26

Consider Fig. (a):

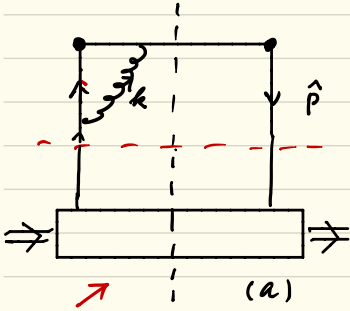

The black box + gauge links

$$W_a^{\mu\nu} = \frac{1}{4N_c} \int d\hat{P}^+ \delta((\hat{P}+\mathcal{E})^2)$$

$$\int \frac{d^4k}{(2\pi)^4} \frac{-i}{k^2+i\epsilon} \text{Tr} \left[ \gamma^\mu \gamma \cdot (\hat{P}+\mathcal{E}) \right]$$

$$(-i g_s \gamma^\rho T^a) \frac{i \delta \cdot (\hat{P}+\mathcal{E}-k)}{(\hat{P}+\mathcal{E}-k)^2+i\epsilon} \gamma^\nu$$

$$\frac{i \delta \cdot (\hat{P}-k)}{(\hat{P}-k)^2+i\epsilon} (-i g_s \gamma_\rho T^a) \gamma^- \cdot f_{\mathcal{E}/P}(\mathcal{E})$$

$$\hat{P}^+ = \mathcal{E} P^+$$

Consider the momenta region  $k^\mu \sim (1, \lambda^2, \lambda, \lambda)$ , collinear to  $\hat{P}$  or  $P$ . Expanding in  $\lambda$ ,

the leading order is:

$$W_{a,c}^{\mu\nu} = \frac{1}{4N_c} \int d\hat{P}^+ \delta((\hat{P}+\mathcal{E})^2) \text{Tr} \left[ \gamma^\mu \gamma \cdot (\hat{P}+\mathcal{E}) \gamma^\nu \gamma^- \right]$$

$$\cdot \left\{ \int \frac{d^4k}{(2\pi)^4} \frac{-i}{k^2+i\epsilon} \text{Tr} \left[ \gamma^+ \frac{i \delta \cdot (\hat{P}-k)}{(\hat{P}-k)^2+i\epsilon} (-i g_s \gamma_\rho T^a) \gamma^- \right] \right.$$

$$\cdot \left. \frac{i}{-k^2+i\epsilon} (-i g_s \gamma^\rho T^a) \frac{1}{4N_c} f_{\mathcal{E}/P}(\mathcal{E}) \right\}$$

The integration over  $k$  is divergent,

Note ..... is tree-level results. | collinear divergence!

3.27

This collinear divergent contribution is represented by the diagram:

$$W_{a,c}^{\mu\nu} =$$

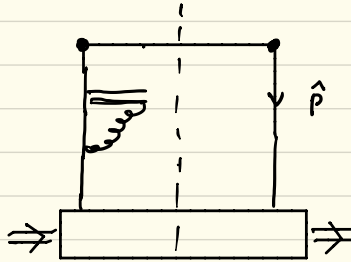

In the tree-level, there is the same contribution:

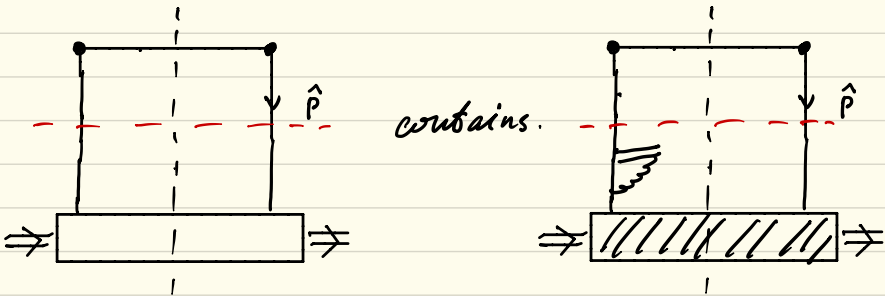

Including  $W_{a,c}^{\mu\nu}$  at one-loop results in a double counting. To avoid it,  $W_{a,c}^{\mu\nu}$  must be subtracted. (subtractive approach).

3.28

⇒ The contribution from Fig. (a) at one-loop is given by:

$$W_a^{\mu\nu} - W_{a,c}^{\mu\nu}$$

It is free from the collinear singularity from the region where the gluon is collinear to  $P$  !!

Fig. (c):

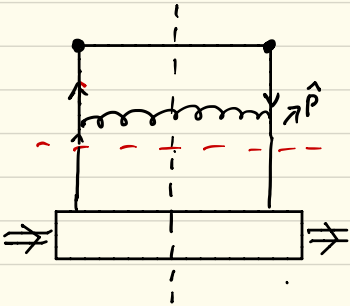

$$\begin{aligned}
 W_c^{\mu\nu} &= \frac{1}{4N_c} \int d\hat{P}^+ \int \frac{d^4k}{(2\pi)^4} f((\hat{P} + \hat{z} - k)^2) \\
 &\cdot \text{Tr} \left[ (i g_s \not{\partial} \not{P} T^a) \frac{-i \delta \cdot (\hat{P} - k)}{(\hat{P} - k)^2 - i\epsilon} \right. \\
 &\quad \left. \delta^\mu \delta \cdot (\hat{P} + \hat{z} - k) \delta^\nu \frac{i \delta \cdot (\hat{P} - k)}{(\hat{P} - k)^2 - i\epsilon} \right. \\
 &\quad \left. (-i g_s \not{\partial}_\rho T^a) \delta^- \right] \\
 &\quad (-2\pi \delta(k^2)) f_{\hat{z}/\hat{P}}(\hat{z})
 \end{aligned}$$

Consider the contribution from the collinear region with  $k^\mu \sim (1, \lambda^2, \lambda, \lambda)$ ,

3.2f

The collinearly divergent contribute of Fig. (e):

$$\begin{aligned}
 W_{e,c}^{\mu\nu} &= \frac{1}{4N_c} \int d\hat{k}^+ \delta((\hat{k} + \hat{g})^2) \text{Tr} \left[ \gamma^\mu \hat{\sigma} \cdot (\hat{k} + \hat{g}) \hat{\sigma}^\nu \hat{\sigma}^- \right] \\
 &\quad \left\{ \frac{d^4 k}{(2\pi)^4} (-2\pi \delta(k^2)) \text{Tr} \left[ \hat{\sigma}^+ \frac{i\hat{\sigma} \cdot (\hat{p} - \hat{k})}{(\hat{p} - \hat{k})^2 + i\epsilon} (-i\hat{g}_s \hat{\sigma}_\rho T^a) \right. \right. \\
 &\quad \left. \left. \cdot \hat{\sigma}^- \frac{-i\hat{\sigma} \cdot (\hat{p} - \hat{k})}{(\hat{p} - \hat{k})^2 - i\epsilon} (i\hat{g}_s \hat{\sigma}^\rho T^a) \right] \frac{1}{4N_c} f_{g/p}^z(z), \right.
 \end{aligned}$$

$$\hat{k}^\mu = (\hat{p}^+ - \hat{k}^+, 0, 0, 0).$$

Again, there is a double counting. For the collinear gluon, there is the same contribution in tree level results:

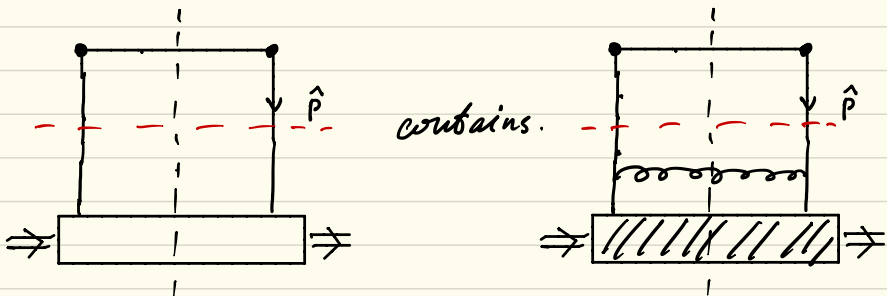

Subtraction is needed.

3.30

⇒ The contribution from Fig. (e) at one-loop

$$W_e^{\mu\nu} - W_{e,c}^{\mu\nu}$$

It is free from the collinear divergence!

Only Fig. (a), (b) and (c) contain the divergences when the exchanged gluon is collinear to P.

Doing the same for Fig. (b) .....

⇒ The contribution to  $W^{\mu\nu}$  hasn't the collinear divergences.

There are I.R. divergences in each diagram.

They are cancelled in the sum, because we sum all final states, as discussed in Sect. 2.

There are collinear divergences when the exchanged gluon is collinear to the final quark.

They are cancelled as I.R. one's

3.3.1.

**Conclusion:** The perturbative coefficients function  $C_g$  in  $W^{\mu\nu}$  at one-loop is finite!

At one-loop, there are gluonic contribution

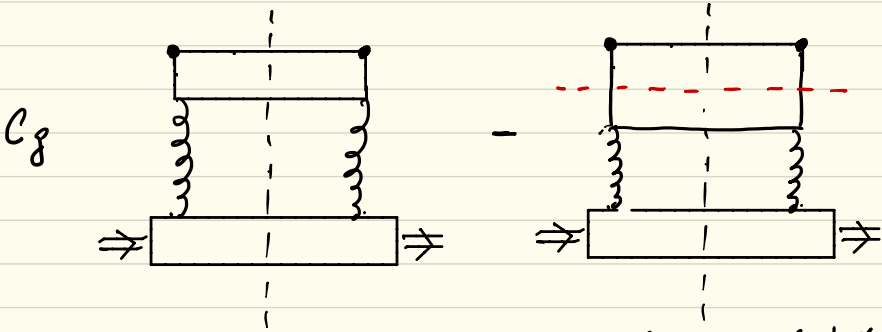

Gluon PDF:

$$f_{g/p}(z) = -\frac{1}{z p^+} \int \frac{d\lambda}{2\pi} e^{-i\lambda p^+ z}$$

$$\langle h(p) | (G^{+\mu}(\lambda n) V^+(\lambda n, 0)) \left( V(0, \infty) G^{+\mu}(0) \right)^2 | h(p) \rangle$$

collinear contribution  
is already included  
in tree-level  
diagram

$V$ : in adjoint representation.

One can show  $C_g$  is finite at one-loop.



3.32

One can go iteratively beyond one-loop,  
and show the factorization:

$$F_2(x, Q^2) = x \sum_a \int_x^1 \frac{d\xi}{\xi} C_a\left(\frac{x}{\xi}, Q^2, \mu^2\right) f_{q/h}\left(\frac{\xi}{Q^2}, \mu^2\right) + \dots$$

$$= x \sum_a C_a \otimes f_{q/h} \left( 1 + O\left(\frac{\Lambda^2}{Q^2}\right) \right),$$

The operators used to define PDF are twist-2 operators.

Theoretical predictions?

$\mu \rightarrow \infty, \alpha_s \rightarrow 0.$

Evolution: DGLAP

Bjorken scaling.

$$\frac{\partial}{\partial \ln \mu^2} \begin{pmatrix} f_{g/p}(x) \\ f_{g/p}(x) \end{pmatrix} = \frac{\alpha_s}{2\pi} \int_x^1 \frac{d\xi}{\xi} \begin{pmatrix} P_{gg}(z), P_{gq}(z) \\ P_{qg}(z), P_{qq}(z) \end{pmatrix} \begin{pmatrix} f_{g/p}(\xi) \\ f_{g/p}(\xi) \end{pmatrix},$$

$z = \frac{x}{\xi}$ ,  $P_{ab}(z)$ : splitting kernel.

$P_{ab}$  can be calculated with perturbative theory,  
known at three-loop level.

3.33

$$F_i(x, Q^2) = \sum_a C_a(\mu^2, Q^2) \otimes f_{g/p}(\mu^2),$$

$C_a$  depend on  $\ln \frac{\mu^2}{Q^2}$ ,  $C_a(\mu^2, Q^2) = C_a(\frac{\mu^2}{Q^2})$ ,

Taking  $\mu^2 = Q^2$ ,  $F_i(x, Q^2) = \sum_a C_a(1) \otimes f_{g/p}(Q^2)$ ,

$Q^2$ -dependence is determined by DGLAP.

Bjorken scaling:  $F_i(x, Q^2) = F_i(x)$ ,

Scaling violation is predicted.

The prediction agrees with experiments.  $\implies$

Experiment of unpolarized DIS has told us:

- ① Partons are quarks and gluons
- ② Scaling violation from experiments is predicted correctly.
- ③ Extract PDF's for other usages.

"Classical test of QCD"

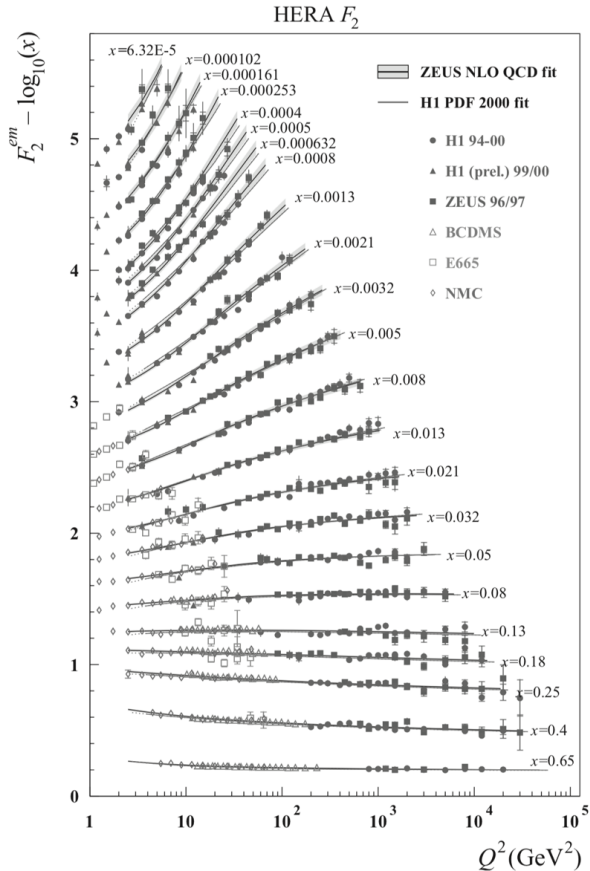

Fig. 2.7. Compilation of the world  $F_2$  data for DIS on a proton. The proton  $F_2$  structure function is plotted as a function of  $Q^2$  for a range of values of  $x$ , as indicated next to the data. It can be seen that, except for very small  $x$ ,  $F_2$  is independent of  $Q^2$ , a manifestation of Bjorken scaling. (We thank Kunihiro Nagano for providing us with this figure.) A color version of this figure is available online at [www.cambridge.org/9780521112574](http://www.cambridge.org/9780521112574).

3.25

polarized DIS with proton:

The proton is polarized, a spin vector  $s$

The decomposition:

$$W^{\mu\nu}(P, \xi) = \left(-g^{\mu\nu} + \frac{\xi^\mu \xi^\nu}{\xi^2}\right) F_1(x, Q^2) + \frac{\hat{p}^\mu \hat{p}^\nu}{P \cdot \xi} F_2(x, Q^2) \\ + i \epsilon^{\mu\nu\alpha\beta} \frac{\xi_\alpha}{P \cdot \xi} \left[ S_\beta g_1(x, Q^2) \right. \\ \left. + (P \cdot \xi S_\beta - \xi \cdot S P_\beta) g_2(x, Q^2) \right],$$

Two additional structure functions.

$g_1$ : can be measured with longitudinally polarized proton. Its factorization is similar to that of  $F_i$  with twist-2 operators.

experimental study of  $g_1$ :

"Spin crisis"

3.36

$g_2$ : can be measured with transversely polarized proton. Its factorization is with twist-3 operators, complicated.

#

Momentum sum rule

Spin sum rule



3.38

$\pm i\varepsilon$  has a physical meaning:

$+i\varepsilon$ : final state interaction

This leads to that PDF defined in DIS

is with the gauge link  $V(x, \infty)$

pointing to the future.

$-i\varepsilon$ : Initial state interaction

This leads to that PDF defined in DY

is with the gauge link  $V(x, -\infty)$

pointing to the past.

PDF in DY:

$$V(x, -\infty) = P \exp \left\{ -i g_s \int_{-\infty}^0 d\lambda G^+(\lambda n + x) \right\},$$

$$\left. \int \frac{d^2z}{P} (\bar{z}) \right|_{DY} = \frac{1}{2} \int \frac{d\lambda}{2\pi} e^{-i\lambda P_A^+ z} \langle h_A | \bar{z}(n) V(\lambda n, -\infty) \bar{z}^+ V^+(0, -\infty) z(0) | h_A \rangle_{\#}$$

3.3f

Symmetry of Parity + Time-reversal

$$\Rightarrow \boxed{f_{z/p}(z) \Big|_{DY} = f_{z/p}(z) \Big|_{DIS}}$$

5T non-Abelian Stoke theorem

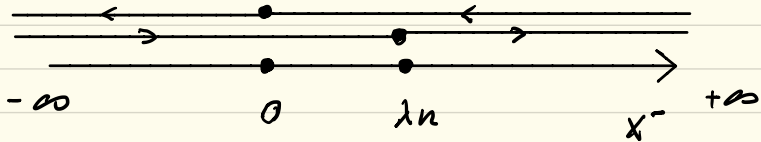

The area inside the close contour is zero!!



3.40

Physical picture of DIS:

Space-time structure of DIS:

rewrite:

$$W^{\mu\nu} = \frac{1}{2\pi} \text{Im} \left[ \int d^4x e^{i\delta x} \langle h(p) | T (J^\mu(x) J^\nu(0)) | h(p) \rangle \right]$$

Forward scattering:

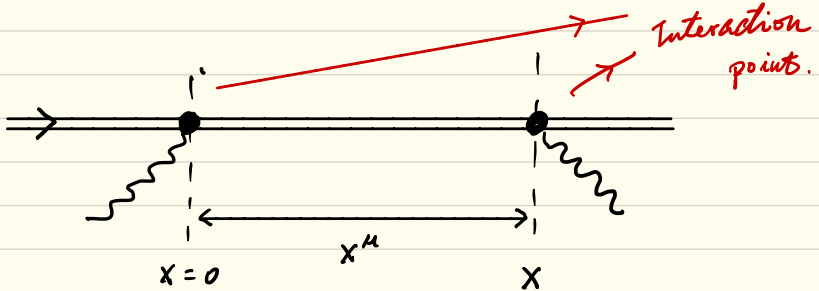

Typical  $x$ -range, interact range, or observation range is given  $\delta \cdot x \sim 1$ .

We take the frame: The initial proton is in rest,

$$p^0 = m, \quad \vec{p} = 0.$$

The virtual photon moves in the  $-\delta$ -direction:

$$\delta^\mu = (\delta^0, 0, 0, \delta^3) = (\delta^0, 0, 0, -|\delta^3|),$$

$$\delta^+ = \frac{1}{\sqrt{2}} (\delta^0 - |\delta^3|), \quad \delta^- = \frac{1}{\sqrt{2}} (\delta^0 + |\delta^3|).$$

3. 41

$$Q^2 \rightarrow \infty, \quad \text{or } Q^2 \gg m^2,$$

$$2P \cdot \not{z} = 2m \not{z}^0 = \frac{Q^2}{x_B} \Rightarrow \not{z}^0 = \frac{Q}{2m x_B} \quad Q \gg Q,$$

$$Q^2 = -\not{z}^2 = -((\not{z}^0)^2 - |\not{z}^3|^2) > 0 \Rightarrow |\not{z}^3| > \not{z}^0.$$

For  $\not{z}^4$ :  $\not{z}^0 \sim |\not{z}^3| \gg Q$ .

$$\not{z}^- \sim \sqrt{2} \not{z}^0, \quad \not{z}^+ = \frac{-Q^2}{2\not{z}^-} \sim -\frac{Q^2}{2\sqrt{2} \not{z}^0} = -\frac{1}{\sqrt{2}} m x_B,$$

The typical range:  $x^- \sim \frac{1}{|\not{z}^+|} \sim \frac{\sqrt{2}}{x_B m} \geq \frac{1}{\Lambda}$ .

$$x^+ \sim \frac{1}{\not{z}^-} \approx \frac{\sqrt{2} x_B m}{Q^2} \ll \frac{1}{\Lambda},$$

$\Lambda$ :  $\Lambda_{\text{QCD}}$ , or  $m$ , soft scale,

$$\text{proton size } R \sim \frac{1}{\Lambda}, \quad x^- = \frac{1}{\sqrt{2}} \frac{1}{\Lambda_{\text{Ioffe}}}$$

Transverse range: Ioffe time.

$$\text{causality } x^2 > 0 \Rightarrow x_{\perp}^2 < 2x^+x^- \sim \frac{4}{Q^2} \ll \frac{1}{\Lambda^2}.$$

3.42

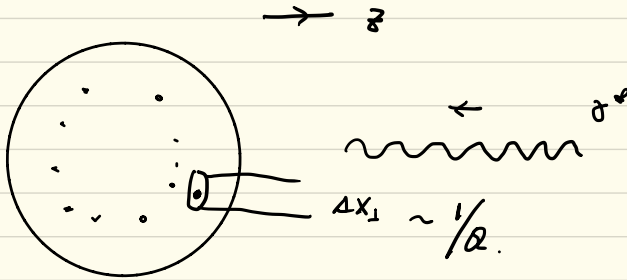

$\Delta x_{\perp}$  small, dominant contribution is from the case of finding one-parton,

The probability to find two partons is power suppressed by  $1/Q$ , part of high-twist effects.

Interaction time: partons inside a hadron in rest, the interaction time between partons: (soft).

$$\tau_p \sim \frac{1}{\Lambda} \sim R.$$

The time range between two interaction points:

$$\tau_{DIS} \sim \frac{1}{z_0} = \frac{2x_B M}{Q^2} \ll \frac{1}{\Lambda}$$

⇒ The photon interacts with a free parton, Physical reason why the factorization can be done.

3. 43

An interesting observation:

$$x^- \sim \frac{1}{18+1} \sim \frac{\sqrt{2}}{x_B m} \geq \frac{1}{\Lambda} \sim R$$

If  $x_B$  is small enough,  $x^- > R$  or  $x^- \gg R$ .

At least, one interaction point is not located inside the hadron. How can the interaction happens outside the hadron?

Hot topic!!

Small- $x$  physics

Section end.



4.1.

## 4. TMD Factorization for SIDIS

Semi-Inclusive DIS (SIDIS):

$$e(k) + h_A(P) \longrightarrow e(k') + h_B(P_h) + X,$$

Kinematics: One-photon-exchange  $q = k - k', \quad q^2 \rightarrow -\infty$

$$\delta^+(\xi) + h_A(P) \longrightarrow h_B(P_h) + X$$

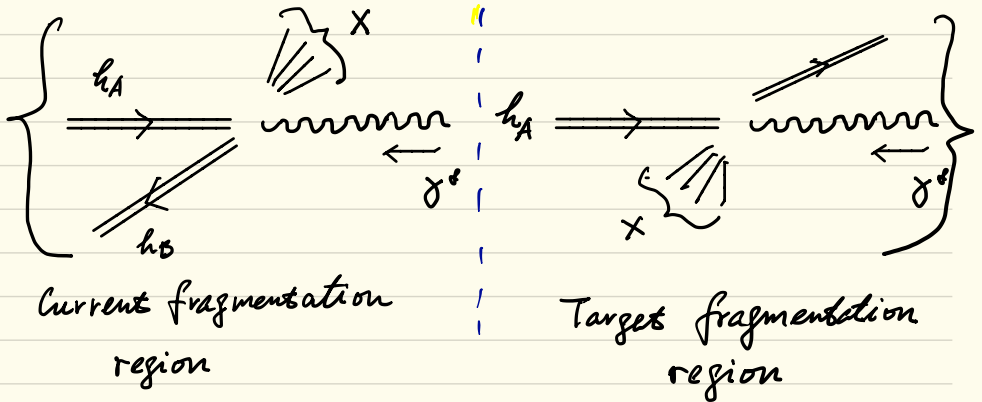

$$P^\mu \approx (P_A^+, 0, 0, 0),$$

"Fracture functions"

$$q^\mu = (\xi^+, \xi^-, 0, 0), \quad \xi^+ < 0.$$

We don't consider this region.

$$P_h^\mu \approx \left( \frac{P_{h\perp}^2}{2P_h^-}, P_h^-, P_{h\perp}^1, P_{h\perp}^2 \right).$$

4.2.

Three kinematical regions.

$\Lambda \sim \Lambda_{QCD}, m_h \dots$   
soft scale.

a.  $P_{h\perp}^2 \sim Q^2 \gg \Lambda^2$ , collinear factorization

$$d\sigma \sim H \otimes f \otimes D \left\{ 1 + O\left(\frac{\Lambda^2}{Q^2}\right) \right\}$$

PDF

FF

H: perturbative coefficient function, finite.

b.  $Q^2 \gg P_{h\perp}^2 \gg \Lambda^2$ , collinear factorization, still.

But: large log's  $\ln \frac{P_{h\perp}^2}{Q^2}$  in H,

resummation is needed.

c.  $Q^2 \gg P_{h\perp}^2 \sim \Lambda^2$ , no collinear factorization.

small  $P_{h\perp}$ : sensitive to transverse momenta of partons, neglected in collinear factorization.

Transverse-Momentum-Dependent factorization  
TMD for c. and b.

4.3.

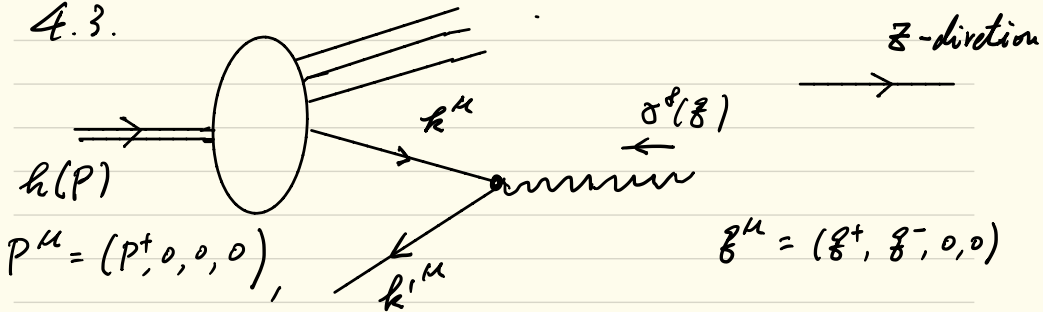

The parton inside  $h$  has the momentum

$$k^\mu = (k^+, k^-, \vec{k}_\perp) \sim (1, \Lambda^2, \Lambda, \Lambda),$$

The outgoing parton has also the transverse momentum  $\vec{k}_\perp' = \vec{k}_\perp$

If we don't observe  $\vec{k}_\perp'$ , i.e.,  $\vec{k}_\perp'$  is integrated, we can make the approximation

by setting  $\vec{k}_\perp = 0$ . This brings an error at

the order  $k_\perp^2/Q^2 \sim \Lambda^2/Q^2 \ll 1$ . like DIS.

If we do observe  $\vec{k}_\perp'$ , it implies that we detect  $\vec{k}_\perp$  of the parton inside the hadron.

$\Rightarrow$  Here we can not set  $\vec{k}_\perp = 0$ . !!



4.4.

Difficulty for defining TMD PDF.

$$h(P), \quad P^\mu \approx (P^+, 0, 0, 0)$$

We re-write the collinear PDF

$$f_{g/p}(x) = \int \frac{d\lambda}{4\pi} e^{-i\lambda k^+} \langle h | \bar{g}(\lambda n) V^+(\lambda n, \infty) \gamma^+ V(0, \infty) g(0) | h \rangle$$

$$k^+ = xP^+ = \int d^2 k_\perp \int \frac{d^3 \tilde{k}}{2(2\pi)^3} e^{-i\tilde{k} \cdot k}$$

$$\langle h | \bar{g}(\tilde{k}) V^+(\tilde{k}, \infty) \gamma^+ V(0, \infty) g(0) | h \rangle$$

$$\tilde{k}^\mu = (0, \tilde{k}^-, \vec{k}_\perp), \quad \tilde{k}^- = \lambda, \quad k^\mu = (k^+, 0, \vec{k}_\perp),$$

Define TMD PDF

$$f_{g/p}(x, \vec{k}_\perp) = \int \frac{d^3 \tilde{k}}{2(2\pi)^3} e^{-i\tilde{k} \cdot k}$$

$$\langle h | \bar{g}(\tilde{k}) V^+(\tilde{k}, \infty) \gamma^+ V(0, \infty) g(0) | h \rangle$$

?

But: The definition is inconsistent !!

4.5

The gauge link:

$$V(\xi, \infty) = P \exp \left\{ -i g_s \int_0^\infty d\lambda G^+(\lambda n + \xi) \right\}$$

Under gauge transformation:

$$V^+(\vec{\xi}, \infty) V(0, \infty) \Rightarrow$$

$$u(\vec{\xi}) V^+(\vec{\xi}, \infty) \underbrace{u^+(\vec{\xi}_\perp, \xi^- = \infty) u(0, \xi^- = \infty)}_{\neq 1 !!} V(0, \infty) u^+(0)$$

$\Rightarrow$  No gauge invariance !!

In fact, in non-singular gauge, like Feynman gauge,  $u(\vec{\xi}_\perp, \xi^- = \infty) = 1$ .

In other gauge, transverse gauge links at  $\xi^- = \infty$  need to be added.

Singular gauge:  $n \cdot G = 0$ .

4.6

Light-cone singularity:

if we calculate  $f_{3/8}(x, \vec{k}_\perp)$  at one-loop,

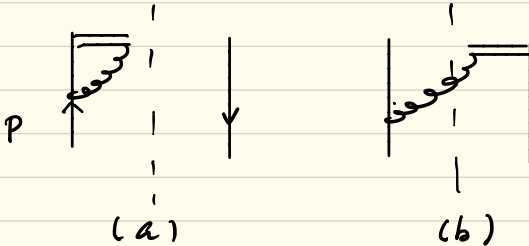

$$f_{3/8}(x, \vec{k}_\perp) \Big|_a \sim \delta(1-x) \delta^2(\vec{k}_\perp) \int_0^1 \frac{dy}{1-y},$$

$\uparrow$  divergent

$$f_{3/8}(x, \vec{k}_\perp) \Big|_b \sim (x, \vec{k}_\perp) \frac{1}{1-x}, \quad x \rightarrow 1$$

collinear PDF

$$\int d^2 k_\perp \left[ f_{3/8} \Big|_a + f_{3/8} \Big|_b \right] = \text{"finite"}$$

The divergence: Light-cone singularity.  
related to gauge links.

4.7

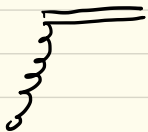

$$\Rightarrow \frac{1}{n \cdot k + i\epsilon} = \frac{1}{k^+ + i\epsilon} \Rightarrow \frac{1}{1-x}$$

$k^+ \rightarrow 0$ , divergent.

One possible way to regularize the divergence:

Gauge link off light-cone:

$$u^\mu = (u^+, u^-, 0, 0) \quad \text{instead of } n^\mu = (0, 1, 0, 0)$$

Def:

$$V_u(\xi, \infty) = P \exp \left\{ -i g_s \int_0^\infty d\lambda u \cdot G(\lambda u + \xi) \right\}$$

$$f(x, k_\perp) = \int \frac{d^3 \tilde{\xi}}{2(2\pi)^3} e^{-i \tilde{\xi} \cdot k}$$

$$\langle h | \bar{\xi}(\xi) V_u^+(\xi, \infty) \delta^+ V_u(0, \infty) f(0) | h \rangle$$

$u^+ \rightarrow 0$ , but finite.

$$f \text{ depends on } u, \quad \xi_u^2 = \frac{4(u \cdot p)^2}{u^2} \approx \frac{2u^-}{u^+} (p^+)^2$$

$f$  depends on the energy of the hadron !!

4.8.

Evolution of TMD PDF:

$$\mu \frac{\partial}{\partial \mu} f(x, k_{\perp}, \mu, \xi_n) = 2 \gamma_F f(x, k_{\perp}, \mu, \xi_n)$$

$\gamma_F$ : Anomalous dimension of the quark field in the axial gauge  $n \cdot G = 0$ .

$$\gamma_F = \frac{3\alpha_s}{4\pi} C_F + O(\alpha_s^2)$$

It is much more simple than DGLAP.

The reason:

$\int d^2 k_{\perp} f(x, k_{\perp})$  has more U.V. divergences, more U.V. subtraction.

$\Rightarrow$

$$\int d^2 k_{\perp} f(x, k_{\perp}) \neq f_{g/p}(x) !!$$

4. P.

The evolution of  $\xi_u$ : Collins-Soper Eq. !!

It takes simple form in  $b$ -space,  $b^\mu = (b^1, b^2)$ .

$$f(x, b, \mu, \xi_u) = \int d^2 k_\perp e^{i \vec{b} \cdot \vec{k}_\perp} f(x, k_\perp, \mu, \xi_u)$$

$$\xi_u \frac{\partial}{\partial \xi_u} f(x, b, \mu, \xi_u) = \left( K(\mu, b) + G(\mu, \xi_u) \right) f(x, b, \mu, \xi_u)$$

$$K(\mu, b) + G(\mu, \xi_u) = - \frac{2s}{\pi} C_F \ln \frac{\xi_u^2 b^2 e^{2\sigma_E - 1}}{4}$$

$$\mu \frac{\partial}{\partial \mu} K = -\sigma_K = -\mu \frac{\partial}{\partial \mu} G$$

$\sigma_K$ : cusp anomalous dimension

$$\sigma_K = \frac{2s}{\pi} 2C_F$$

CS equation  $\Rightarrow$  CSS resummation

Very important !

4.10

Similarly, we can define TMD FF's.

$$h(P_h), \quad P_h^\mu = (0, P_h^-, 0, 0),$$

$$\text{Def: } V_V(\xi, -\infty) = P \exp \left\{ -i g_s \int_{-\infty}^0 d\lambda \, v \cdot G(\lambda v + \xi) \right\},$$

$$V^\mu = (V^+, V^-, 0, 0), \quad V^+ \gg V^-$$

(Kinematics).

TMD FF:

$$\hat{g}(\xi, k_\perp) = \frac{1}{2\xi} \int \frac{d^3 \tilde{\xi}}{(2\pi)^3} e^{-i \tilde{\xi} \cdot k} \frac{1}{N_c} \sum_x \text{Tr}$$

$$\langle 0 | \sigma^+ V_V^+(0) g(0) | h_x \rangle \langle h_x | \bar{g}(\tilde{\xi}) V_V(\tilde{\xi}) | 0 \rangle,$$

$$\text{here: } \tilde{\xi}^\mu = (\xi^+, 0, \vec{\xi}_\perp), \quad k^\mu = (0, \frac{1}{2} P_h^-, -\frac{1}{2} \vec{P}_{h\perp}),$$

$$\hat{g} \text{ depends on } \mu, \quad \xi_V^2 = \frac{4 (v \cdot P_h)^2}{v^2}$$

↑  
expansi..

4.11

Factorization: Breit frame

$$h_A(P) + \delta^+(z) \longrightarrow h_B(P_h) + X$$

$$z^2 = -Q^2 \rightarrow -\infty, \quad P_{h\perp}^2/Q^2 \ll 1$$

Def: 
$$X = \frac{-z^2}{2P \cdot z} = \frac{Q^2}{2P \cdot z} = -\frac{z^+}{P^+}, \quad X_B.$$

$$z = \frac{P \cdot P_h}{P \cdot z} = \frac{P_h^-}{z^-}, \quad P_{h\perp}^\mu = g_\perp^{\mu\nu} P_{h\nu}$$

The hadronic tensor:

$$W^{\mu\nu}(P, z, P_h) = \frac{1}{z} \int \frac{d^4k}{(2\pi)^4} e^{i z \cdot k} \sum_X$$

$$\langle h_A | J^\mu(x) | h_B X \rangle \langle X h_B | J^\nu(0) | h_A \rangle$$

$$= -\frac{1}{2} g_\perp^{\mu\nu} F(x, z, P_{h\perp}, Q)$$

+ "Power suppressed"

$g_\perp^{\mu\nu} = g^{\mu\nu} - n^\mu l^\nu - n^\nu l^\mu$ , can be defined covariantly.



4.12

Factorization at tree-level:

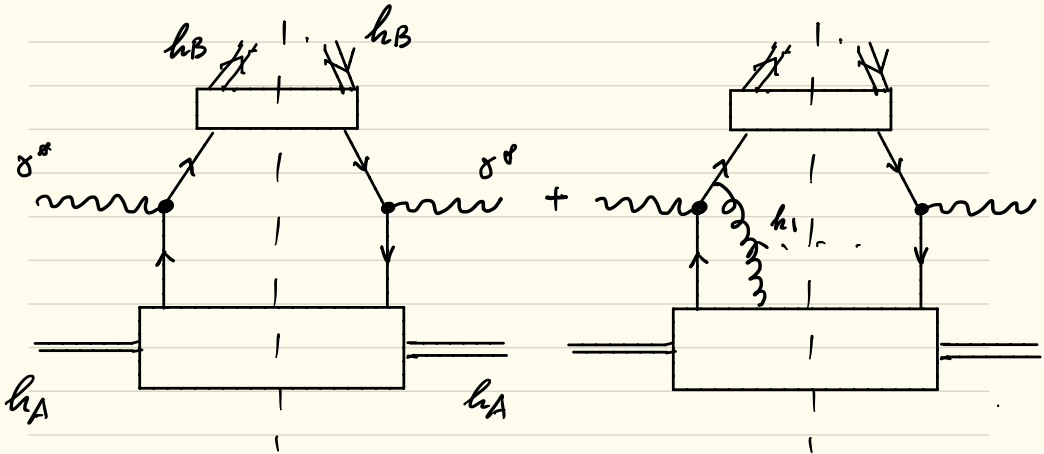

A factor:

$$\frac{i}{-k_1^+ - i\epsilon} (-i g_s n^{\mu} T^a)$$

Summing all  $G^+$  gluon  
from the bottom

$\Rightarrow$  gauge link  $V_n$ ,

replace  $k_1^+ \rightarrow u \cdot k$  !!

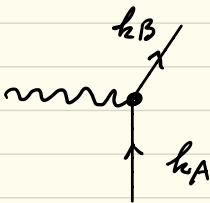

4.13.

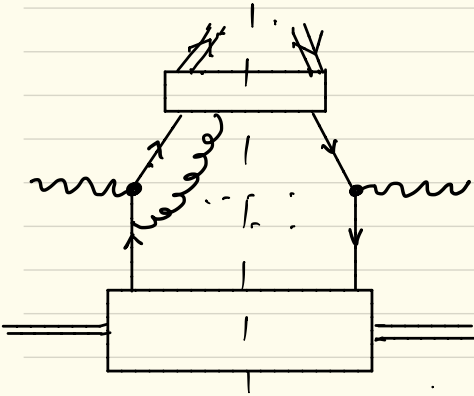

summed  
with the gauge  
link  $V_V$

Important: to calculate the middle part

In the middle  
part:

$$k_A^\mu = (k_A^+, 0, 0, 0)$$

$$k_B^\mu = (0, k_B^-, 0, 0)$$



on-shell amplitudes

$\Rightarrow$  gauge invariant

$k_{A\perp}, k_{B\perp}$  only included in the momentum  
conservation.

4.14

⇒ Tree-level factorization:

$$F(x, \bar{z}, P_{h\perp}, Q) = \int d^2 k_{A\perp} d^2 k_{B\perp} \delta^2(\bar{z} \vec{k}_{B\perp} + \vec{k}_{A\perp} - \vec{P}_{h\perp})$$
$$f(x, k_{A\perp}) \hat{g}(\bar{z}, k_{B\perp})$$

But this is not correct beyond tree-level.

At one-loop:

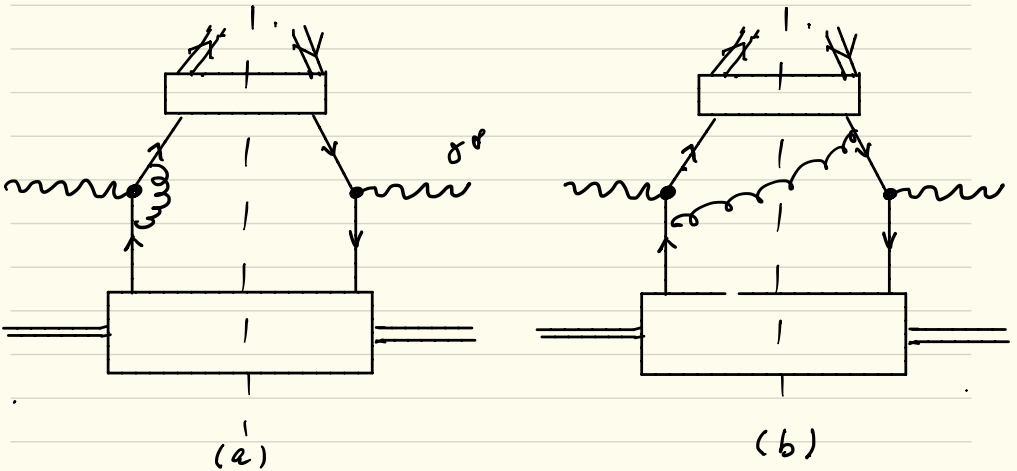

Because the sum of final states is incomplete,  
KLN theorem does not apply !!

4.15.

Following the analysis of DIS, one finds:

- The gluon collinear to  $k_A$  or  $k_B$ ,  
with the momentum  $k^\mu \sim (1, \lambda^2, \lambda, \lambda)$   
is factorized into TMD PDF of  $k_A$ .
- The gluon collinear to  $k_B$  or  $k_A$ ,  
with the momentum  $k^\mu \sim (\lambda^2, 1, \lambda, \lambda)$   
is factorized into TMD FF of  $k_B$ .

The contribution from the soft gluon  
with  $k^\mu \sim (\lambda, \lambda, \lambda, \lambda)$  is still there and  
divergent, because no KLN.

The soft gluon Fig. (a) and (b) can be factorized

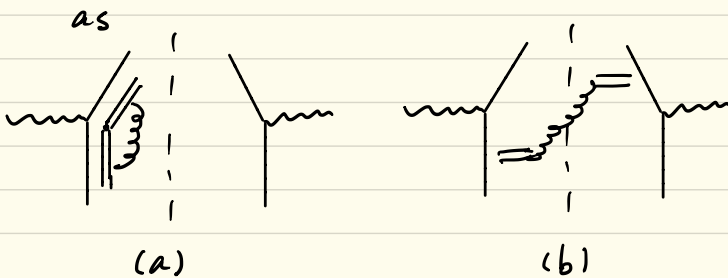

4.16

There are also extra soft-gluon-contributions in TMD PDF and TMD FF.

The soft factor:  $\rho^2 = \frac{4(u \cdot v)^2}{u^2 v^2}$

$$S(\vec{k}_\perp, \mu, \rho) = \frac{1}{N_c} \text{Tr} \langle 0 | V_V^+(\vec{k}_\perp, -\infty) V_u^+(\infty, \vec{k}_\perp) V_u(0, \infty) V_V(0, -\infty) | 0 \rangle$$

Diagram representation:

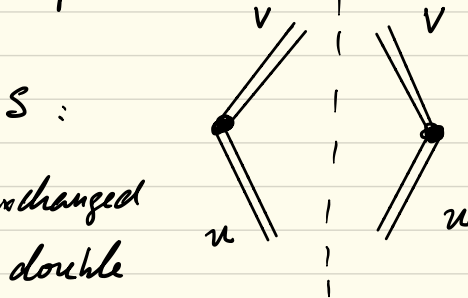

gluons exchanged between double lines.

Def:

$$\tilde{S}(\vec{k}_\perp, \mu, \rho) = \int \frac{d^2 \xi_\perp}{(2\pi)^2} e^{i \vec{k}_\perp \cdot \vec{k}_\perp} [S(\vec{k}_\perp, \mu, \rho)]^{-1}$$

(-1)!!

4.17.

The correct factorization beyond tree-level:

$$F(x, z, P_{A_1}, Q) = H(Q, \mu, \xi_u, \xi_v) \int d^2 k_{A_1} d^2 k_{B_1} d^2 k_{\perp} \delta^2(\vec{z} k_{B_1} + \vec{k}_{A_1} + \vec{k}_{\perp} - \vec{P}_{A_1})$$
$$f(x, k_{A_1}, \mu, \xi_u) \hat{\mathcal{G}}(z, k_{B_1}, \mu, \xi_v) \tilde{\mathcal{S}}(k_{\perp}, \mu, \rho)$$

$H$ : Perturbative coefficients, finite.

$$H = 1 + O(\alpha_s)$$

In  $b$ -space:

$$F(x, z, \vec{b}, Q) = H(Q, \mu, \xi_u, \xi_v) S^{-1}(b, \mu, \rho)$$

$$f(x, b, \mu, \xi_u) \hat{\mathcal{G}}(z, b, \mu, \xi_v)$$

4.18.

## Collinear PDF's vs TMD PDF's

Collinear PDF's: longitudinal motion of partons, one-dimension.

TMD PDF's: Three-dimensional motion of partons, more about inner structure.

At leading twist, only 3 PDF's of spin-1/2

$$\int \frac{d\lambda}{2\pi} e^{-i\lambda P^+ x} \langle h(P) | \bar{\psi}(\lambda n) \psi(0) | h(P) \rangle$$
$$= \frac{1}{2N_c} \left[ \sigma^- \psi(x) + \gamma^5 \sigma^- \lambda \psi_L(x) - i \sigma^- \sigma_{\perp}^{\mu} \tilde{S}_{\perp\mu} \psi_T(x) \right]$$

$\lambda$ : helicity of  $h$

+ "-----"  
high twist

$\vec{S}_{\perp}$ : transverse spin of  $h$ ,  $\tilde{S}_{\perp}^{\mu} = \epsilon_{\perp}^{\mu\nu} S_{\perp\nu}$ .

4.1f.

At leading power or twist-2, there are

8 TMD PDF's !! TMD FF's

"TMD Physics"

Strong experimental programs at J-Lab, COMPASS  
and Belle, even BES II

↳ Collins effect



S.1

5. QCD Factorization in  $e^+e^- \rightarrow h + X$

$$e^+e^- \rightarrow \delta^p(\mathcal{E}) \rightarrow h(P) + X$$

$$s^2 > 0, \quad s^2 \gg \Lambda^2, \quad \Lambda \sim \Lambda_{\text{QCD}}$$

Similarly to DIS, we define the hadronic tensor:

$$W^{\mu\nu} = \int d^4x e^{i\mathcal{E}\cdot x} \sum_x \langle 0 | J^\mu(x) | h, x \rangle \langle h, x | J^\nu(0) | 0 \rangle,$$

Taking a frame:

$$p^\mu \approx (p^+, 0, 0, 0), \quad \mathcal{E}^\mu = (\mathcal{E}^+, \mathcal{E}^-, 0, 0)$$

The analysis is very similar to that of DIS, with the difference of jet functions or "black box".

The same power counting (No OPE).

At leading order:

5.2.

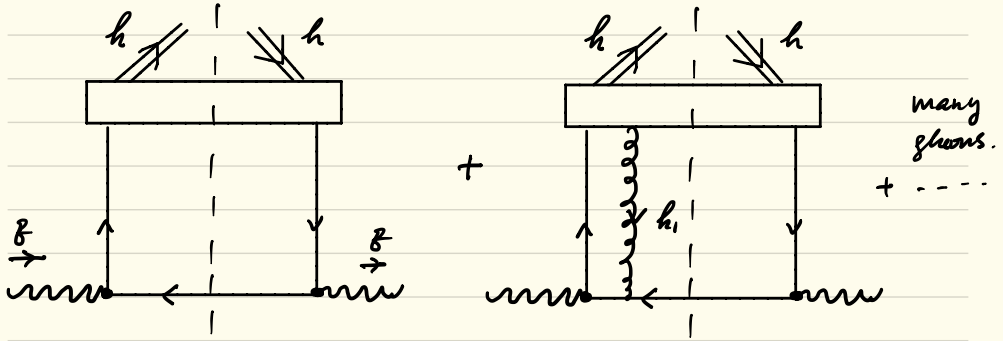

A factor:  $\frac{-i}{-k_i^+ + i\epsilon} (-ig_s \gamma^P)$

The sum of exchanges of gluons can be done with gauge links  $V(x, \infty)$ . This leads to the definition of parton Fragmentation Functions (FF's).

Quark FF:

$$D_{h/q}(\frac{z}{\bar{z}}) = \frac{z}{4\pi} \int d\lambda e^{-i\lambda k^+} \frac{1}{2N_c} \sum_X \text{Tr} \left( \gamma^+ \langle 0 | V^+(0, \infty) \bar{q}(0) | h(P), X \rangle \langle X, h(P) | \bar{q}(\lambda n) V(\lambda n, \infty) | 0 \rangle \right),$$

$$k^+ = \frac{P^+}{z},$$

5.3

it describes that a quark with the momentum  $k^+$  fragments into a hadron with the momentum  $z k^+ = P^+$ .

$|z| \leq 1$ ,  $z > 0$  for quark FF,

$z < 0$  for anti-quark FF.

The gluon FF:

$$D_{h/g}(z) = - \frac{z}{4\pi (N_c^2 - 1) k^+} \int d\lambda e^{-i\lambda k^+} \langle 0 | G^{+\mu}(0) \tilde{V}^{+(0,\infty)} | h(P), x \rangle \langle x, h(P) | \tilde{V}(\lambda u, \infty) G^+_{\mu}(\lambda u) | 0 \rangle.$$

The FF' also depend on  $\mu$ . Their evolutions are in the form of DGLAP. The leading order of evolutions are the same as those of PDF.

The differences appear at two-loop.

5.4.

Statement of QCD factorization:

$$\frac{d\sigma(e^+e^- \rightarrow h+x)}{dz} = \sum_a \int \frac{d\xi}{\xi} H_a\left(\frac{z}{\xi}, Q^2, \mu^2\right) D_{h/a}(\xi, \mu^2) \cdot \left\{ 1 + O\left(\frac{\Lambda^2}{Q^2}\right) \right\}$$

$$\approx \sum_{\xi} \sigma(e^+e^- \rightarrow \xi\bar{\xi}) \left( D_{h/\xi}(z) + D_{h/\bar{\xi}}(z) \right)$$

$z$ : Energy fraction.  $\left\{ 1 + O(\alpha_s) + O\left(\frac{\Lambda^2}{Q^2}\right) \right\}$

$$z = \frac{2Eh}{Q}, \quad Q^2 = z^2.$$

$H_a$ : perturbative coefficient functions, finite!!

Universality of FF's ?

PT-symmetry does not apply,

$$PT |h, x\rangle_{out} = |h, x\rangle_{in} \neq |h, x\rangle_{out}.$$

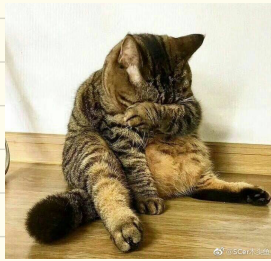

6.1

6. ....

