



Prospect of multi-Baryon Hadronic-Molecule / Cluster with Strangeness

- via the detailed study of the kaonic nucleus -

- 24 / 09 / 2024 -

M. Iwasaki / RIKEN



FB23

THE 23rd INTERNATIONAL CONFERENCE ON
FEW-BODY PROBLEMS IN PHYSICS (FB23)
Sept. 22 -27, 2024 • Beijing, China

Host Institute of High Energy Physics, Chinese Academy of Sciences Institute for Advanced Study, Tsinghua University University of Chinese Academy of Sciences
China Center of Advanced Science and Technology Institute of Theoretical Physics, Chinese Academy of Sciences South China Normal University
Co-host Chinese Physical Society (CPS) High Energy Physics Branch of CPS

2

$\bar{K}N$ interaction study via Kaonic atom

2

Succeeded in Kaonic Hydrogen x-ray Measurement

KpX: obtained X-ray spectrum

Kp experiment at KEK in 1997:

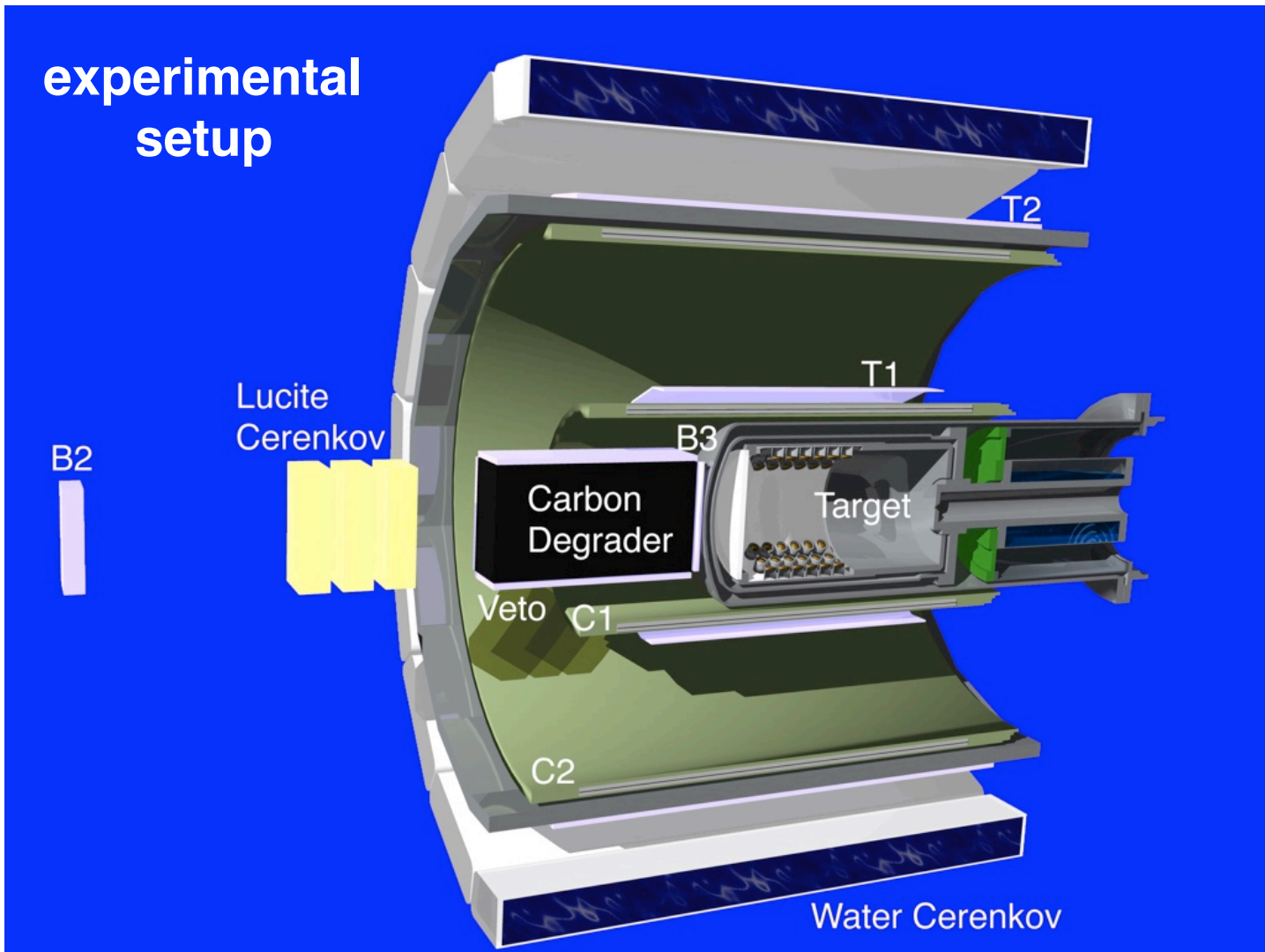
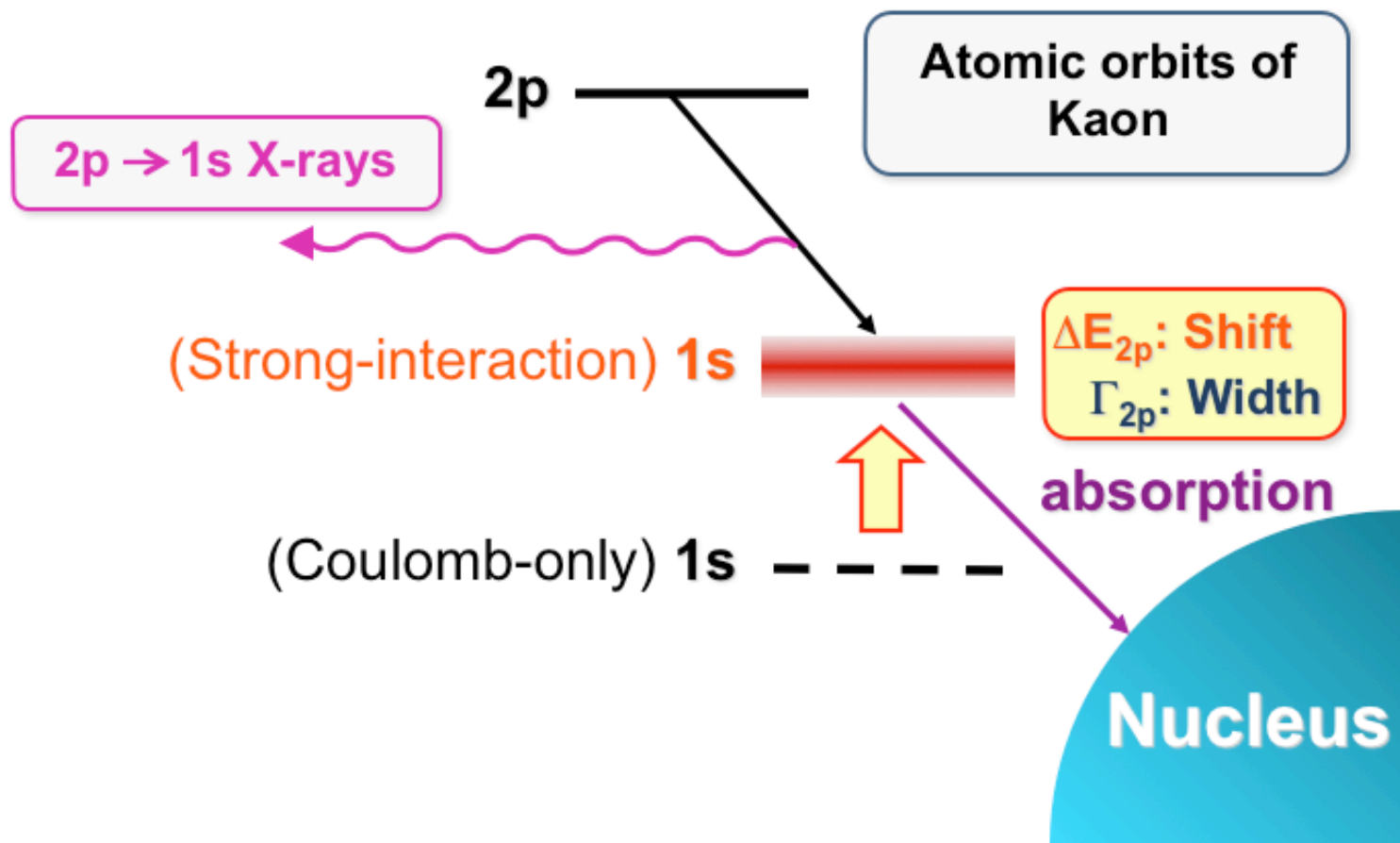

The European Physical Journal C $\Lambda(1405)$

Volume 15 · Number 1-4 · 2000

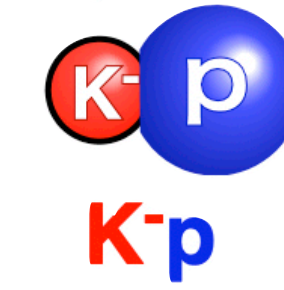

THE $\Lambda(1405)$

Revised March 1998 by R.H. Dalitz, Oxford University

.....
 From the measurement of $2p - 1s$ x rays from kaonic-hydrogen, the energy-level shift ΔE and width Γ of its $1s$ state can give us two further constraints on the $(\bar{S}\pi, NK)$ system, at an energy roughly midway between those from the low-energy hydrogen bubble chamber studies and those from $qR(\Sigma\pi)$ observations below pK^- threshold. IWASAKI 97 have reported the first convincing observation of this x ray, with a good initial estimate:

$$\Delta E - i\Gamma/2 = (-323 \pm 63 \pm 11) - i(204 \pm 104 \pm 50) \text{ eV. (2)}$$

the errors here encompass about half of the predictions made following various analyses and/or models for the in-flight K^-p and sub-threshold $qR(\Sigma\pi)$ data. Better measurements will be needed to discriminate between the analyses and predictions., perhaps from the DAΦNE storage ring at Frascati, information vital for our quantitative understanding of the $(\bar{S}\pi, NK)$ system in this region.

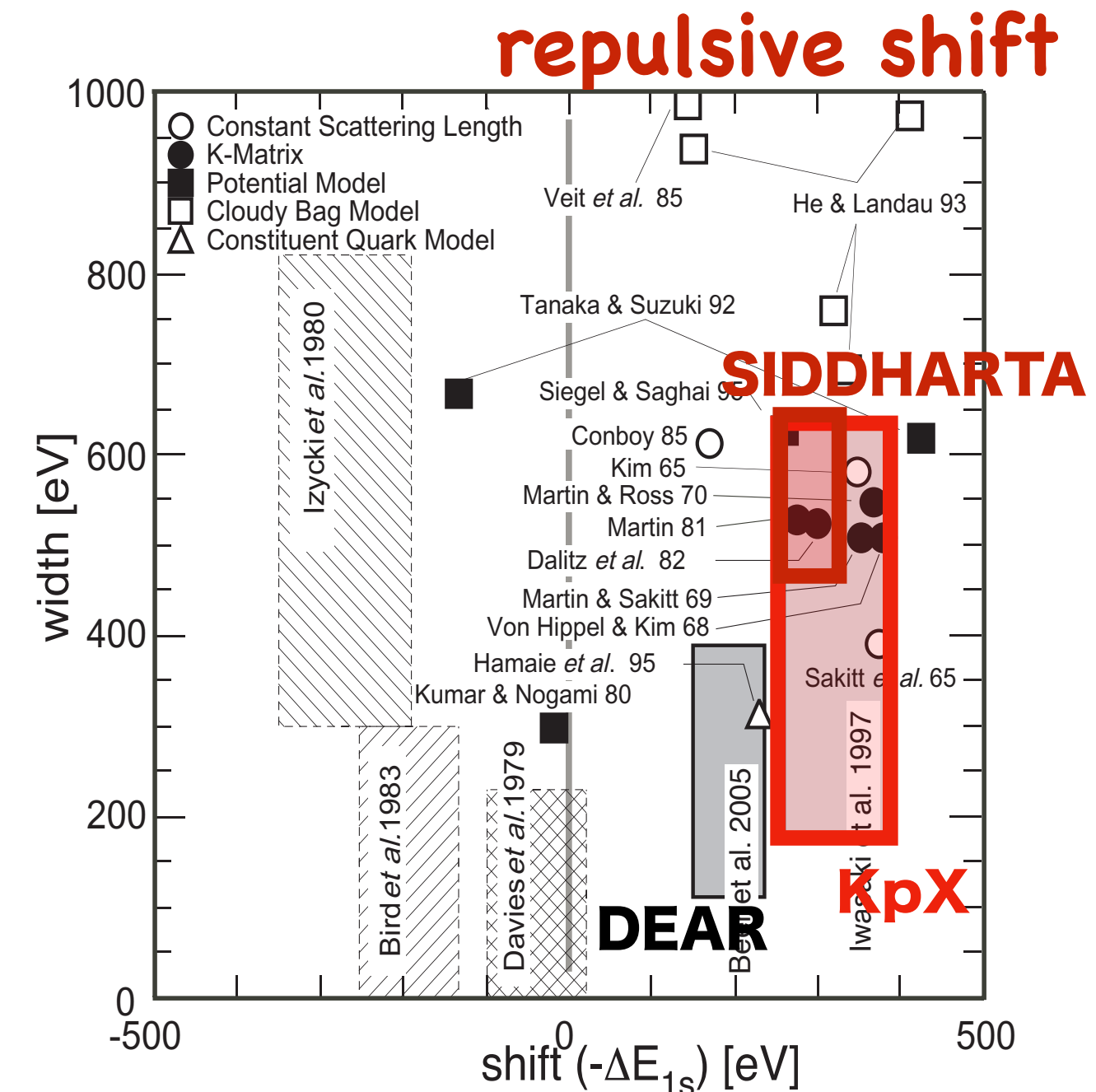
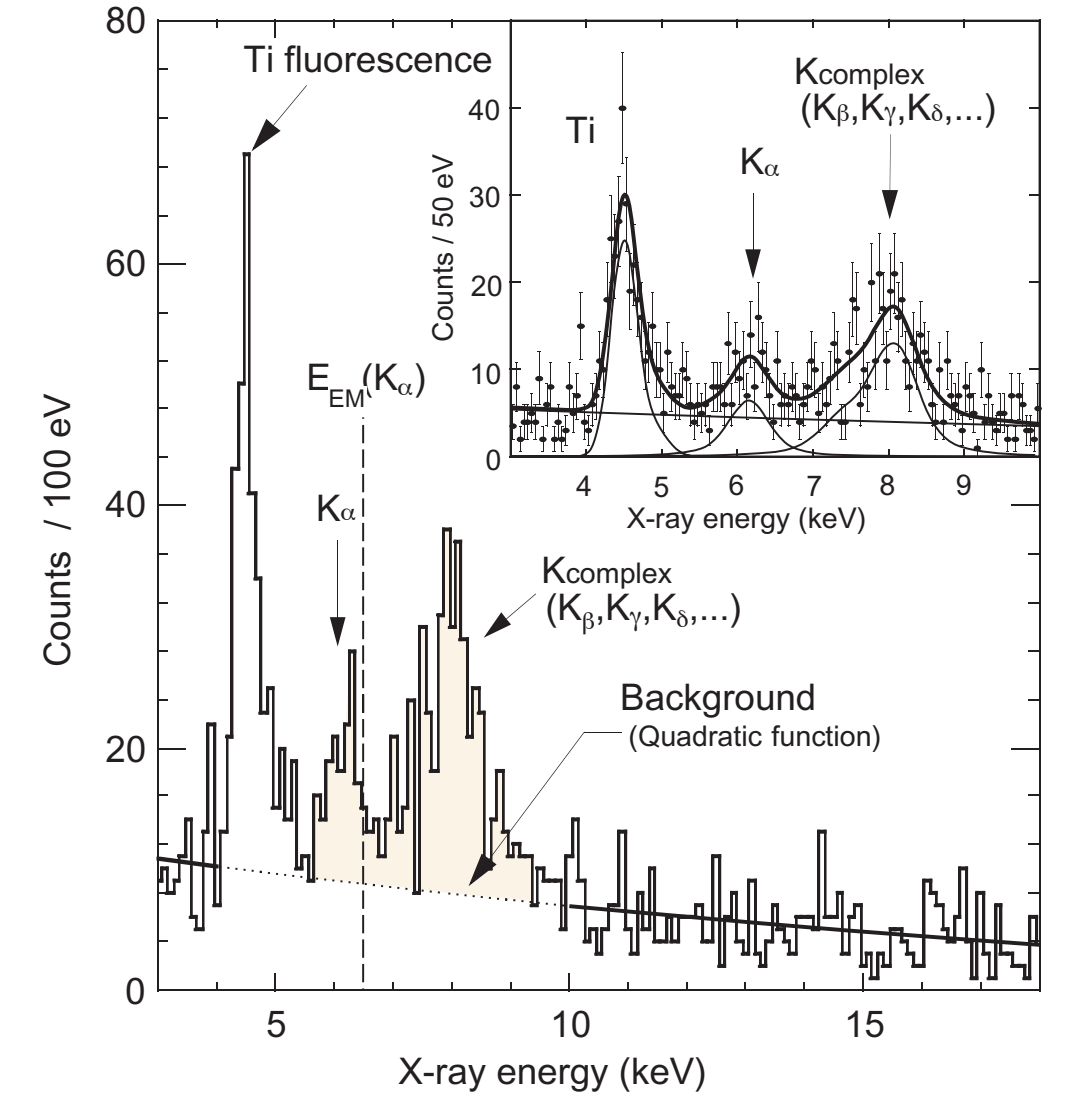

What's next in physics?

Observed Shift was **REPULSIVE!**

Is $\bar{K}N$ interaction repulsive?

Let's study how atomic level shifts depending on $\bar{K}N$ interaction.

Coulomb + $\bar{K}N$ interaction

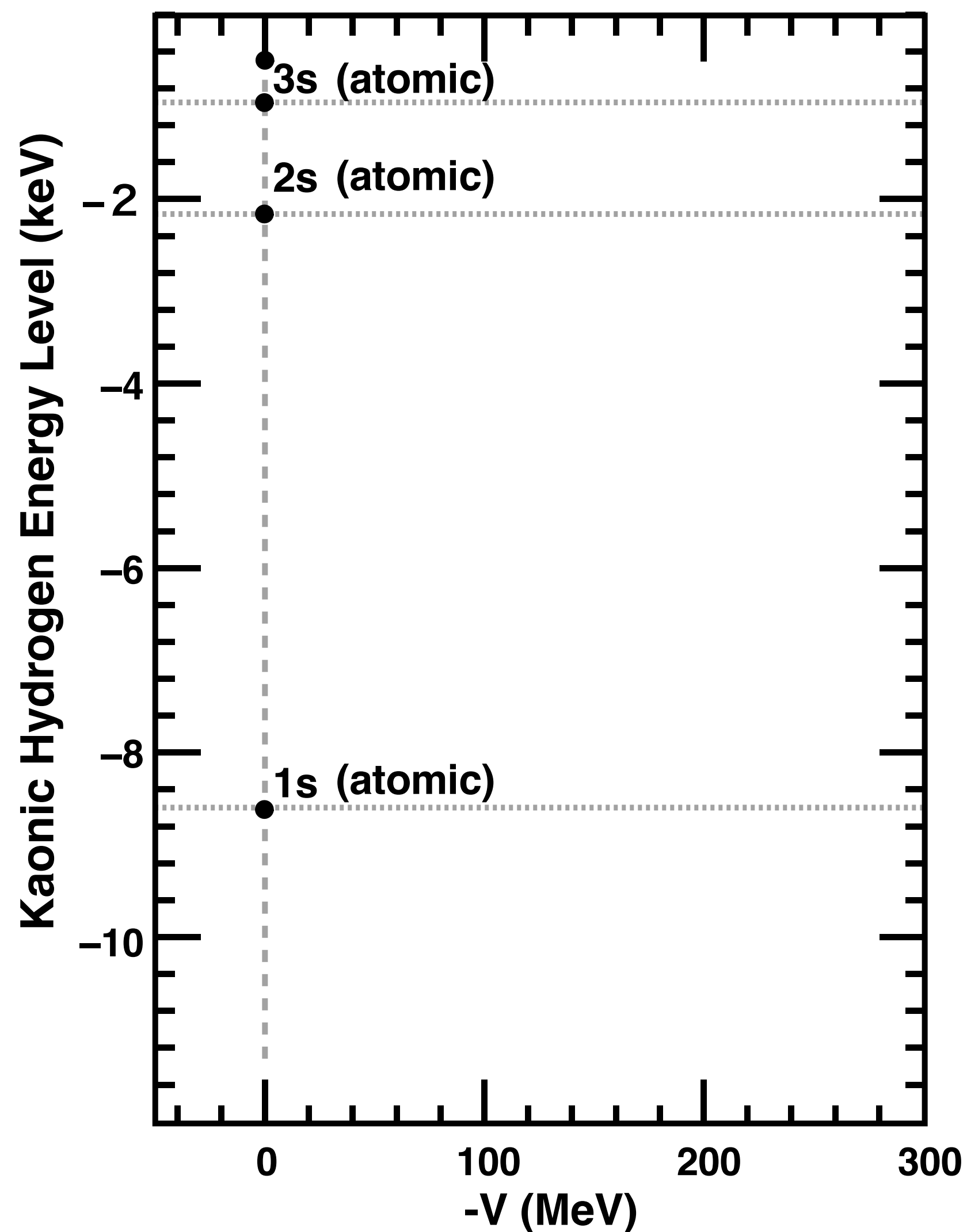

Without $\bar{K}N$ interaction
($V_{\bar{K}N} = 0, W_{\bar{K}N} = 0$), Coulomb potential
forms K^-p atomic levels.

Observed Shift was **REPULSIVE!**

Is $\bar{K}N$ interaction repulsive?

Let's study how atomic level shifts depending on $\bar{K}N$ interaction.

Coulomb + $\bar{K}N$ interaction

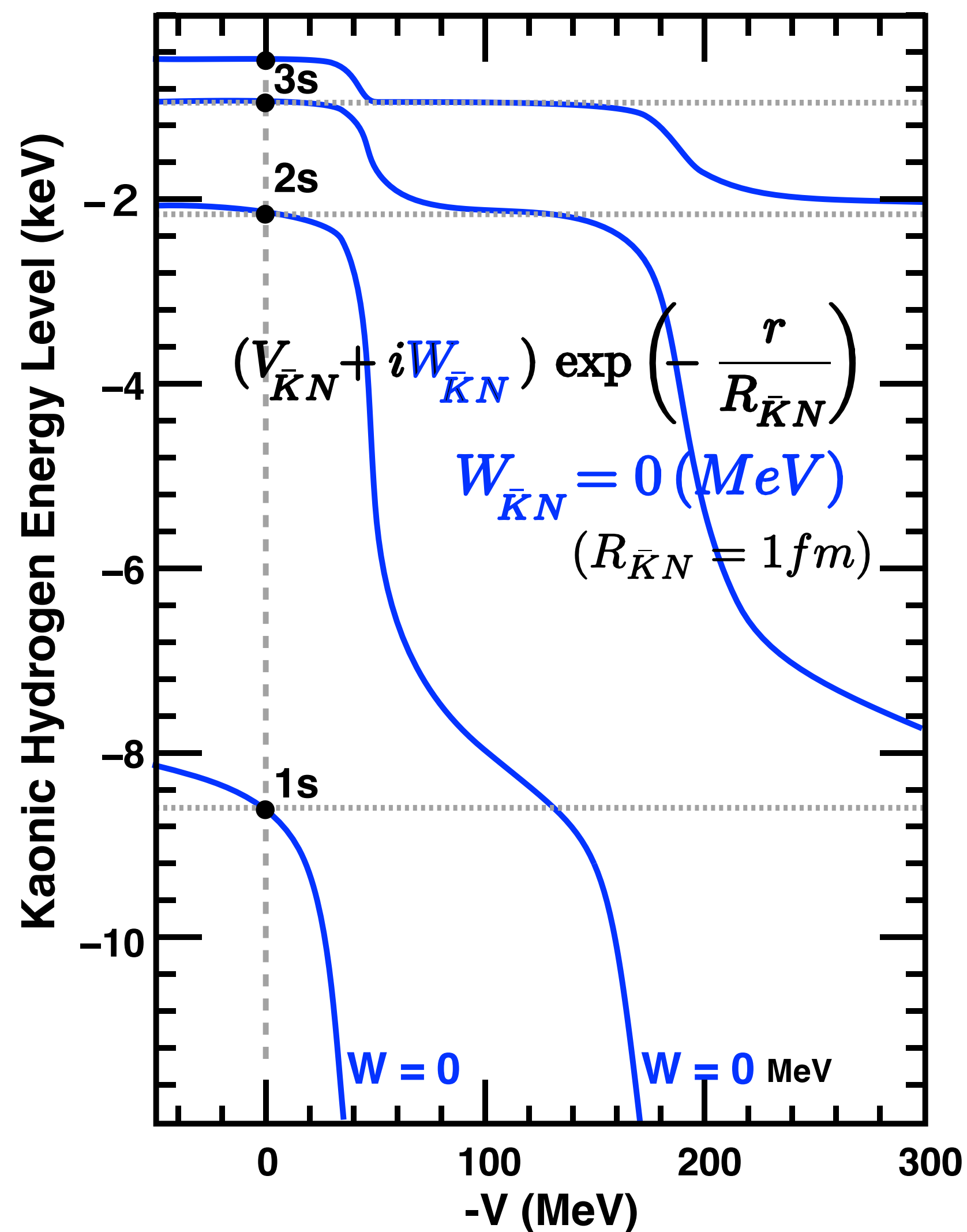

Without $\bar{K}N$ interaction

($V_{\bar{K}N} = 0, W_{\bar{K}N} = 0$), Coulomb potential forms K^-p atomic levels.

Each atomic level shifts downward as a function of $-V_{\bar{K}N}$ (at $W_{\bar{K}N} = 0$) in a step-like function, and atomic $1s$ change its nature to be a nuclear ground state.

Observed Shift was **REPULSIVE!**

Is $\bar{K}N$ interaction repulsive?

Let's study how atomic level shifts depending on $\bar{K}N$ interaction.

Coulomb + $\bar{K}N$ interaction

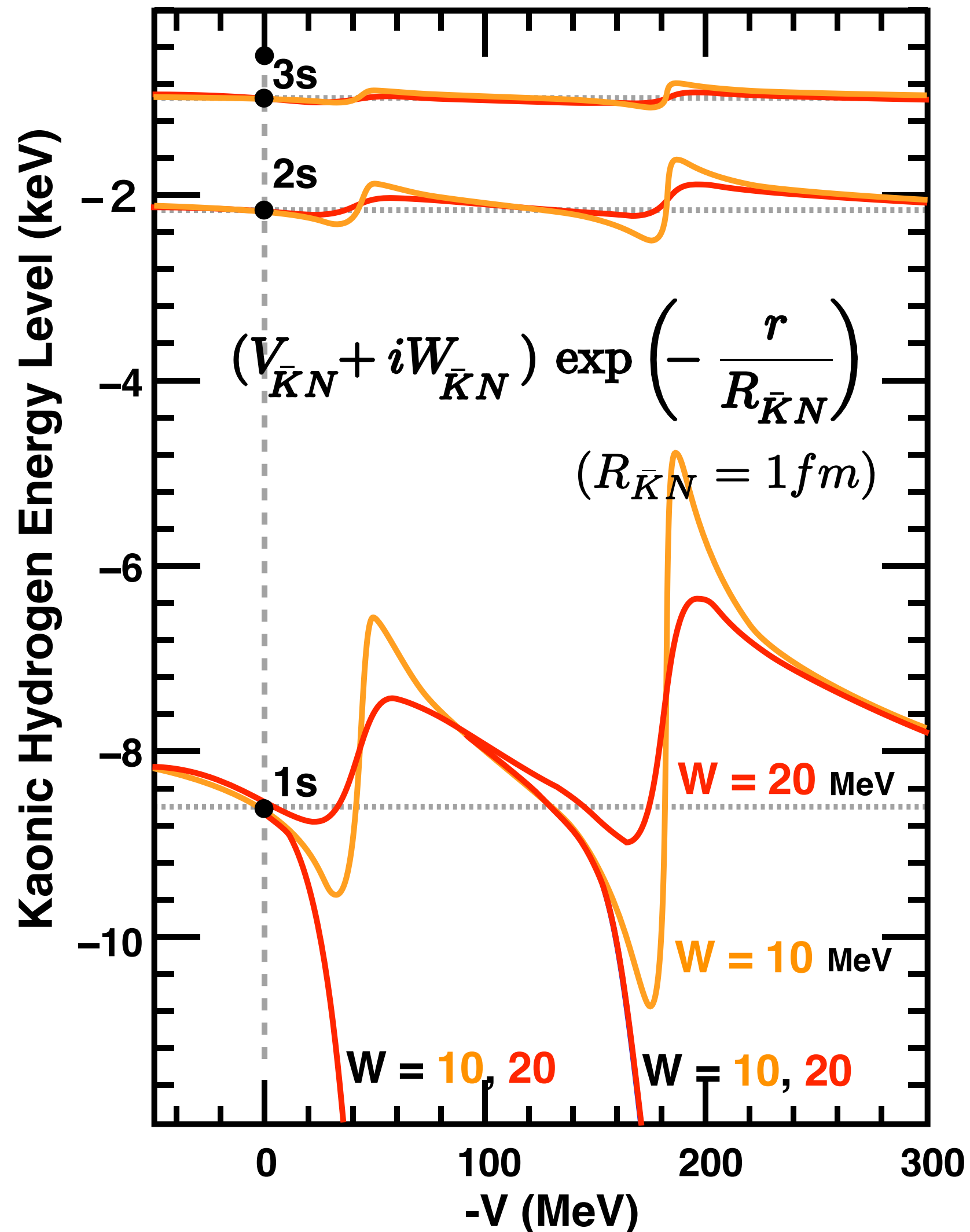

*Without $\bar{K}N$ interaction
 $(V_{\bar{K}N} = 0, W_{\bar{K}N} = 0)$, Coulomb potential
 forms K^-p atomic levels.*

*Each atomic level shifts downward as a function of
 $-V_{\bar{K}N}$ (at $W_{\bar{K}N} = 0$) in a step-like function, and atomic
 1s change its nature to be a nuclear ground state.*

*When switching on the absorption part $W_{\bar{K}N}$,
 a level crossing happens and connects to
 another level.*

*As a result, a wiggling pattern appears in energy levels
 (red lines), and the nuclear bound state is branched and
 separated from the atomic ground state.*

Observed Shift was **REPULSIVE!**

Is $\bar{K}N$ interaction repulsive?

Coulomb + $\bar{K}N$ interaction

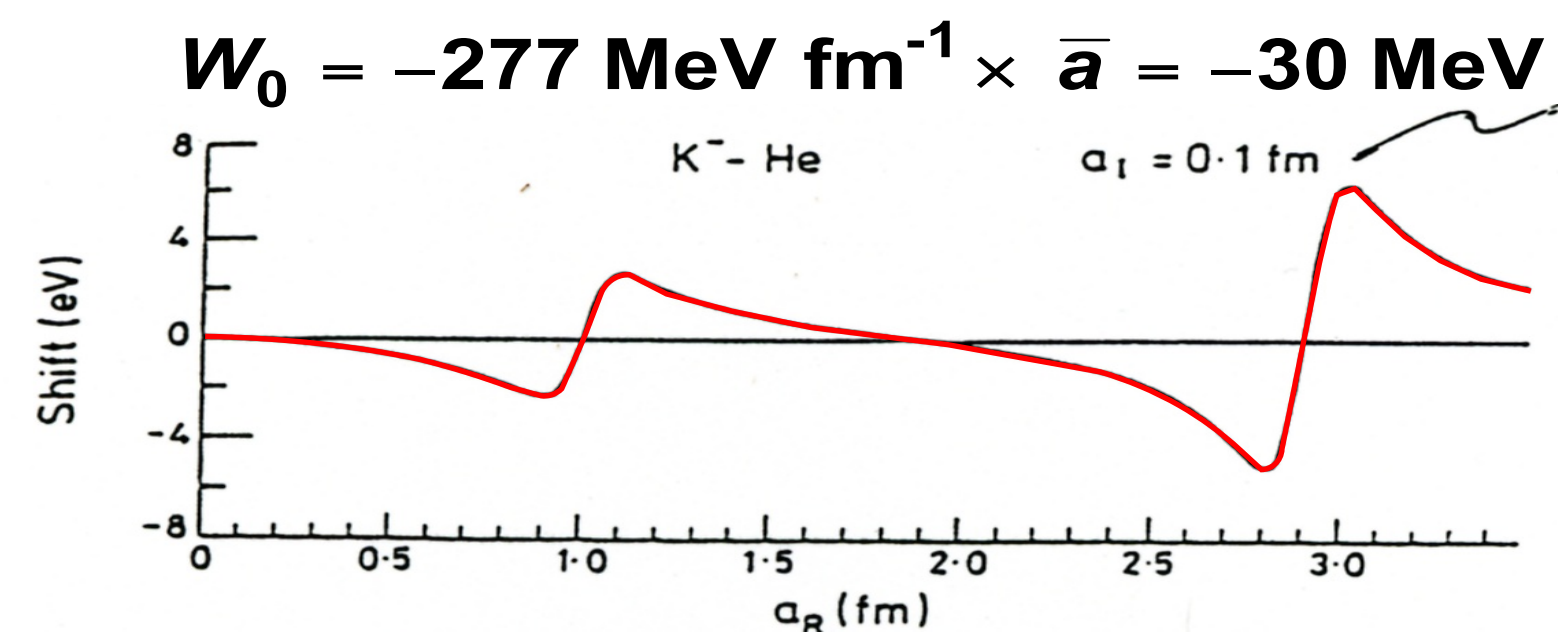
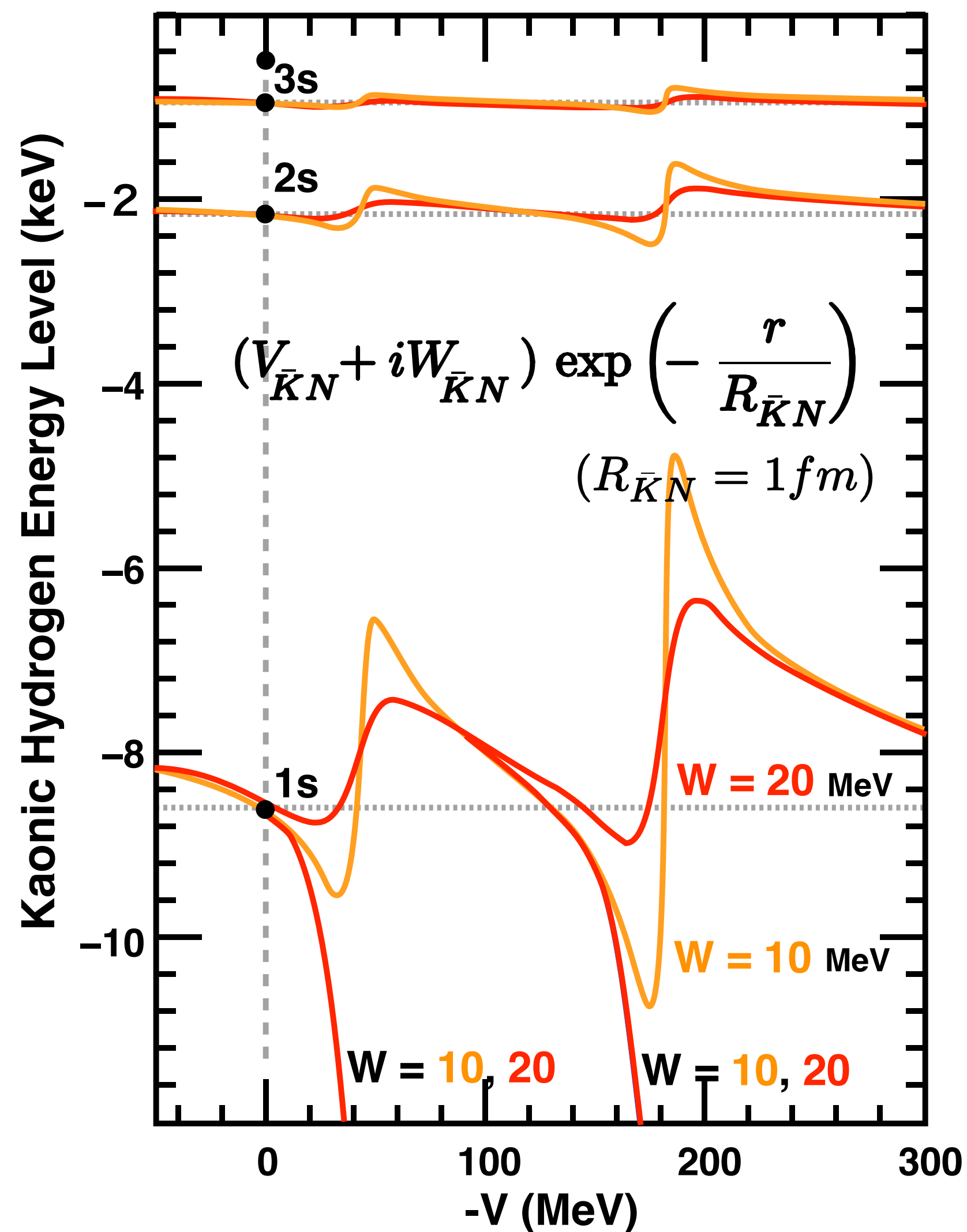

Theoretical calculations for realistic $\bar{K}N$ interaction

R. Seki, Phys. Rev. C5 (1972) 1196

S. Baird et al., Nucl. Phys. A392 (1983) 297

C.J. Batty, Nucl. Phys. A508 (1990) 89c

Observed Shift was **REPULSIVE!**

Is $\bar{K}N$ interaction repulsive?

Coulomb + $\bar{K}N$ interaction

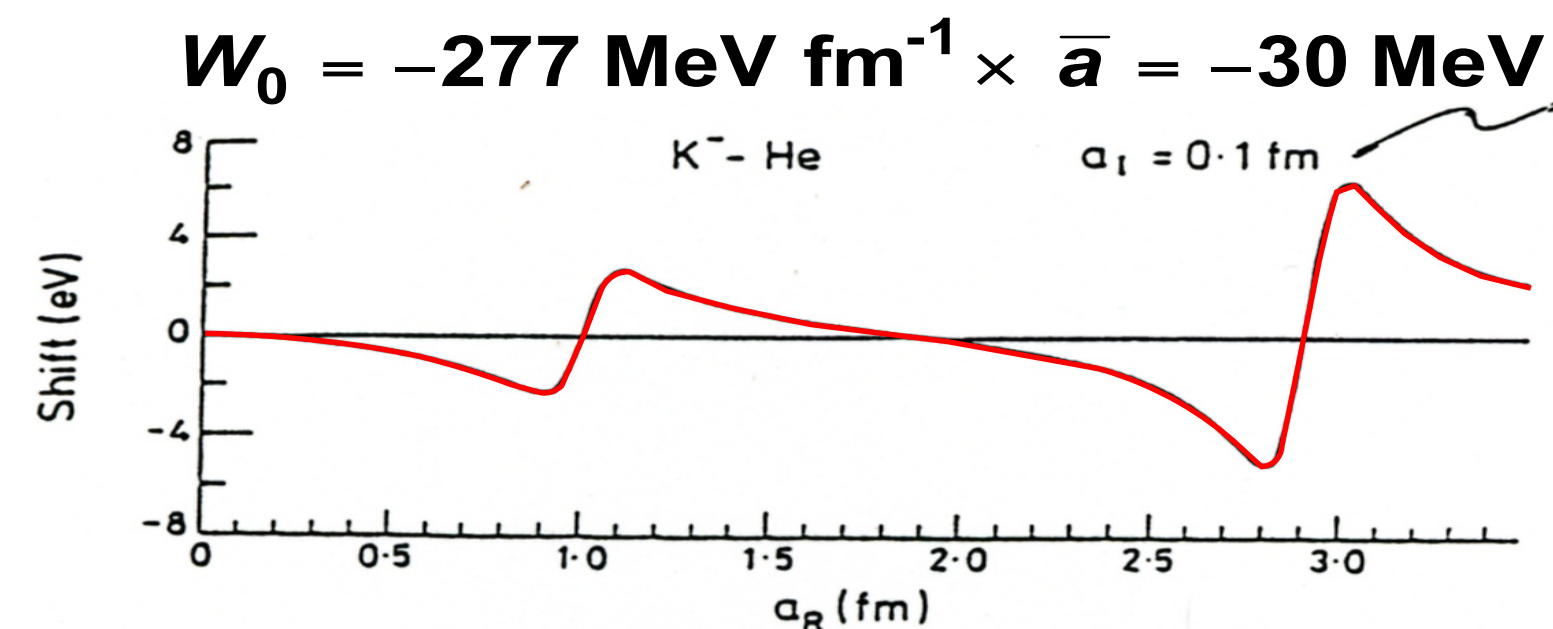
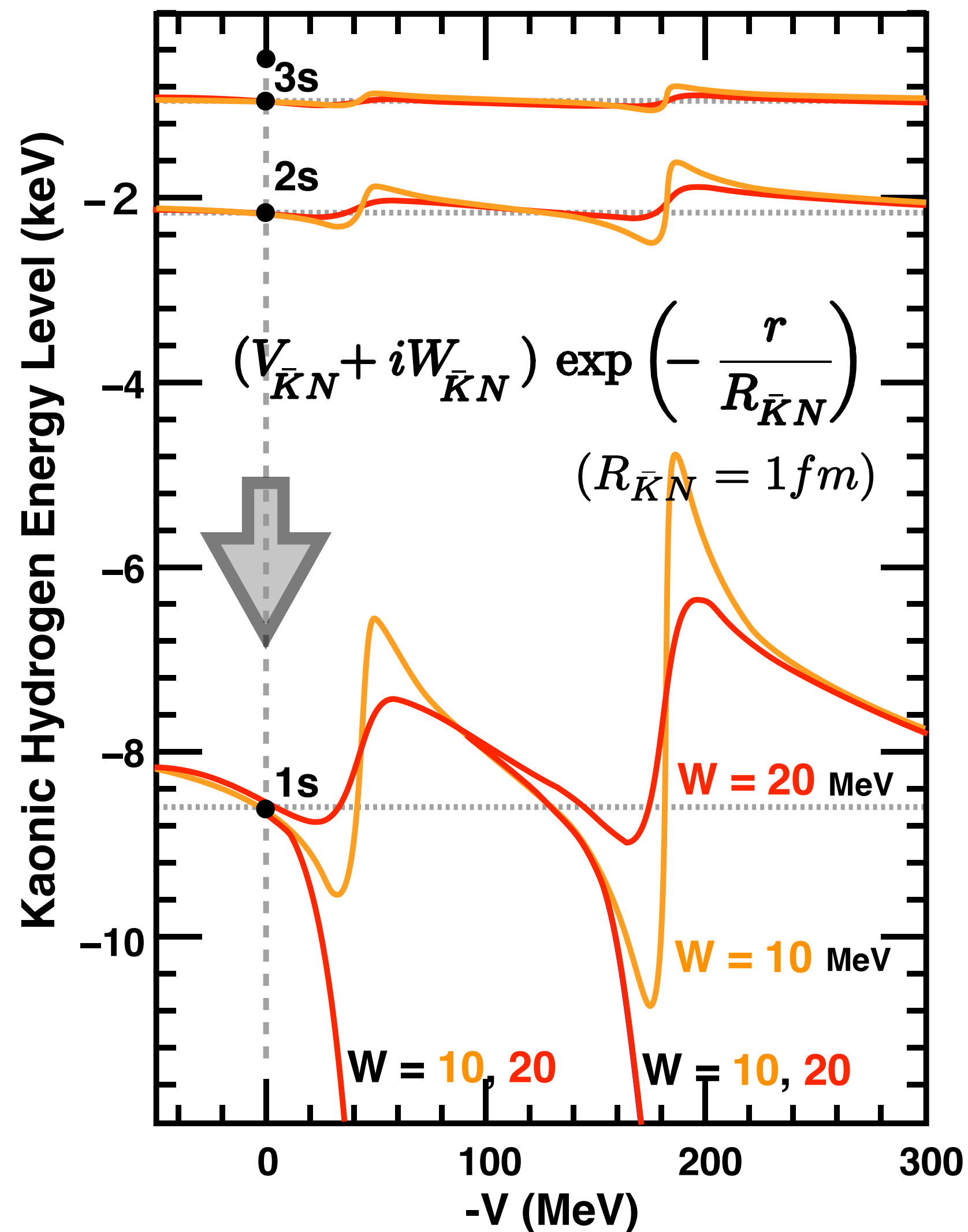

Theoretical calculations for realistic $\bar{K}N$ interaction

R. Seki, Phys. Rev. C5 (1972) 1196

S. Baird et al., Nucl. Phys. A392 (1983) 297

C.J. Batty, Nucl. Phys. A508 (1990) 89c

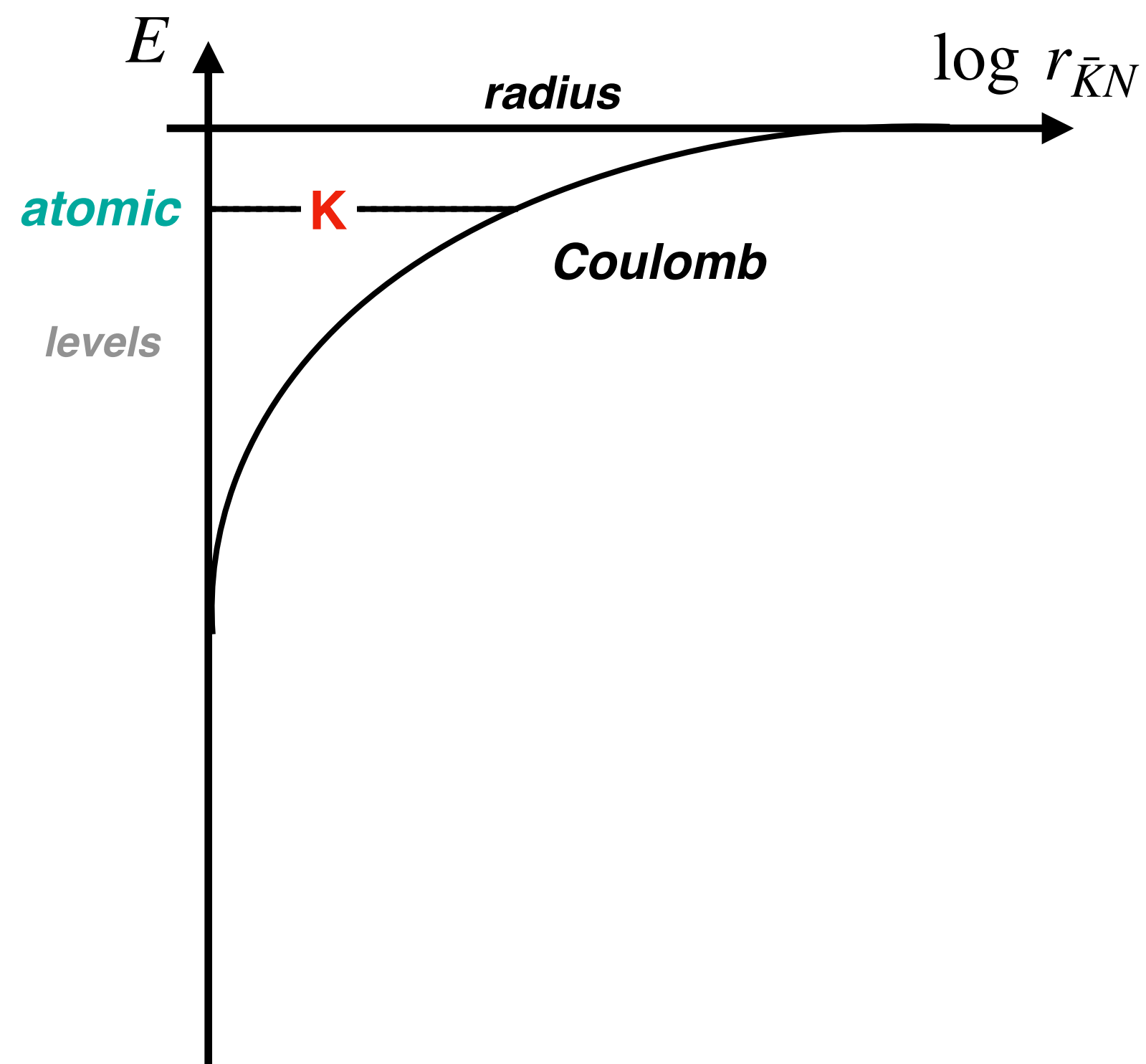

Illustrative Animation

Observed Shift was **REPULSIVE!**

Is $\bar{K}N$ interaction repulsive?

Coulomb + $\bar{K}N$ interaction

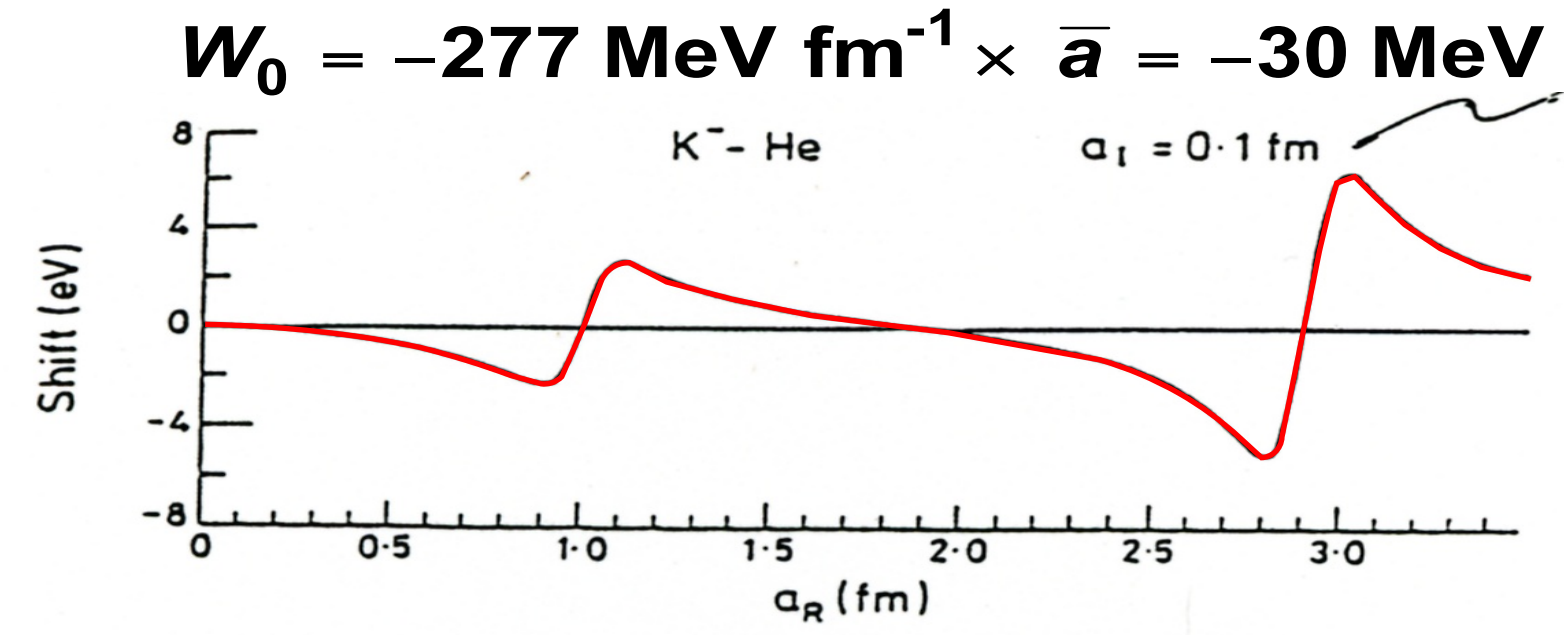
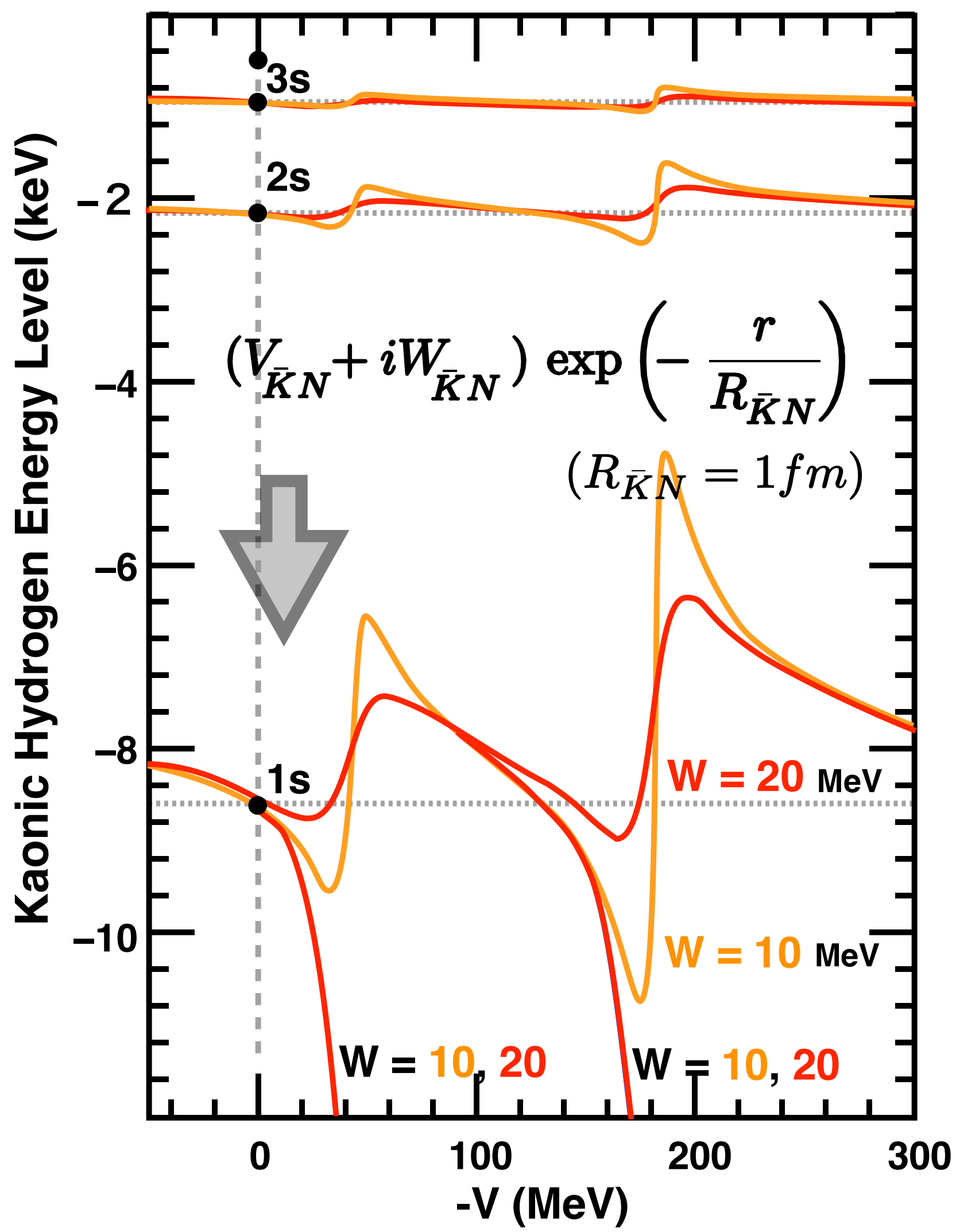

Theoretical calculations for realistic $\bar{K}N$ interaction

- R. Seki, Phys. Rev. C5 (1972) 1196
- S. Baird et al., Nucl. Phys. A392 (1983) 297
- C.J. Batty, Nucl. Phys. A508 (1990) 89c

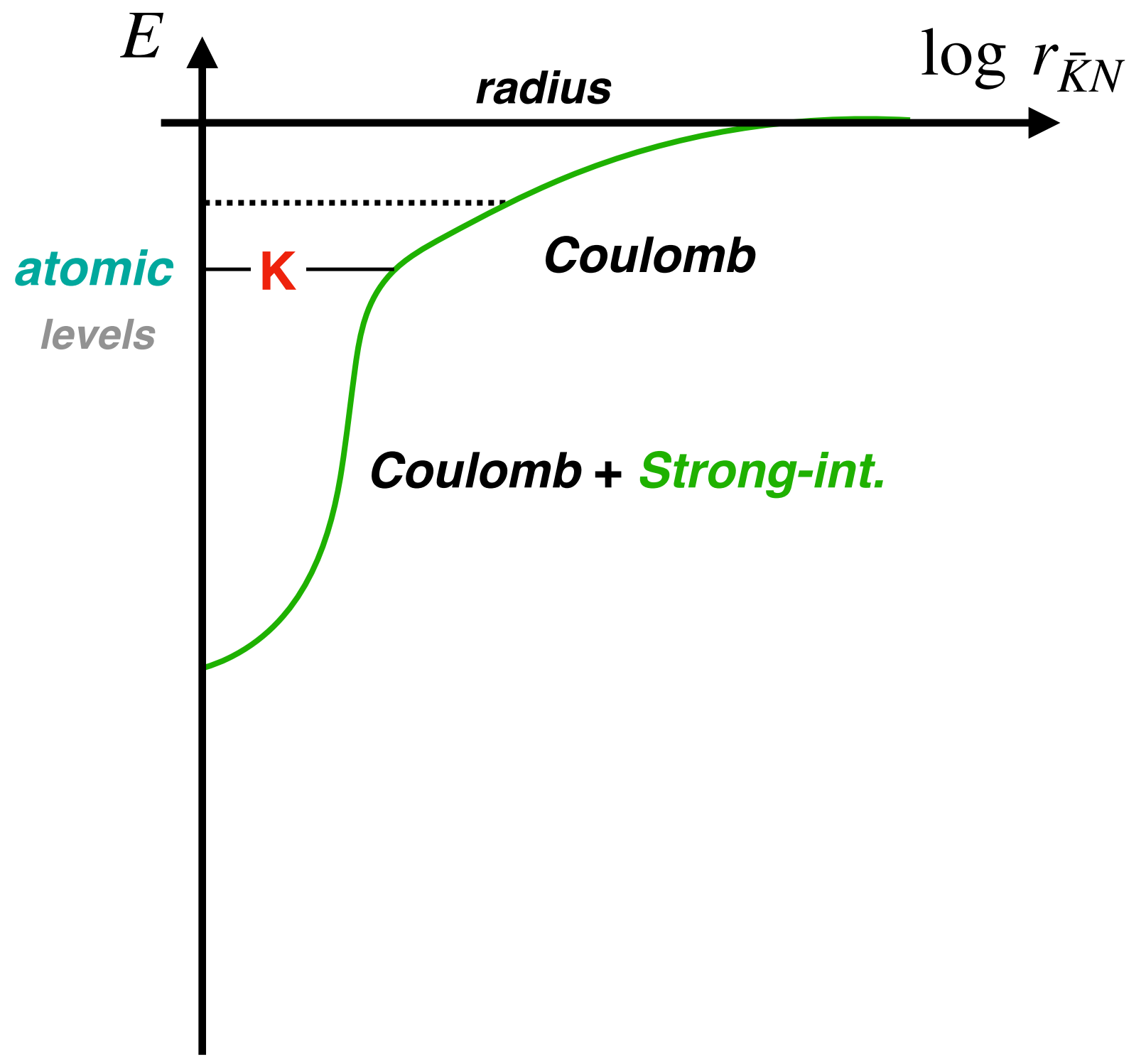

Illustrative Animation

Observed Shift was **REPULSIVE!**

Is $\bar{K}N$ interaction repulsive?

Coulomb + $\bar{K}N$ interaction

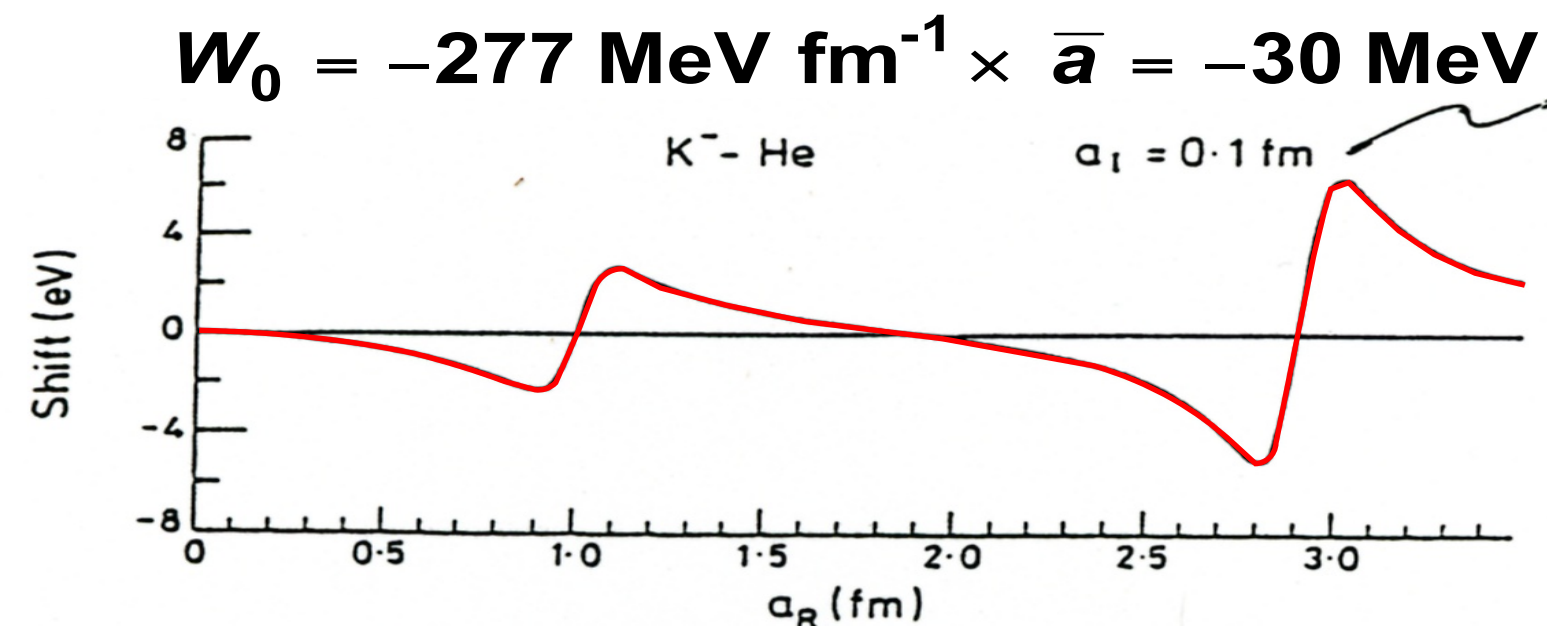
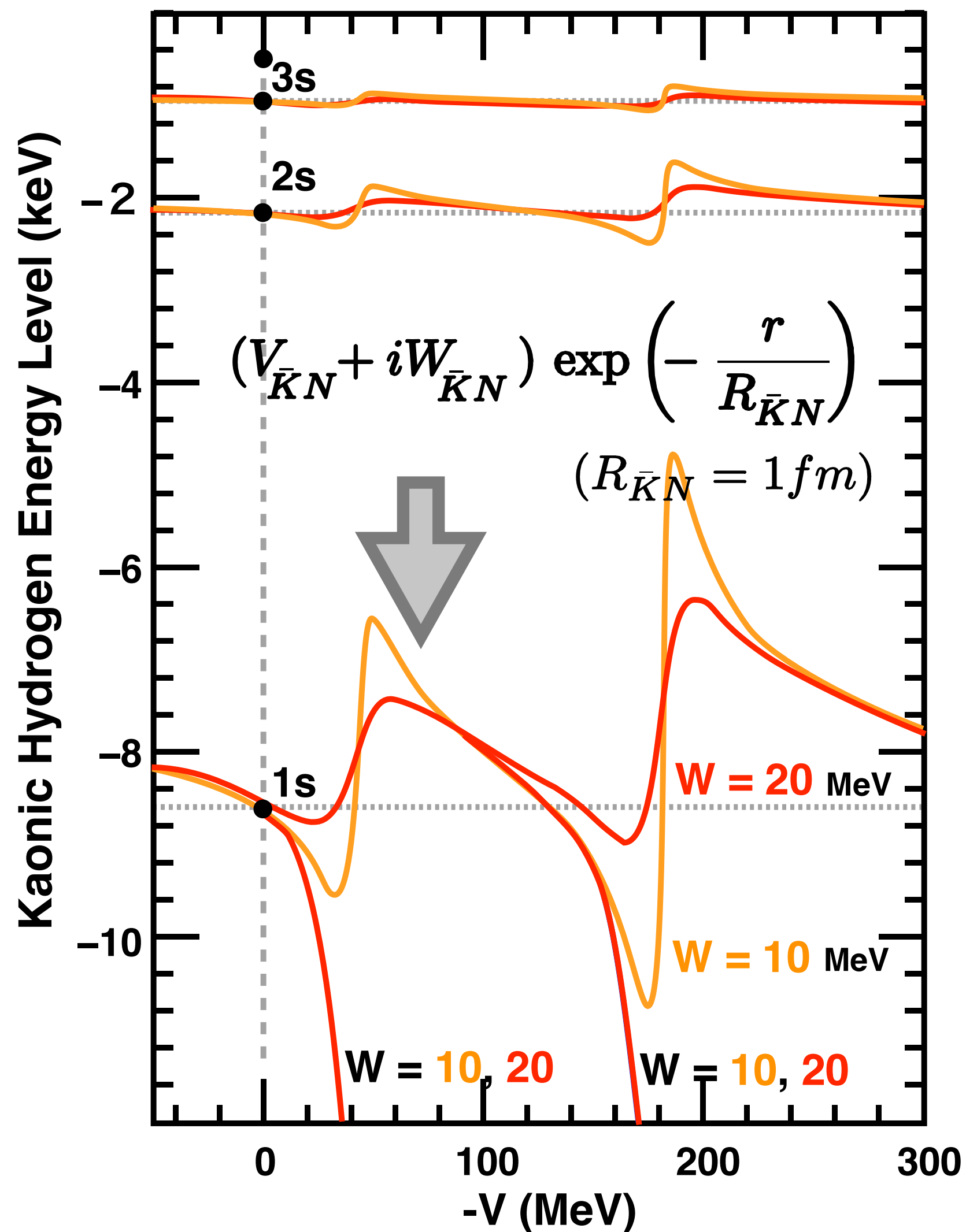

Theoretical calculations for realistic $\bar{K}N$ interaction

R. Seki, Phys. Rev. C5 (1972) 1196

S. Baird et al., Nucl. Phys. A392 (1983) 297

C.J. Batty, Nucl. Phys. A508 (1990) 89c

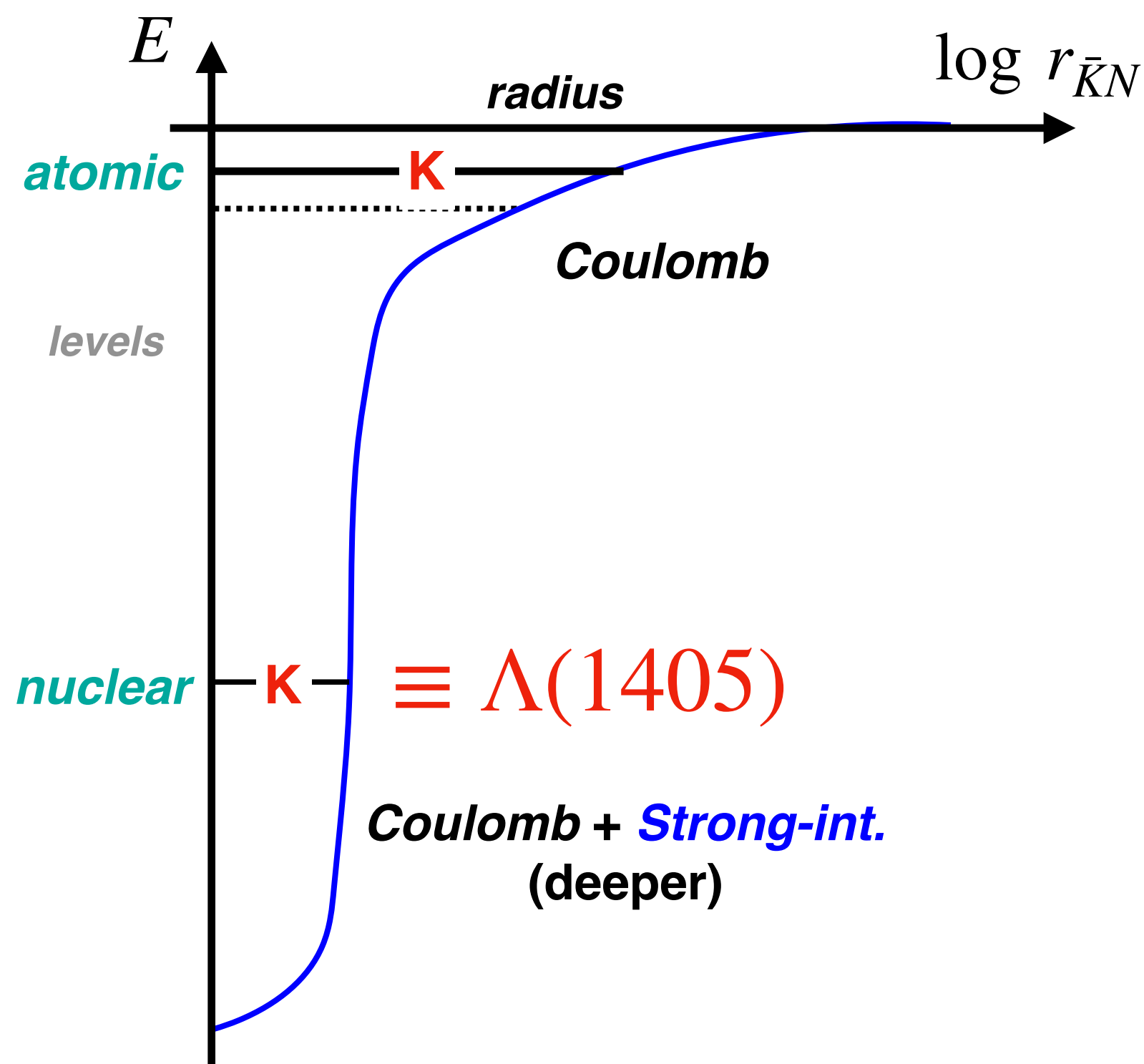

Illustrative Animation

Observed Shift was **REPULSIVE!**

Is $\bar{K}N$ interaction repulsive?

Coulomb + $\bar{K}N$ interaction

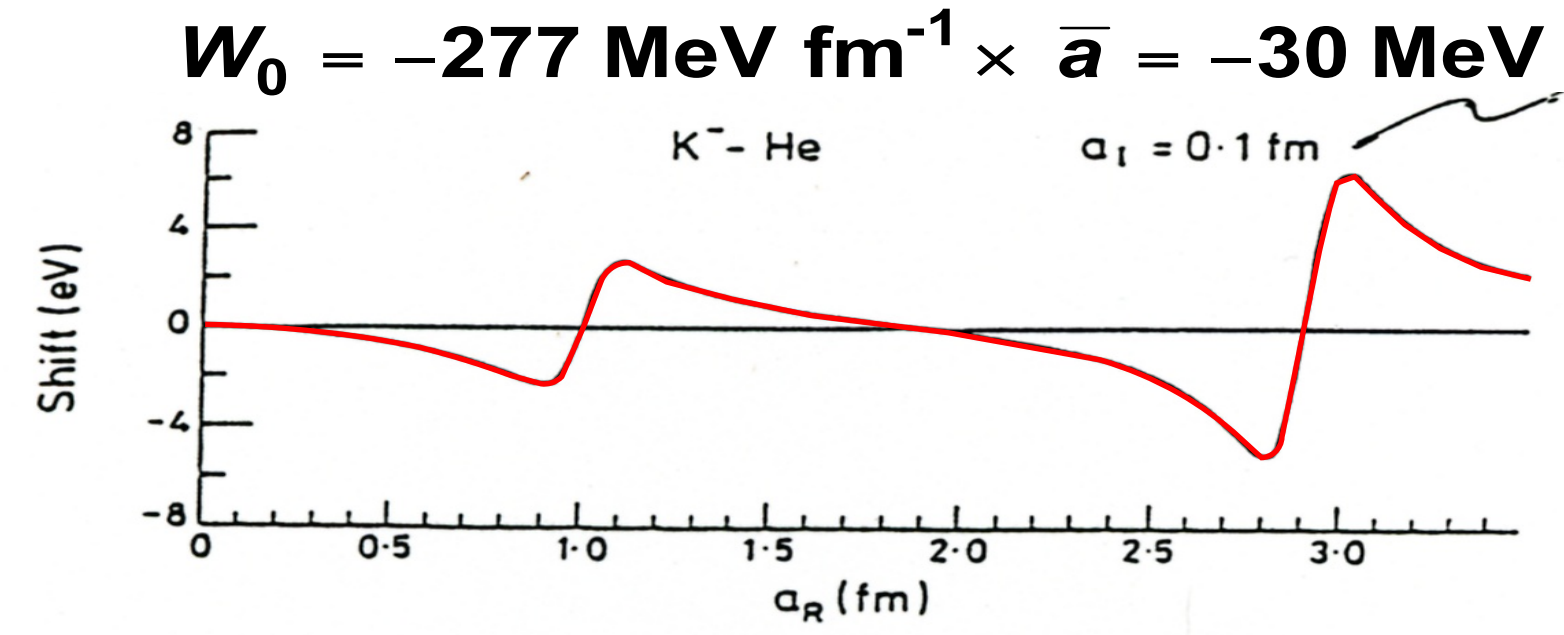
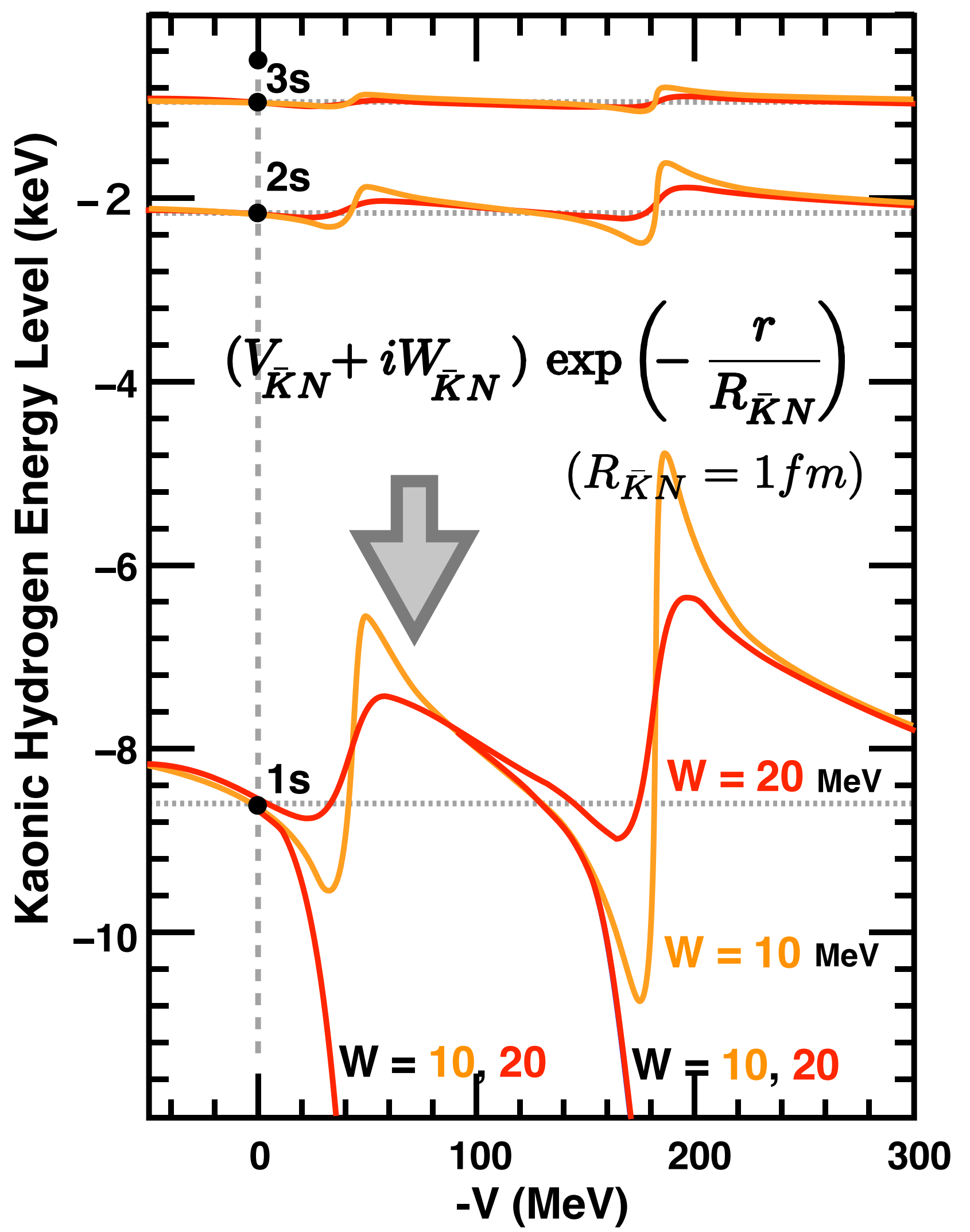

Theoretical calculations for realistic $\bar{K}N$ interaction

R. Seki, Phys. Rev. C5 (1972) 1196
 S. Baird et al., Nucl. Phys. A392 (1983) 297
 C.J. Batty, Nucl. Phys. A508 (1990) 89c

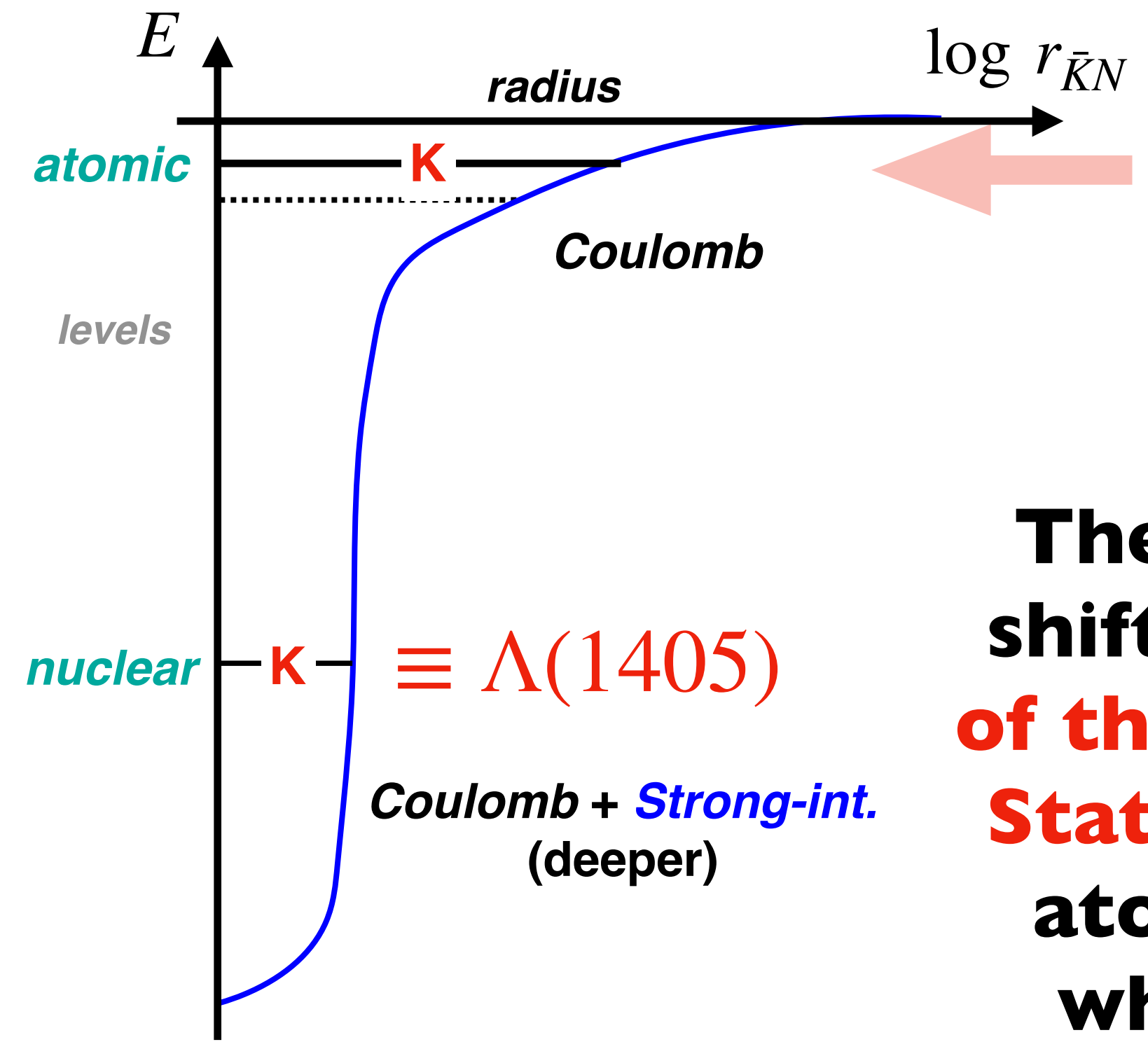

repulsive shift of atomic 1s

The sign flip of the energy shift suggests the existence of the Kaonic Nuclear Bound State because the repulsive atomic shift appears only when the bound state is formed!

Illustrative Animation

As a candidate of K^-p bound state, $\Lambda(1405)$ is the most natural

- Is it quark excited state of Λ baryon (qqq)?

$\Lambda(1405) = \bar{K}N$... a “molecule-like hadron composite”

R.H. Dalitz and S.F. Tuan, Ann. Phys., 3, 307 (1960)

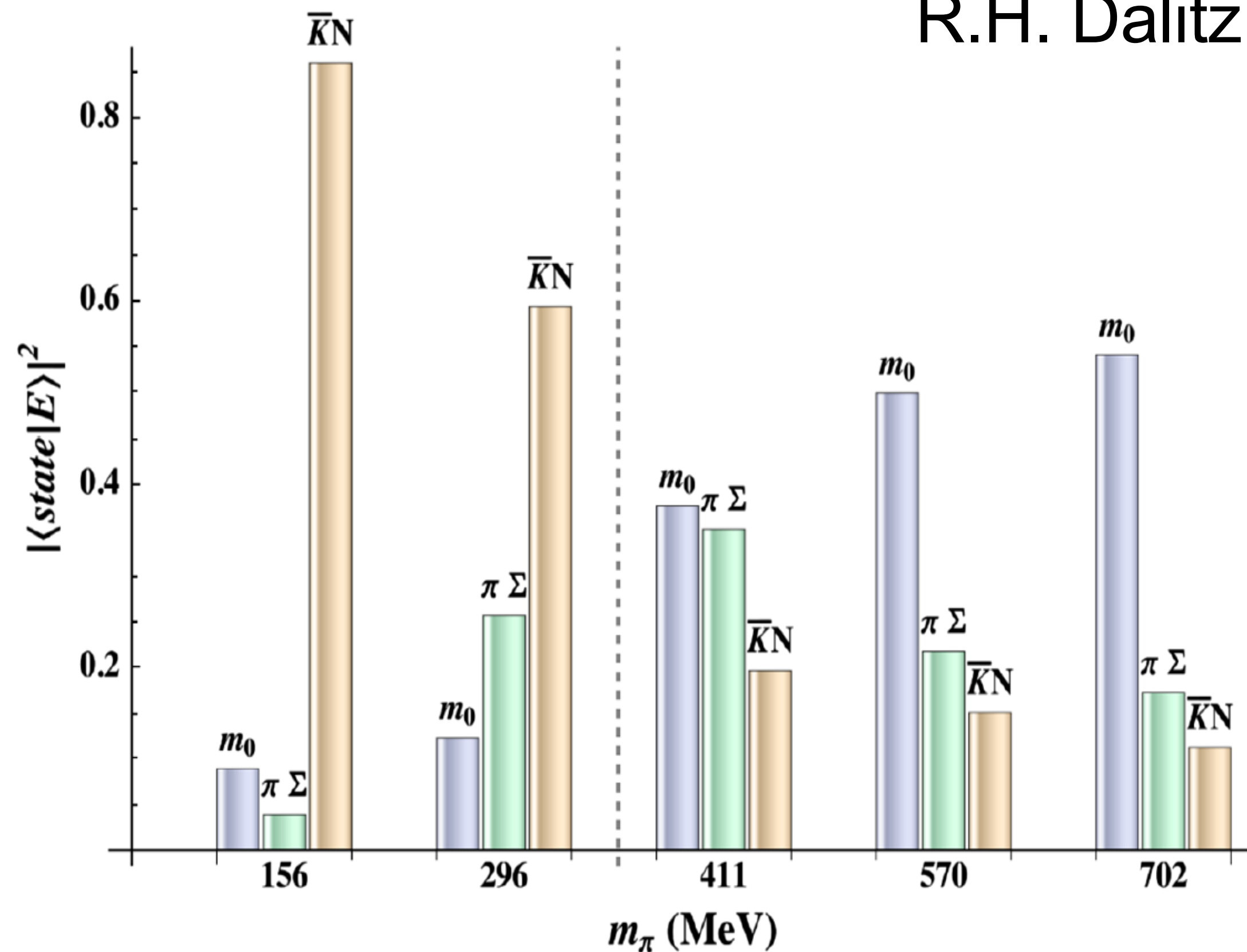

◆ supported by kaonic hydrogen data

Phys. Rev. Lett., 78, 3067 (1997)

◆ supported by Lattice QCD

J.M.M. Hall et al., Phys. Rev. Lett. 114(2015)132002.

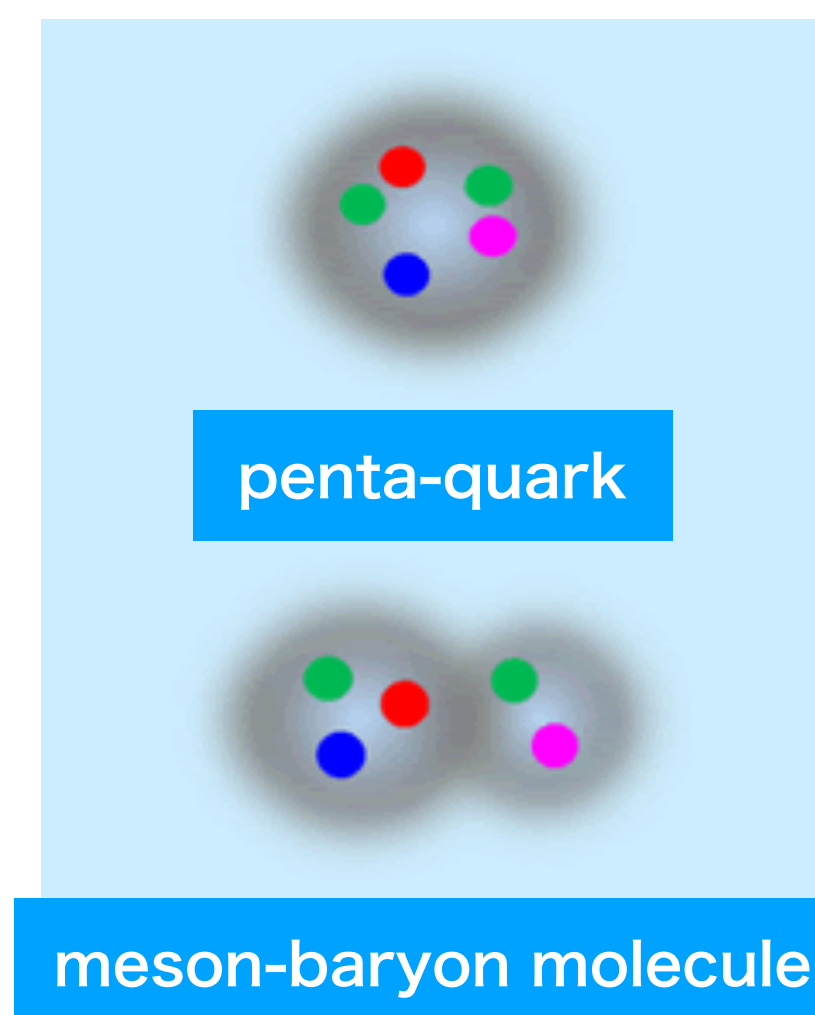

why not $\bar{K}NN$?

forming a nuclear bound state

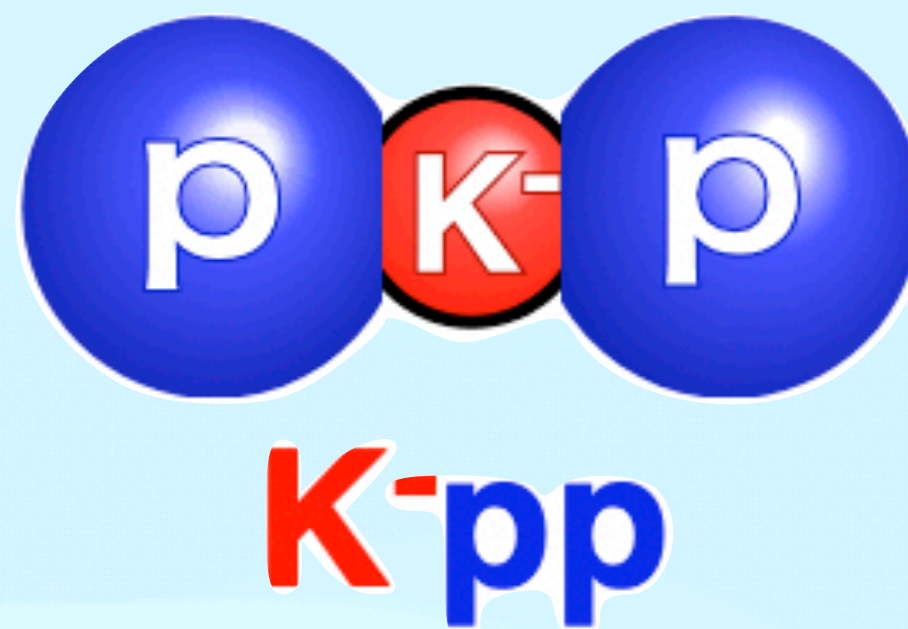

$\bar{K}NN$ bound state as multi-Baryon Hadronic-Molecule / Cluster with Strangeness

- T. Yamaga, S. Ajimura, H. Asano et.al., Phys. Rev. C 110, 014002 (2024)
- T. Hashimoto, S. Ajimura, G. Beer, PTEP (2015) ptep/ptv076.
- S. Ajimura, H. Asano, G. Beer et al. Phys. Lett. B789 (2019) 620.
- T.Yamaga, S. Ajimura, H. Asano et al. Phys. Rev. C102 (2020) 044002.

J-PARC E15: “ K^-pp ” Exploration

$K^- + {}^3\text{He} (ppn)$

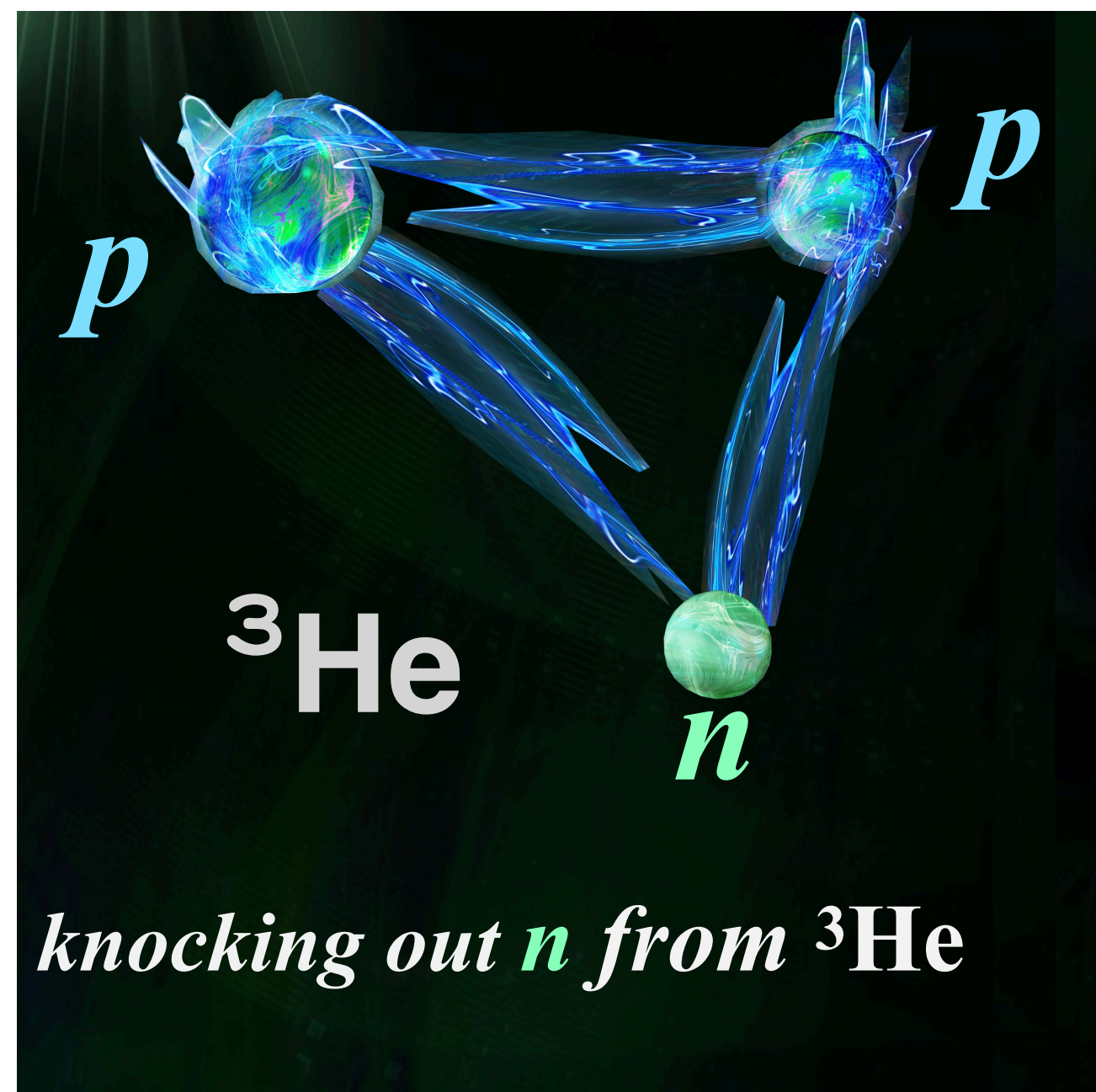

$(K^- + pp) + n$

substitute n in ${}^3\text{He}$ by K^-

J-PARC E15: “ K^-pp ” Exploration

$K^- + {}^3\text{He} (ppn)$

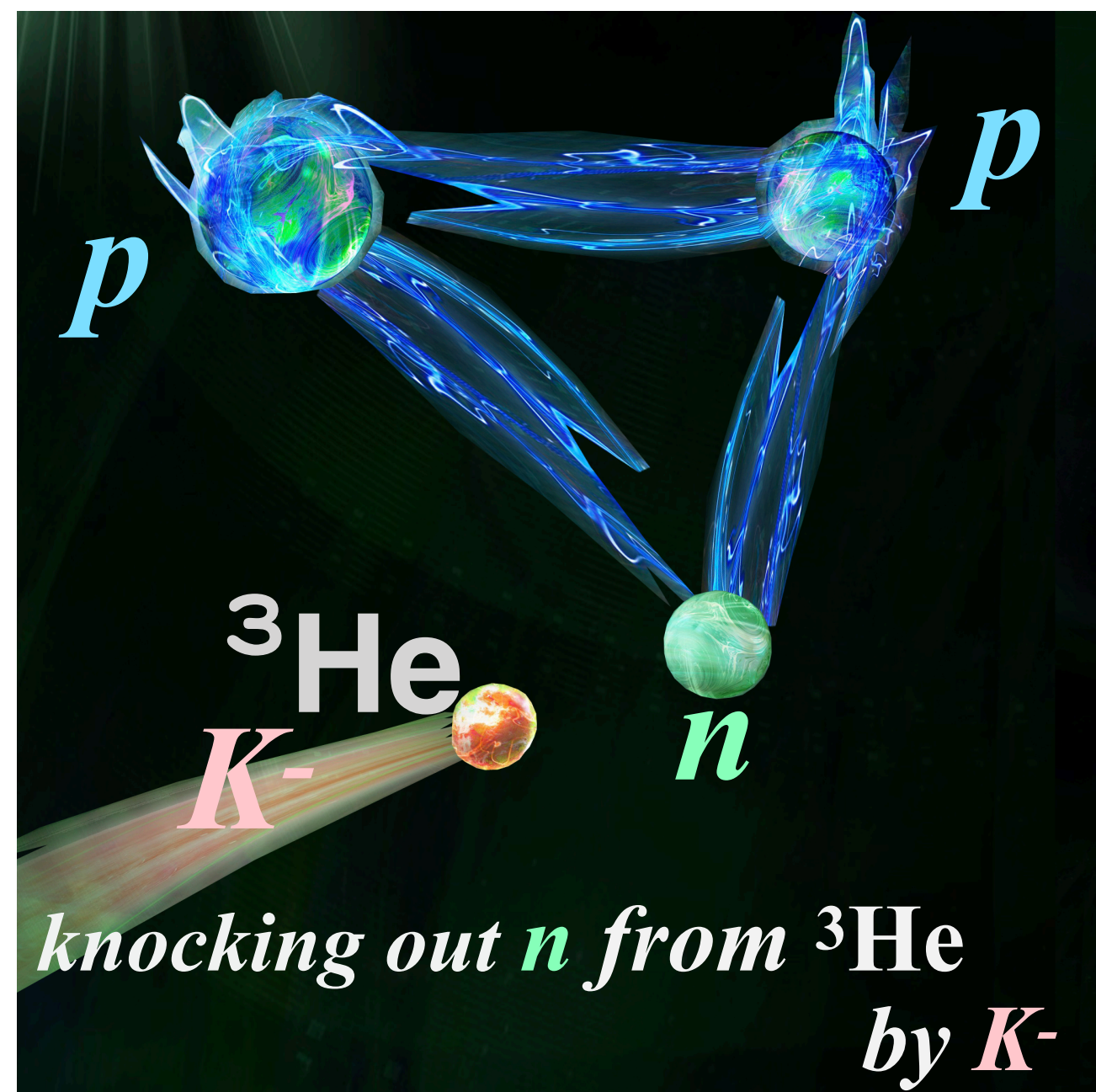

$(K^- + pp) + n$

substitute n in ${}^3\text{He}$ by K^-

J-PARC E15: “ K^-pp ” Exploration

$K^- + {}^3\text{He} (ppn)$

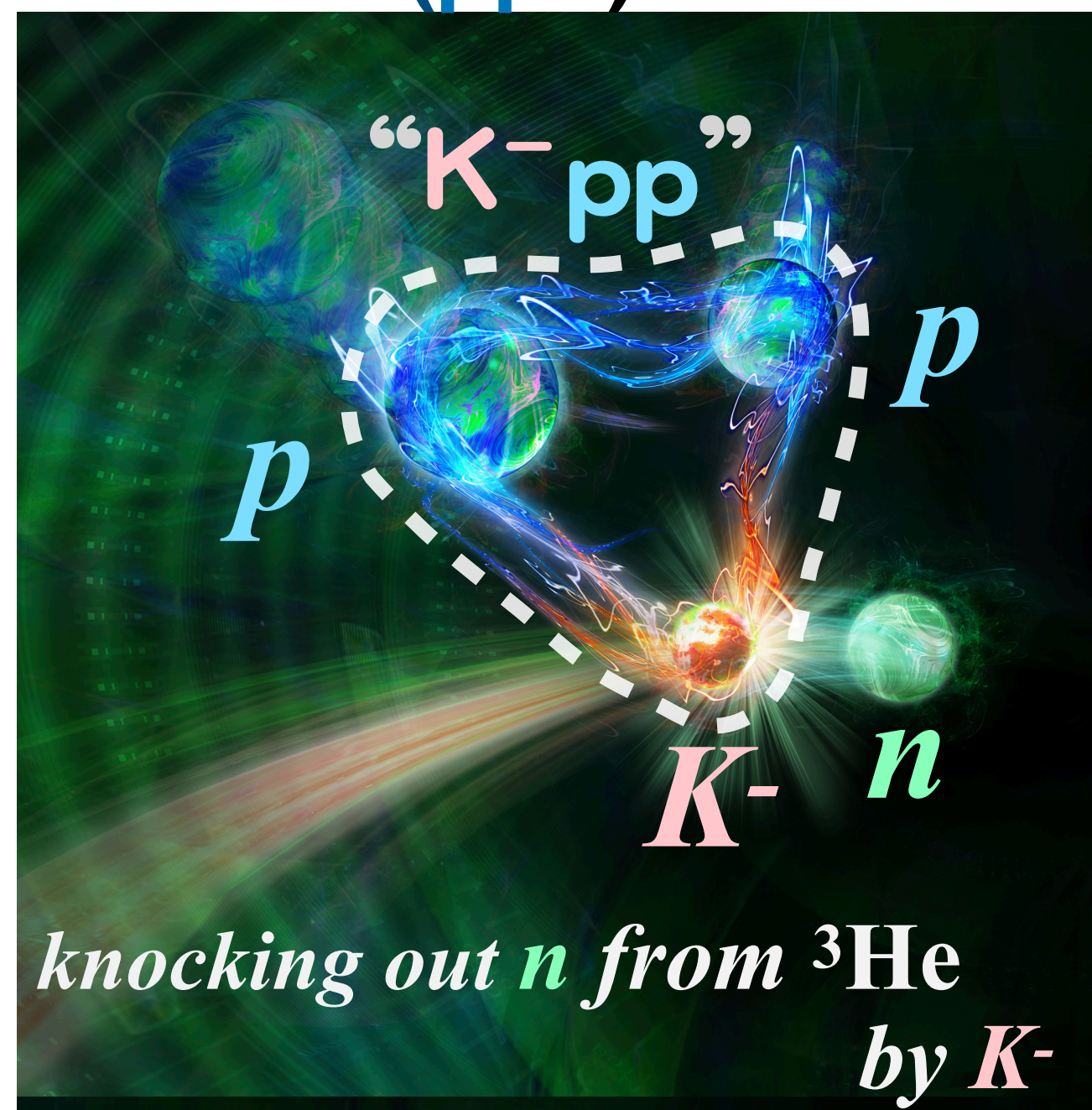

If “ K^-pp ” exists, a peak will be formed in invariant mass spectrum below $M(K^-pp)$

$$M(K^-pp) \equiv m_{K^-} + 2m_p$$



substitute n in ${}^3\text{He}$ by K^-

J-PARC E15: “ K^-pp ” Exploration

$K^- + {}^3\text{He} (ppn)$

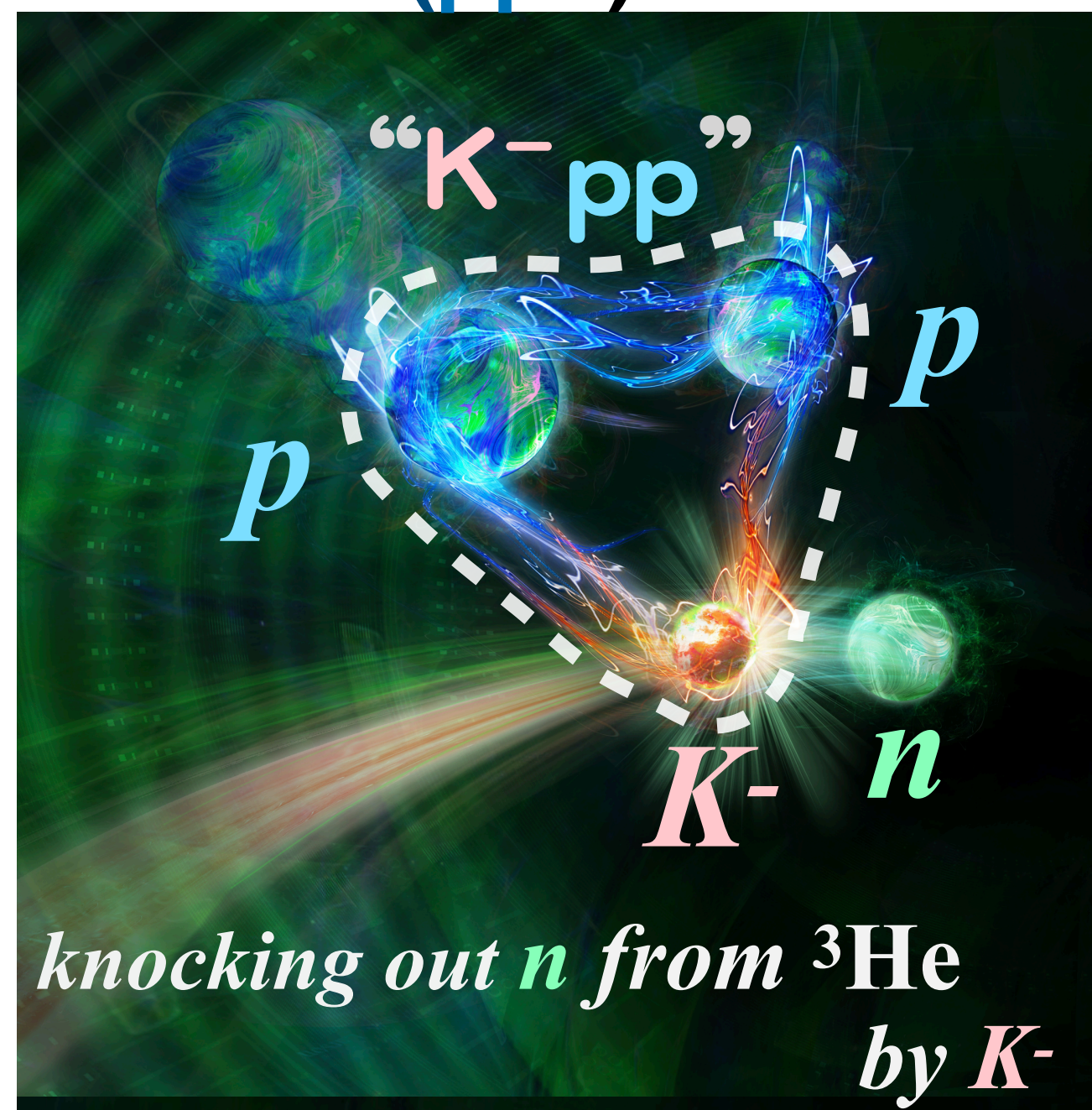

$(K^- + pp) + n$

substitute n in ${}^3\text{He}$ by K^-

If “ K^-pp ” exists, a peak will be formed in invariant mass spectrum below $M(K^-pp)$

$$M(K^-pp) \equiv m_{K^-} + 2m_p$$

kinematically identified

$K^- + {}^3\text{He} \rightarrow (K^- + pp) + n$: formation

$(K^- + pp) \rightarrow \Lambda + p$: decay (M, q)

identified as charged particles

select $K^- + {}^3\text{He} \rightarrow (\Lambda + p) + n$ events,
analyze *invariant mass* M of $(K^- + pp)$ -system
and *momentum transfer* q to the system

provides multi-dimensional kinematical information

Λp $+n$

events

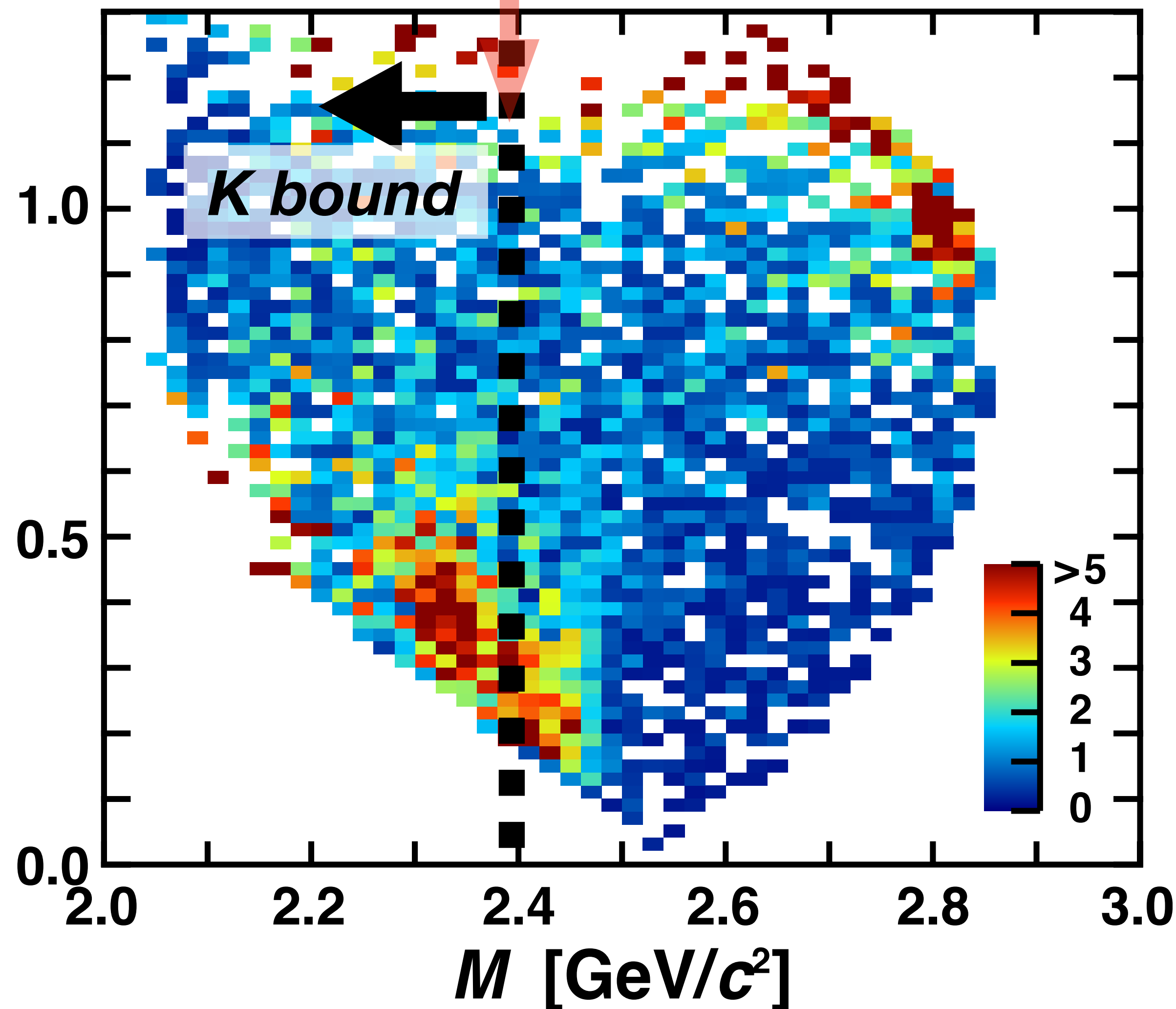
on (M, q) -planeAcceptance corrected event distribution on (M, q) reconstructed " $\bar{K}N$ " mass (M) \rightarrow binding threshold \downarrow q -distribution: system size— high- q capture happens if the system is compact — M -distribution: binding energy & absorption width— sensitive to $\bar{K}N$ interaction — q [GeV/c]

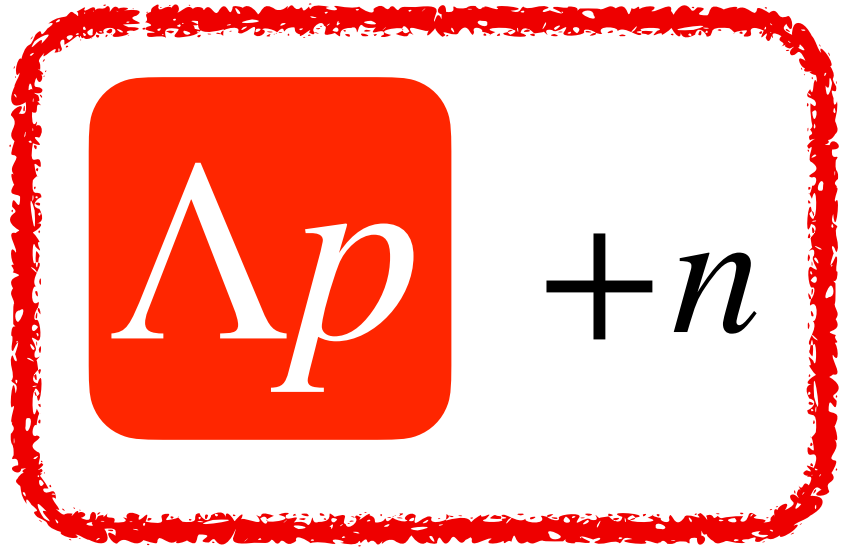

$\Lambda p + n$ events

Acceptance corrected event distribution on (M, q)

on (M, q) -plane

reconstructed " $\bar{K}NN$ " mass (M)

binding threshold

q -distribution: system size

— high- q capture happens if the system is compact —

M -distribution: binding energy & absorption width

— sensitive to $\bar{K}N$ interaction —

The K -pp signal is clearly seen on (M, q) -plane!

— relatively deep and wide, and extended to high- q region —

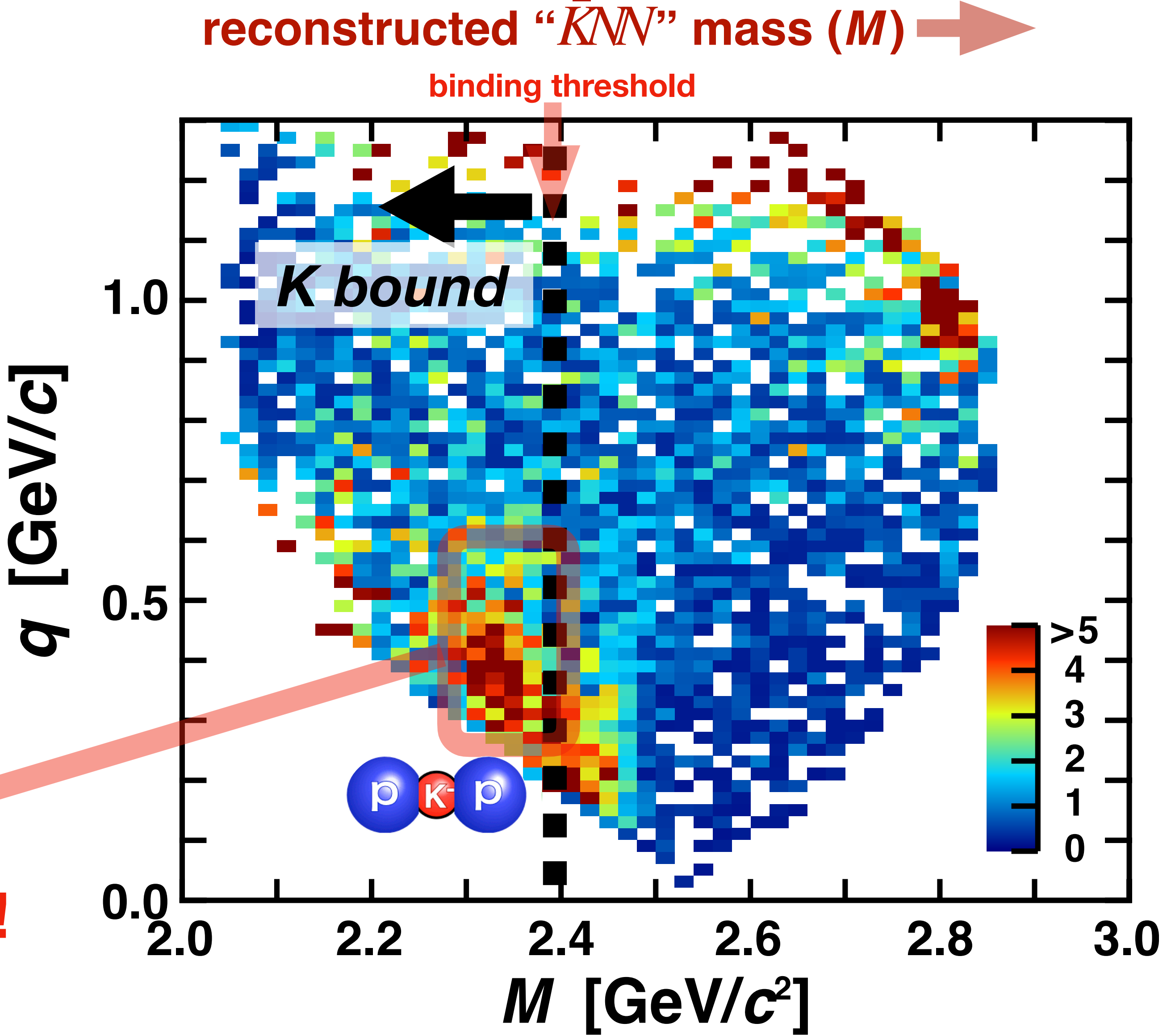

momentum transfer (q) to " $\bar{K}NN$ "

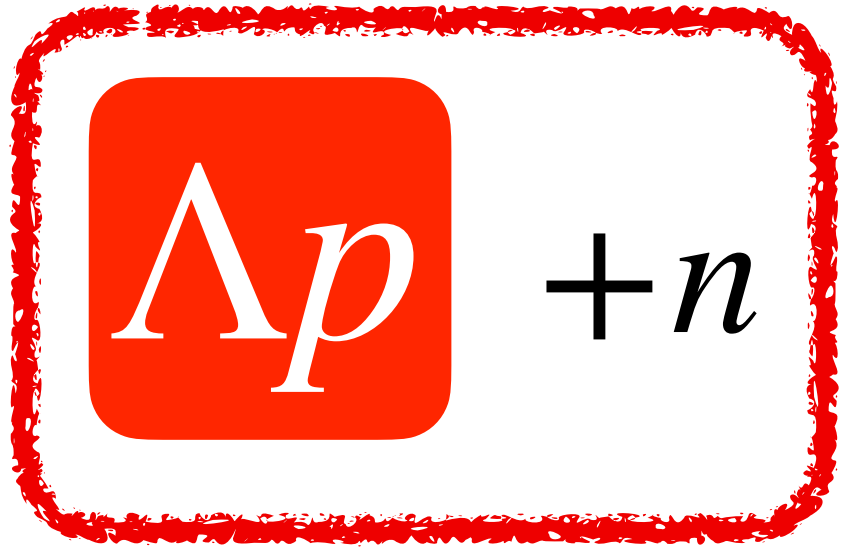

$\Lambda p + n$ events

Acceptance corrected event distribution on (M, q)

on (M, q) -plane

q-distribution: system size
— high- q capture happens if the system is compact —

M-distribution: binding energy & absorption width
— sensitive to $\bar{K}N$ interaction —

The K-pp signal is clearly seen on (M, q) -plane!
— relatively deep and wide, and extended to high- q region —

reconstructed " $\bar{K}N$ " mass (M) →

binding threshold

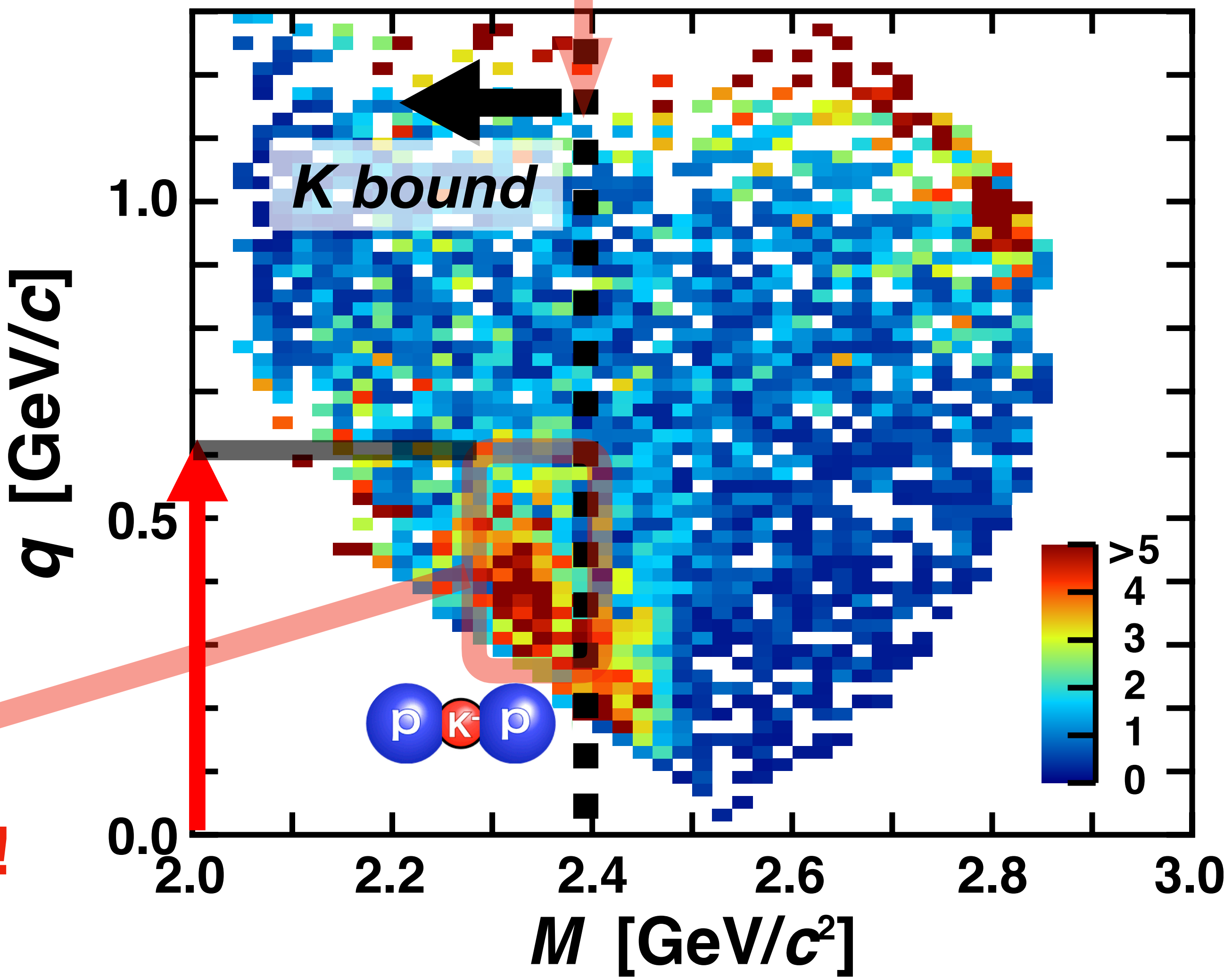

momentum transfer (q) to " $\bar{K}N$ " ↑

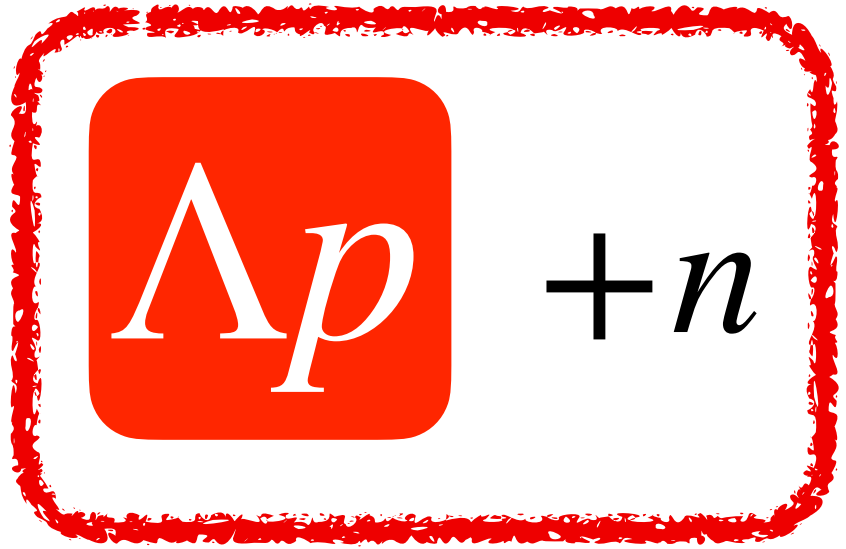

$\Lambda p + n$ events

Acceptance corrected event distribution on (M, q)

on (M, q) -plane

q-distribution: system size

— high- q capture happens if the system is compact —

M-distribution: binding energy & absorption width

— sensitive to $\bar{K}N$ interaction —

The K-pp signal is clearly seen on (M, q) -plane!

— relatively deep and wide, and extended to high- q region —

reconstructed " $\bar{K}N$ " mass (M)

binding threshold

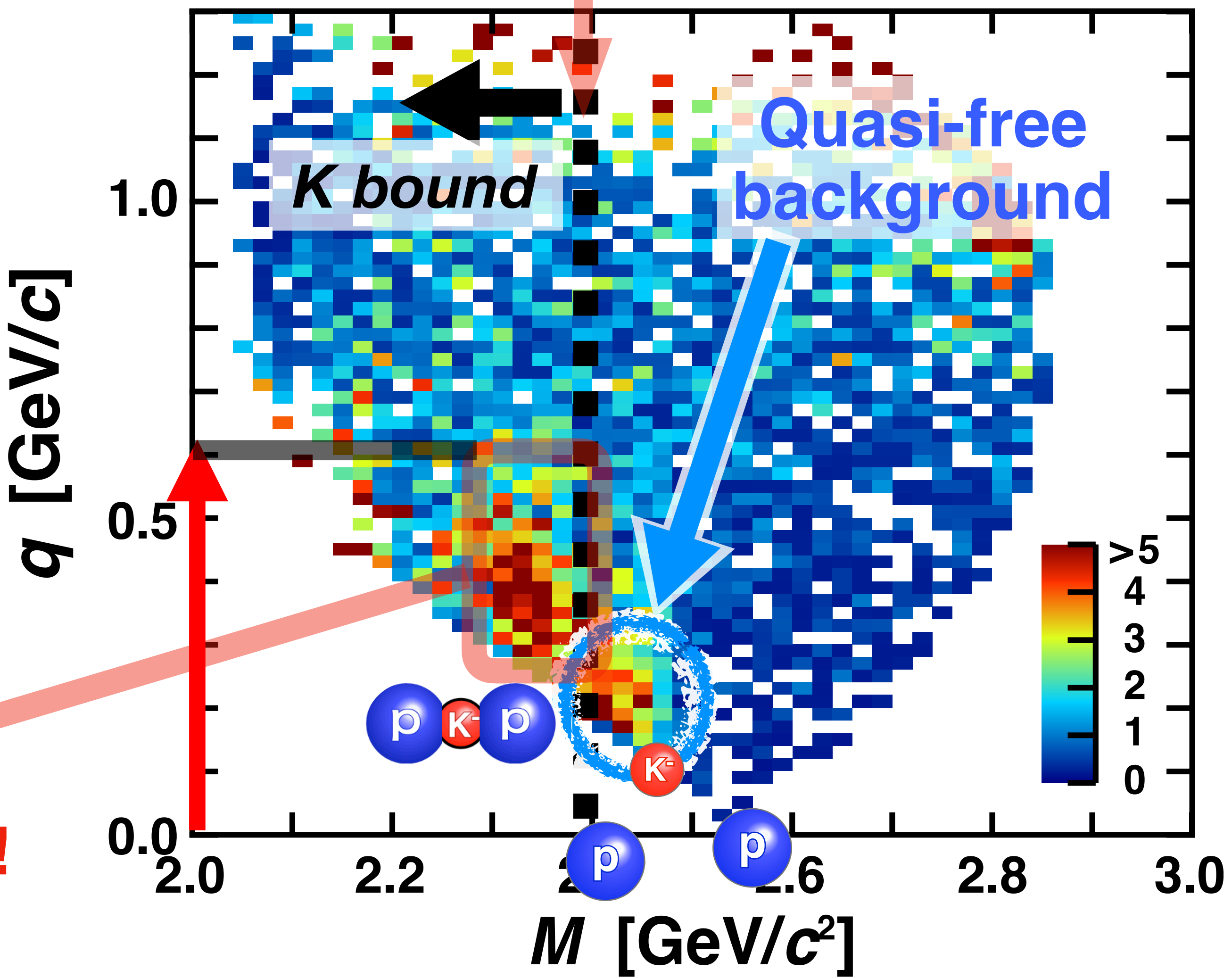

momentum transfer (q) to " $\bar{K}N$ "

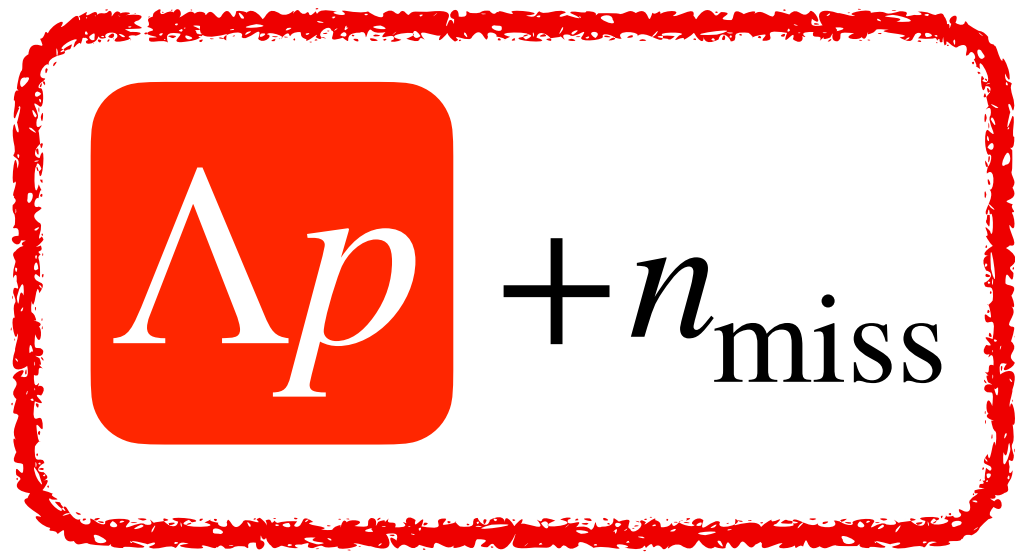

Phenomenological model fitting function in (m, q) -plane

ρ : Lorentz-invariant phase-space

$$f_{\bar{K}NN}(m, q) \times \rho_{\{\Lambda pn\}}(m, q) \quad f_{QF-\bar{K}}(m, q) \times \rho_{\{\Lambda pn\}}(m, q)$$

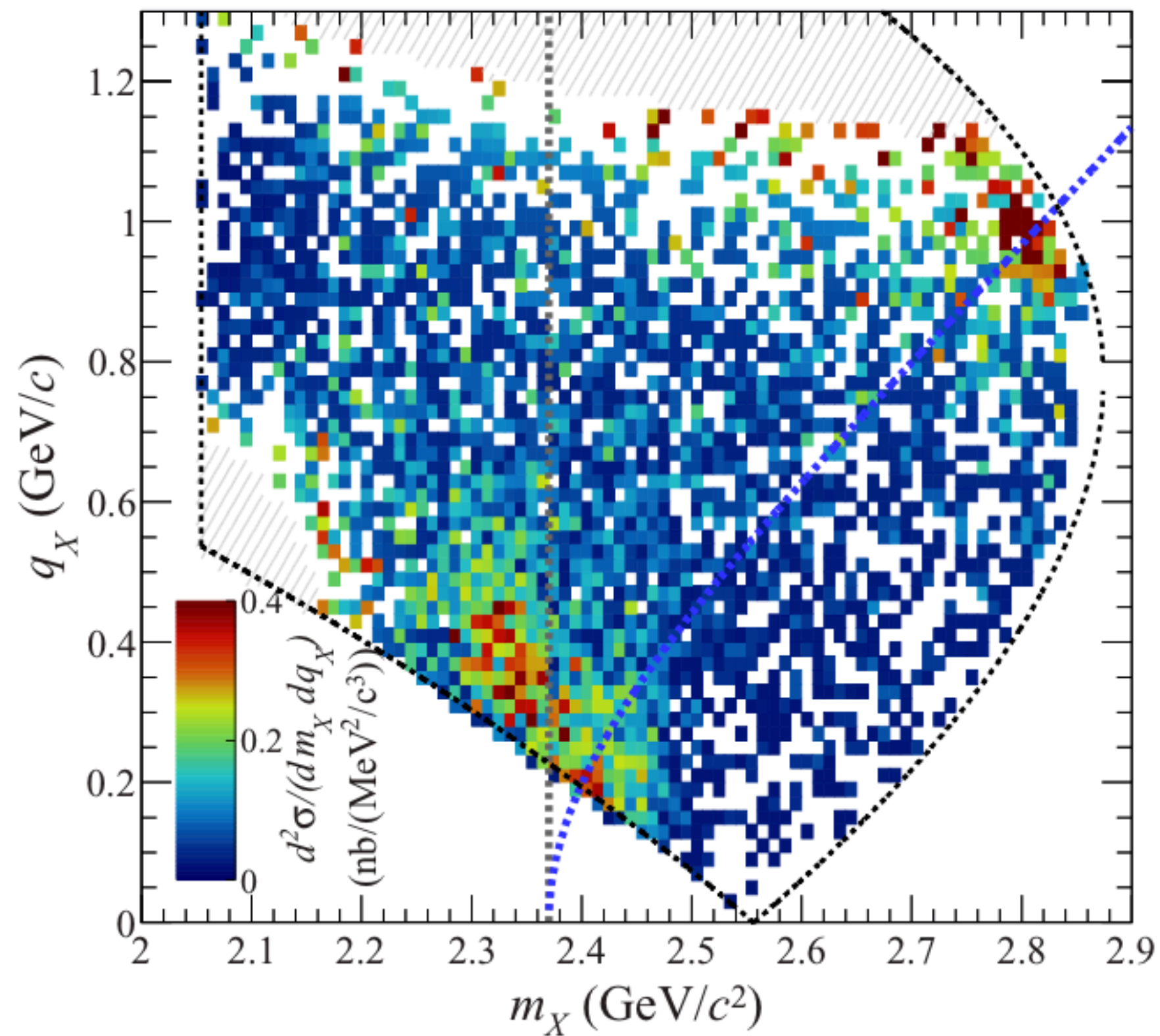

$\bar{K}NN$ production

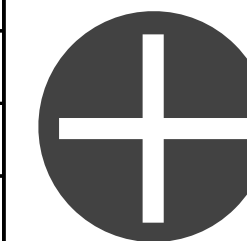
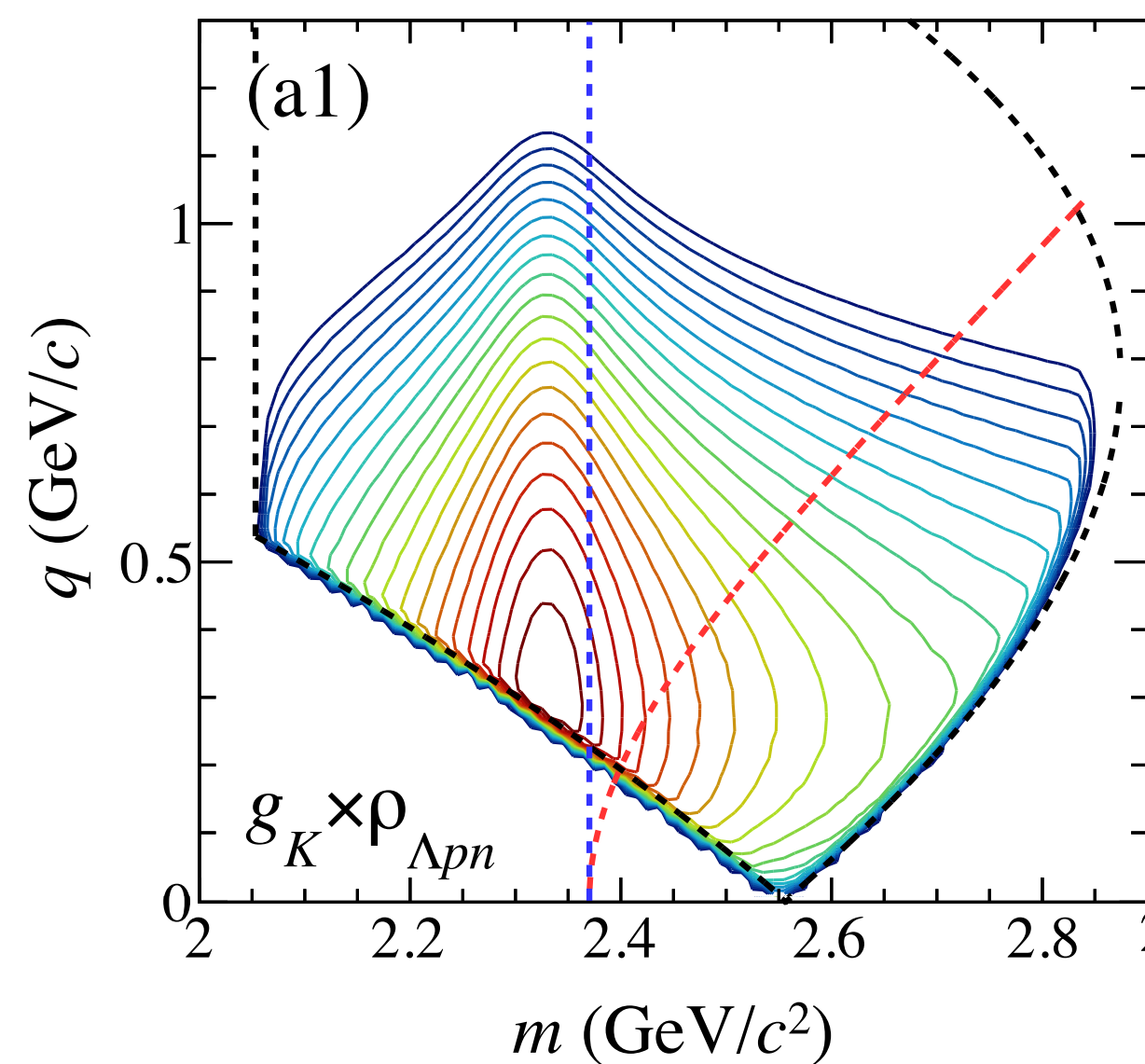

QF- \bar{K} absorption

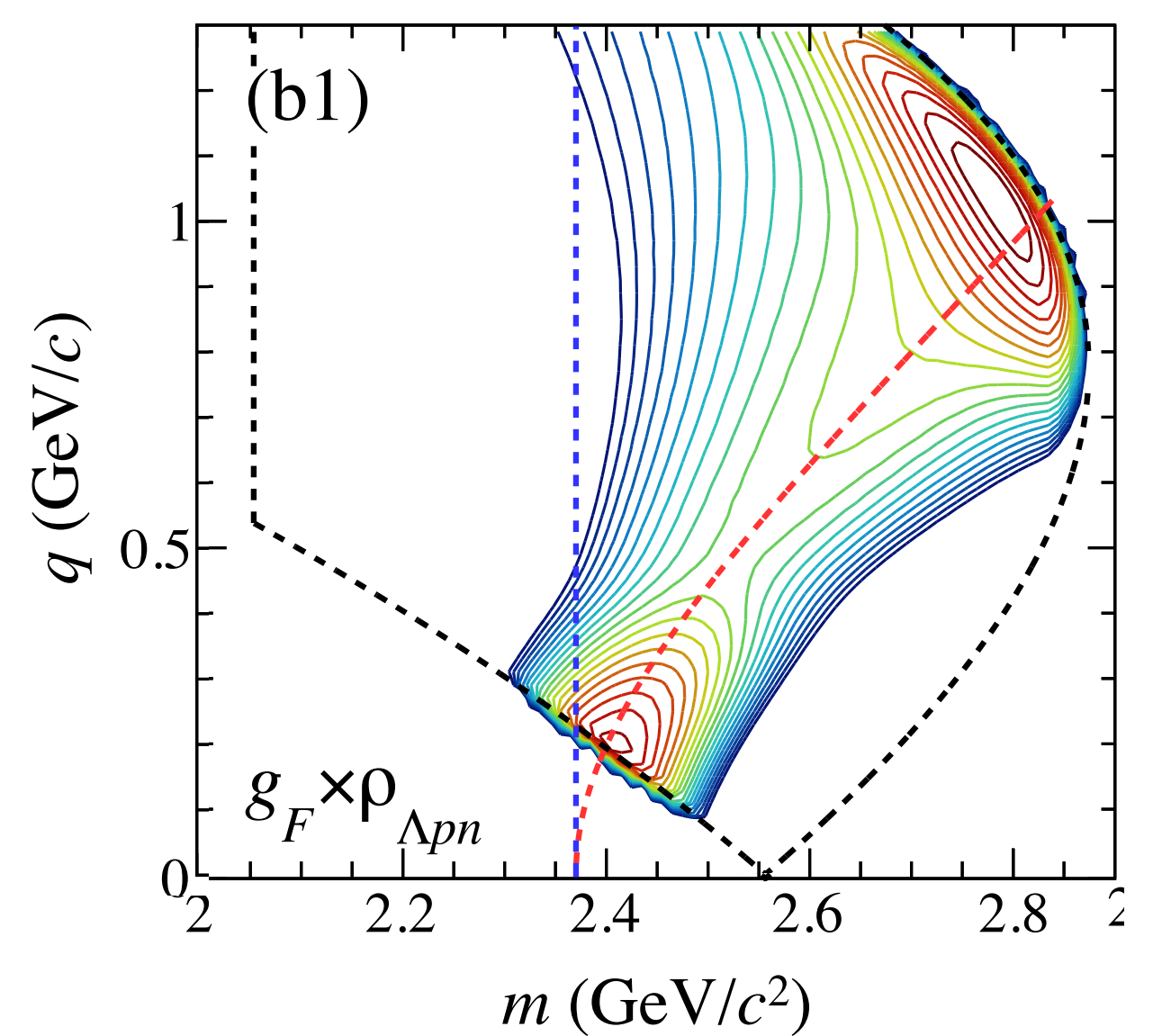

$$f_{\bar{K}NN}(m, q) : \quad B.W.(m) \times \text{form factor}(q)$$

$$f_{QF-\bar{K}}(m, q) : \quad \text{phenomenological}$$

PWIA based interpretation

(plane wave impulse approximation)

$$\sigma(M, q) \propto \rho_{3B}(M, q) \times \frac{(\Gamma_{Kpp}/2)^2}{(M - M_{Kpp})^2 + (\Gamma_{Kpp}/2)^2} \times \exp\left(-\frac{q^2}{Q_{Kpp}^2}\right)$$

Differential
cross section

PWIA based interpretation

(plane wave impulse approximation)

$$\sigma(M, q) \propto \rho_{3B}(M, q) \times \frac{(\Gamma_{Kpp}/2)^2}{(M - M_{Kpp})^2 + (\Gamma_{Kpp}/2)^2} \times \exp\left(-\frac{q^2}{Q_{Kpp}^2}\right)$$

Differential
cross section

Lorentz invariant
phase space (Λp_n)

PWIA based interpretation

— from time integral —

B.W. / Lorentzian

(plane wave impulse approximation)

$$\sigma(M, q) \propto$$

$$\rho_{3B}(M, q) \times$$

Differential
cross section

Lorentz invariant
phase space (Λp)

$$\frac{(\Gamma_{Kpp}/2)^2}{(M - M_{Kpp})^2 + (\Gamma_{Kpp}/2)^2} \times \exp\left(-\frac{q^2}{Q_{Kpp}^2}\right)$$

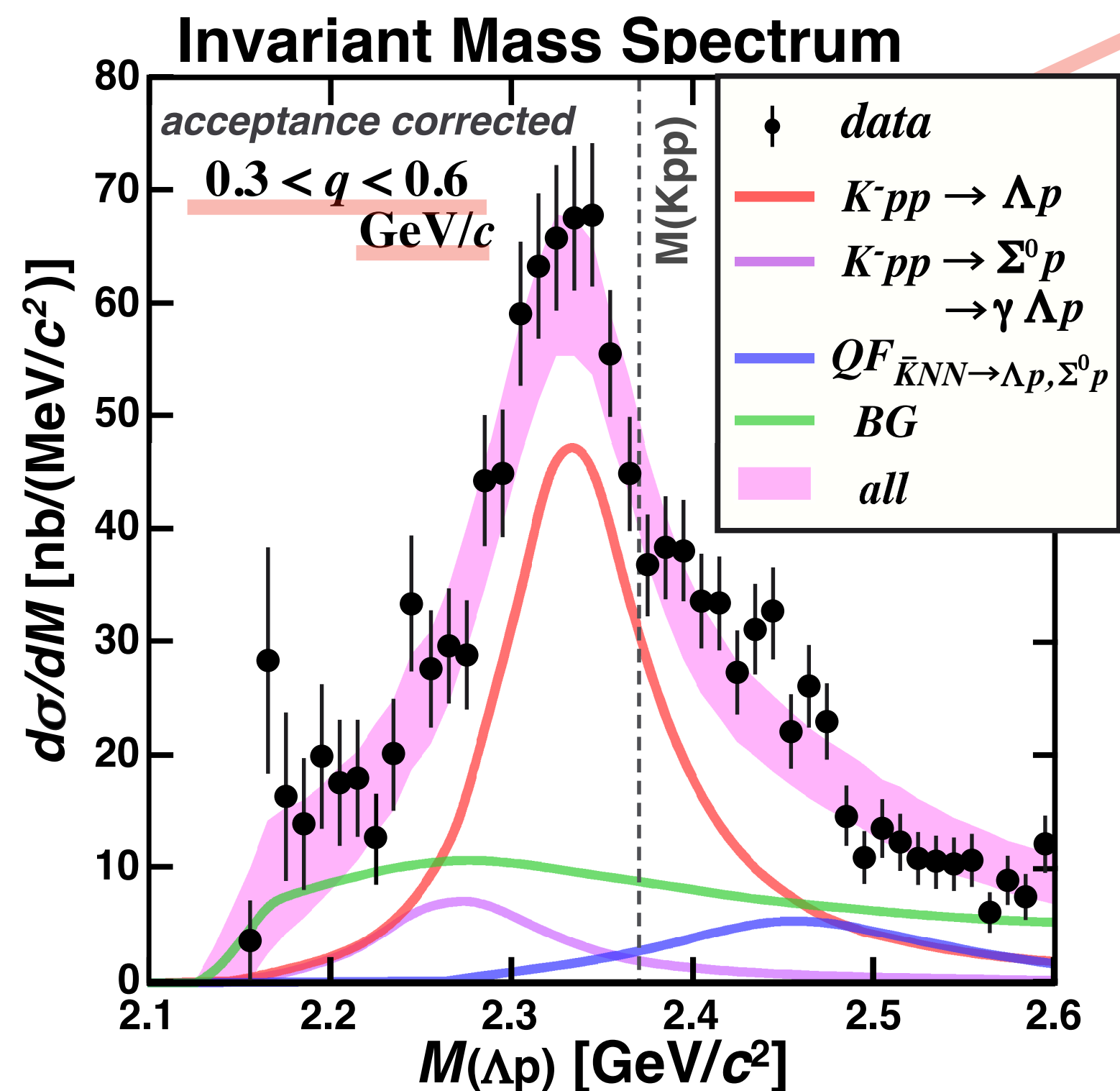

strong binding ($\bar{K}N$ attraction)

$$B_{Kpp} \sim 40 \text{ MeV}, \quad \Gamma_{Kpp} \sim 100 \text{ MeV}$$

PWIA based interpretation

— from time integral — — from space integral —

B.W. / Lorentzian

Gaussian form factor / structure factor

(plane wave impulse approximation)

$$\sigma(M, q) \propto$$

$$\rho_{3B}(M, q) \times$$

Differential cross section

Lorentz invariant phase space (Λp)

$$\frac{(\Gamma_{Kpp}/2)^2}{(M - M_{Kpp})^2 + (\Gamma_{Kpp}/2)^2}$$

$$\times \exp\left(-\frac{q^2}{Q_{Kpp}^2}\right)$$

Fourier Transformation of S-wave Harmonic Oscillator (HO)
— from spatial integral —

Invariant Mass Spectrum

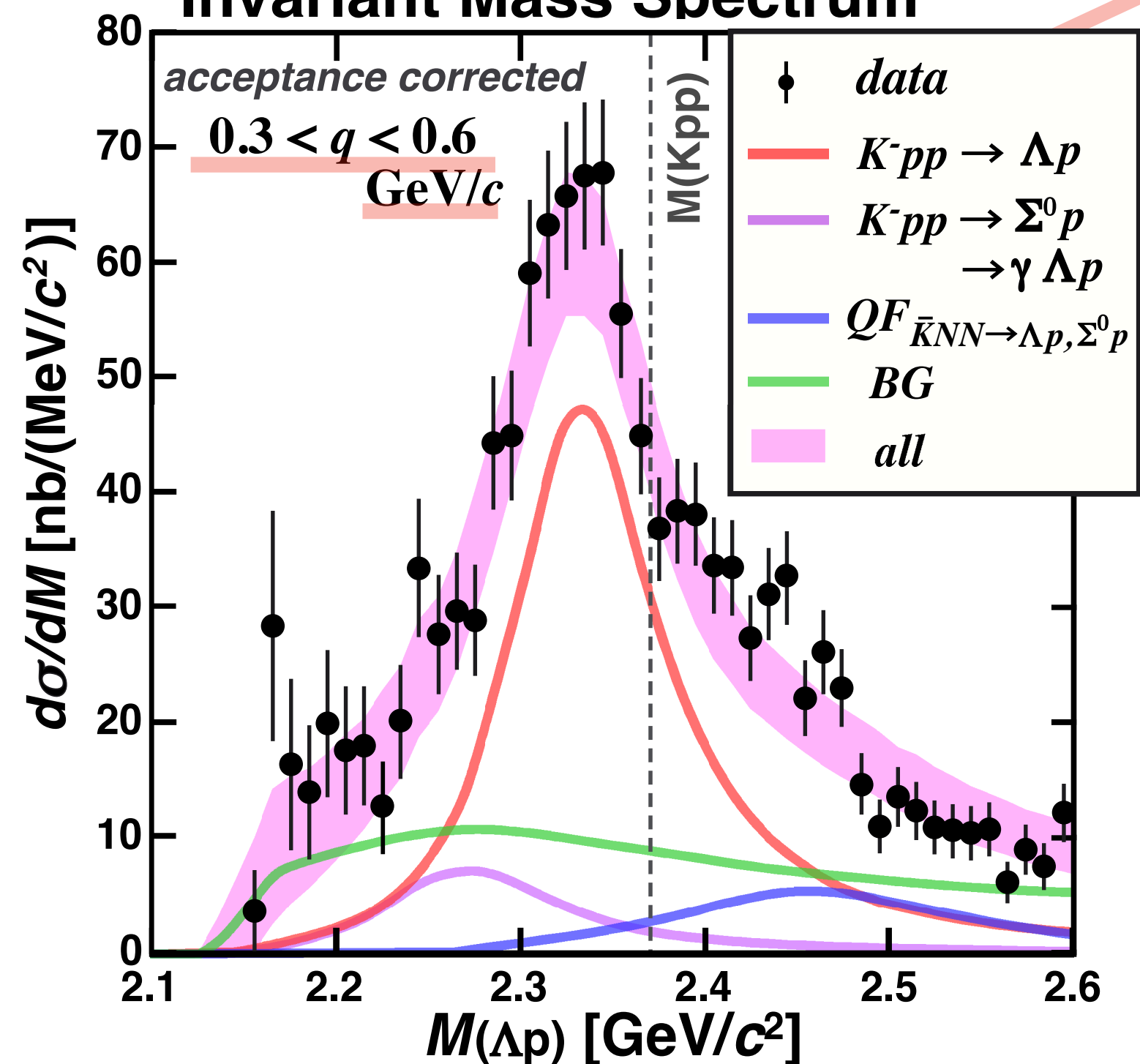

Momentum Transfer Spectrum

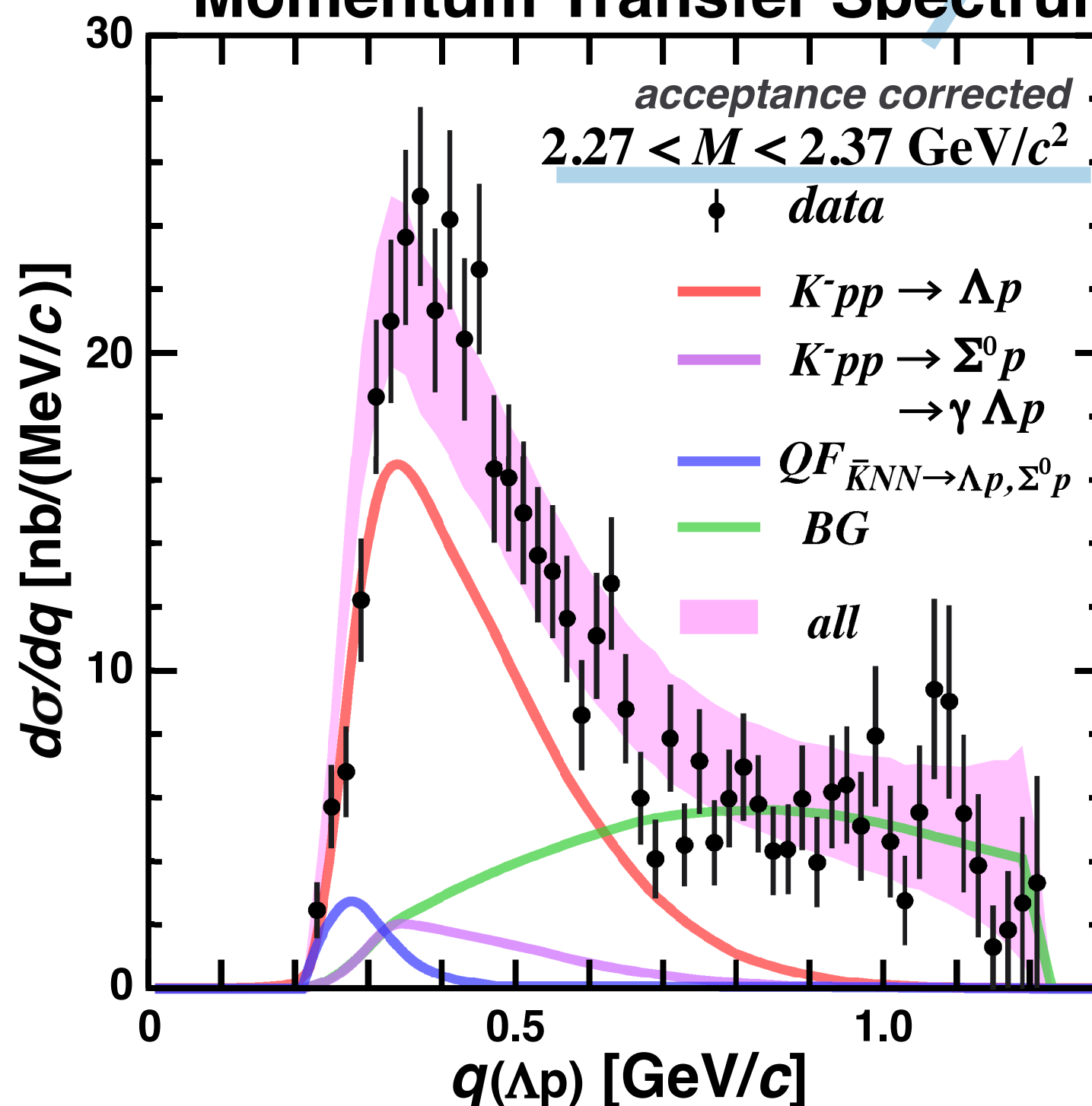

strong binding ($\bar{K}N$ attraction)

$$B_{Kpp} \sim 40 \text{ MeV}, \quad \Gamma_{Kpp} \sim 100 \text{ MeV}$$

wide momentum width

$$Q_{Kpp} \sim 400 \text{ MeV/c}$$

PWIA based interpretation

— from time integral — — from space integral —

B.W. / Lorentzian

Gaussian form factor / structure factor

(plane wave impulse approximation)

$$\sigma(M, q) \propto$$

$$\rho_{3B}(M, q) \times$$

Differential cross section

Lorentz invariant phase space ($\Lambda p n$)

$$\frac{(\Gamma_{Kpp}/2)^2}{(M - M_{Kpp})^2 + (\Gamma_{Kpp}/2)^2}$$

$$\times \exp\left(-\frac{q^2}{Q_{Kpp}^2}\right)$$

Fourier Transformation of S-wave Harmonic Oscillator (HO)
— from spatial integral —

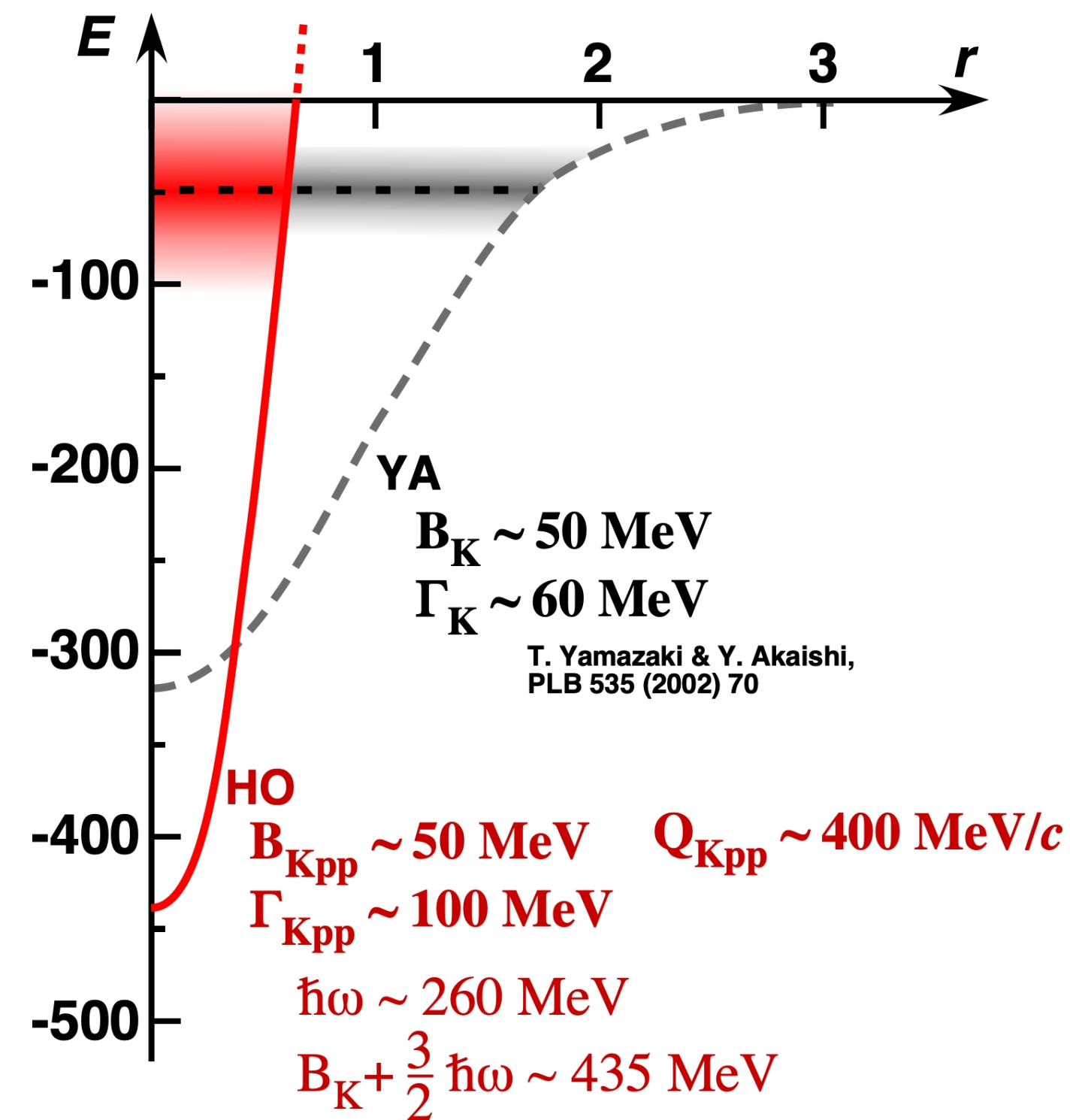
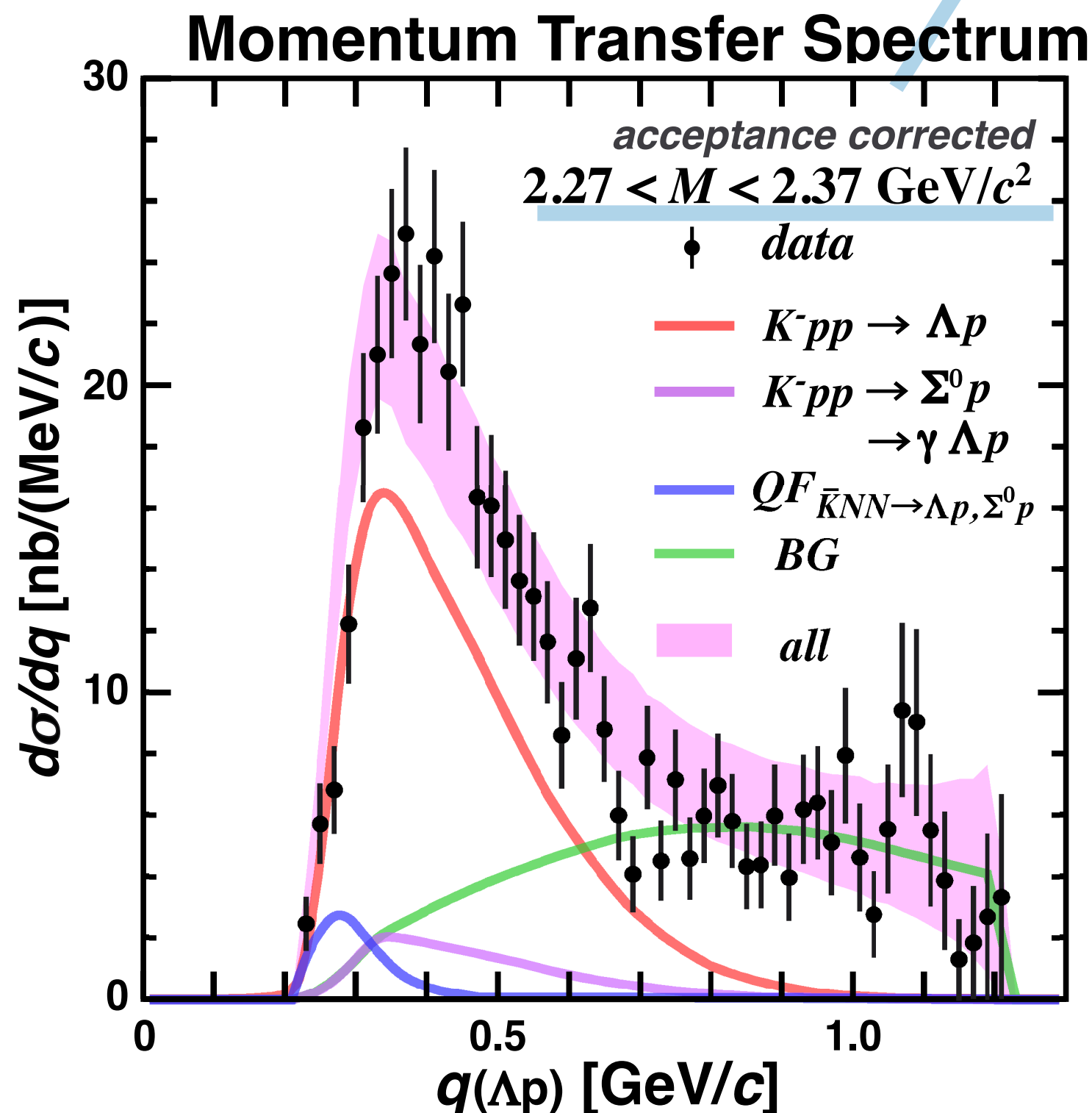
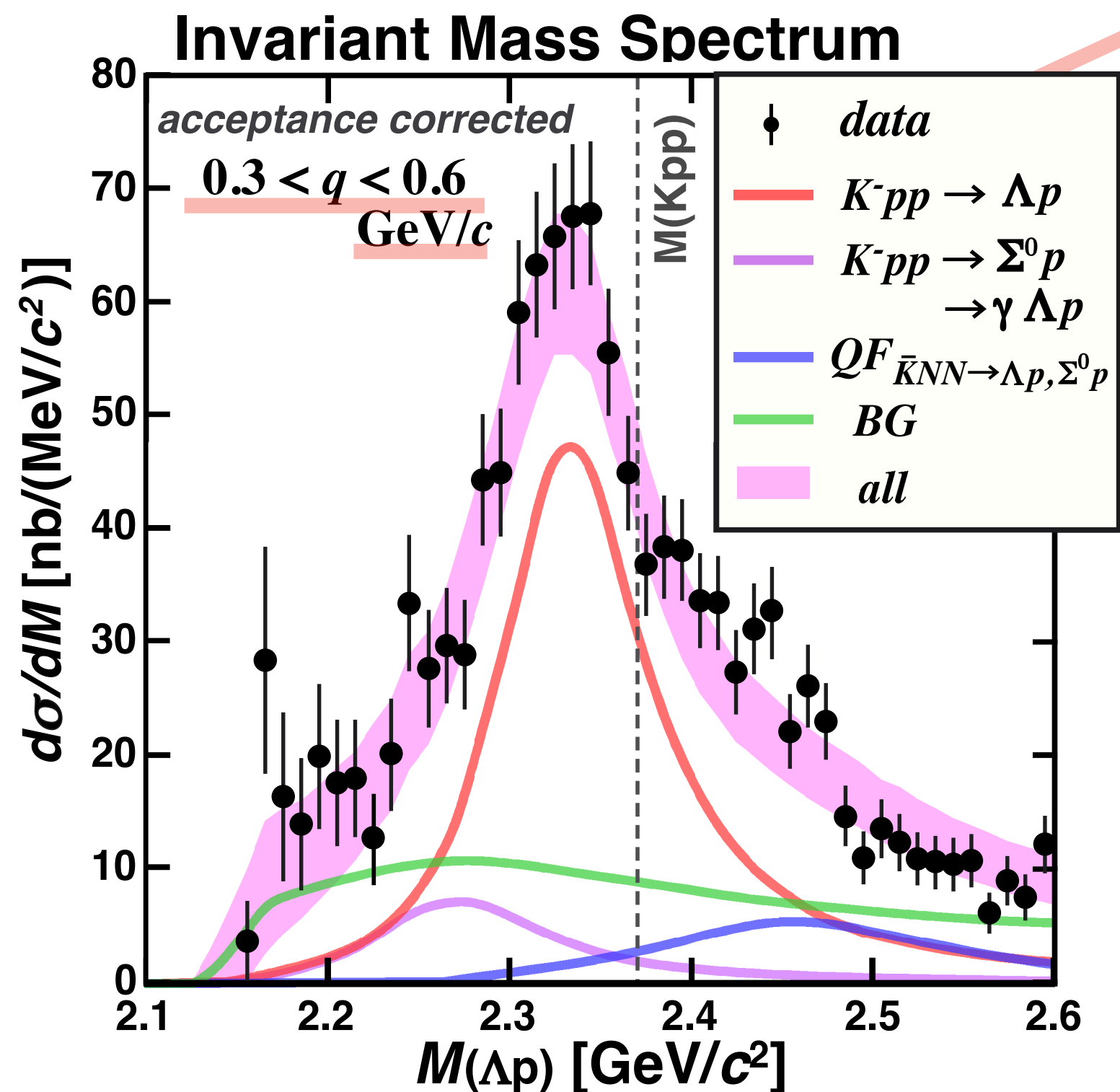

strong binding ($\bar{K}N$ attraction)

$B_{Kpp} \sim 40 \text{ MeV}, \Gamma_{Kpp} \sim 100 \text{ MeV}$

wide momentum width

$Q_{Kpp} \sim 400 \text{ MeV/c}$

... could be quite compact ...

($R_{Kpp} \sim 0.6 \text{ fm (H.O.)}$)

Signal of $\bar{K}NNN$?

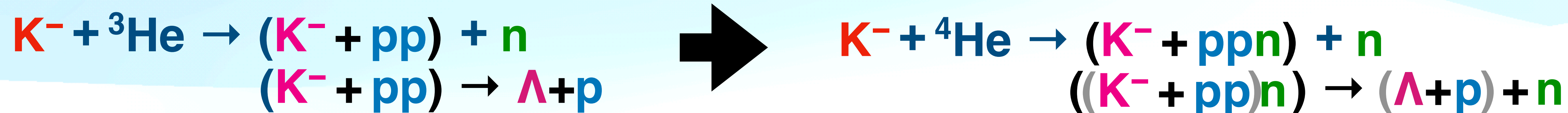

Preliminary data analysis for $\bar{K}NNN$ formation study utilizing ${}^4_{\Lambda}\text{He}$ lifetime measurement via $K^- + {}^4\text{He} \rightarrow \pi^0 + {}^4_{\Lambda}\text{He}$ reaction giving us a very interesting result

Signal of $\bar{K}NNN$?

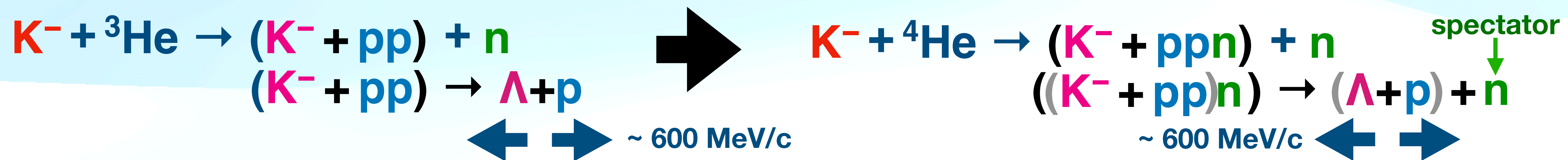

Preliminary data analysis for $\bar{K}NNN$ formation study utilizing ${}^4_{\Lambda}\text{He}$ lifetime measurement via $K^- + {}^4\text{He} \rightarrow \pi^0 + {}^4_{\Lambda}\text{He}$ reaction giving us a very interesting result

Signal of $\bar{K}NNN$?

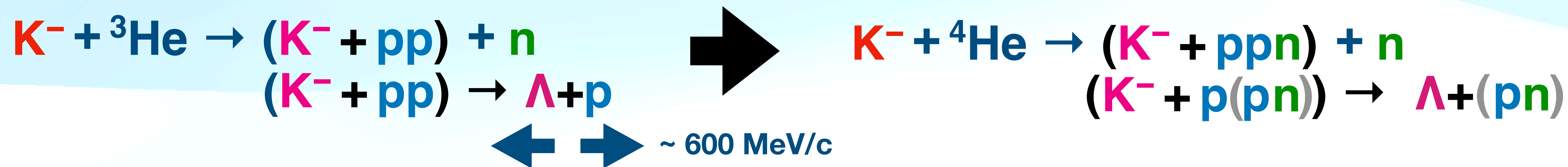

Preliminary data analysis for $\bar{K}NNN$ formation study utilizing ${}^4_{\Lambda}\text{He}$ lifetime measurement via $K^- + {}^4\text{He} \rightarrow \pi^0 + {}^4_{\Lambda}\text{He}$ reaction giving us a very interesting result

Signal of $\bar{K}NNN$?

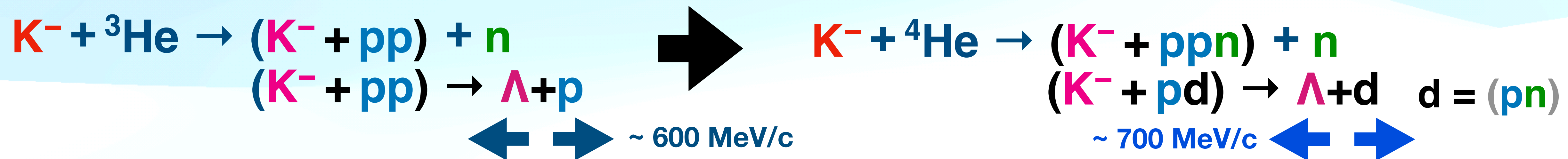

Preliminary data analysis for $\bar{K}NNN$ formation study utilizing ${}^4_{\Lambda}\text{He}$ lifetime measurement via $K^- + {}^4\text{He} \rightarrow \pi^0 + {}^4_{\Lambda}\text{He}$ reaction giving us a very interesting result

$K^- 4\text{He} \rightarrow \{\Lambda d\} + n$ Analysis (with the T77 Data)

Promising signal is observed!

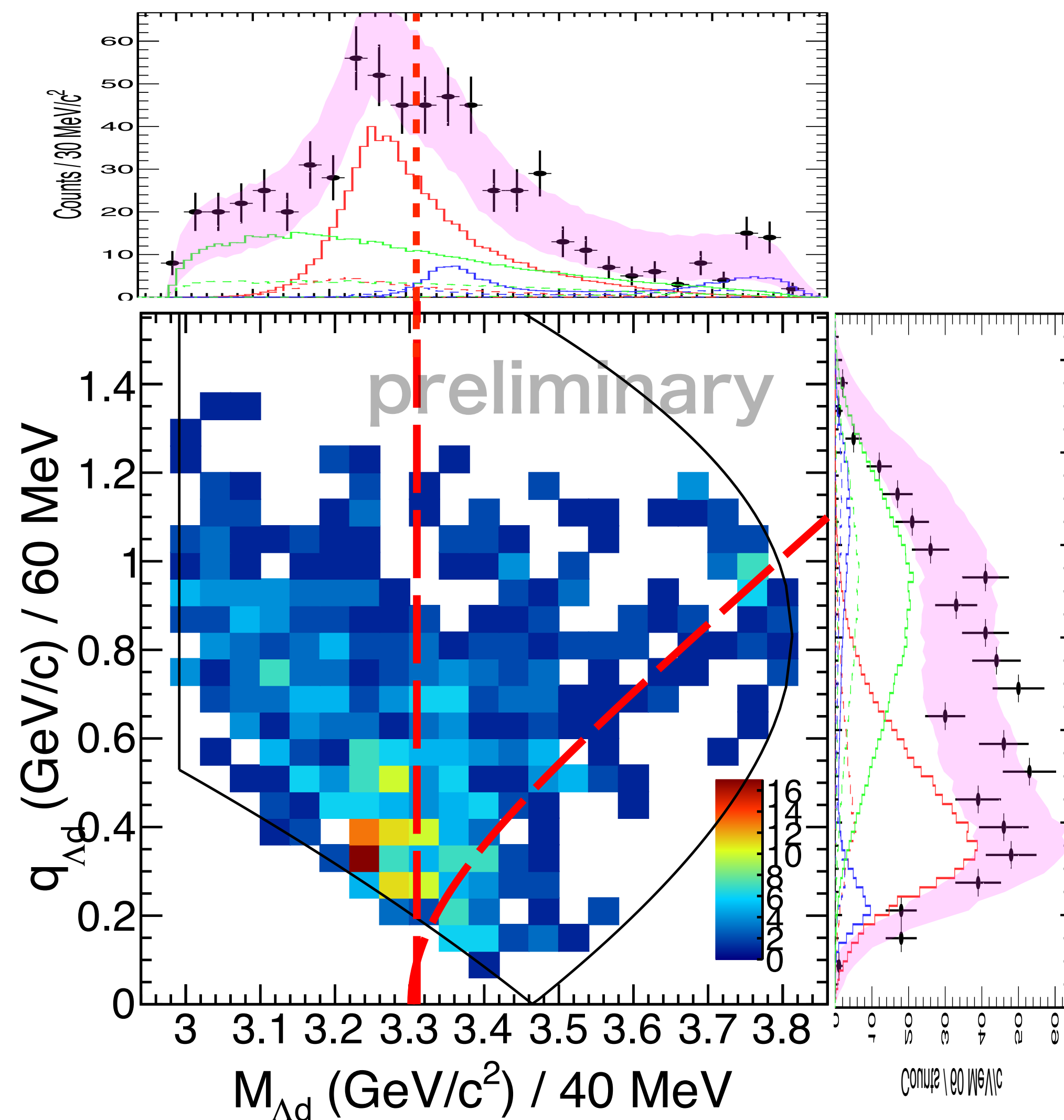

$K^- {}^4\text{He} \rightarrow \{\Lambda d\} + n$ Analysis (with the T77 Data)

Promising signal is observed!

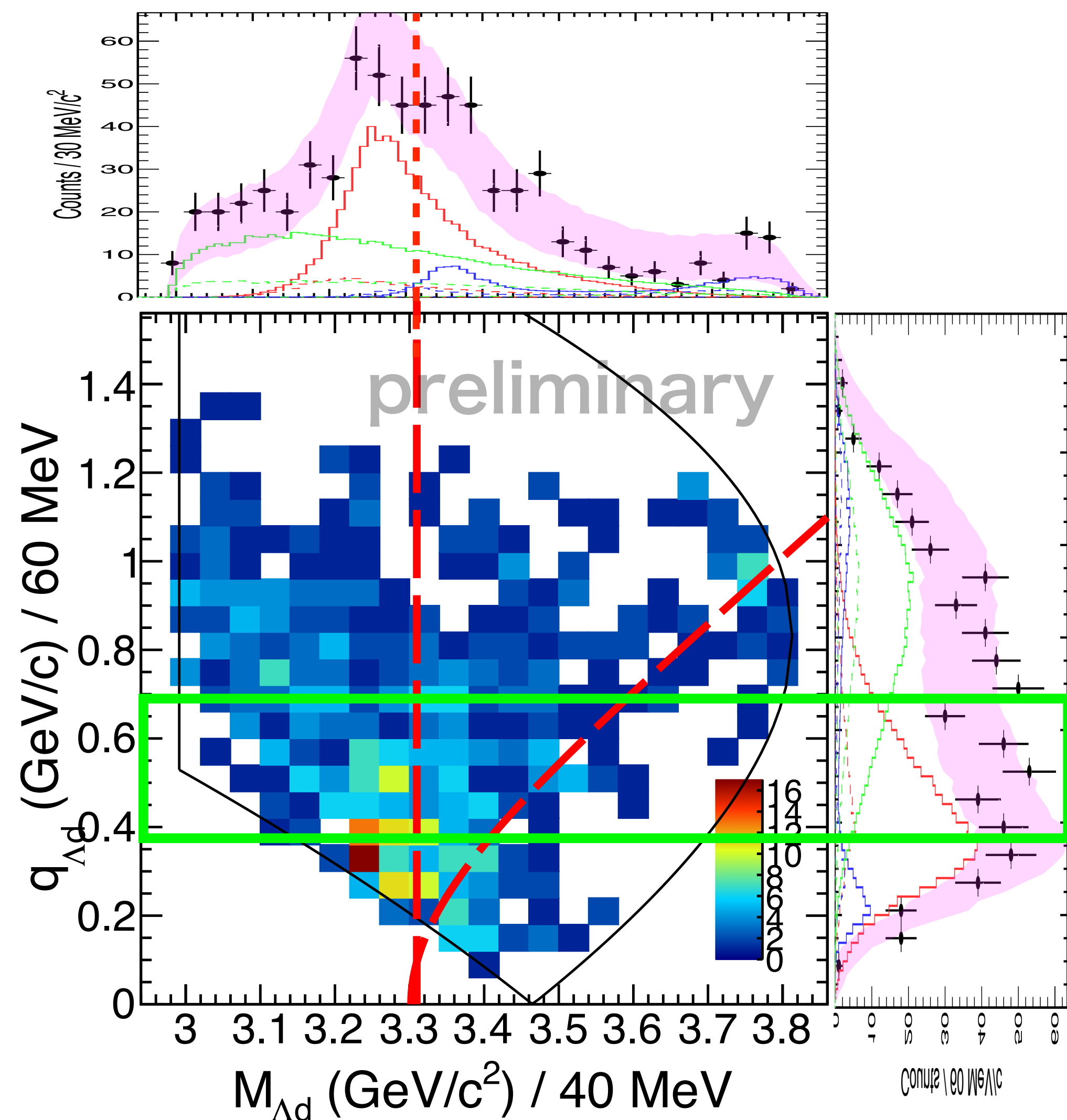

$0.3 < q_{\Lambda d} < 0.6$
GeV/c window

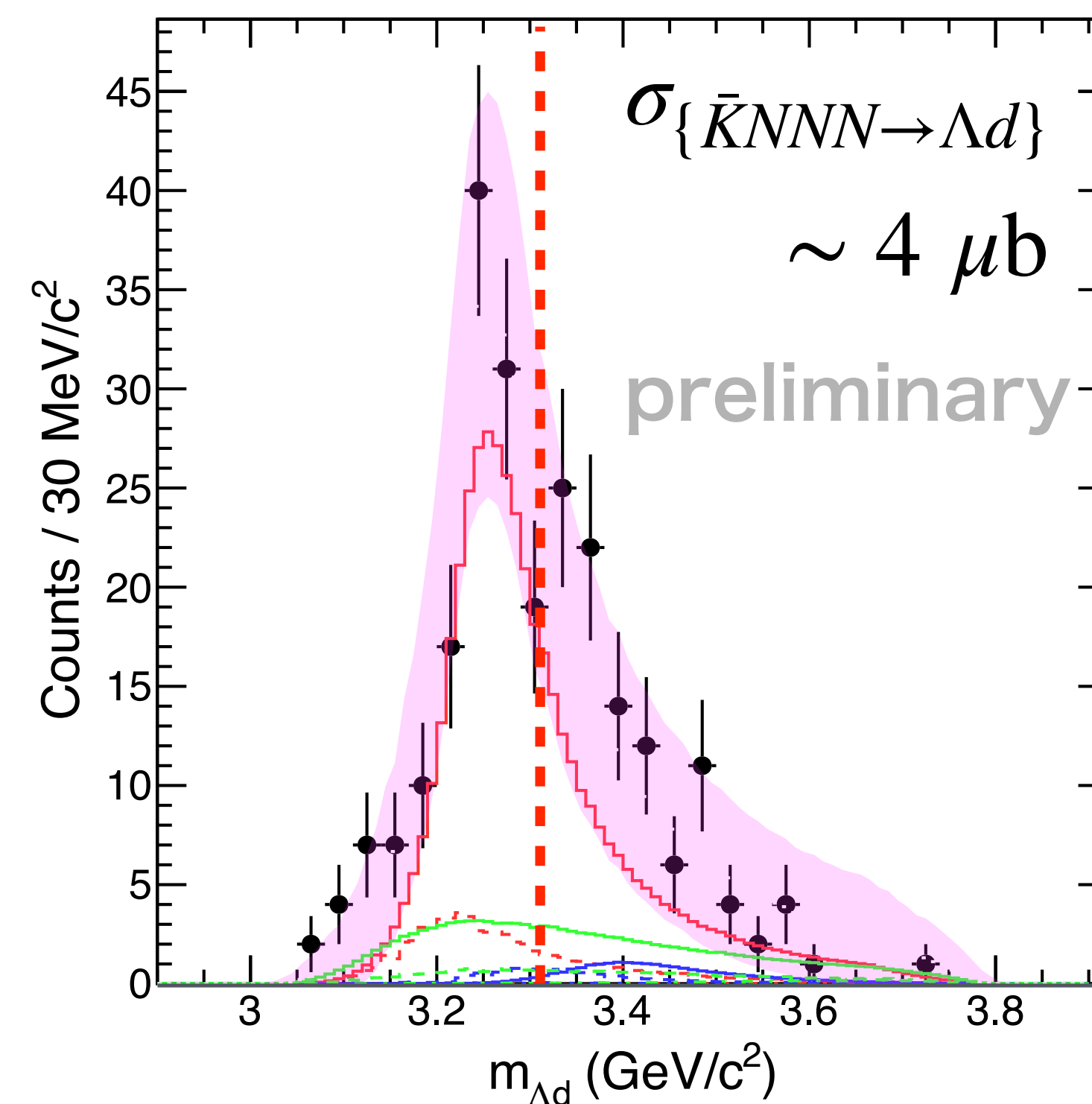

$K^- {}^4\text{He} \rightarrow \{\Lambda d\} + n$ Analysis (with the T77 Data)

Promising signal is observed! 1) *It suggests kaonic nuclei exist more universally, not just in cases like $K^- pp$.*

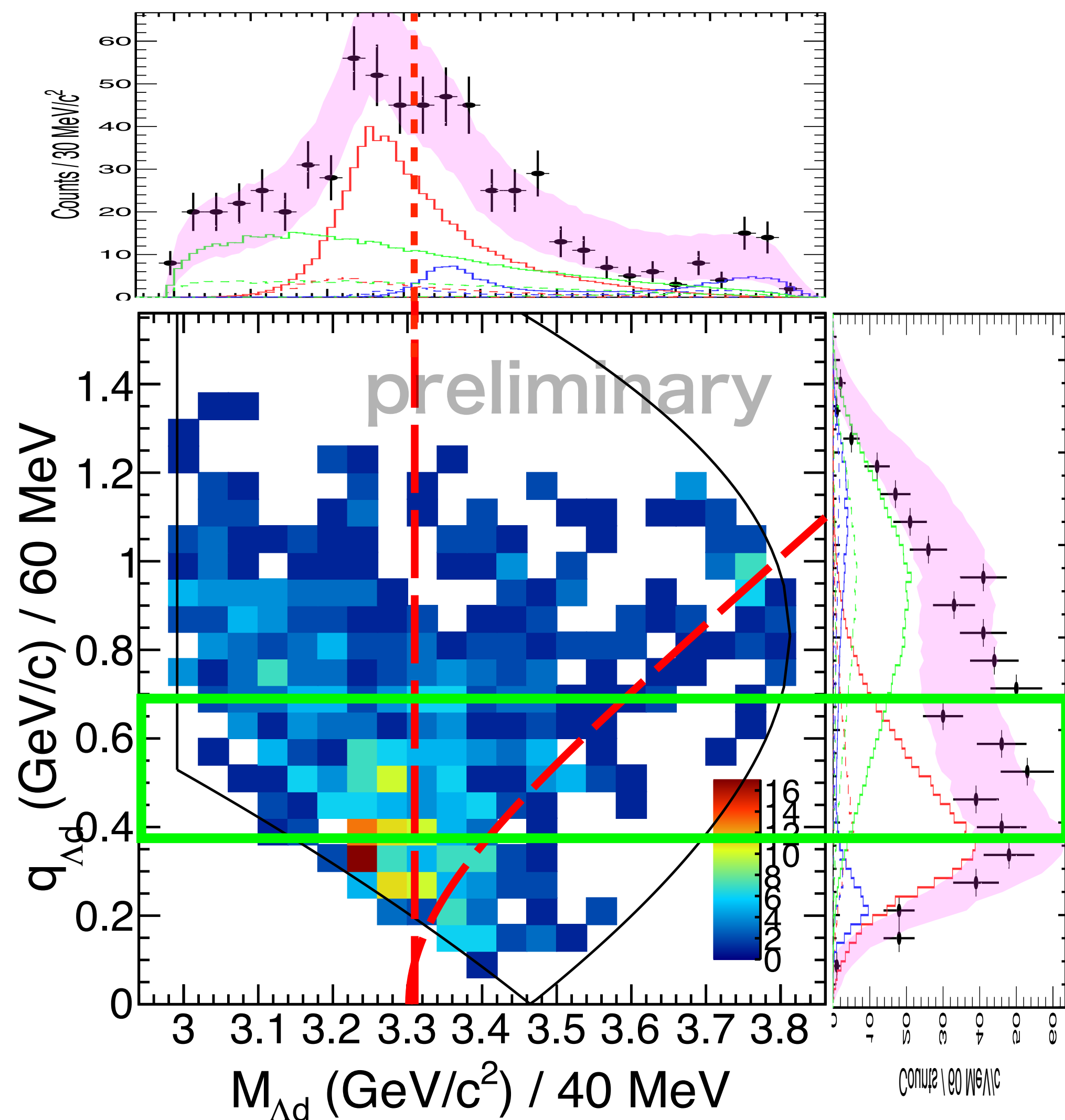

$0.3 < q_{\Lambda d} < 0.6$
GeV/c window

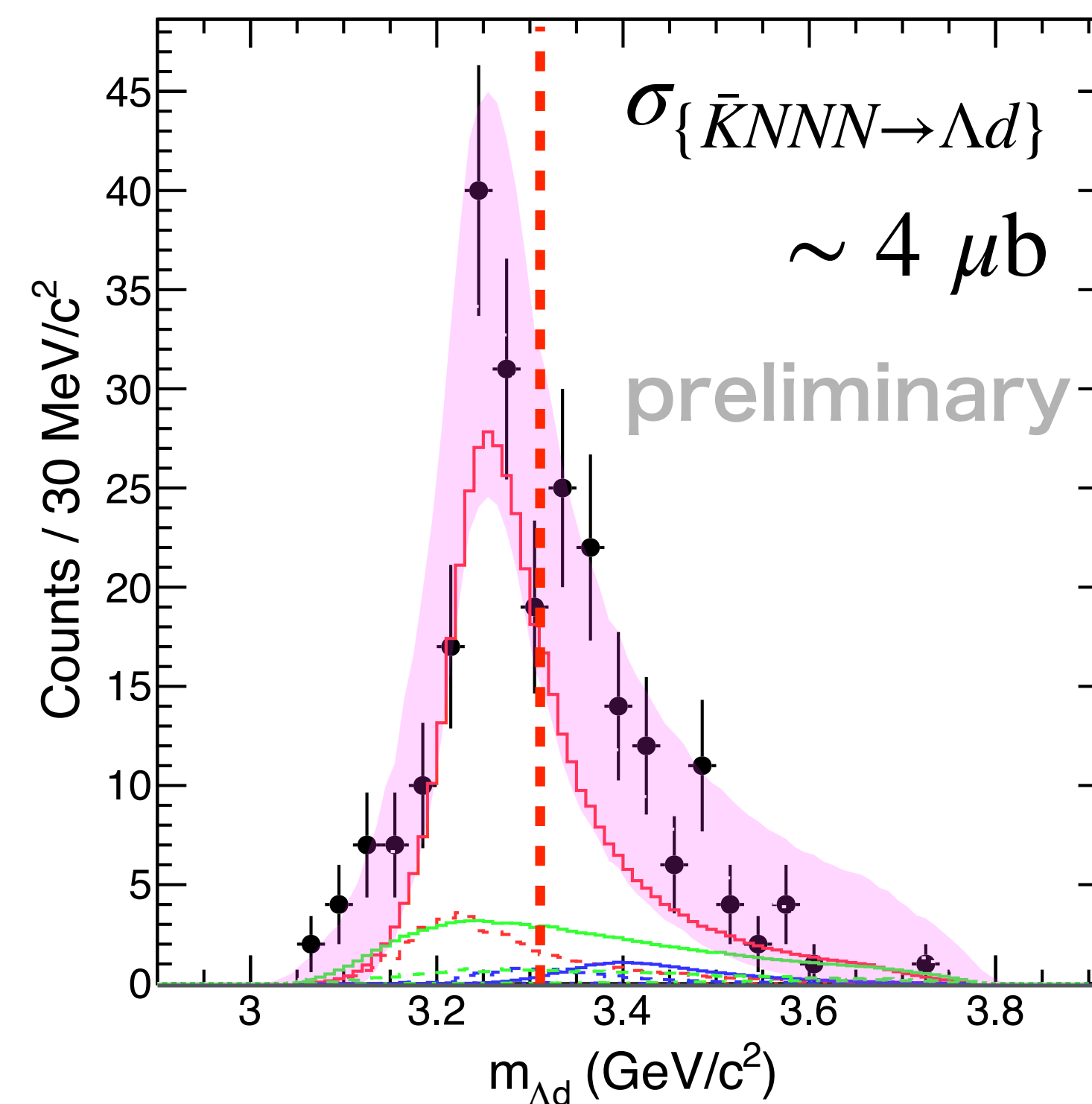

$K^- {}^4\text{He} \rightarrow \{\Lambda d\} + n$ Analysis (with the T77 Data)

- Promising signal is observed!**
- 1) It suggests kaonic nuclei exist more universally, not just in cases like $K^- pp$.
 - 2) Despite more nucleons absorbing the K meson, the width remains unchanged, suggesting a near plateau.

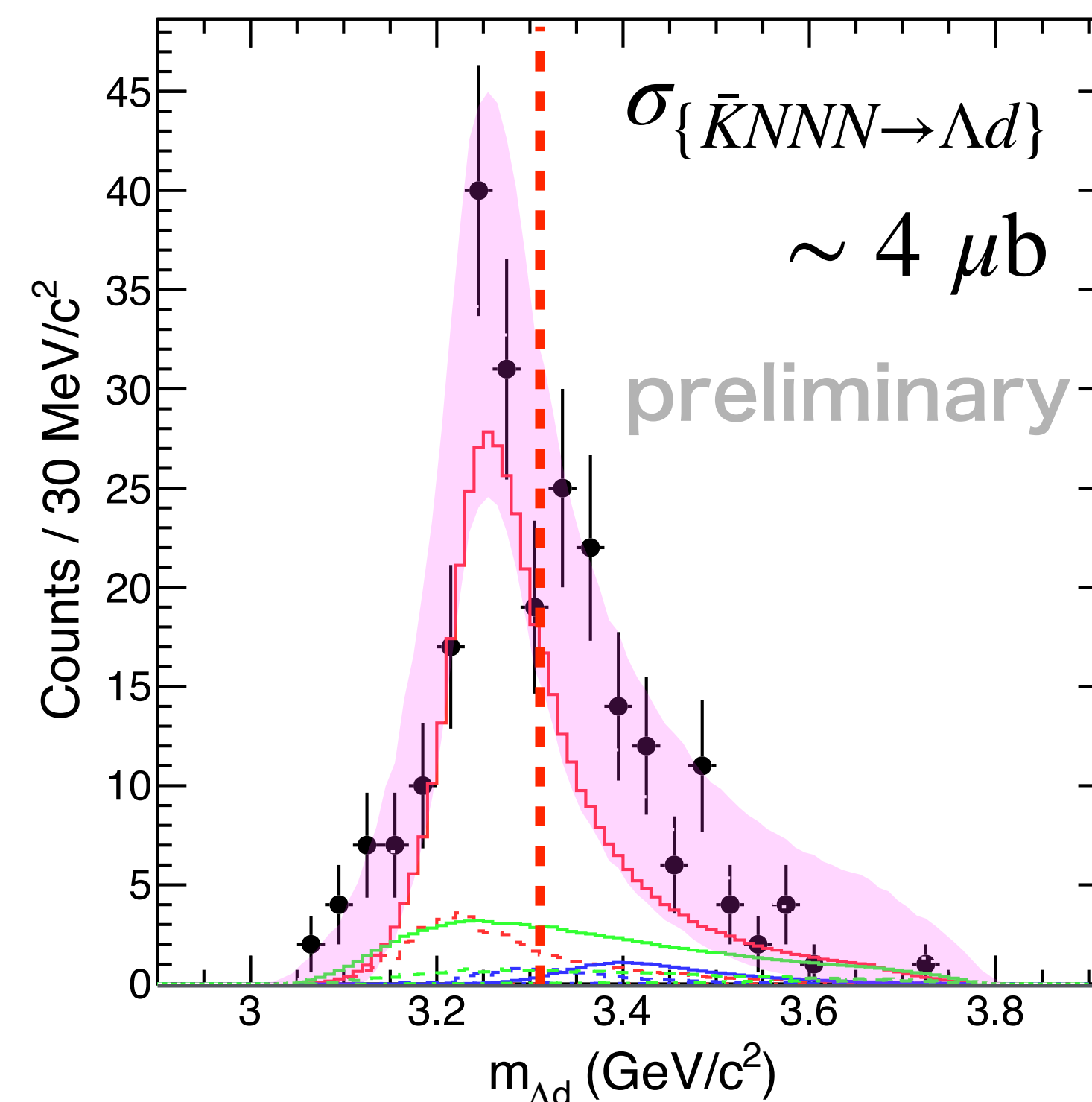
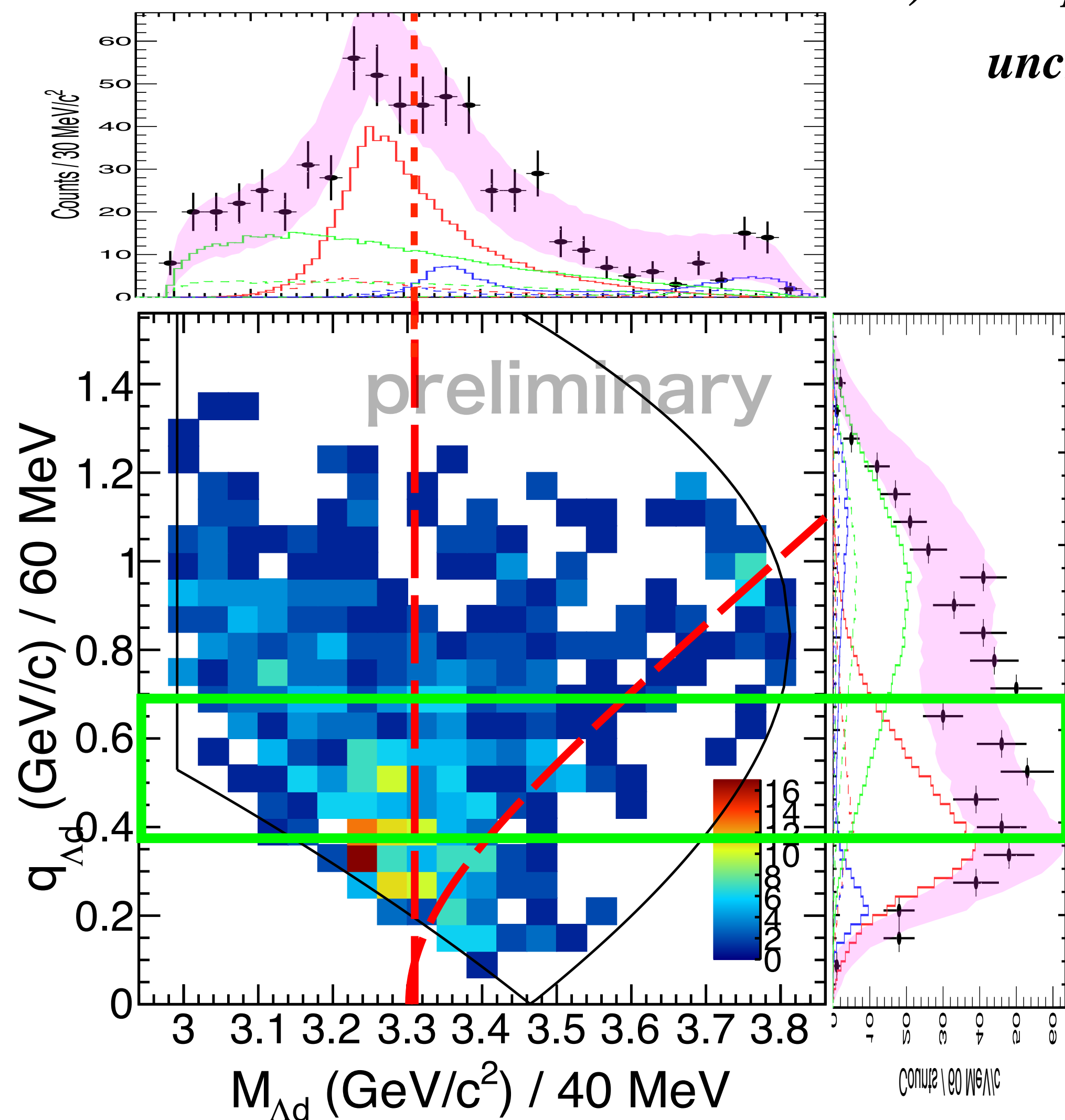

$K^- {}^4\text{He} \rightarrow \{\Lambda d\} + n$ Analysis (with the T77 Data)

Promising signal is observed!

- 1) It suggests kaonic nuclei exist more universally, not just in cases like $K^- pp$.
- 2) Despite more nucleons absorbing the K meson, the width remains unchanged, suggesting a near plateau.
- 3) In the case of $K^- ppn$, isospin and spin-parity $I(J^P)$, has been fixed to be $0(1/2^-)$ with high certainty through Λp decay.

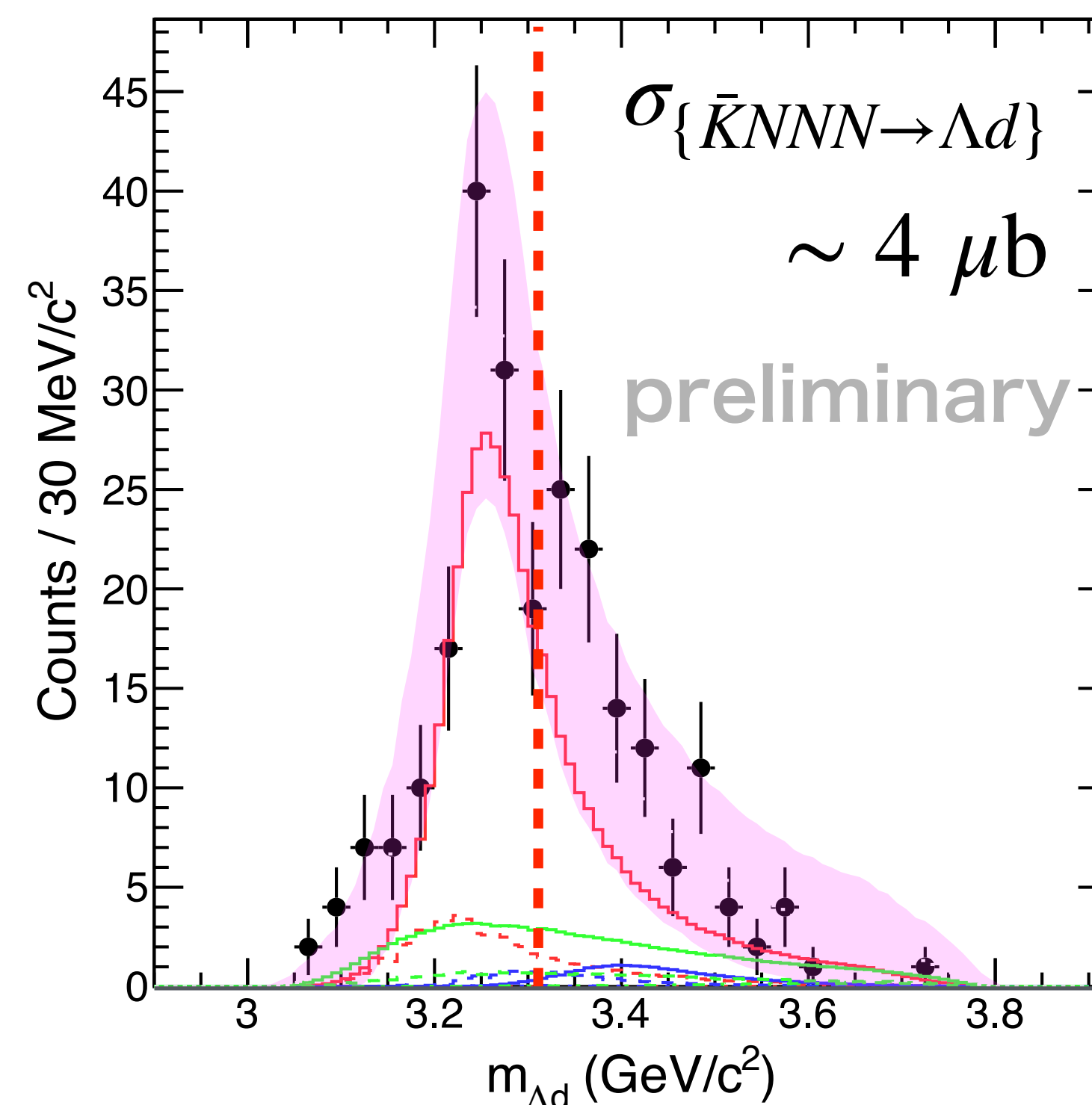
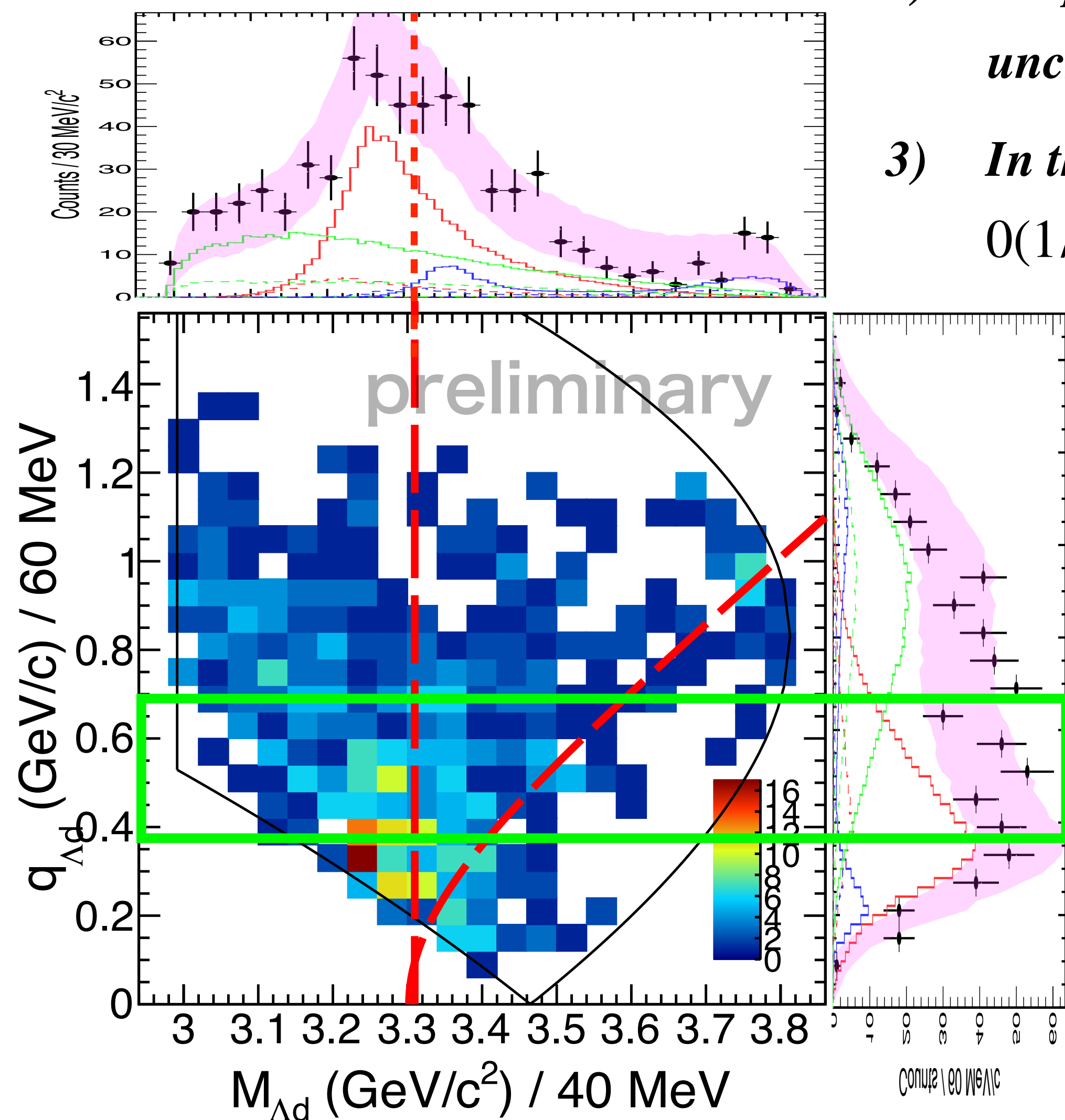

$I(J^P)$ of X in $K^- 4\text{He} \rightarrow X + n$

Why $I(J^P)$ of the state would be $0(1/2^-)$?

$\Lambda p n$ would be the major decay mode (relatively easily identified in this channel)

1. **“ X ” $\rightarrow \Lambda d$ decay mode is unique evidence of $I^{\text{“}X\text{”}} = 0$**

- $I(J^P) : \Lambda = 0(1/2^+), d = 0(1^+), K^- = 1/2(0^-), {}^3\text{He} = 1/2(1/2^+), {}^4\text{He} = 0(0^+)$

$I(J^P)$ of X in $K^- 4\text{He} \rightarrow X + n$

Why $I(J^P)$ of the state would be $0(1/2^-)$?

Λpn would be the major decay mode (relatively easily identified in this channel)

- “ X ” $\rightarrow \Lambda d$ decay mode is unique evidence of $I(J^P) = 0$

 - $I(J^P) : \Lambda = 0(1/2^+), d = 0(1^+), K^- = 1/2(0^-), {}^3\text{He} = 1/2(1/2^+), {}^4\text{He} = 0(0^+)$
- If “ X ” = “ $K^- ppn$ ”, J should be $J_{Kppn} = 1/2$, because J_{NNN} must be $1/2$ (two nucleons out of three are identical).

 - Most likely, it is “ X ” = “ $K^- ppn$ ”, in which \bar{K} 's isospin anti-parallel coupling with NNN [$I(J) = 1/2(1/2)$] in S-wave
 - Difficult to interpret as $\Sigma^* NN$: 1) spin/isospin of NN [$I(J) = 1(0)$] part must flip to form deuteron [$I(J) = 0(1)$] without breaking the NN pair, while 2) the energy release of $\Sigma^* N \rightarrow \Lambda N$ is much bigger than the binding energy of d .

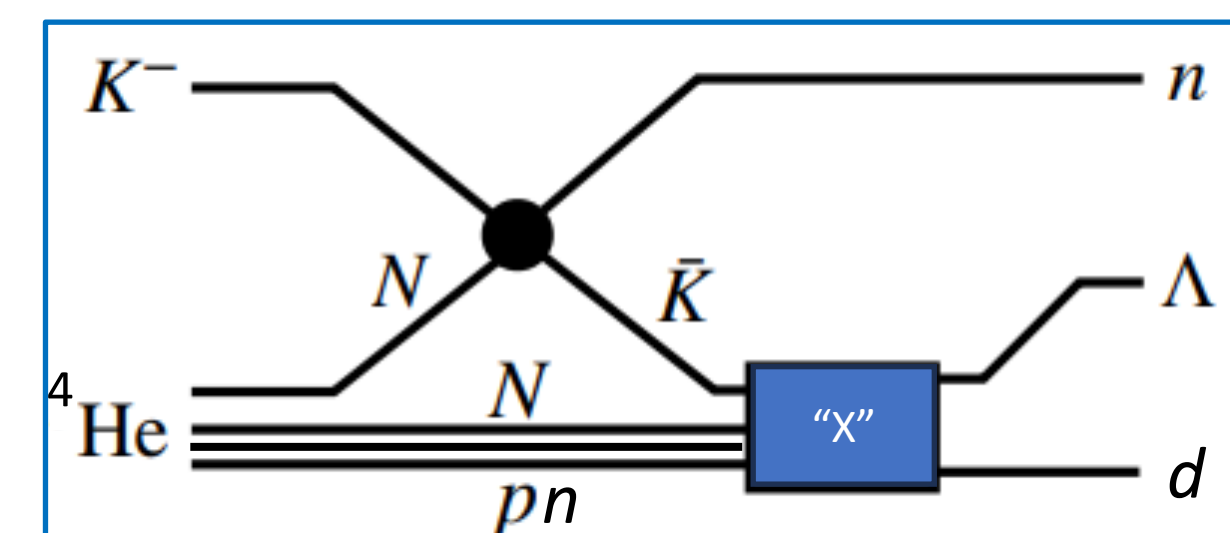
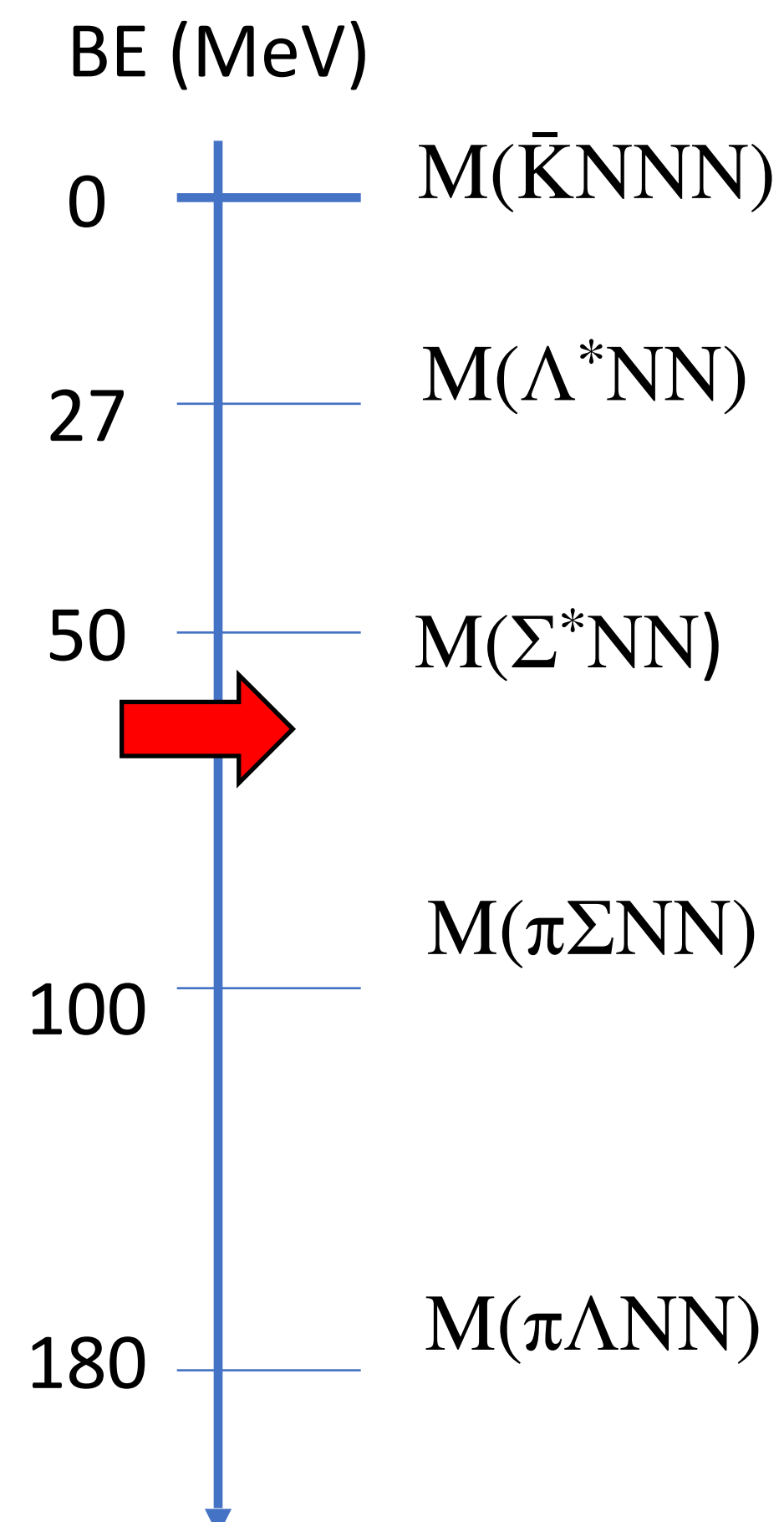

Size of $\bar{K}NNN$ via Data?

One nucleon \bar{K} absorption ($1N_{\bar{K}A}$):

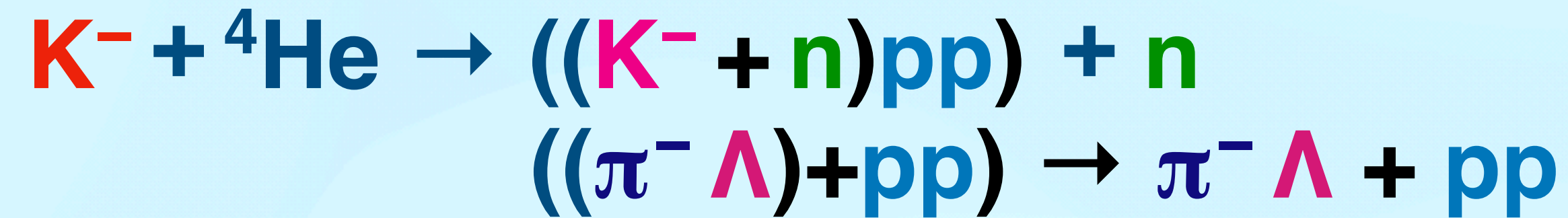

Two nucleon \bar{K} absorption ($2N_{\bar{K}A}$):

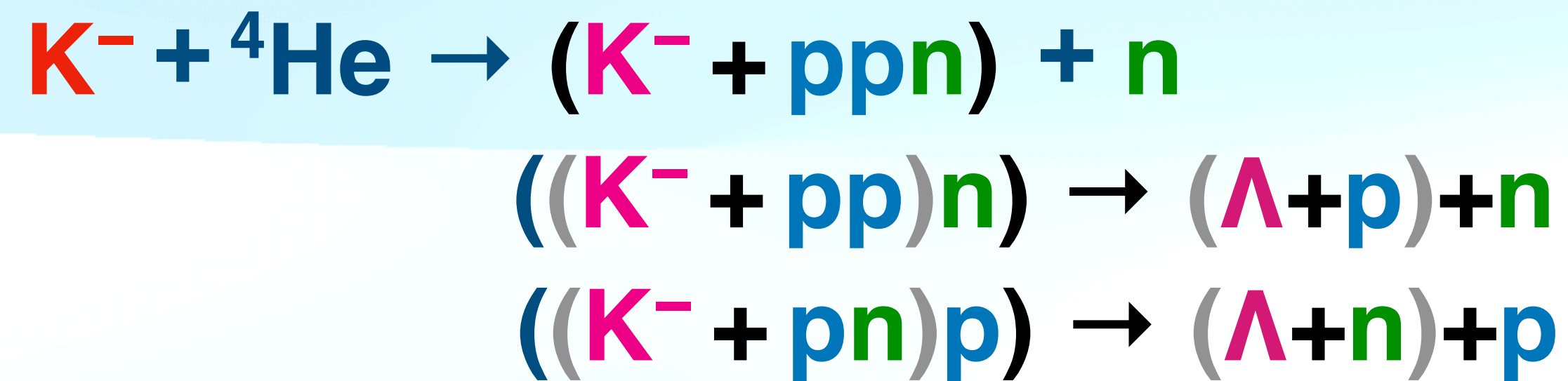

Three nucleon \bar{K} absorption ($3N_{\bar{K}A}$):

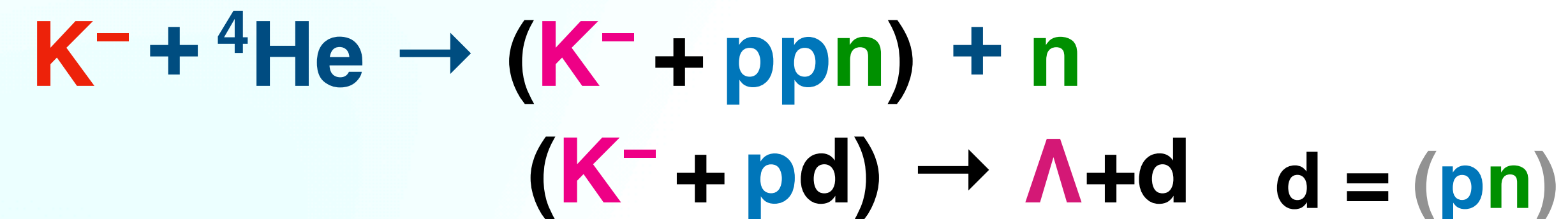

Size of $\bar{K}NNN$ via Data?

One nucleon \bar{K} absorption ($1N_{\bar{K}A}$):

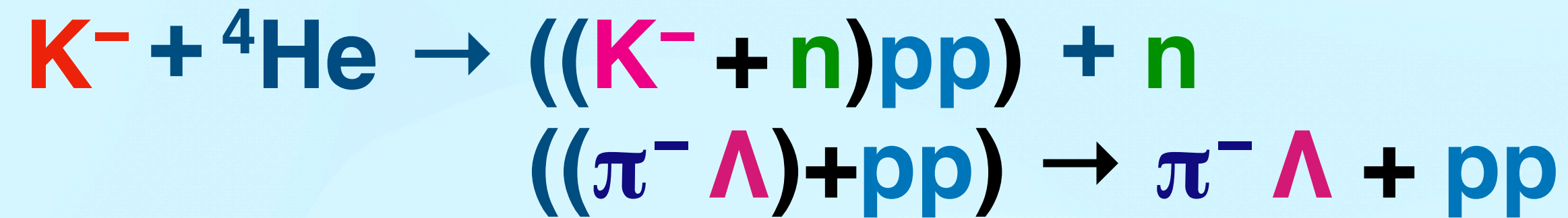

Two nucleon \bar{K} absorption ($2N_{\bar{K}A}$):

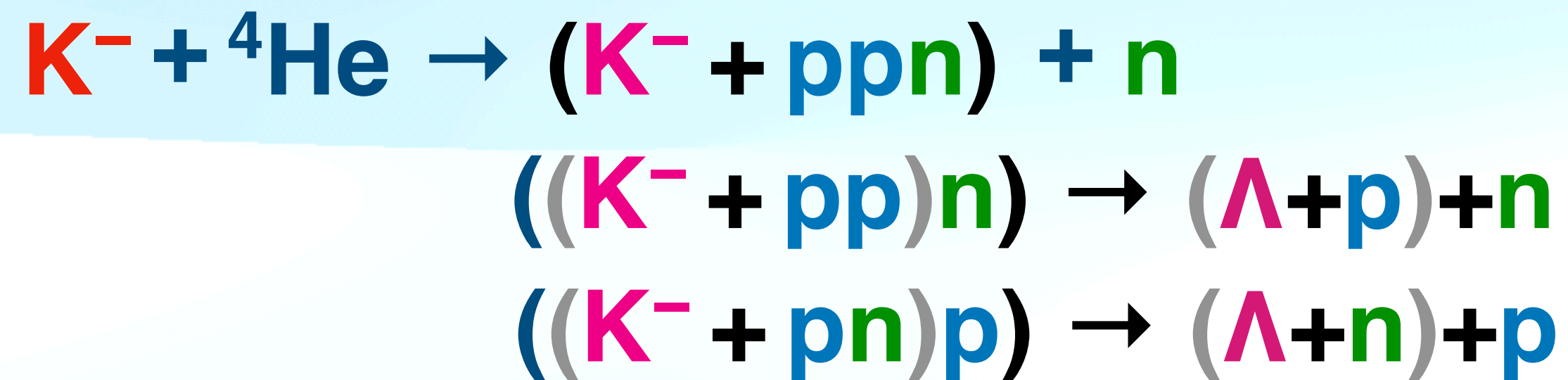

Three nucleon \bar{K} absorption ($3N_{\bar{K}A}$):

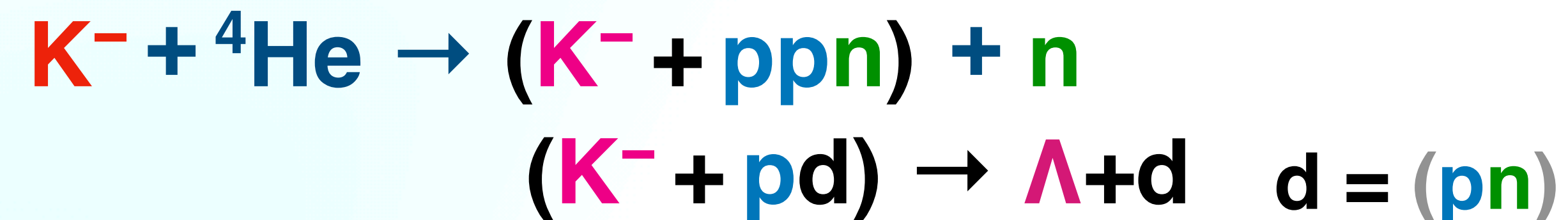

The ratio of the three nucleon processes would be sensitive to the core size.

$$1N_{\bar{K}A} : 2N_{\bar{K}A} : 3N_{\bar{K}A} \sim \rho_N : \rho_N^2 : \rho_N^3 ?$$

Theoretical inputs are needed.

Size of $\bar{K}NNN$ via Data?

One nucleon \bar{K} absorption ($1N_{\bar{K}A}$):

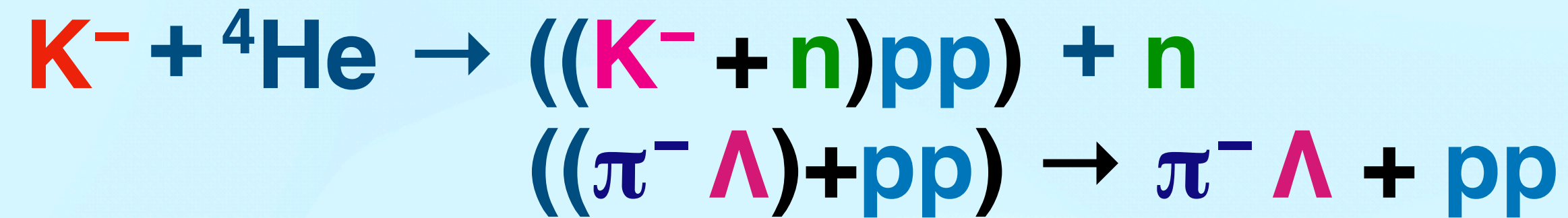

Two nucleon \bar{K} absorption ($2N_{\bar{K}A}$):

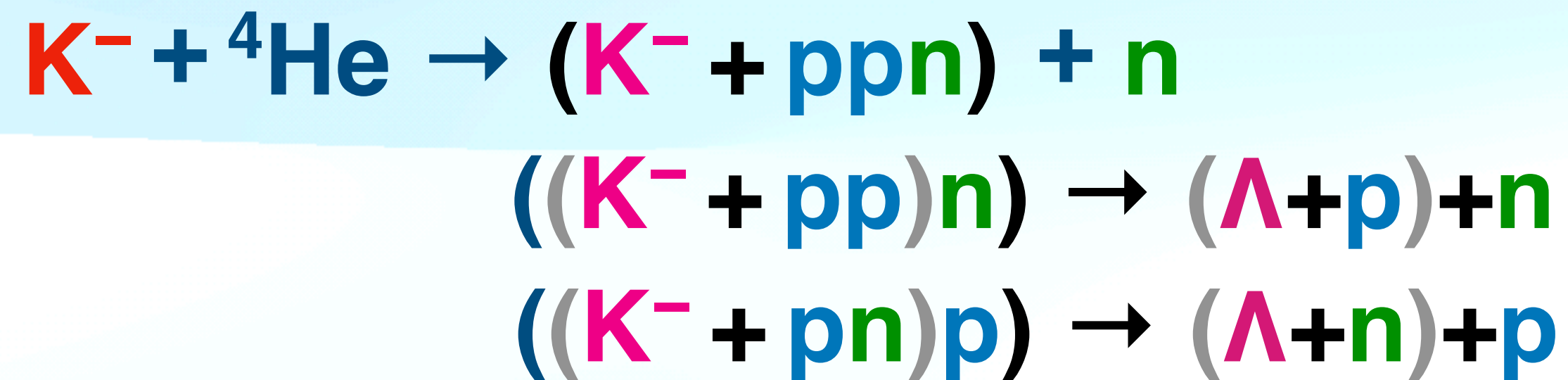

Three nucleon \bar{K} absorption ($3N_{\bar{K}A}$):

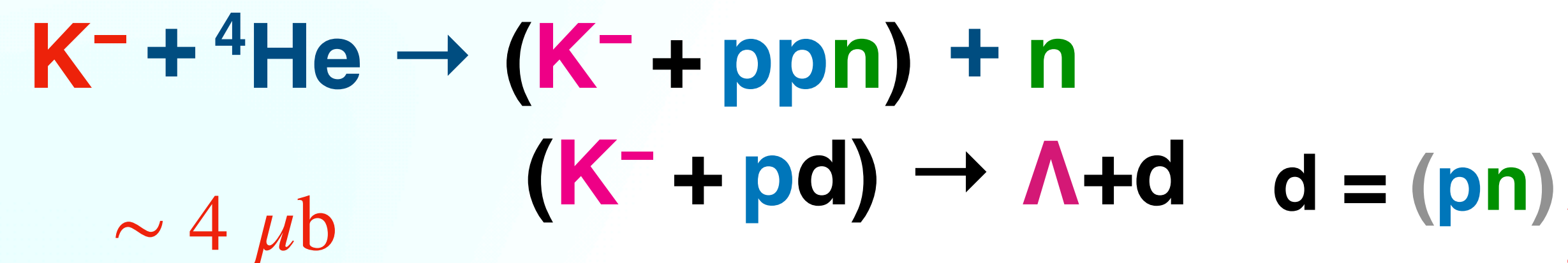

The ratio of the three nucleon processes would be sensitive to the core size.

$$1N_{\bar{K}A} : 2N_{\bar{K}A} : 3N_{\bar{K}A} \sim \rho_N : \rho_N^2 : \rho_N^3 ?$$

Theoretical inputs are needed.

Size of $\bar{K}NNN$ via Data?

One nucleon \bar{K} absorption ($1N_{\bar{K}A}$):

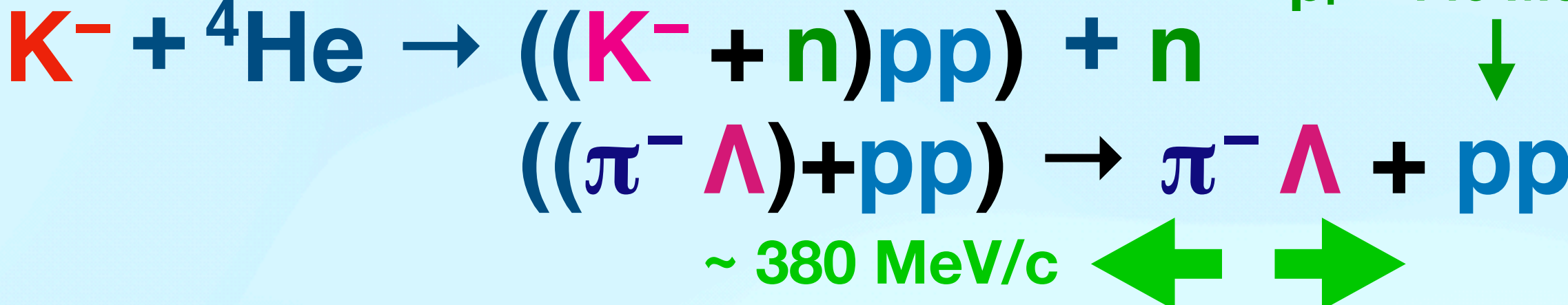

spectators
 $p_F \sim 140 \text{ MeV}/c$
 \downarrow

The ratio of the three nucleon processes would be sensitive to the core size.

$$1N_{\bar{K}A} : 2N_{\bar{K}A} : 3N_{\bar{K}A} \sim \rho_N : \rho_N^2 : \rho_N^3 ?$$

Theoretical inputs are needed.

Two nucleon \bar{K} absorption ($2N_{\bar{K}A}$):

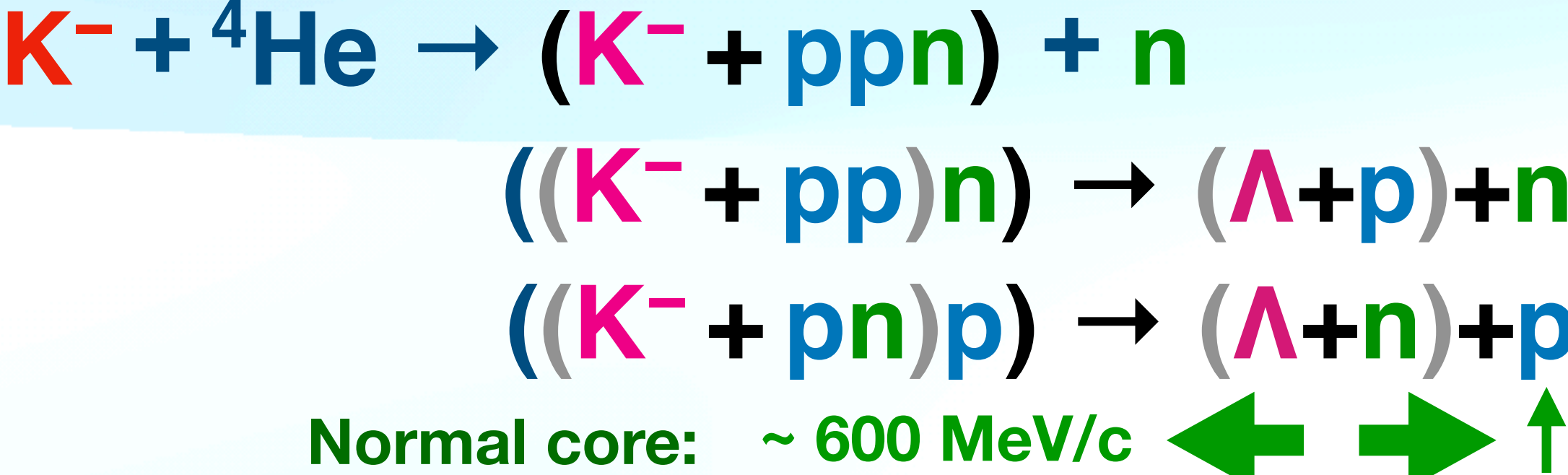

spectators
 $p_F \sim 140 \text{ MeV}/c$

Dalitz plots

Normal core:

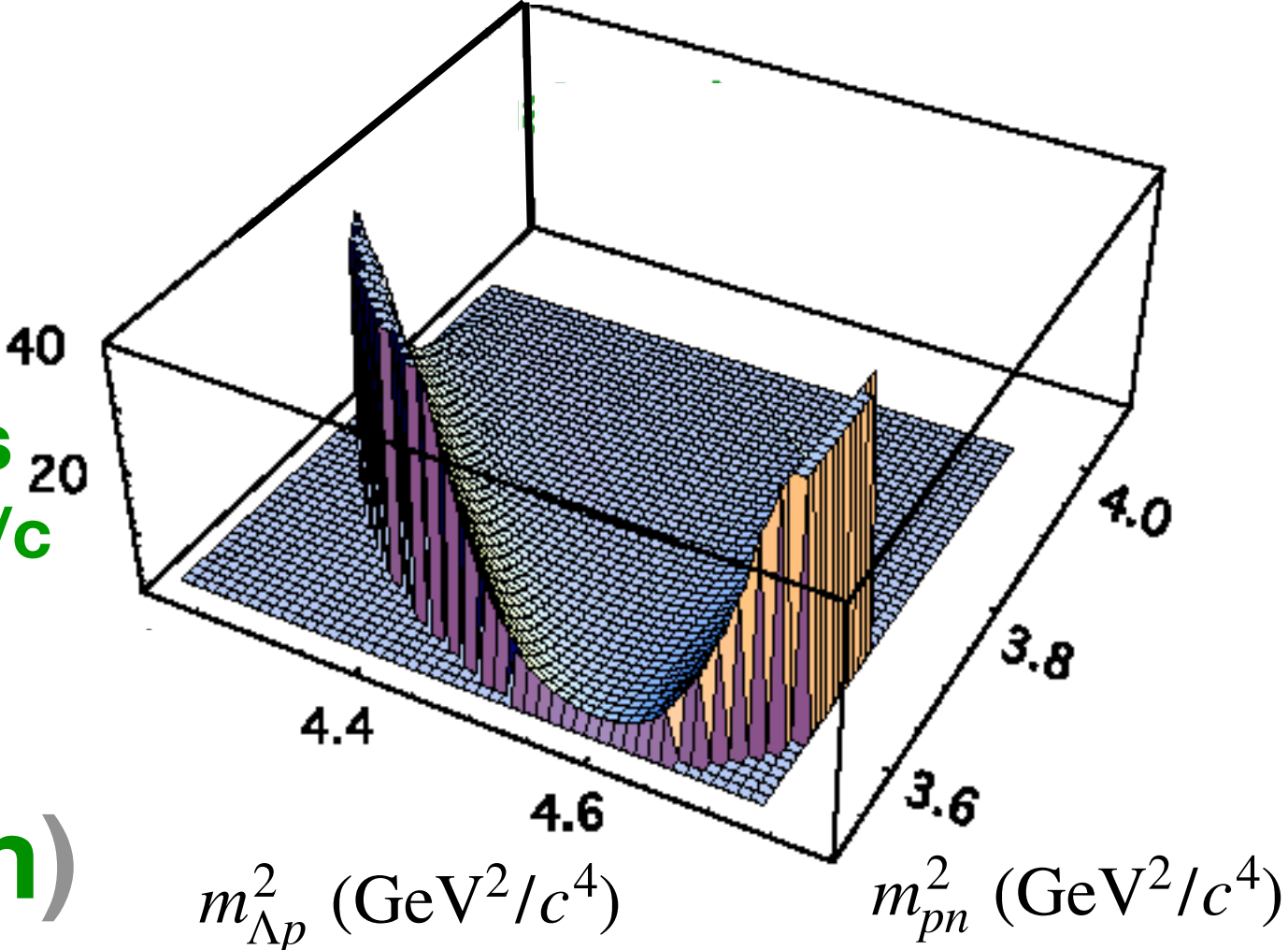

Three nucleon \bar{K} absorption ($3N_{\bar{K}A}$):

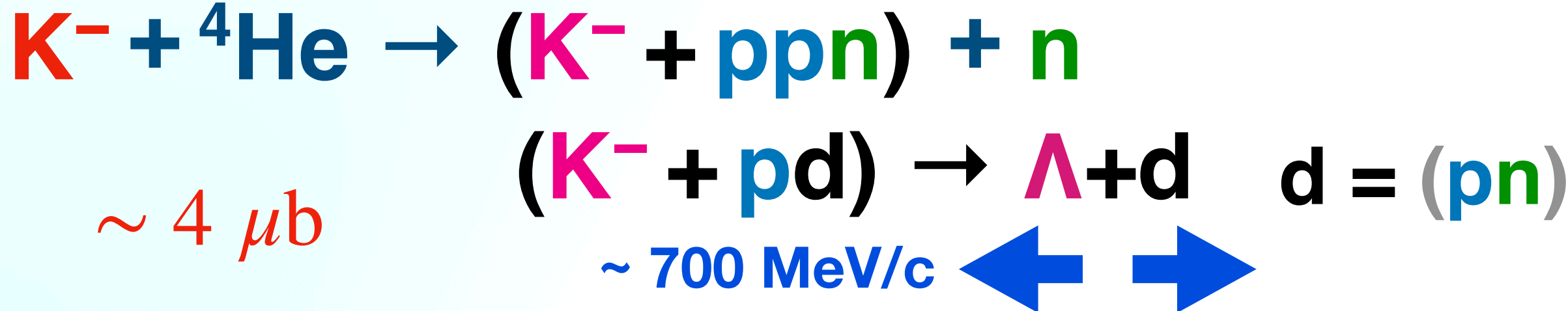

$\sim 4 \mu\text{b}$

Size of $\bar{K}NNN$ via Data?

One nucleon \bar{K} absorption ($1N_{\bar{K}A}$):

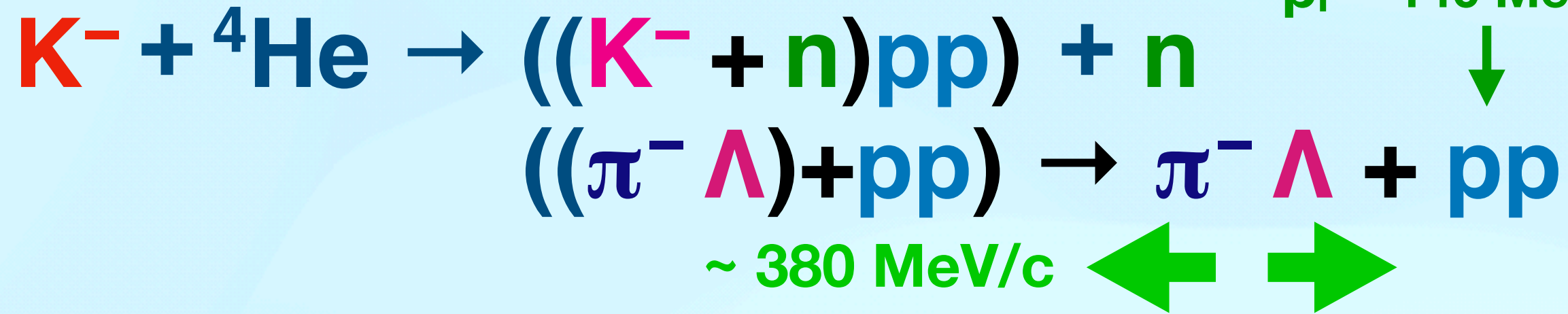

The ratio of the three nucleon processes would be sensitive to the core size.

$$1N_{\bar{K}A} : 2N_{\bar{K}A} : 3N_{\bar{K}A} \sim \rho_N : \rho_N^2 : \rho_N^3 ?$$

Theoretical inputs are needed.

Two nucleon \bar{K} absorption ($2N_{\bar{K}A}$):

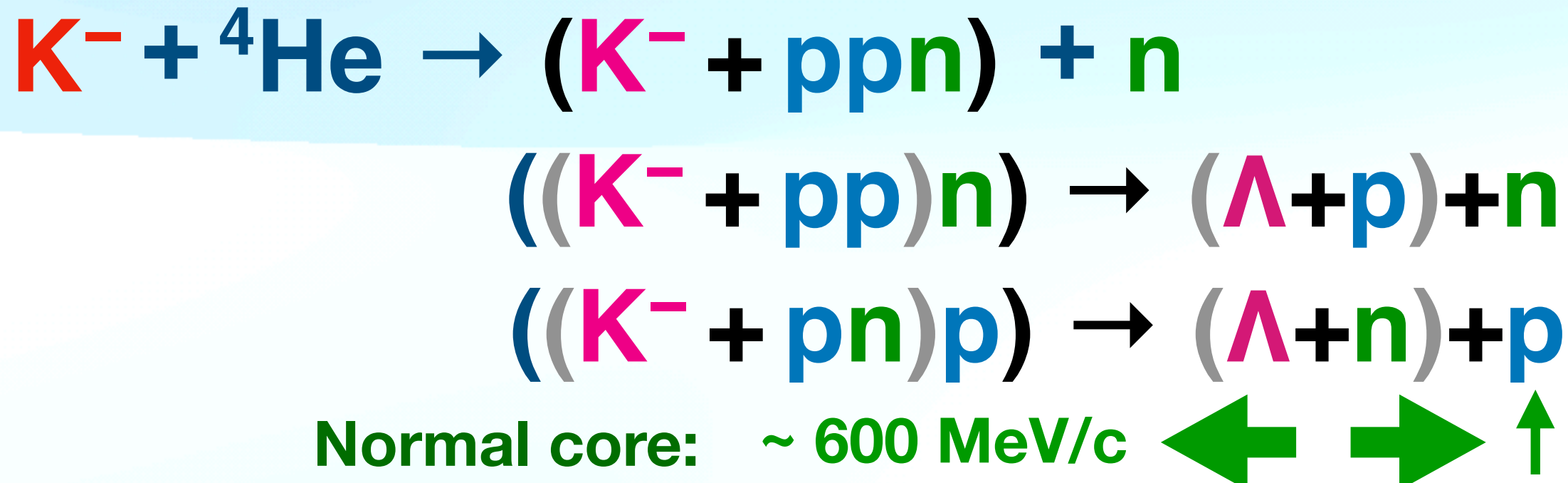

Dalitz plots

Three nucleon \bar{K} absorption ($3N_{\bar{K}A}$):

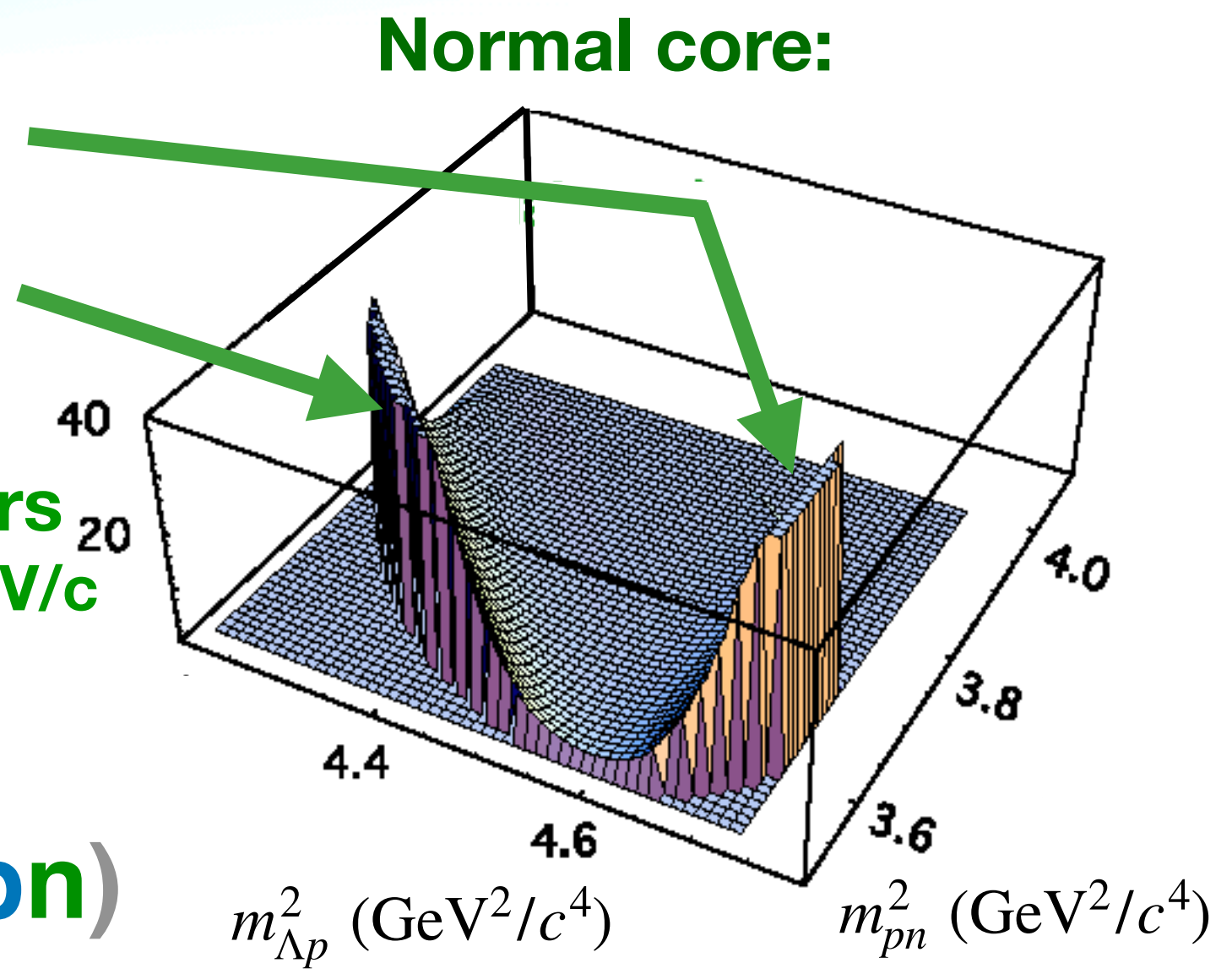
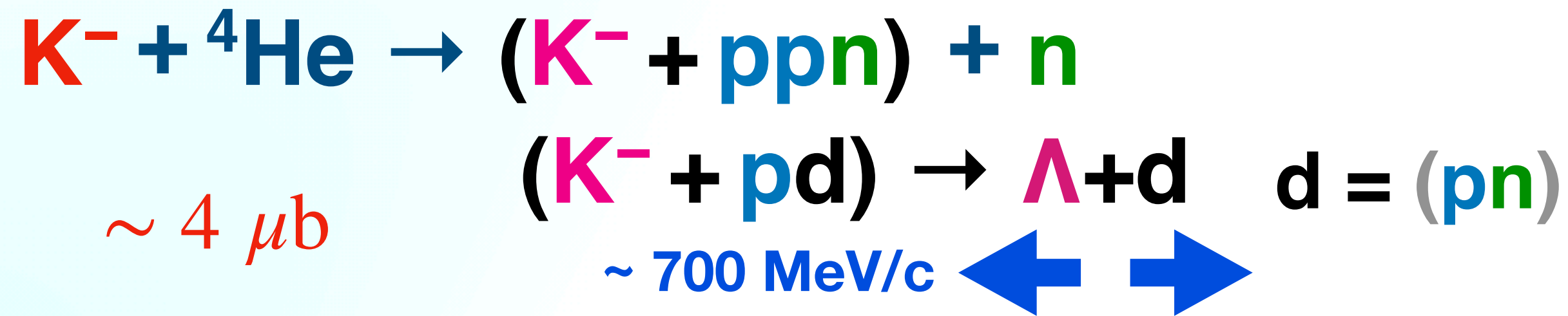

Size of $\bar{K}NNN$ via Data?

One nucleon \bar{K} absorption ($1N_{\bar{K}A}$):

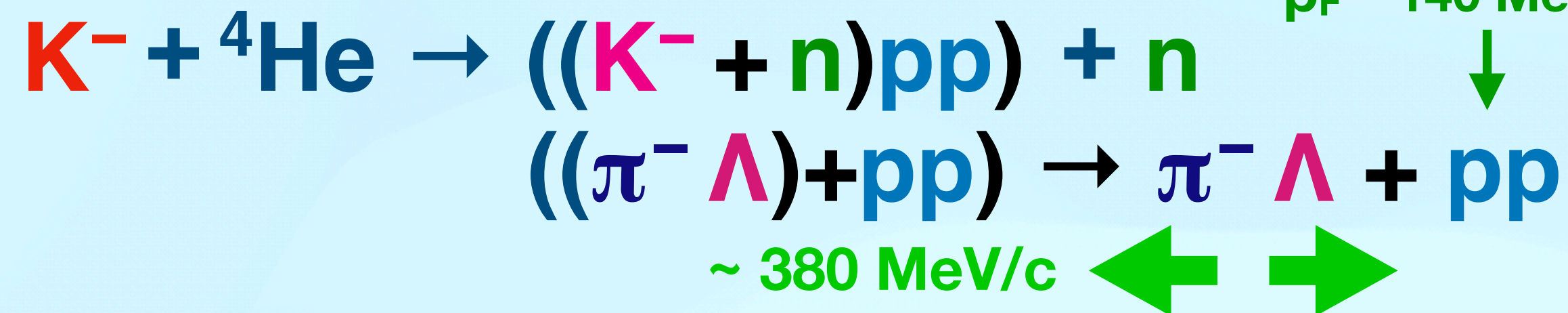

The ratio of the three nucleon processes would be sensitive to the core size.

$$1N_{\bar{K}A} : 2N_{\bar{K}A} : 3N_{\bar{K}A} \sim \rho_N : \rho_N^2 : \rho_N^3 ?$$

Theoretical inputs are needed.

Two nucleon \bar{K} absorption ($2N_{\bar{K}A}$):

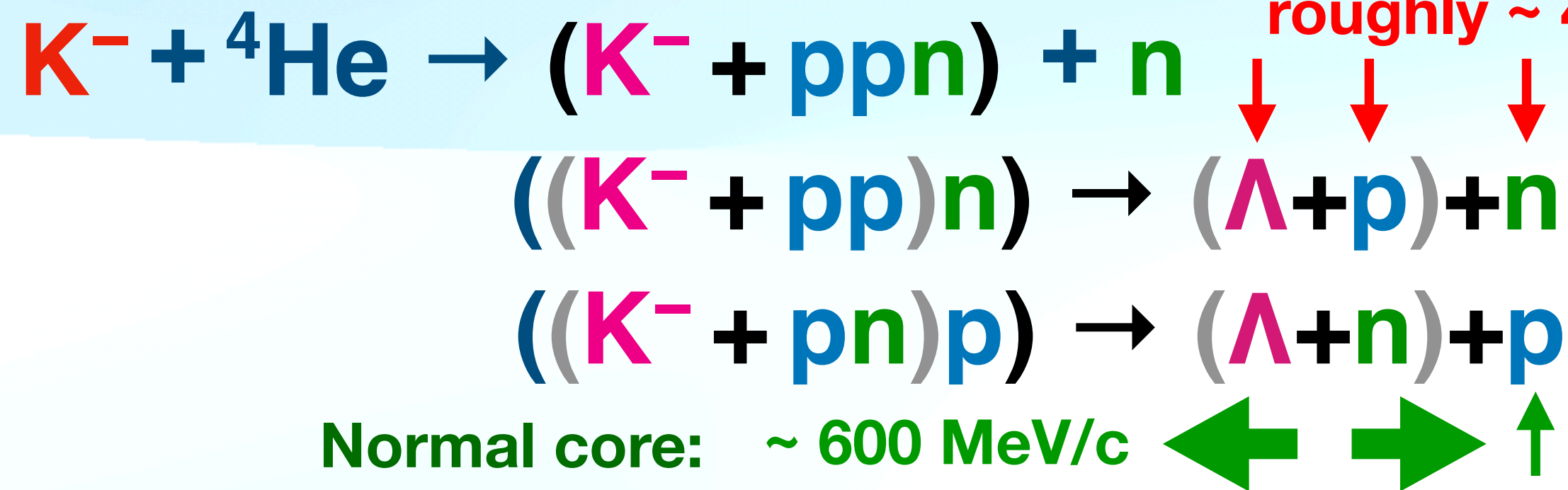

Dalitz plots

Compact core:

Three nucleon \bar{K} absorption ($3N_{\bar{K}A}$):

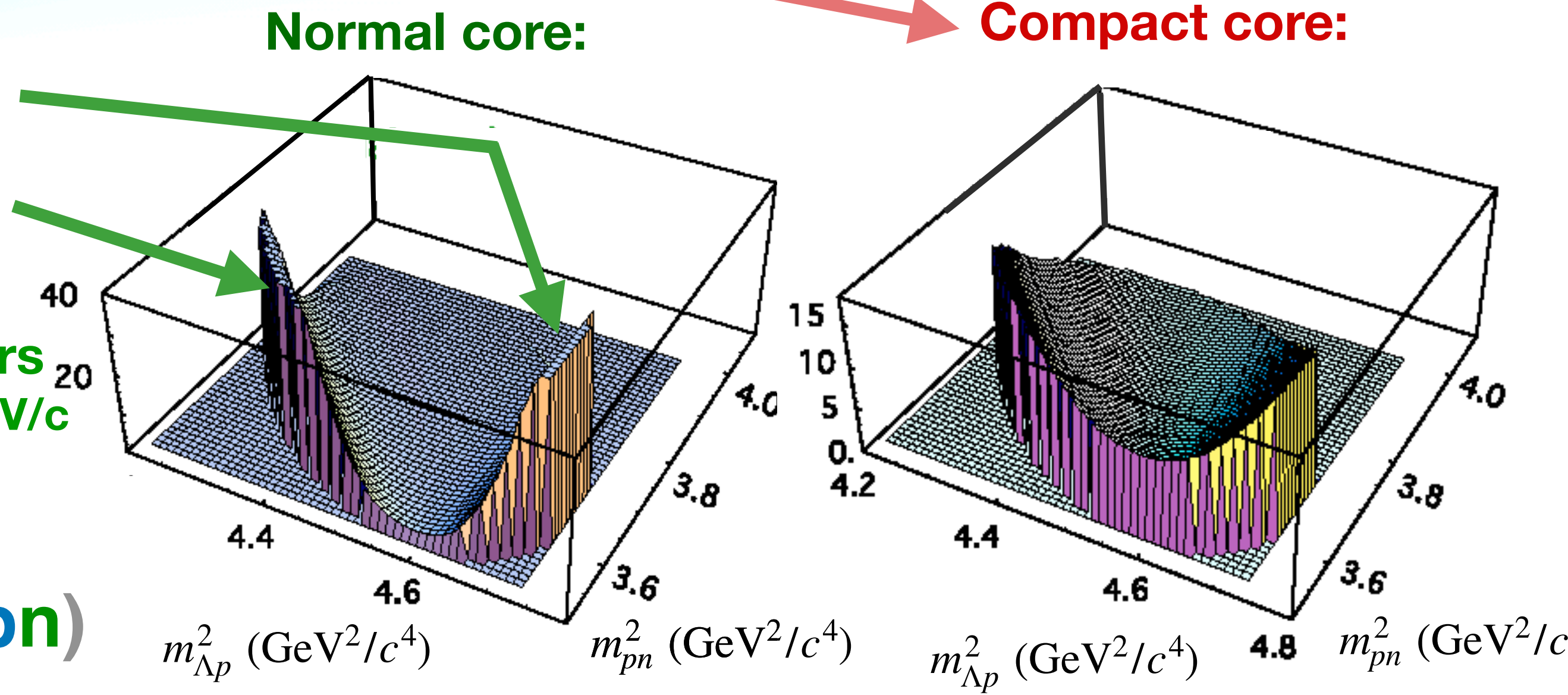
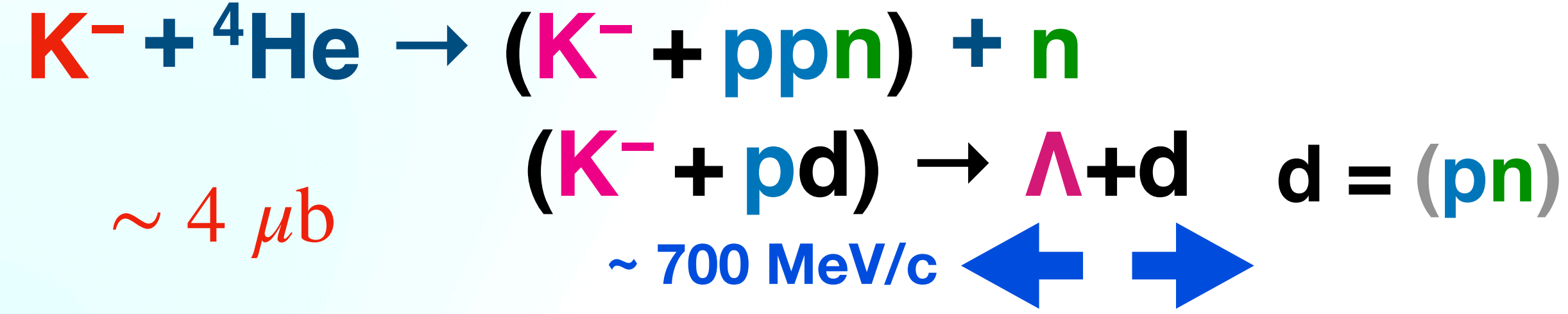

Toward next generation research — New Spectrometer —

Does Isospin-partner $(\bar{K}^0 nn)_{I_3 = -1/2}$ exist?

Are kaonic nuclei really compact?

Theoretical exploration of Kaonic Nuclei.

for the systematic study on

$(\sim 10^{-15} \text{ m})$

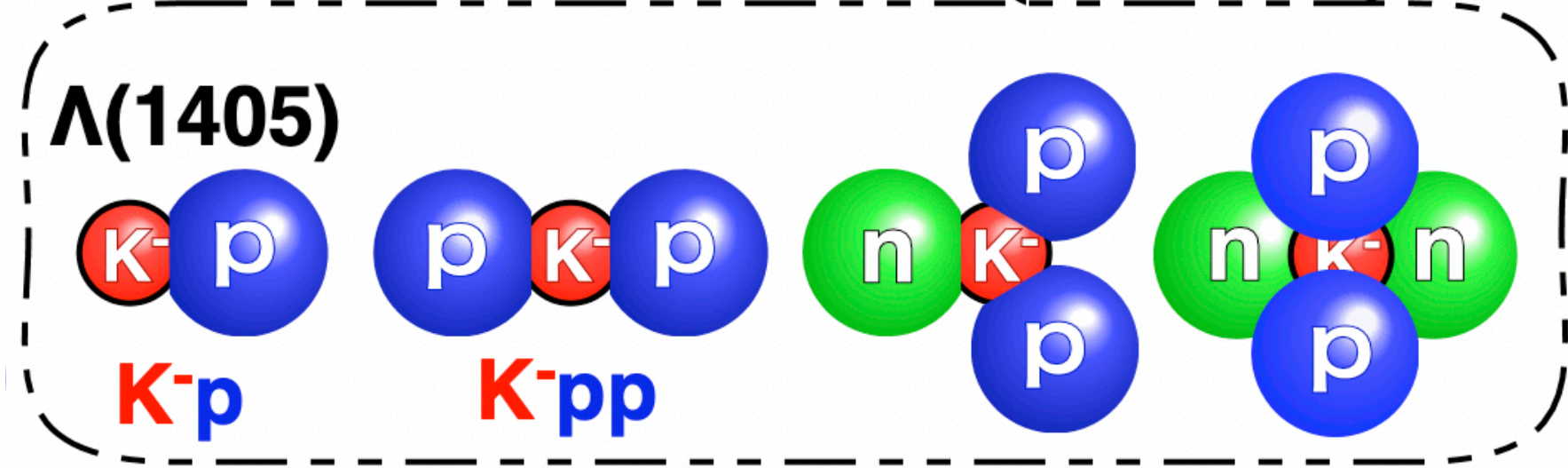

molecule-like hadronic nuclear cluster⁰

"Does it have a unique shape like a chemical molecule?"

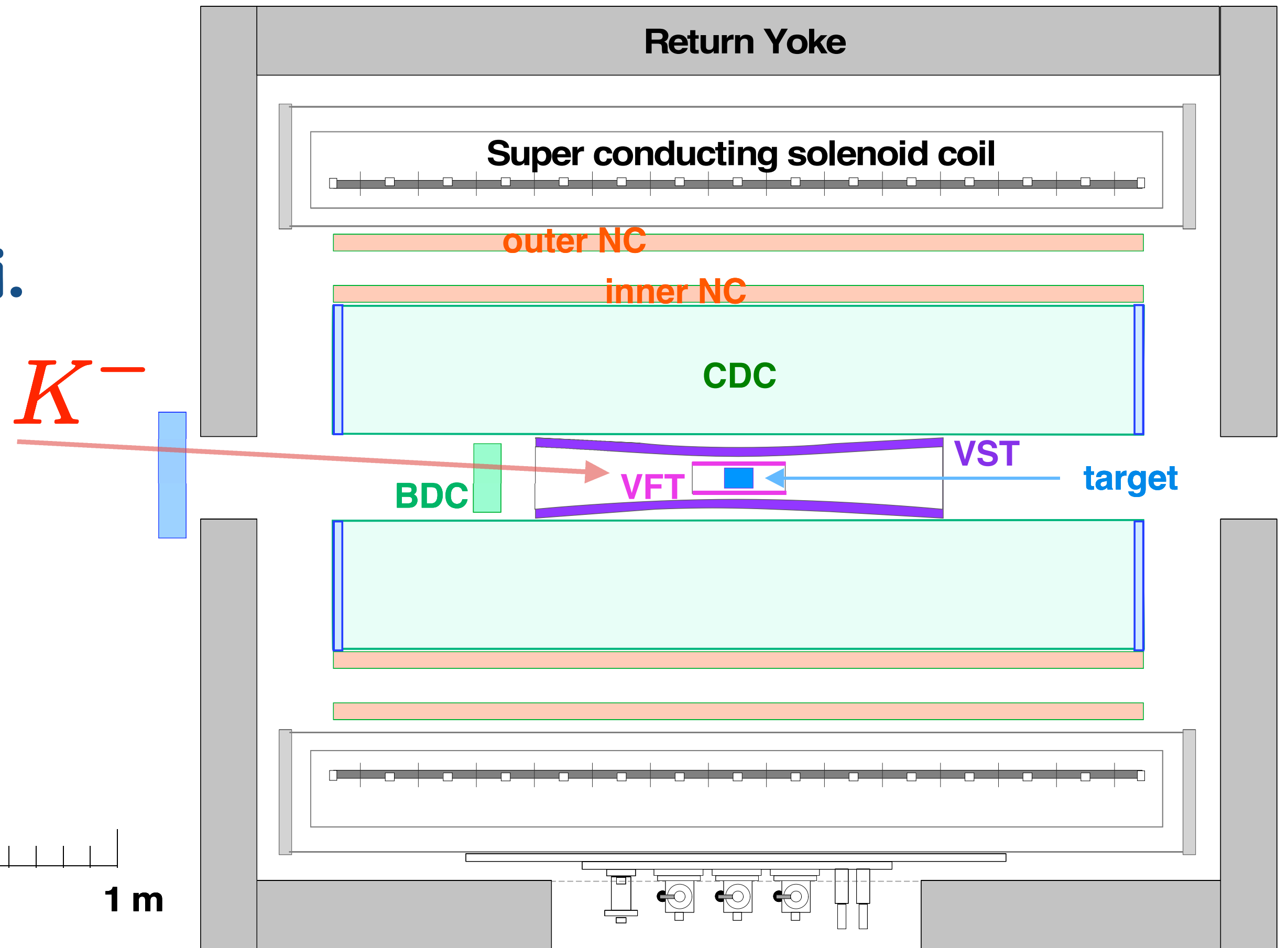

... Construction is in progress, led by *F. Sakuma* 16

Toward next generation research — New Spectrometer —

Does Isospin-partner $(\bar{K}^0 nn)_{I_3 = -1/2}$ exist?

Are kaonic nuclei really compact?

Theoretical exploration of Kaonic Nuclei.

for the systematic study on

$(\sim 10^{-15} \text{ m})$

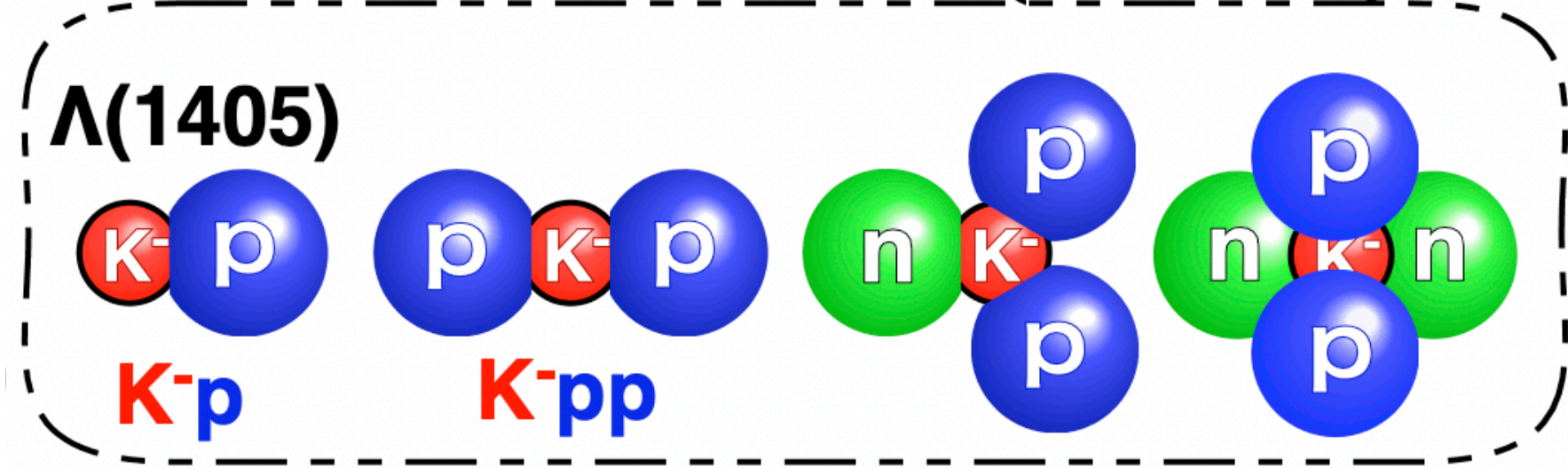

molecule-like hadronic nuclear cluster⁰

"Does it have a unique shape like a chemical molecule?"

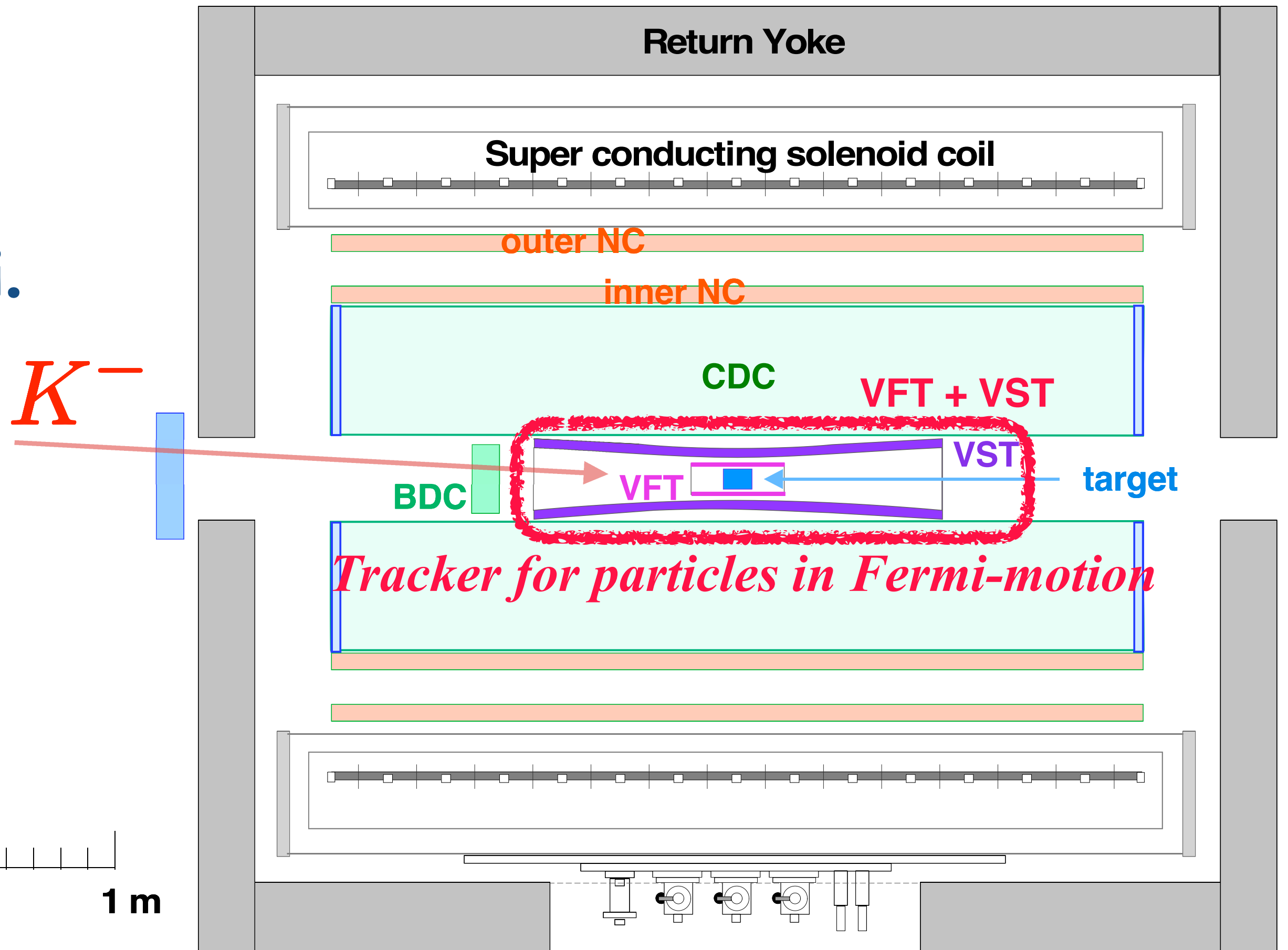

... Construction is in progress, led by *F. Sakuma* 16

New Cylindrical Detector System (CDS)

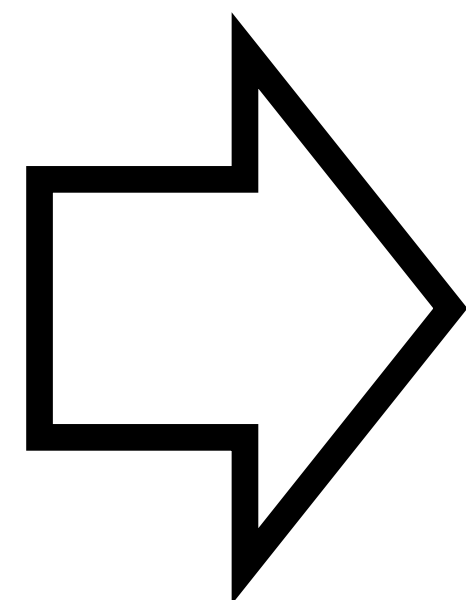
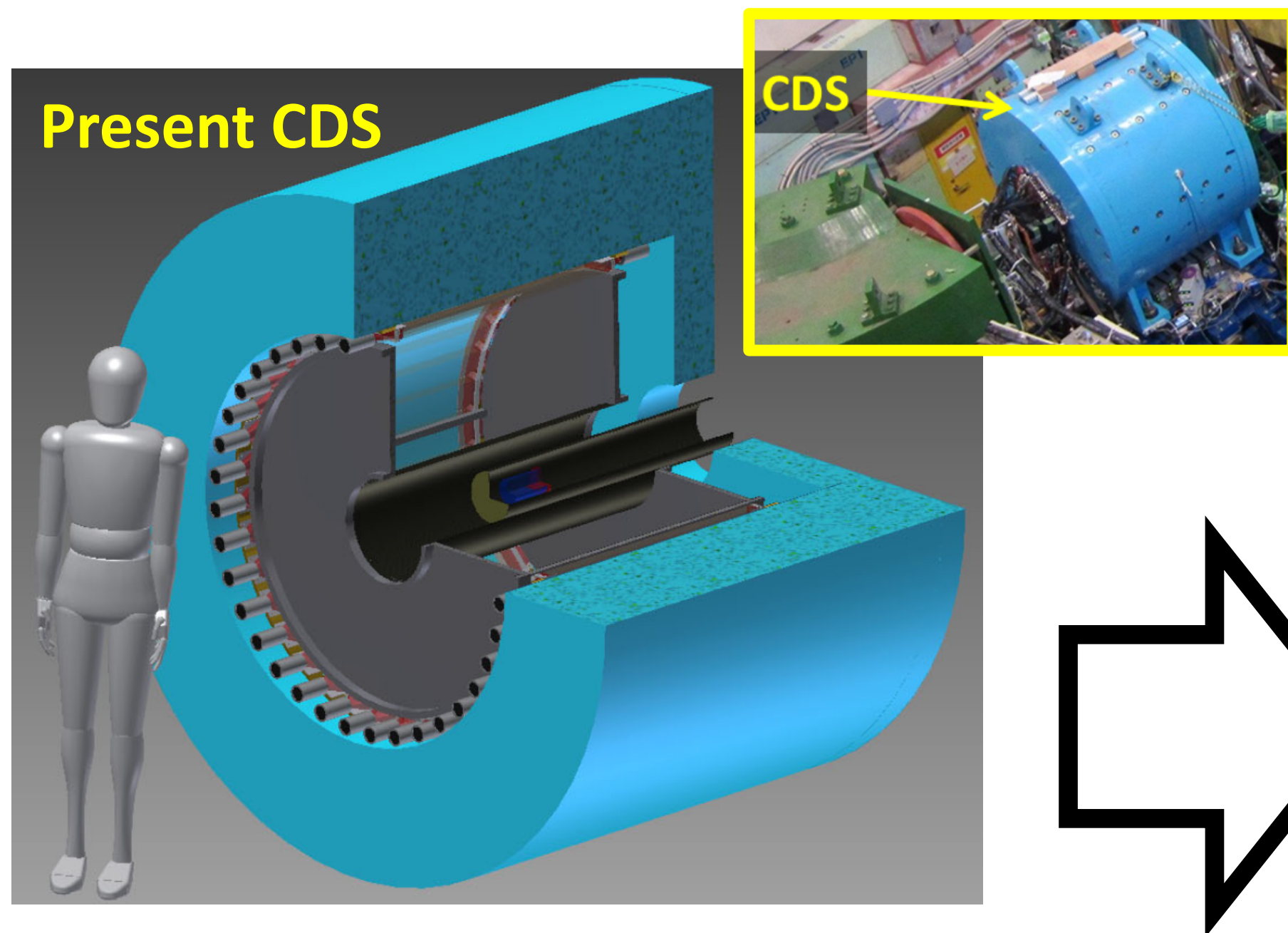

New CDS

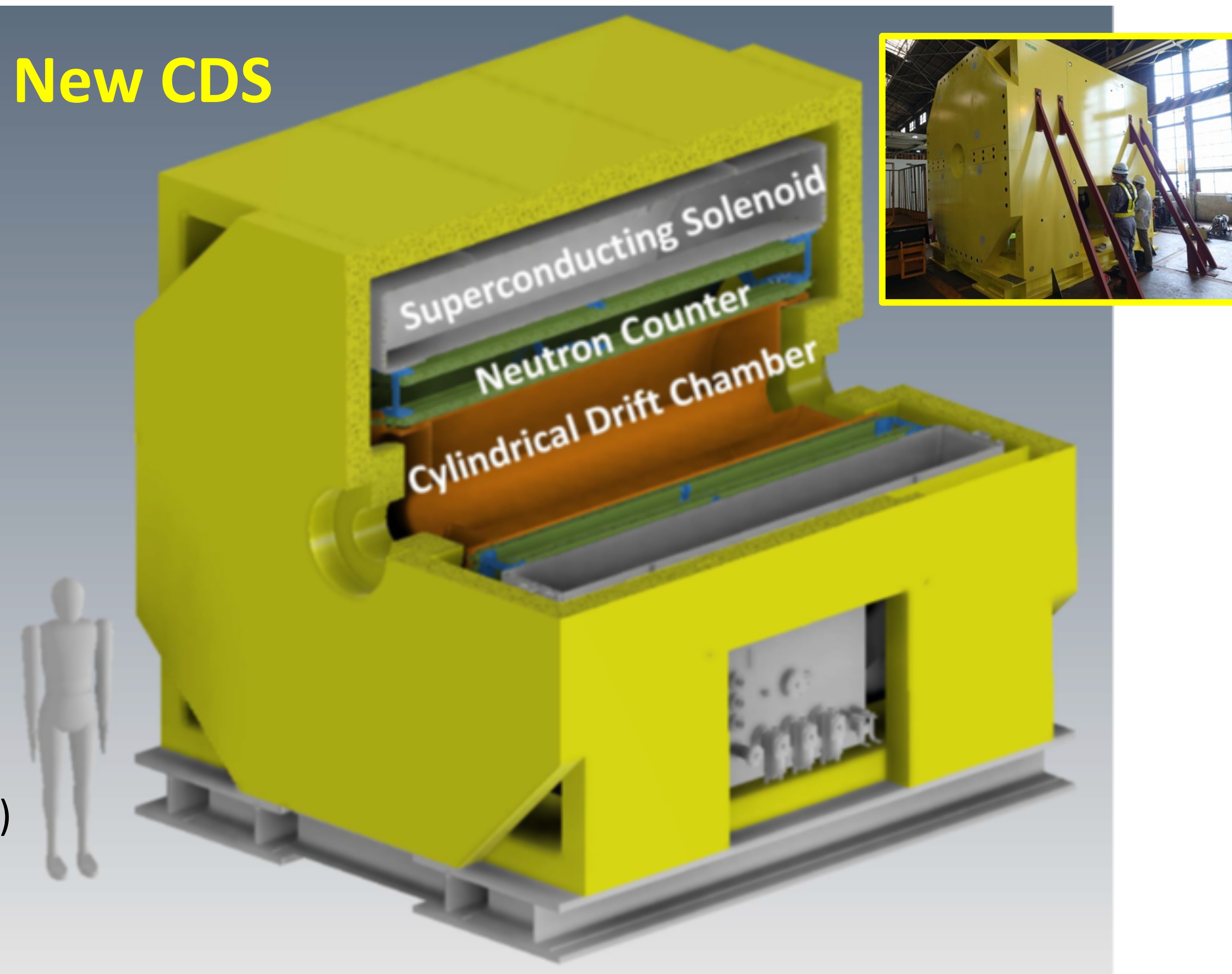

- ✓ **Solid angle: x1.6** (59% → 93%)
- ✓ **Neutron eff.: x7** (3% → 12%x1.6)

With new spectrometer, we will conduct

— a systematic study on light kaonic nuclei —

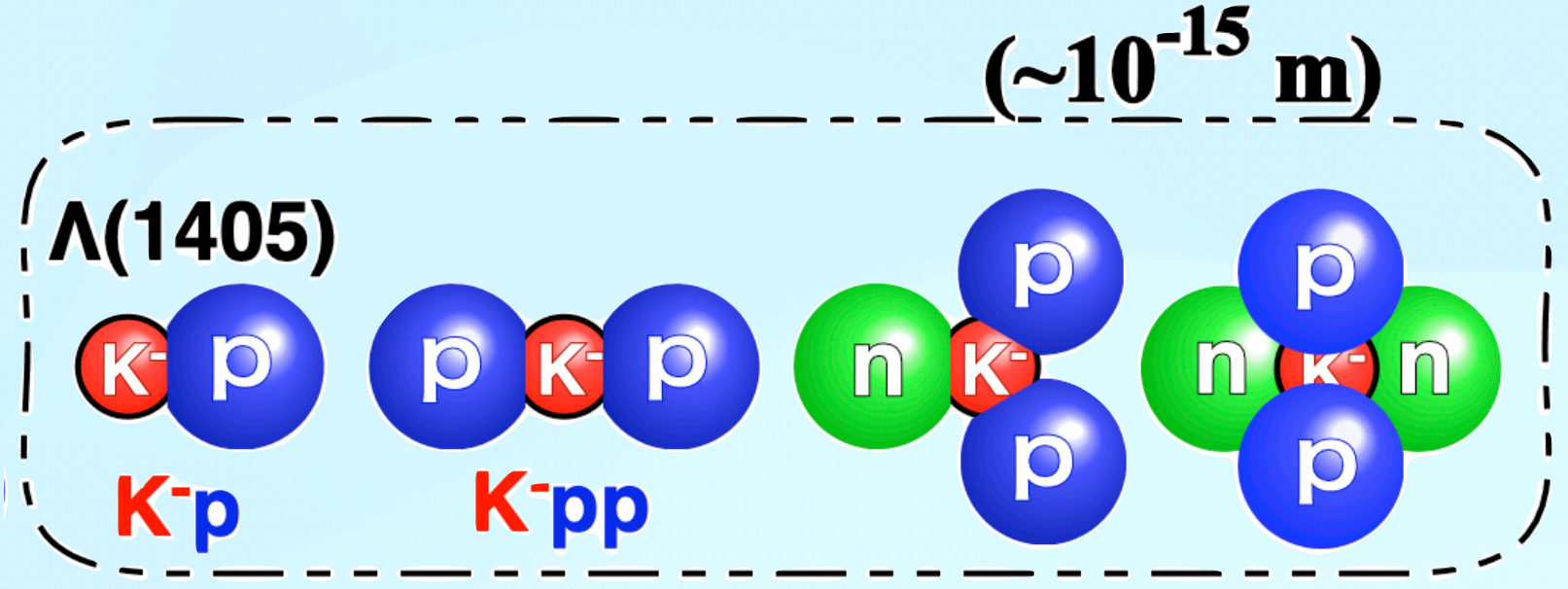

"Does it have a unique shape like a chemical molecule?"

molecule-like hadronic nuclear cluster

How hadron mass is generated?

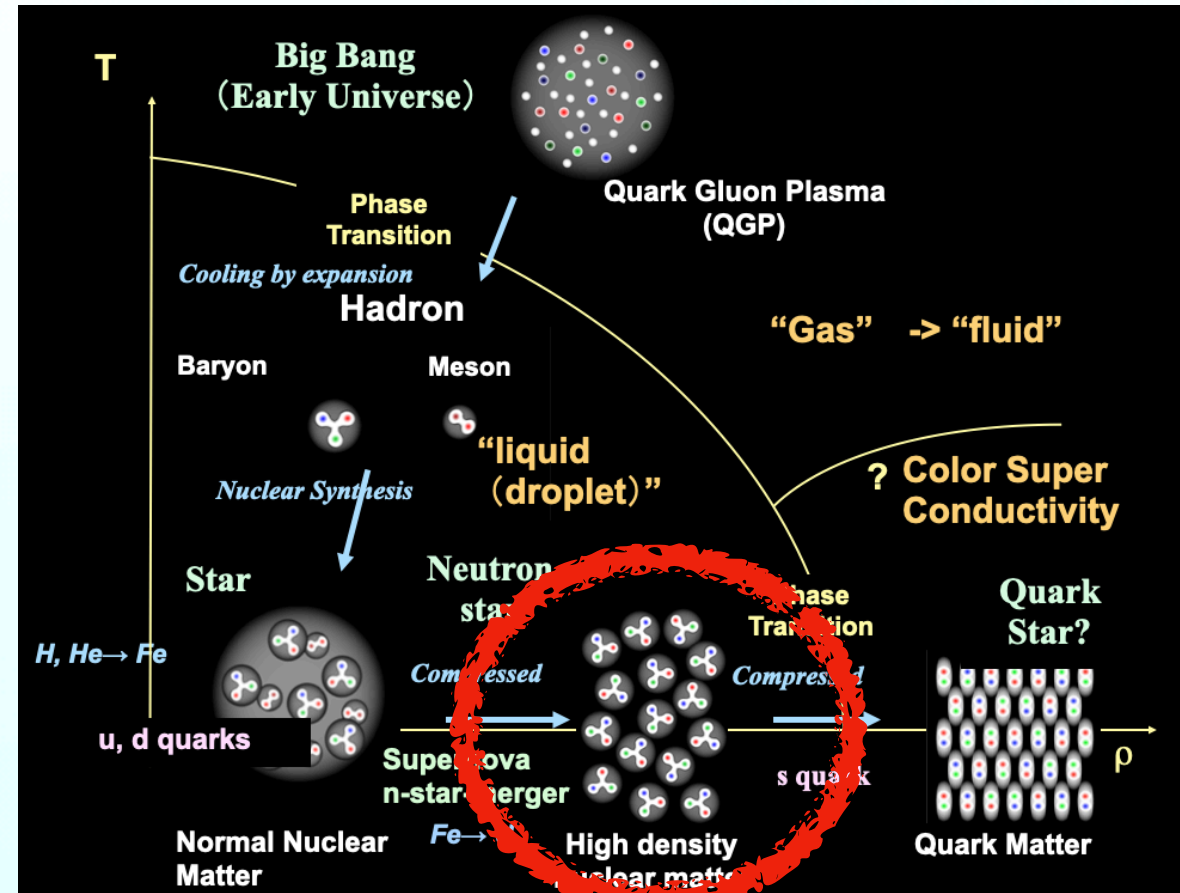

Physics at high density?



By establishing *the $I(J^P)$* , presence of " *$K^- nn$* " — a Charge Mirror State of " *$K^- pp$* " — and *the Detailed Study of Three-Nucleon Kaon Nuclear Bound State as new starting points, we aim to open the door to research on high-density nuclear matter.*



Thank you for your attention!

Mesonic Decay Modes of $\bar{K}NN$

T. Yamaga et.al., Phys. Rev. C 110, 014002 (2024)

- Mesonic decays will give us further information on $\bar{K}NN$

- ✓ internal structure
- ✓ $\bar{K}N$ interaction below the threshold
- ✓ density of the state

S. Ohnishi, et al., Phys. Rev. C 88 (2013) 025204.

$$\Gamma_{YN} \ll \Gamma_{\pi YN}$$

40 times??

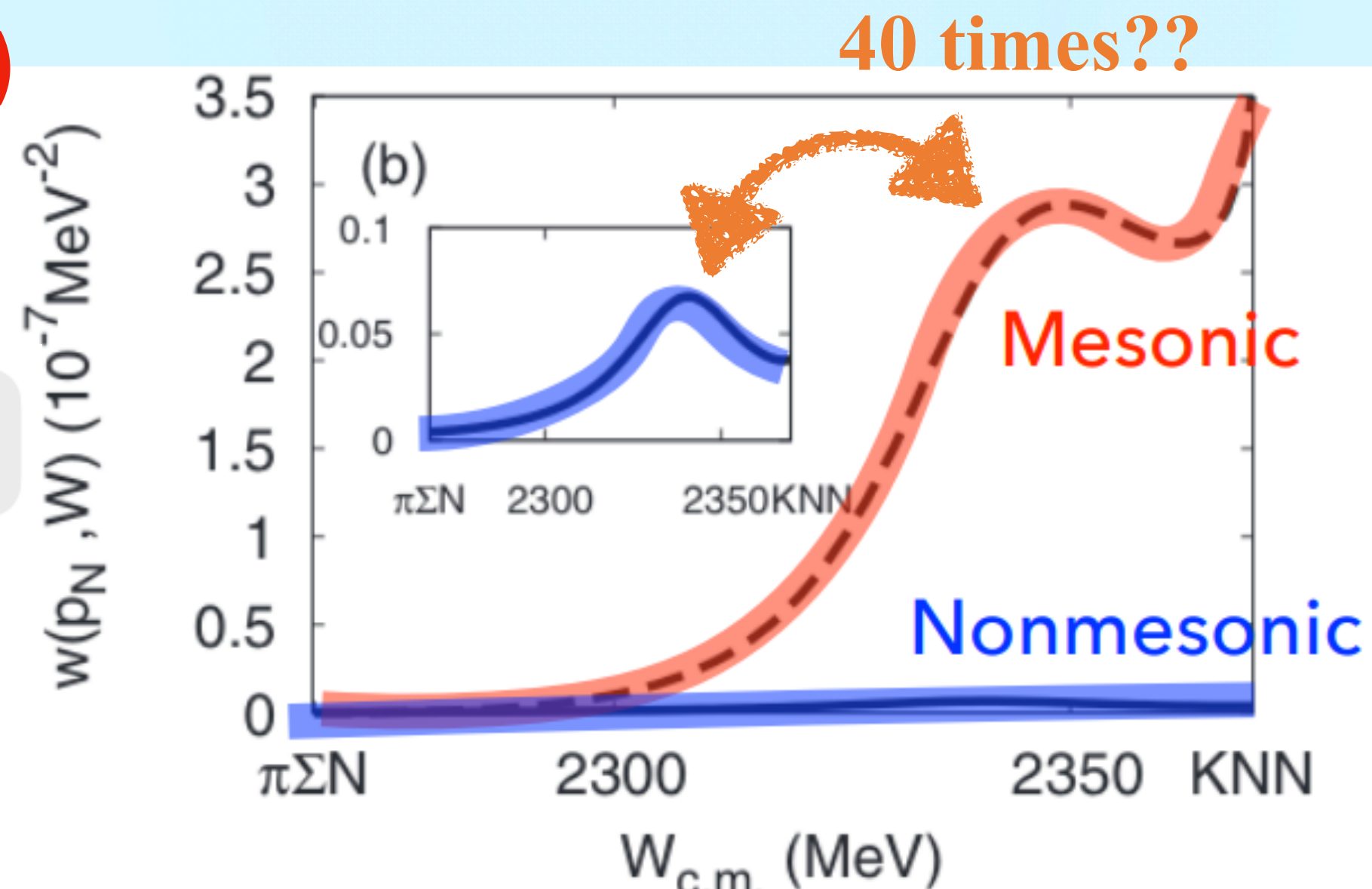

Mesonic

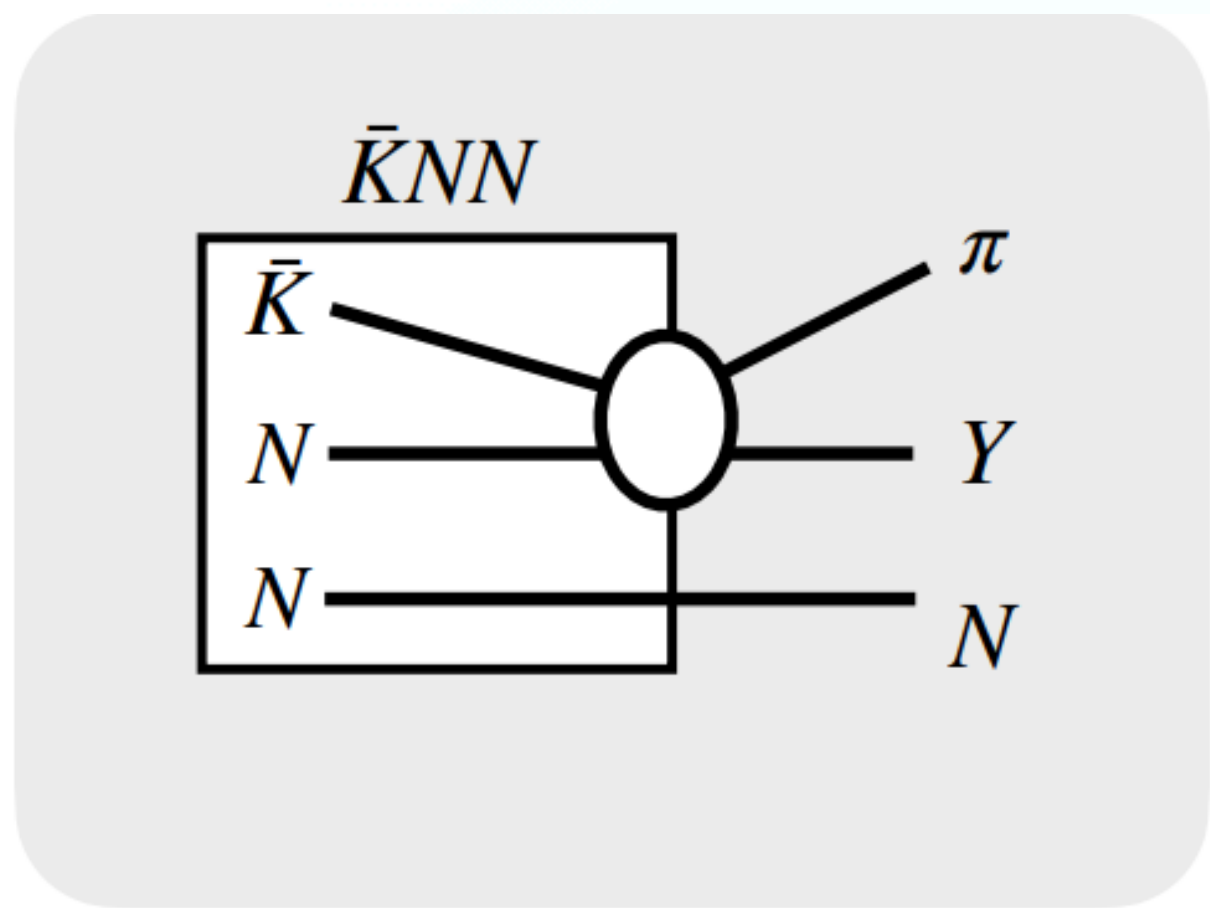

1N absorption

Non-mesonic

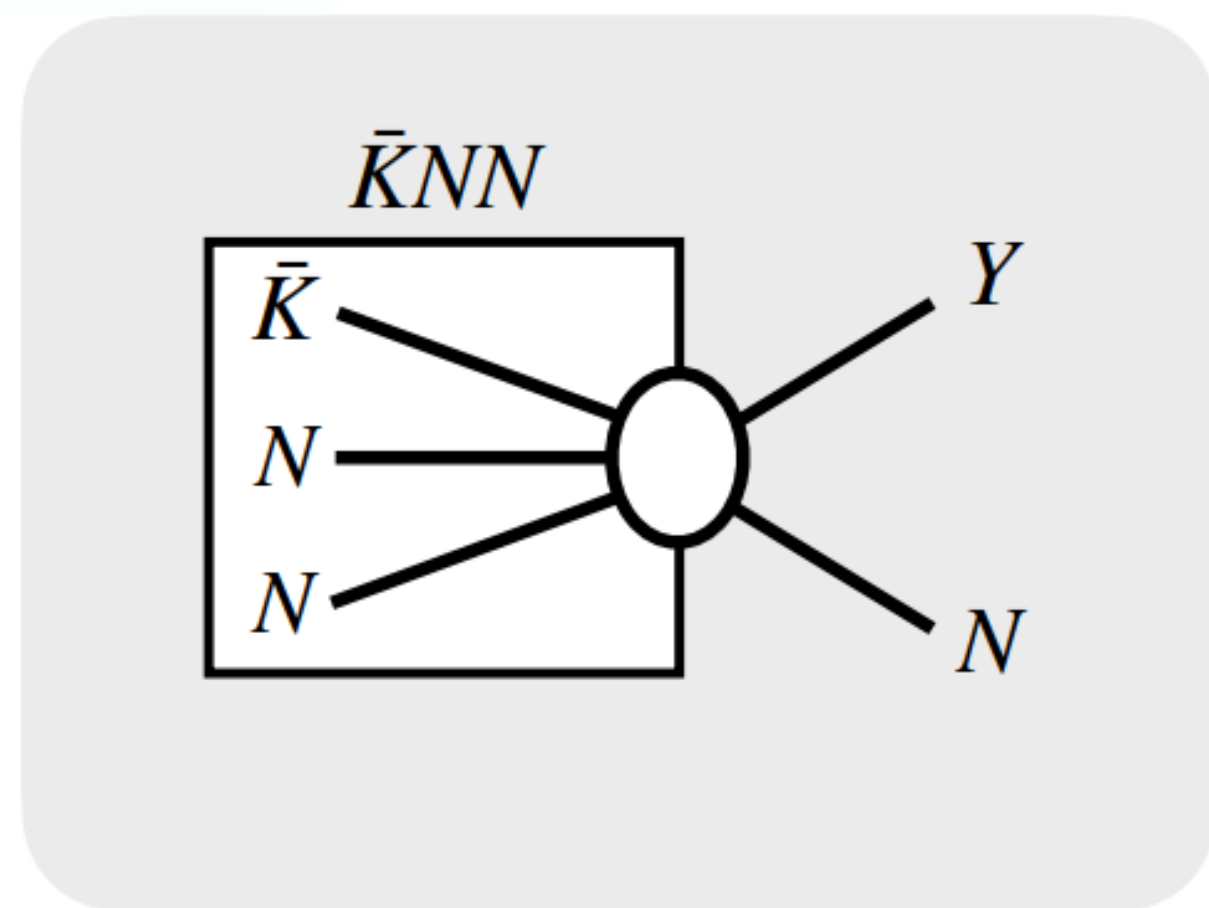

2N absorption

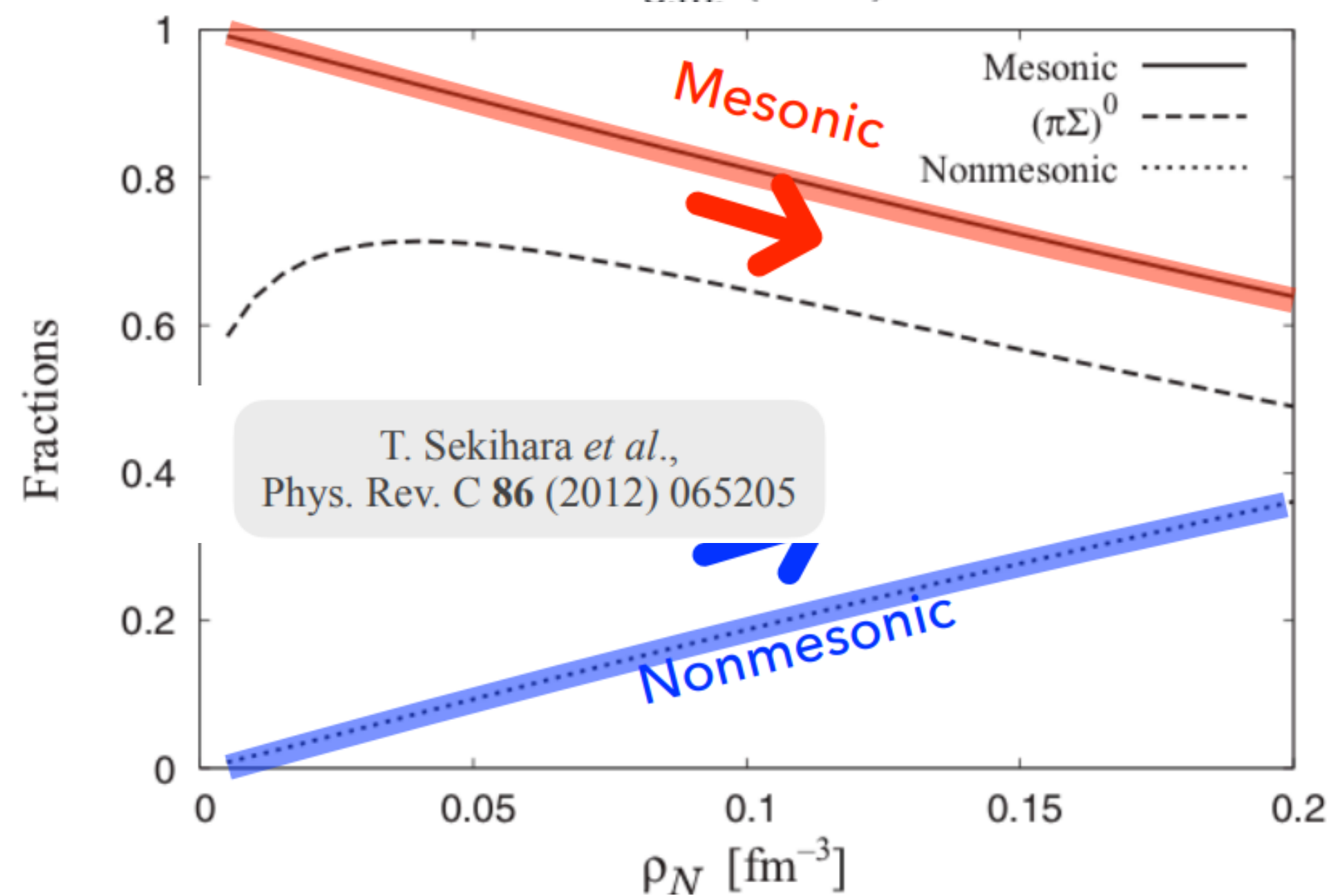

T. Sekihara et al., Phys. Rev. C 86 (2012) 065205

Plane Wave Impulse Approximation
Fit with PWIA $\sigma(M, q) \propto \rho(M, q) \times \frac{(\Gamma_{Kpp}/2)^2}{(M - M_{Kpp})^2 + (\Gamma_{Kpp}/2)^2} \times \exp\left(-\frac{q^2}{Q_{Kpp}^2}\right)$

Phase space
 Energy term (BW type) from time integral
 Momentum term from spatial integral

" $K^- pp$ " \rightarrow Λp

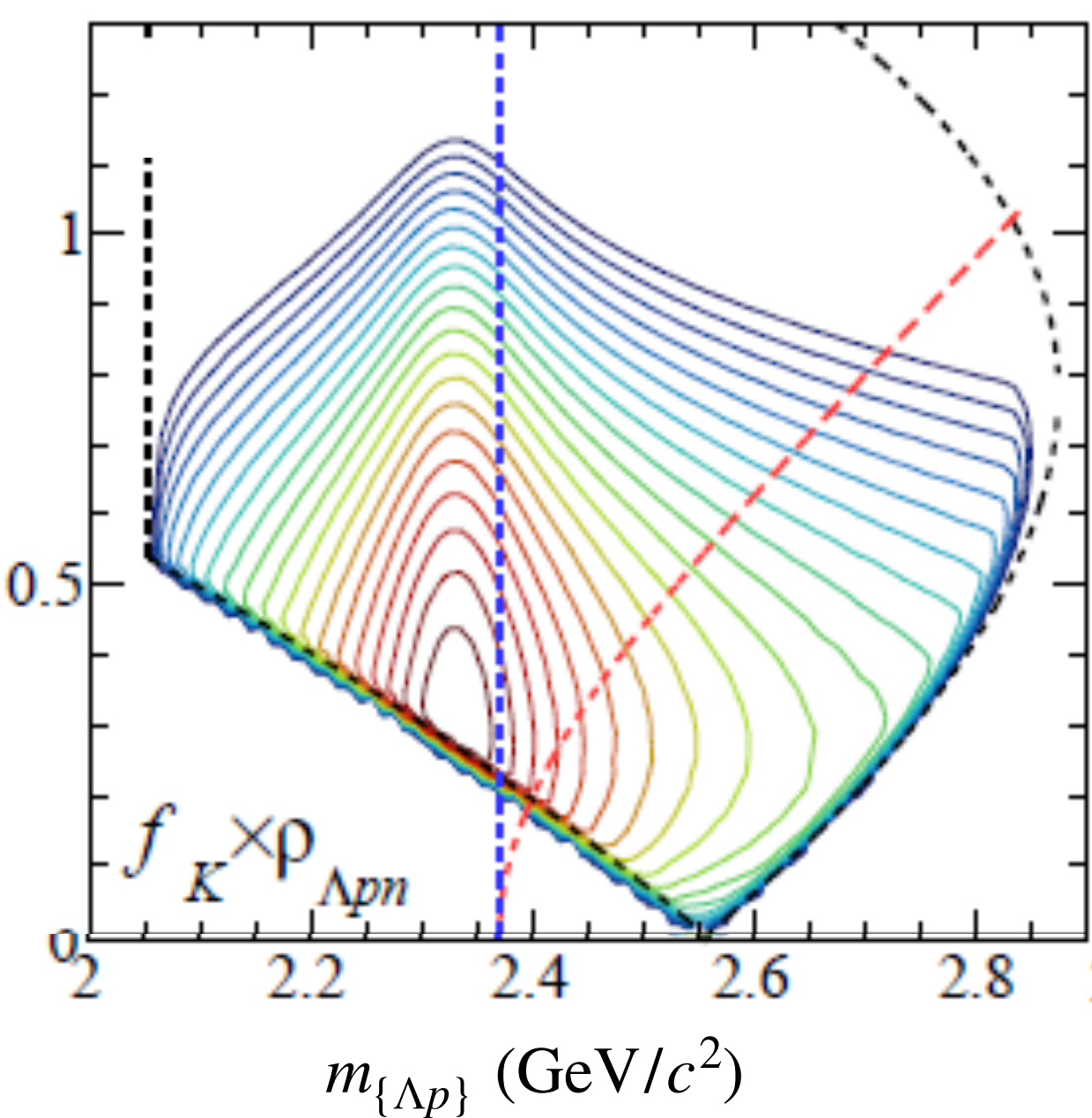

Plane Wave Impulse Approximation
Fit with PWIA

$\sigma(M, q) \propto$

Phase space

$$\rho(M, q)$$

$$\times \frac{(\Gamma_{Kpp}/2)^2}{(M - M_{Kpp})^2 + (\Gamma_{Kpp}/2)^2}$$

Momentum term from spatial integral

$$\times \exp\left(-\frac{q^2}{Q_{Kpp}^2}\right)$$

Energy term (BW type) from time integral

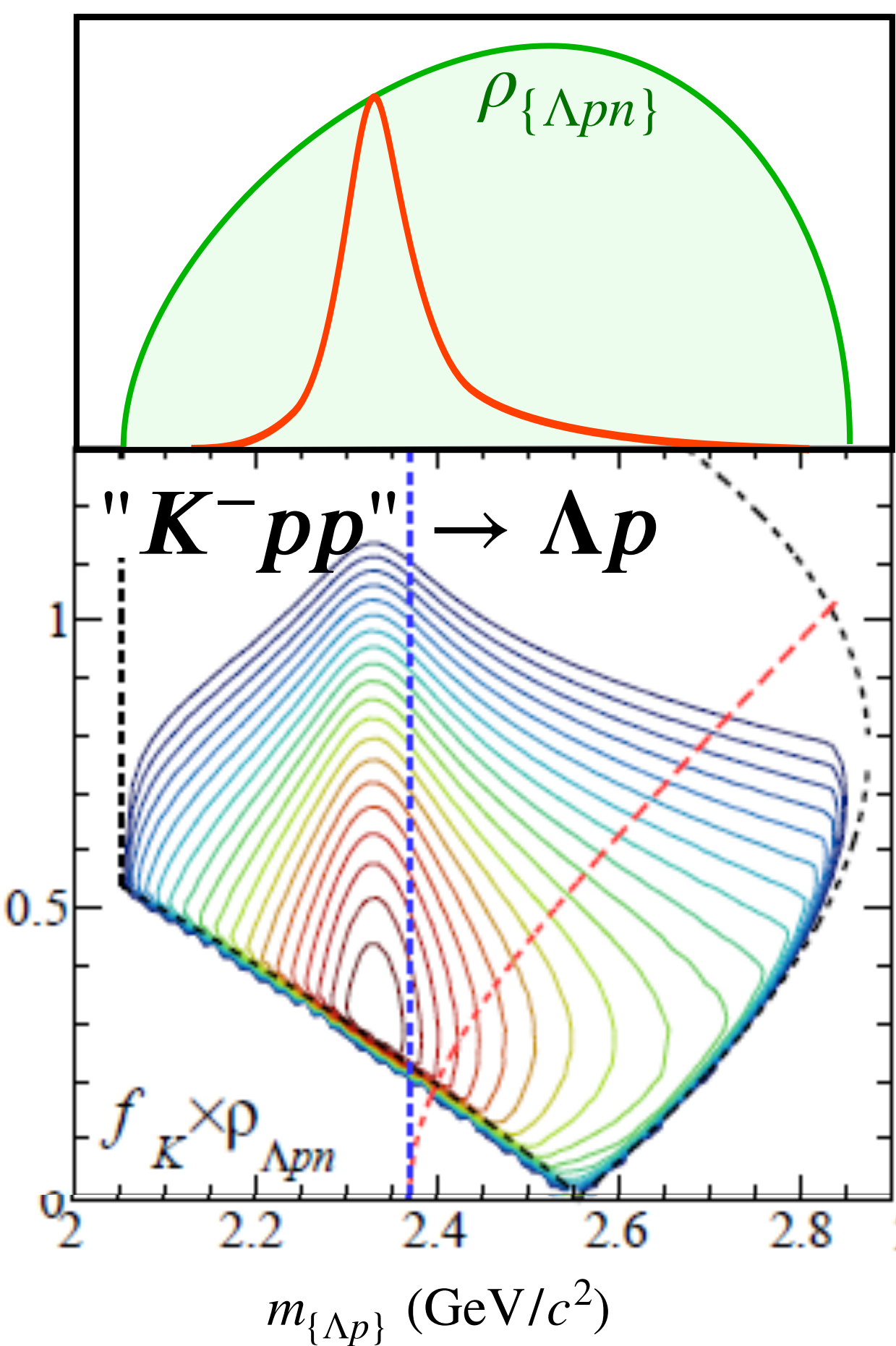

Plane Wave Impulse Approximation

Fit with PWIA $\sigma(M, q) \propto \rho(M, q) \times \frac{(\Gamma_{Kpp}/2)^2}{(M - M_{Kpp})^2 + (\Gamma_{Kpp}/2)^2} \times \exp\left(-\frac{q^2}{Q_{Kpp}^2}\right)$

Phase space

Momentum term from spatial integral

Energy term (BW type) from time integral

Mesonic decay suppression / spectral modification happens, due to the *Phase Space Difference!*

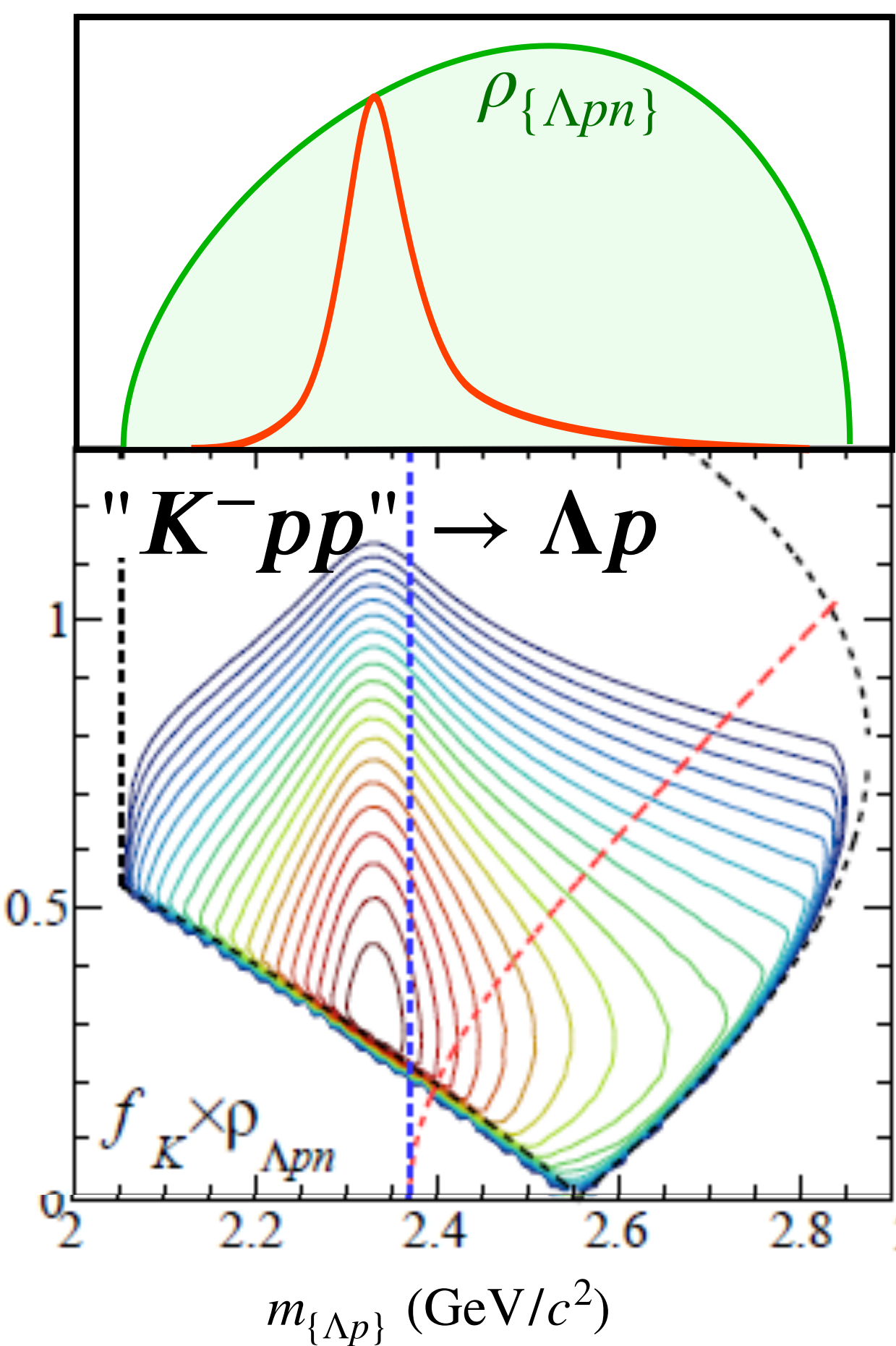

Mesonic decay suppression / spectral modification happens, due to the *Phase Space Difference!*

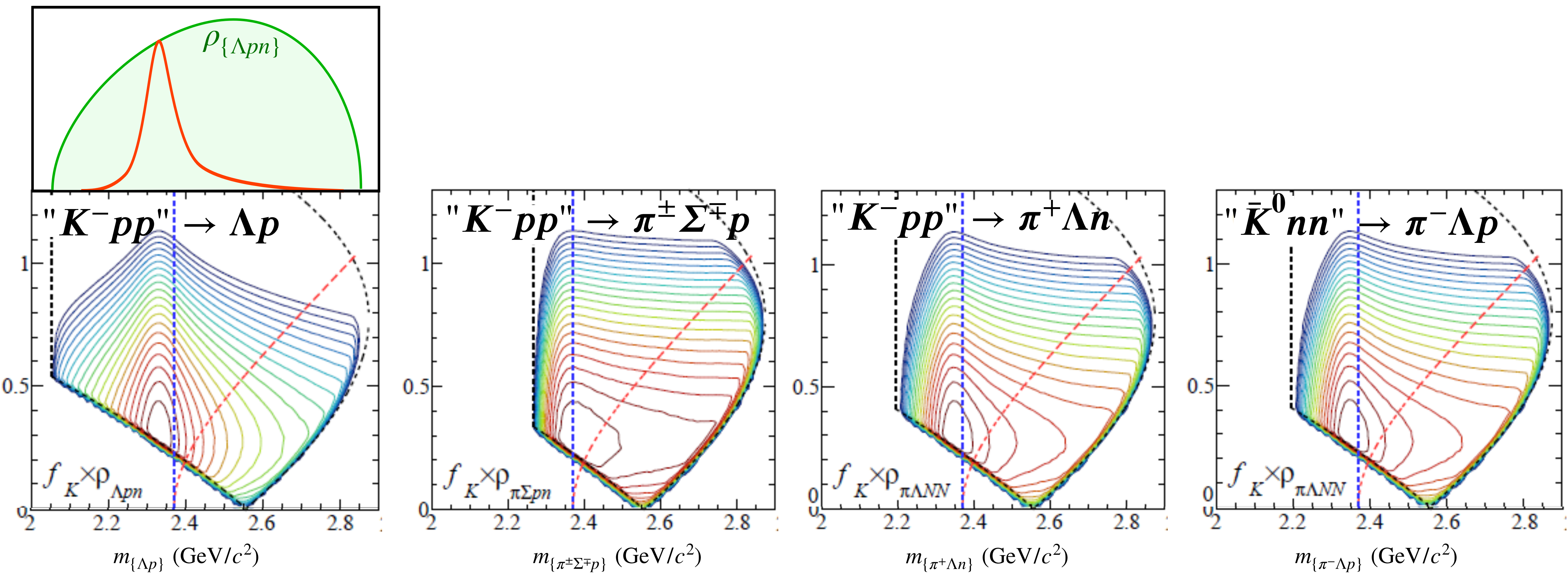

Mesonic decay suppression / spectral modification happens, due to the *Phase Space Difference!*

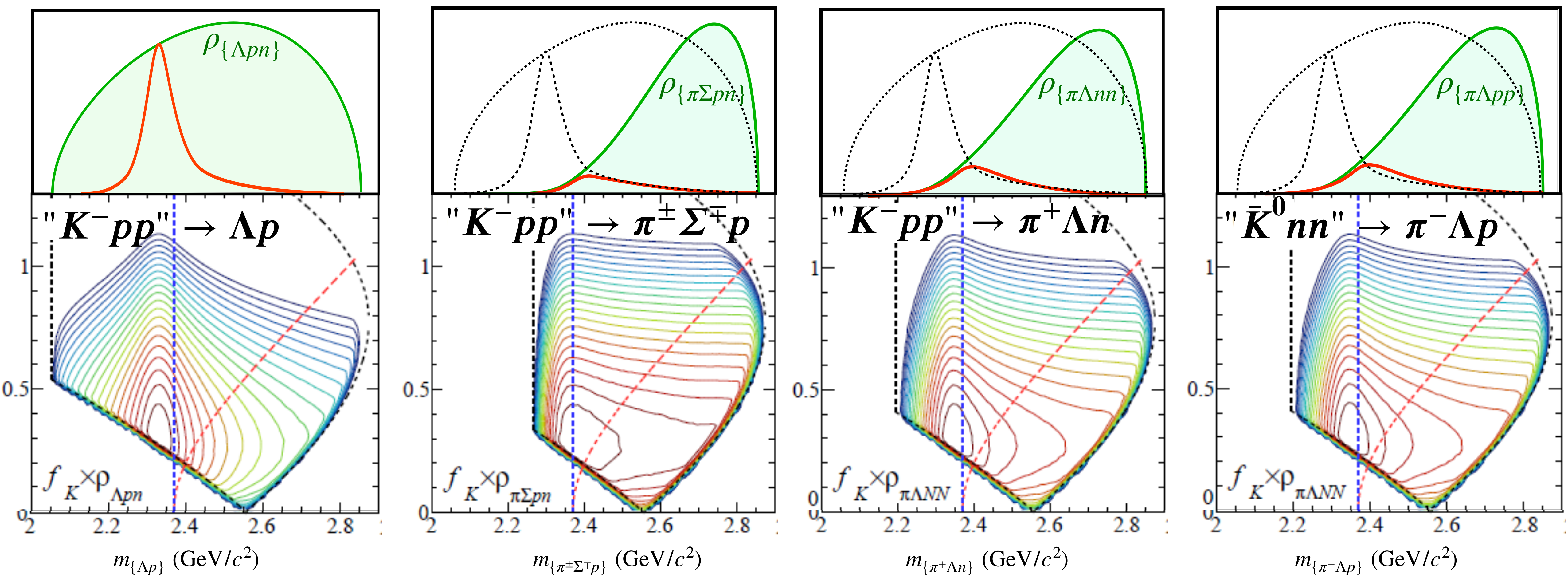

Mesonic decay suppression / spectral modification happens, due to the *Phase Space Difference!*

1) mass threshold $m_{\{\pi\Lambda p\}} \in [m_{\Lambda} + m_p, E_{\{K^3\text{He}\}}^* - m_n] \rightarrow [m_{\pi} + m_Y + m_N, E_{\{K^3\text{He}\}}^* - m_N]$

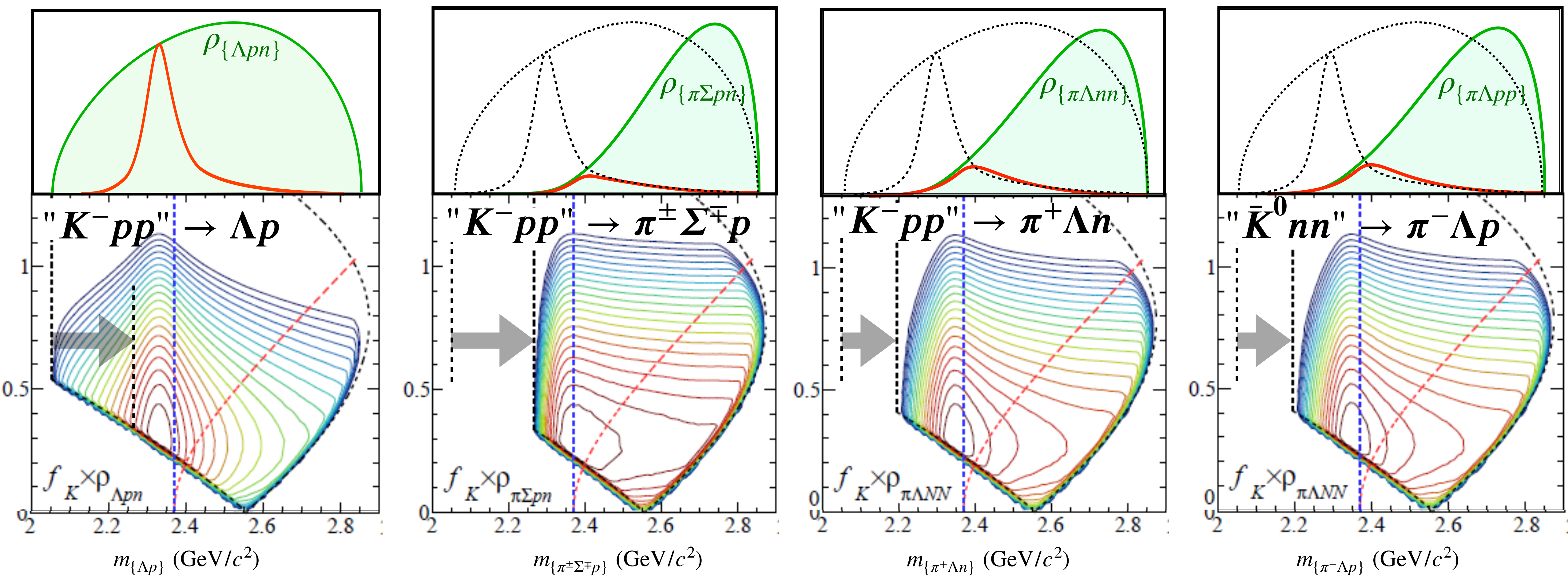

Mesonic decay suppression / spectral modification happens, due to the *Phase Space Difference!*

1) mass threshold $m_{\{\pi\Lambda p\}} \in [m_{\Lambda} + m_p, E_{\{K^3\text{He}\}}^* - m_n] \rightarrow [m_{\pi} + m_Y + m_N, E_{\{K^3\text{He}\}}^* - m_N]$

2) Near the thresholds, the four-body phase space is significantly suppressed compared to that of the three-body phase space.

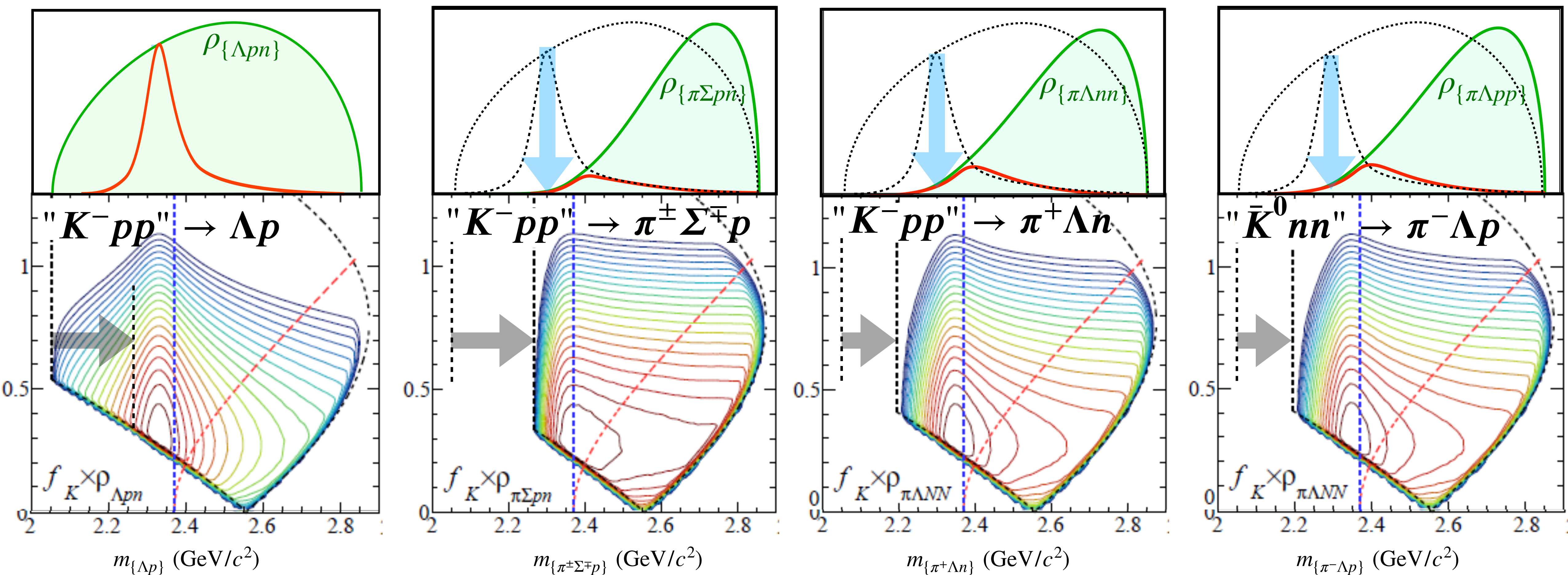

Mesonic decay suppression / spectral modification happens, due to the *Phase Space Difference!*

1) mass threshold $m_{\{\pi\Lambda p\}} \in [m_{\Lambda} + m_p, E_{\{K^3\text{He}\}}^* - m_n] \rightarrow [m_{\pi} + m_Y + m_N, E_{\{K^3\text{He}\}}^* - m_N]$

2) Near the thresholds, the four-body phase space is significantly suppressed compared to that of the three-body phase space.

Thus, the peak structure is difficult to be detected in the $K^- + {}^3\text{He} \rightarrow \{\pi Y N\} + N'$ reaction dynamics.

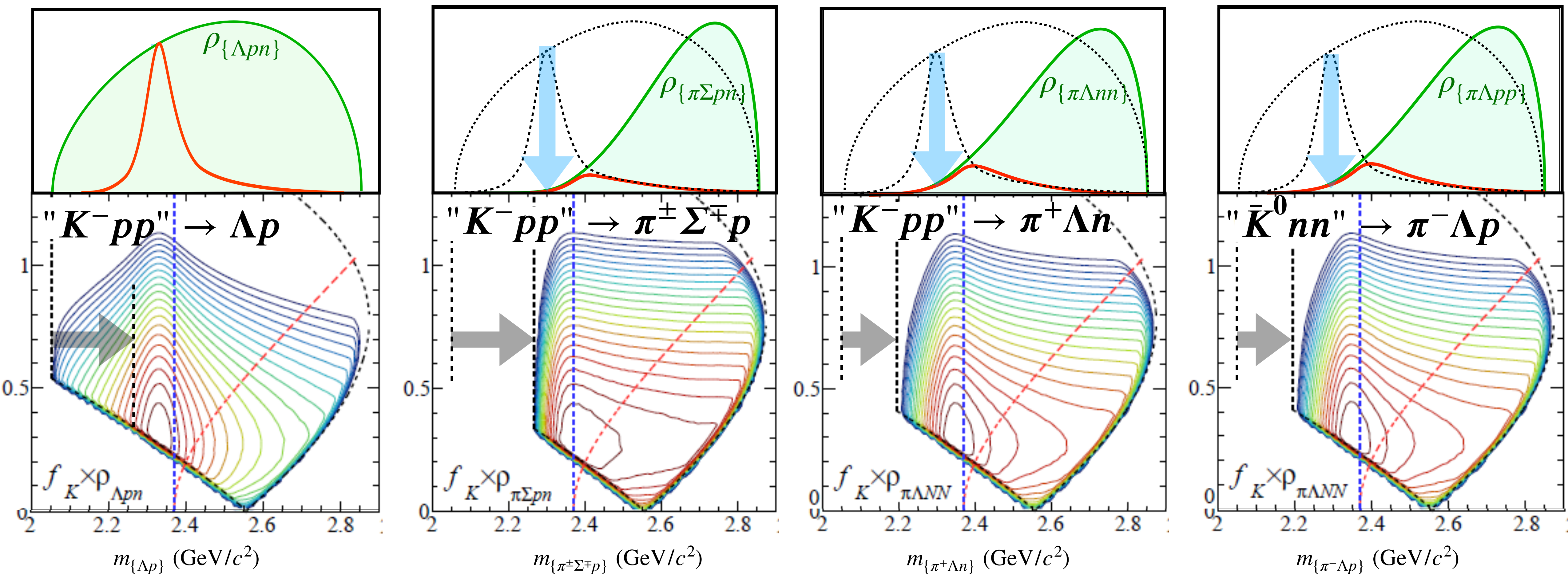

Mesonic decay suppression / spectral modification happens, due to the *Phase Space Difference!*

1) mass threshold $m_{\{\pi\Lambda p\}} \in [m_{\Lambda} + m_p, E_{\{K^3\text{He}\}}^* - m_n] \rightarrow [m_{\pi} + m_Y + m_N, E_{\{K^3\text{He}\}}^* - m_N]$

2) Near the thresholds, the four-body phase space is significantly suppressed compared to that of the three-body phase space.

Thus, the peak structure is difficult to be detected in the $K^- + {}^3\text{He} \rightarrow \{\pi Y N\} + N'$ reaction dynamics.

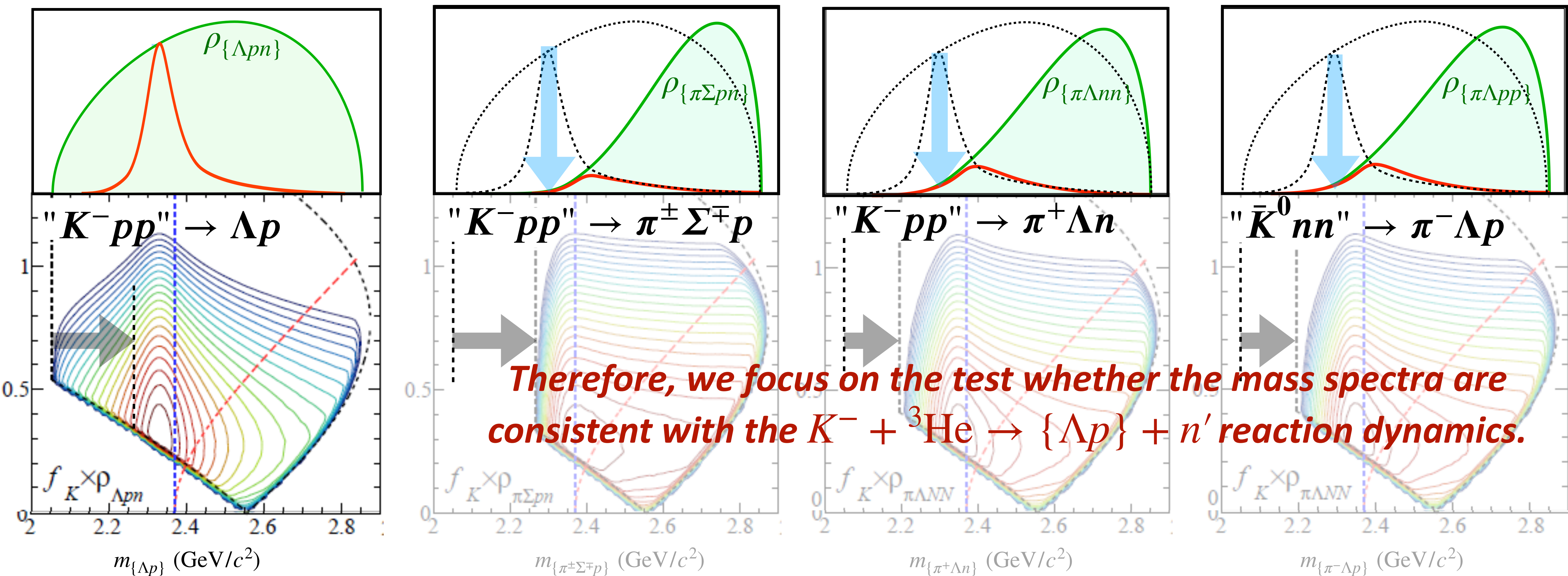

Mesonic Decay Analysis (with the E15 Data)

- with neutron detection using a thin scintillation counter array (CDH)
 - small efficiency (3~9%)
 - BG from the inner wall of the magnet

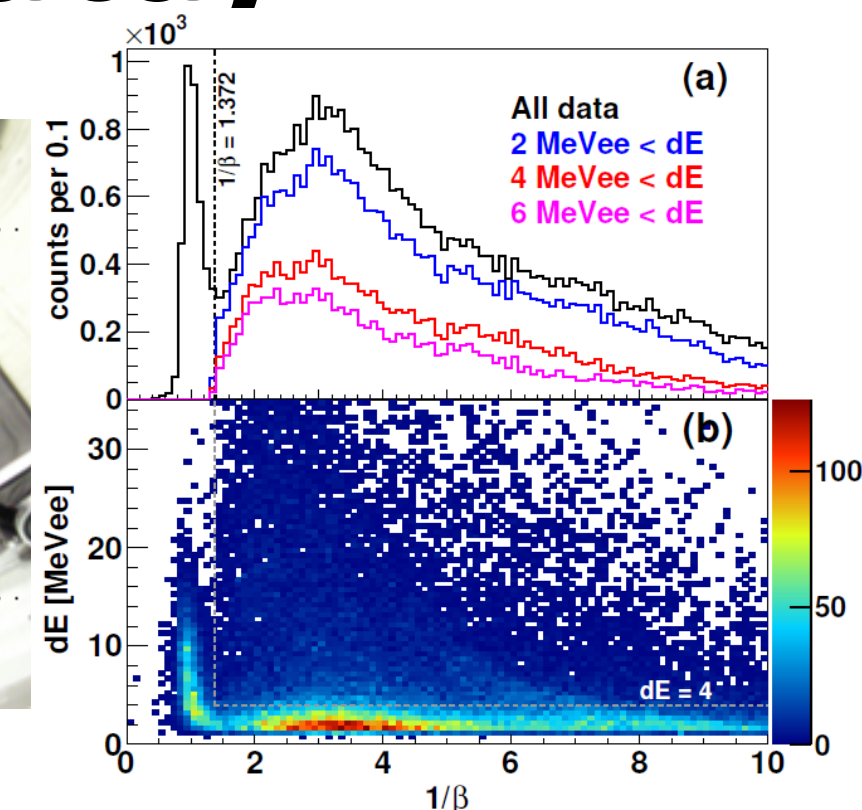
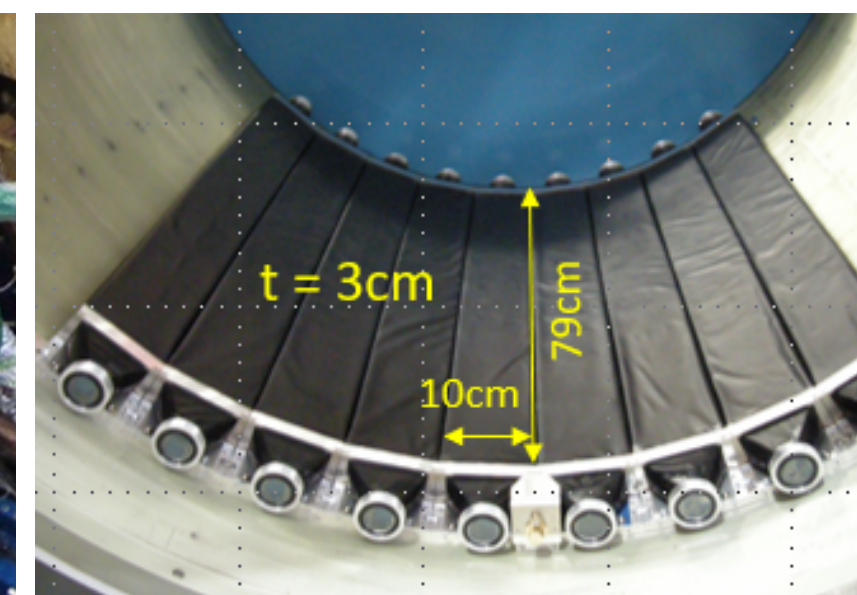
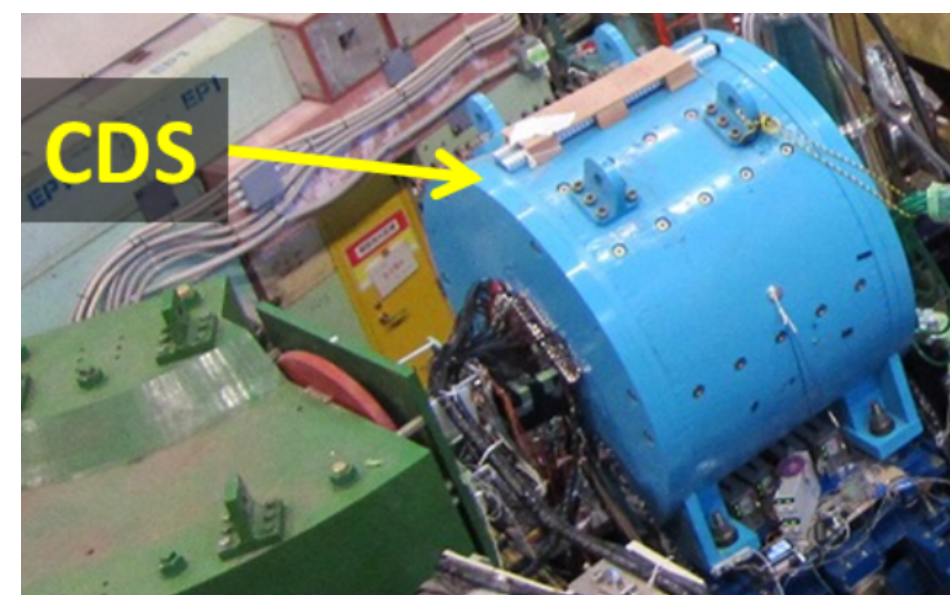

" $K^- pp$ " \rightarrow Λp

$m_{\bar{K}} + 2m_N$

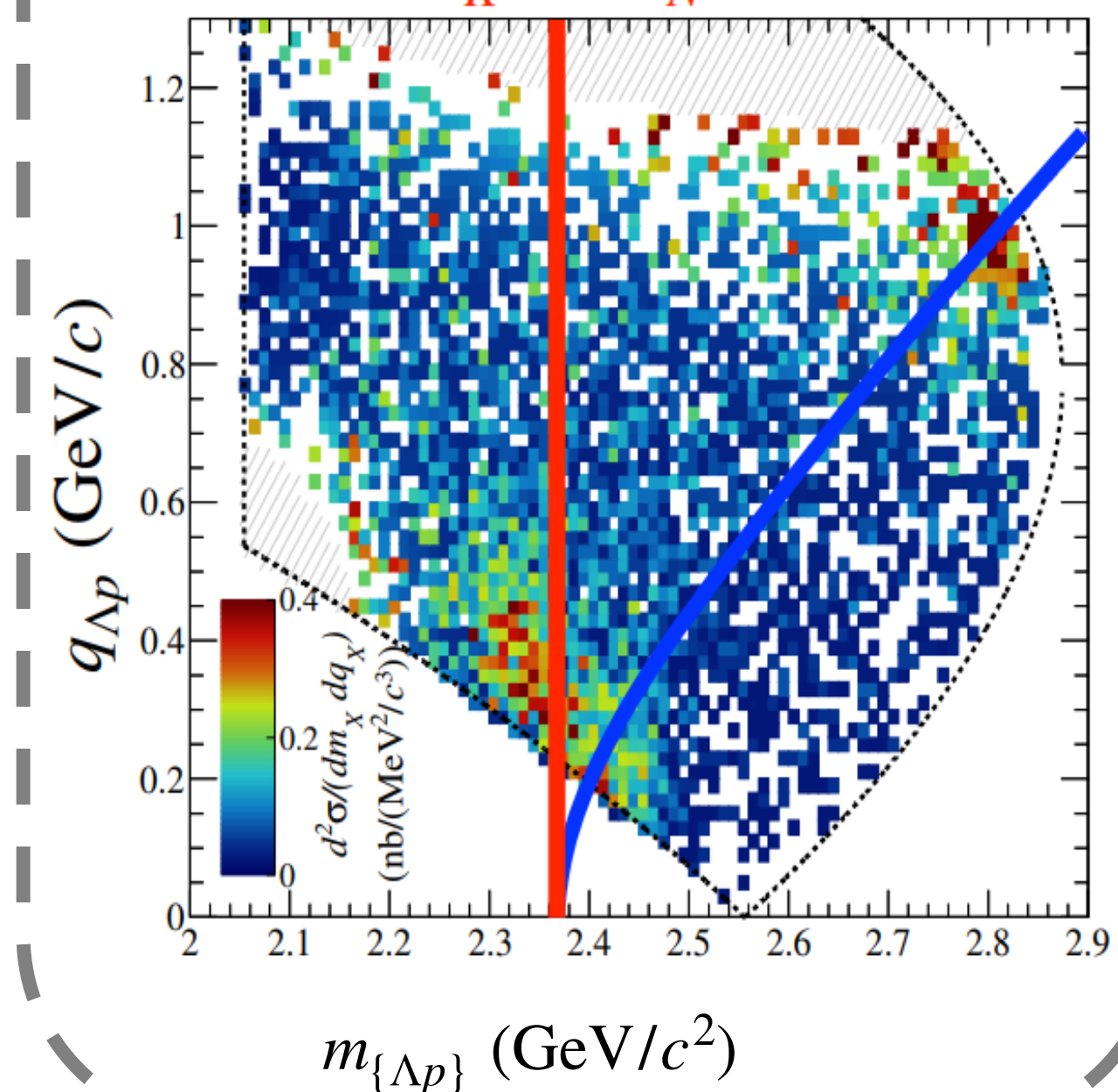

" $K^- pp$ " \rightarrow $\pi^\pm \Sigma^\mp p$

$m_{\bar{K}} + 2m_N$

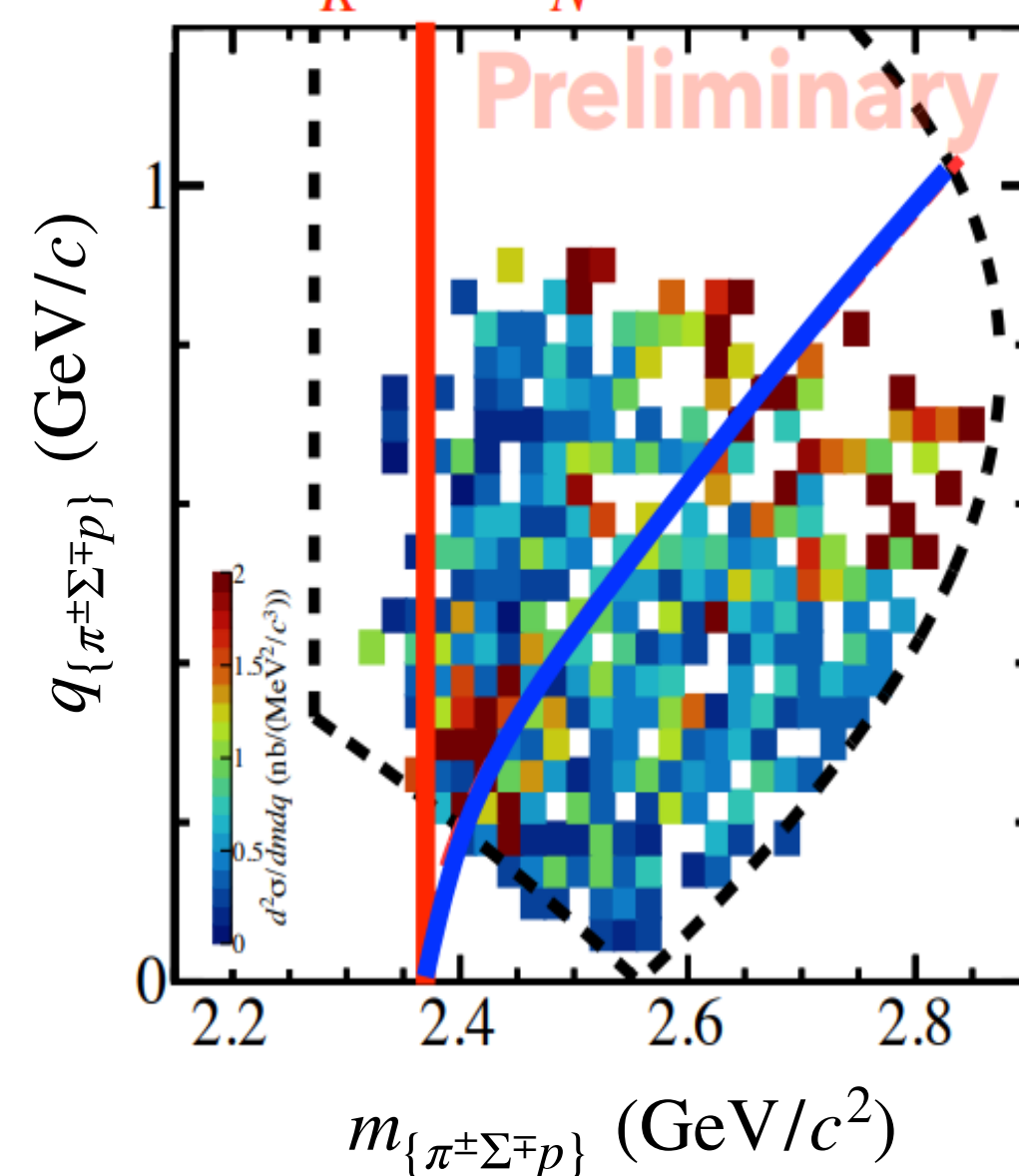

" $K^- pp$ " \rightarrow $\pi^+ \Lambda n$

$m_{\bar{K}} + 2m_N$

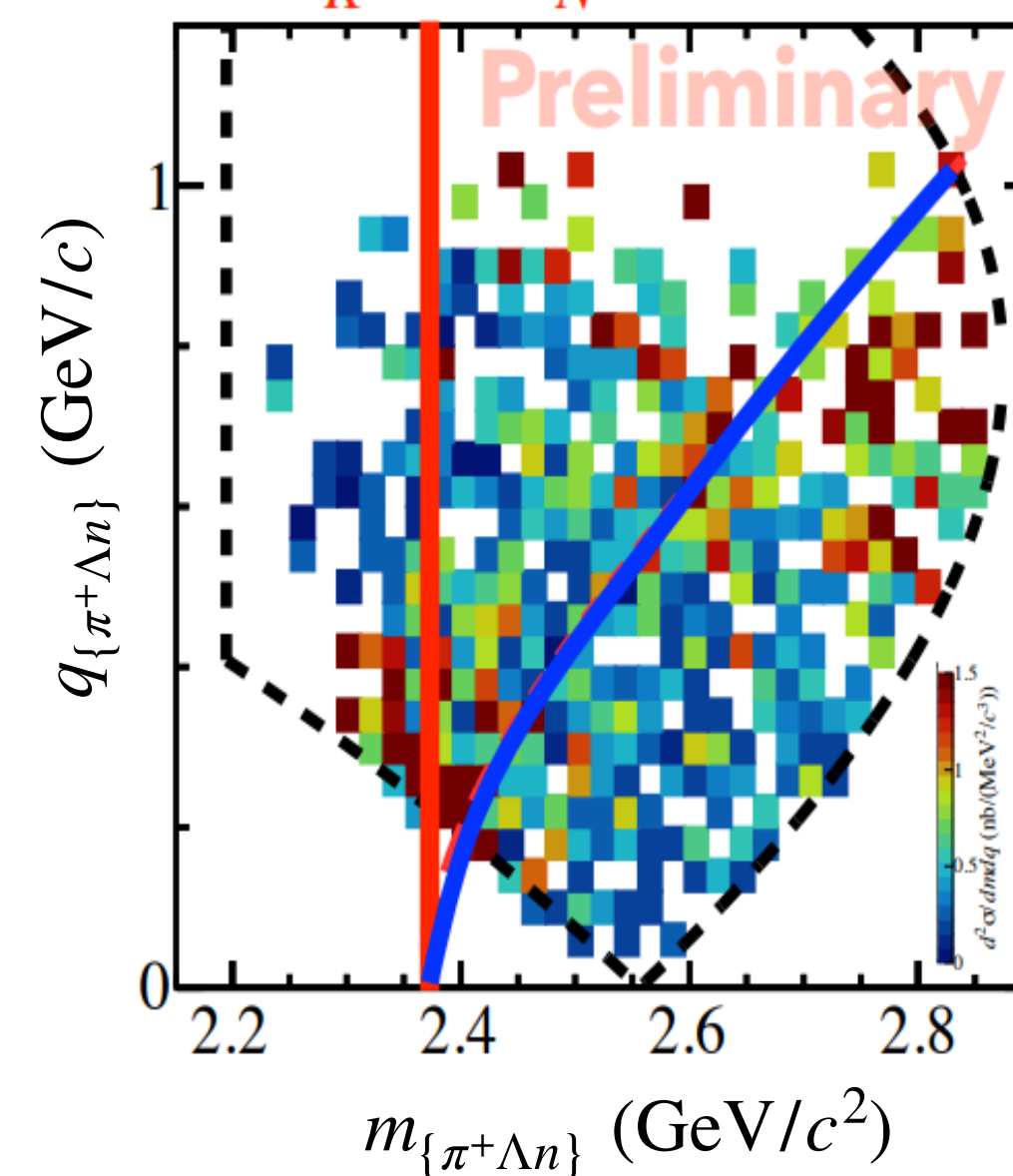

" $\bar{K}^0 nn$ " \rightarrow $\pi^- \Lambda p$

2NA w/ p_{Fermi}

$m_{\bar{K}} + 2m_N$

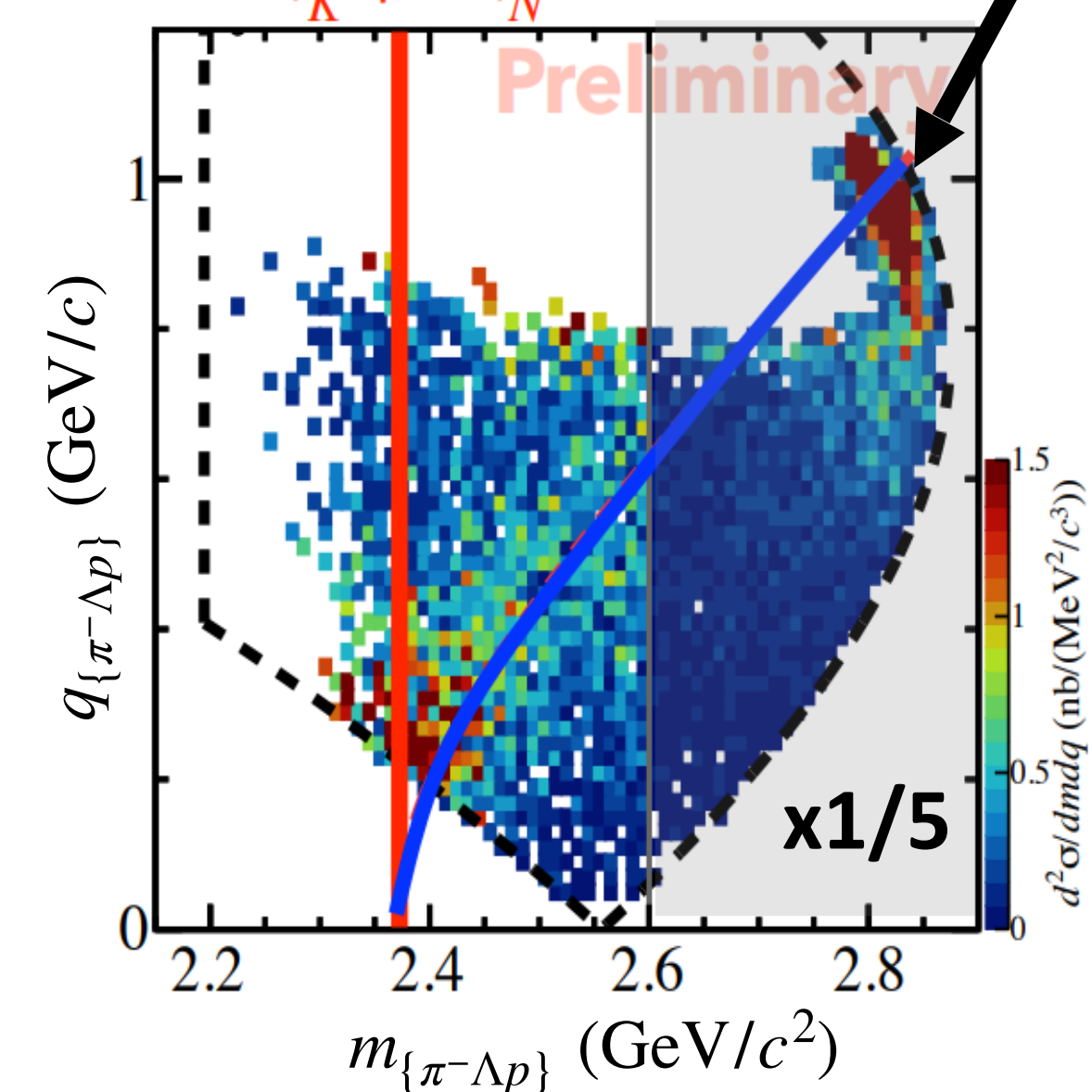

Mesonic Decay Analysis (with the E15 Data)

Plane Wave Impulse Approximation
Fit with PWIA $\sigma(M, q) \propto \rho(M, q) \times \frac{(\Gamma_{Kpp}/2)^2}{(M - M_{Kpp})^2 + (\Gamma_{Kpp}/2)^2} \times \exp\left(-\frac{q^2}{Q_{Kpp}^2}\right)$

Phase space
 Energy term (BW type) from time integral
 Momentum term from spatial integral

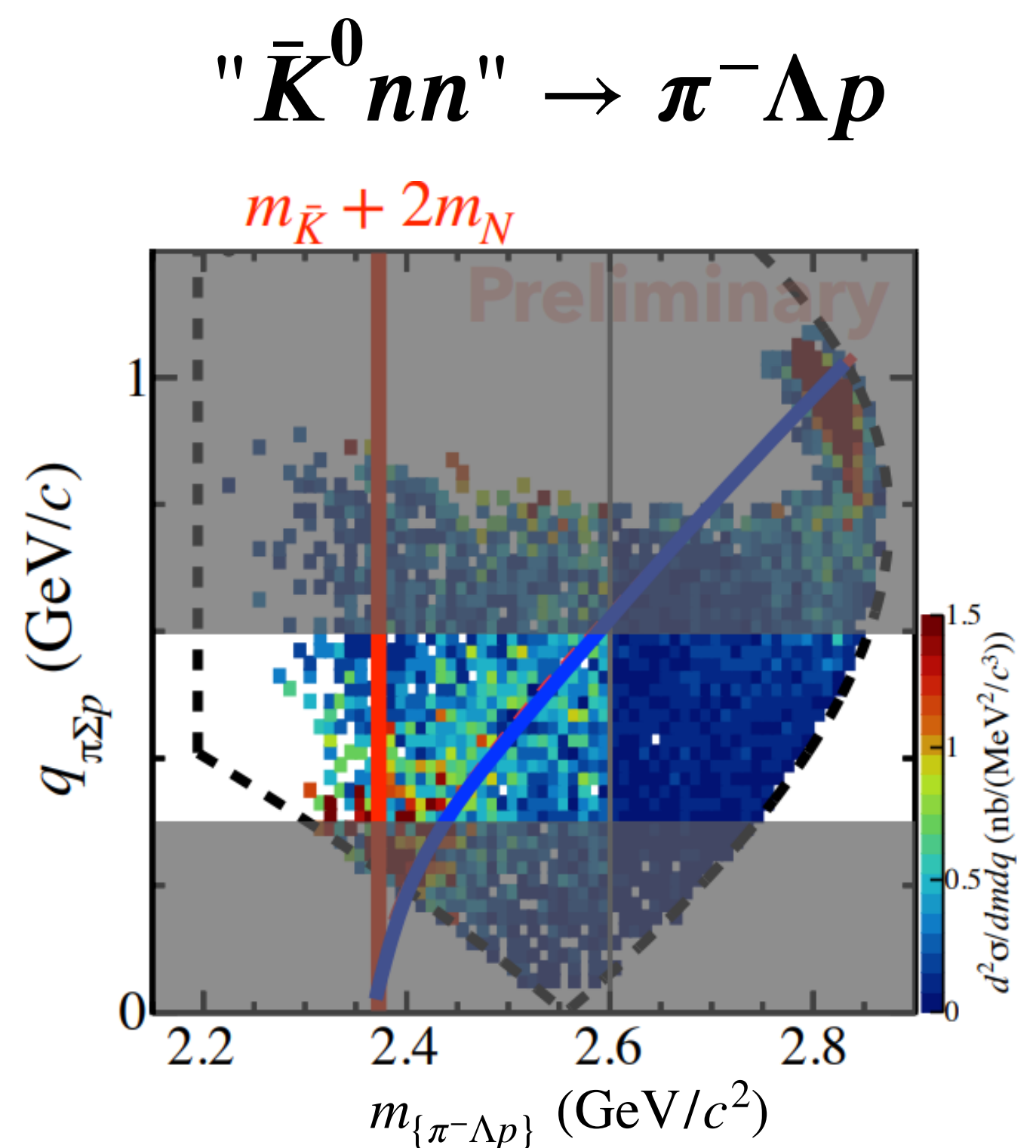
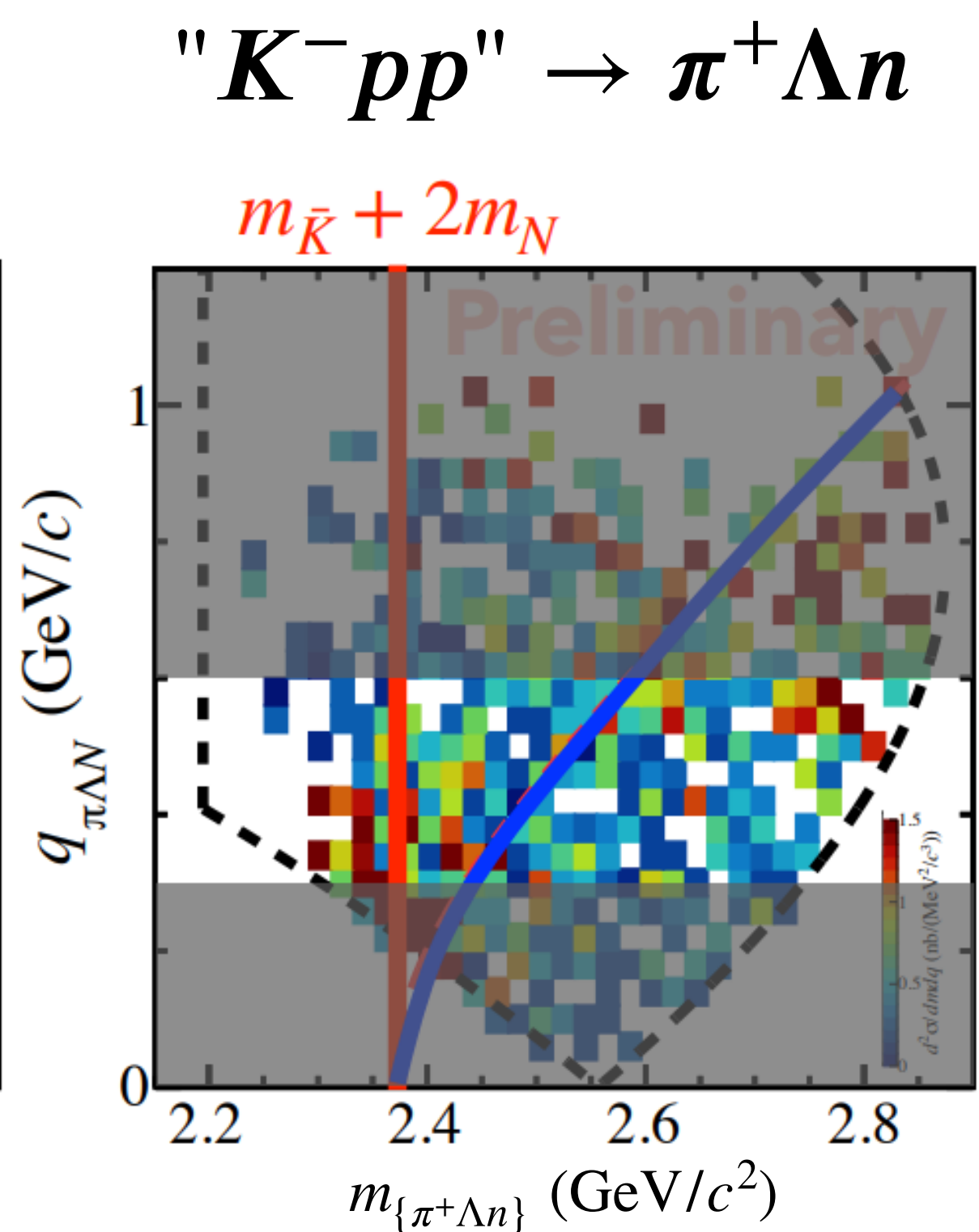
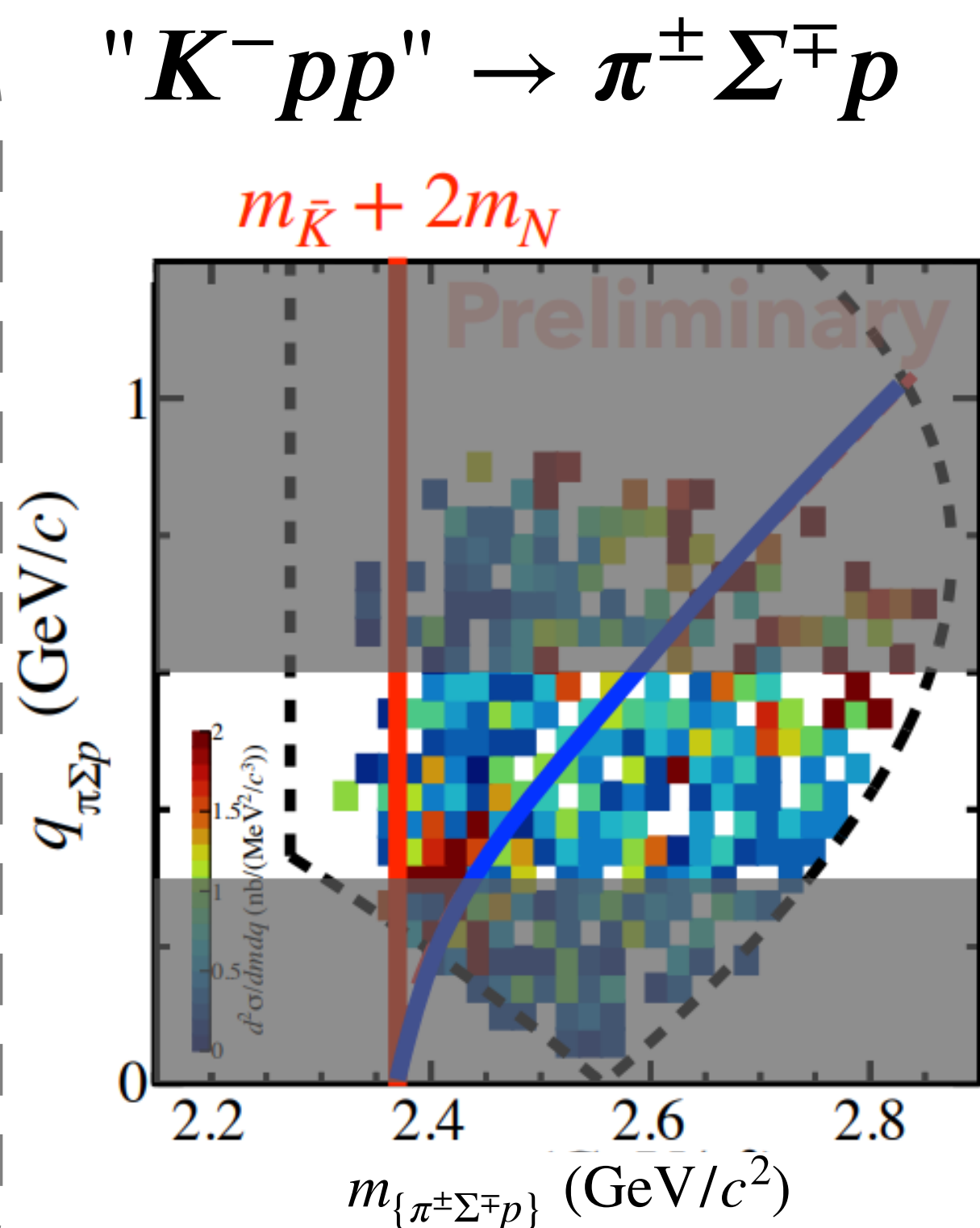
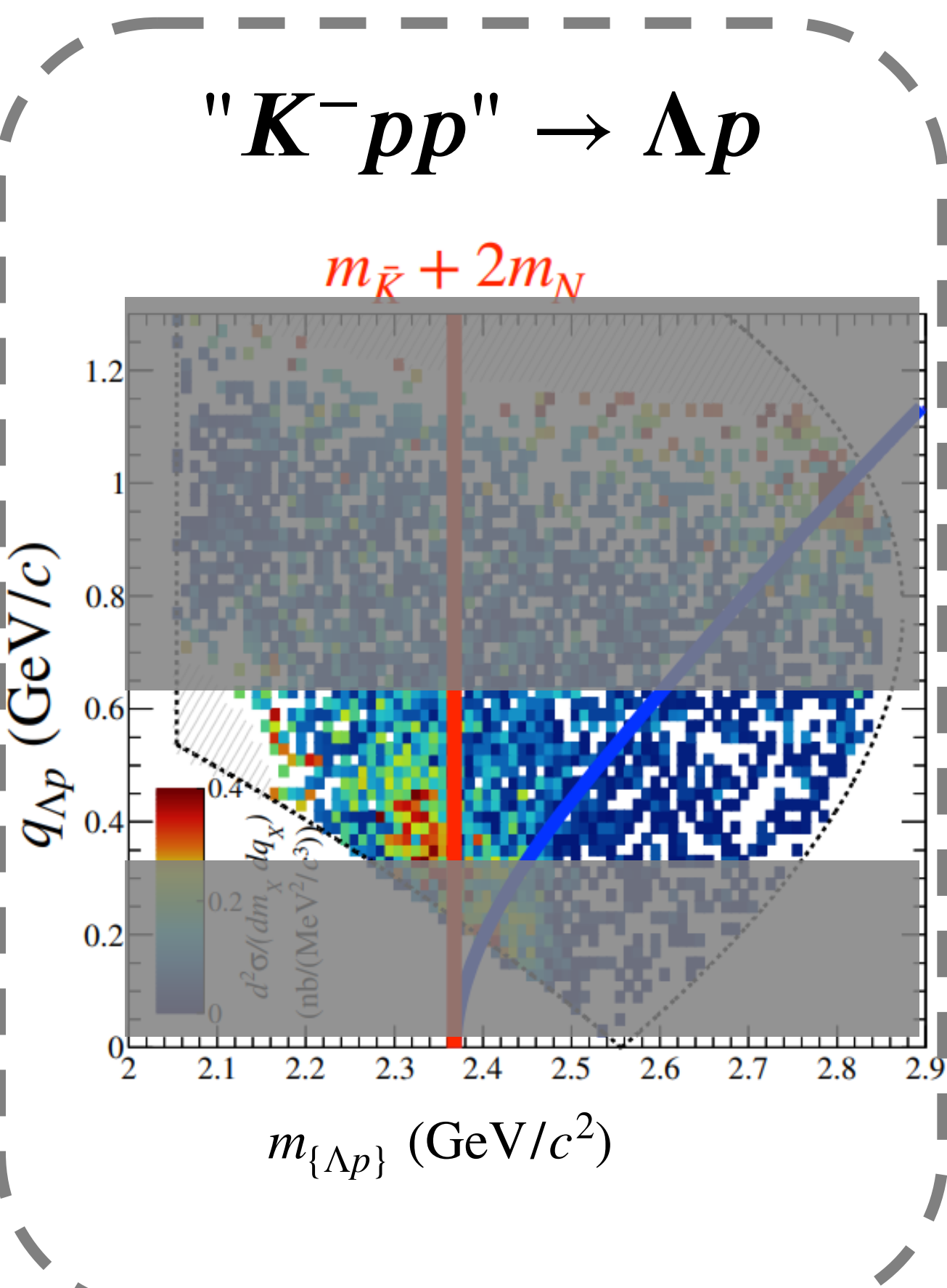

Fit the 1D spectra in $0.3 < q < 0.6$ with the same model func.

Mesonic Decay Analysis (with the E15 Data)

Plane Wave Impulse Approximation
Fit with PWIA $\sigma(M, q) \propto \rho(M, q) \times \frac{(\Gamma_{Kpp}/2)^2}{(M - M_{Kpp})^2 + (\Gamma_{Kpp}/2)^2} \times \exp\left(-\frac{q^2}{Q_{Kpp}^2}\right)$

Phase space
 Energy term (BW type) from time integral
 Momentum term from spatial integral

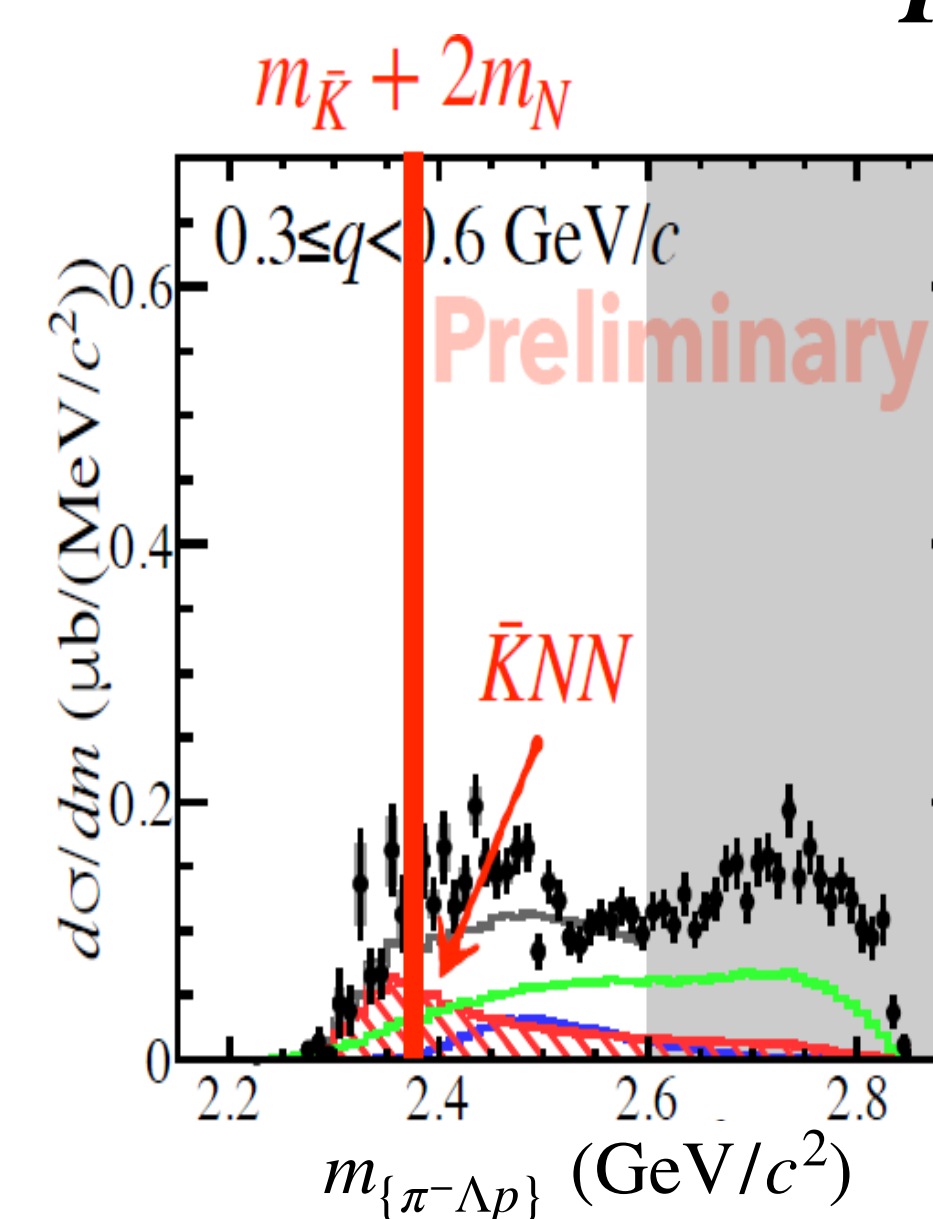
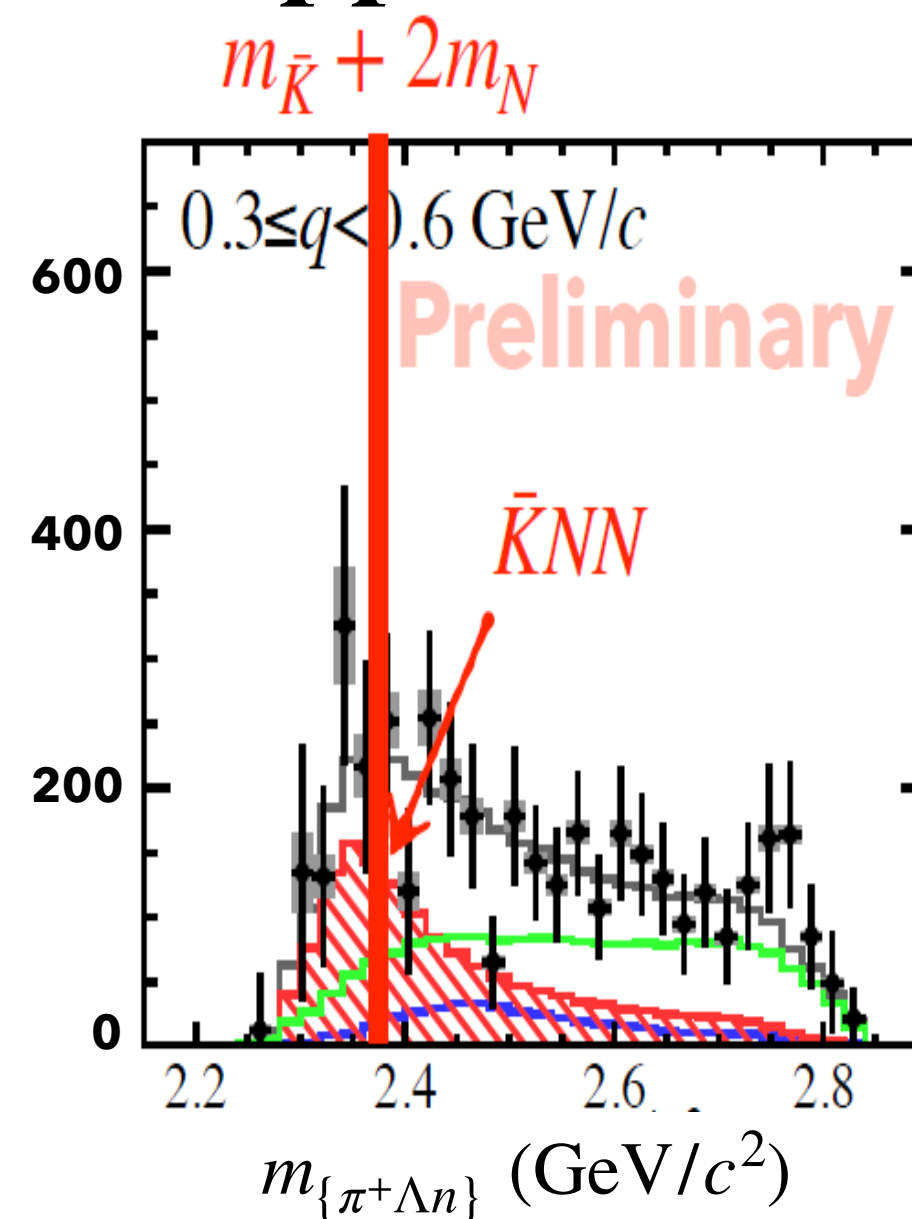
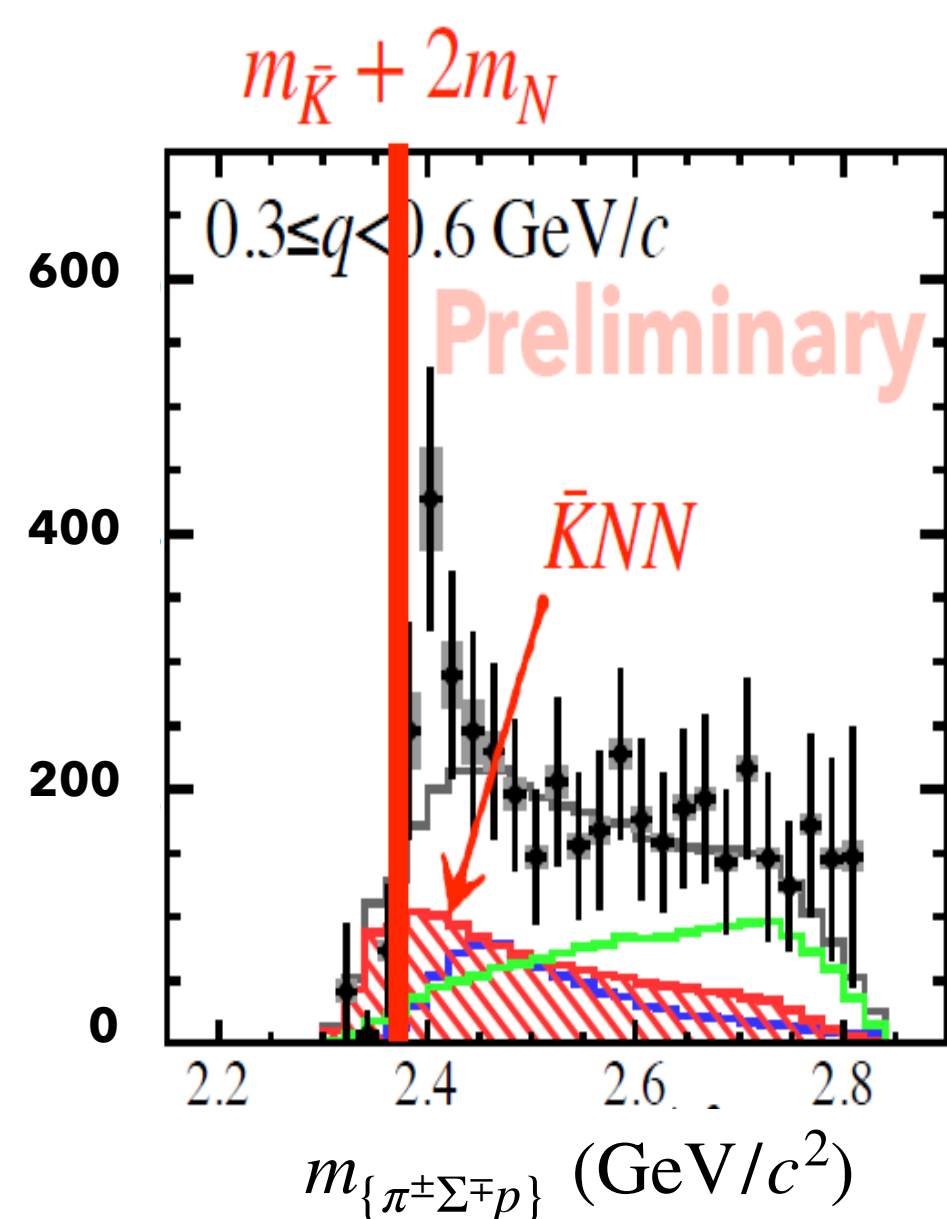
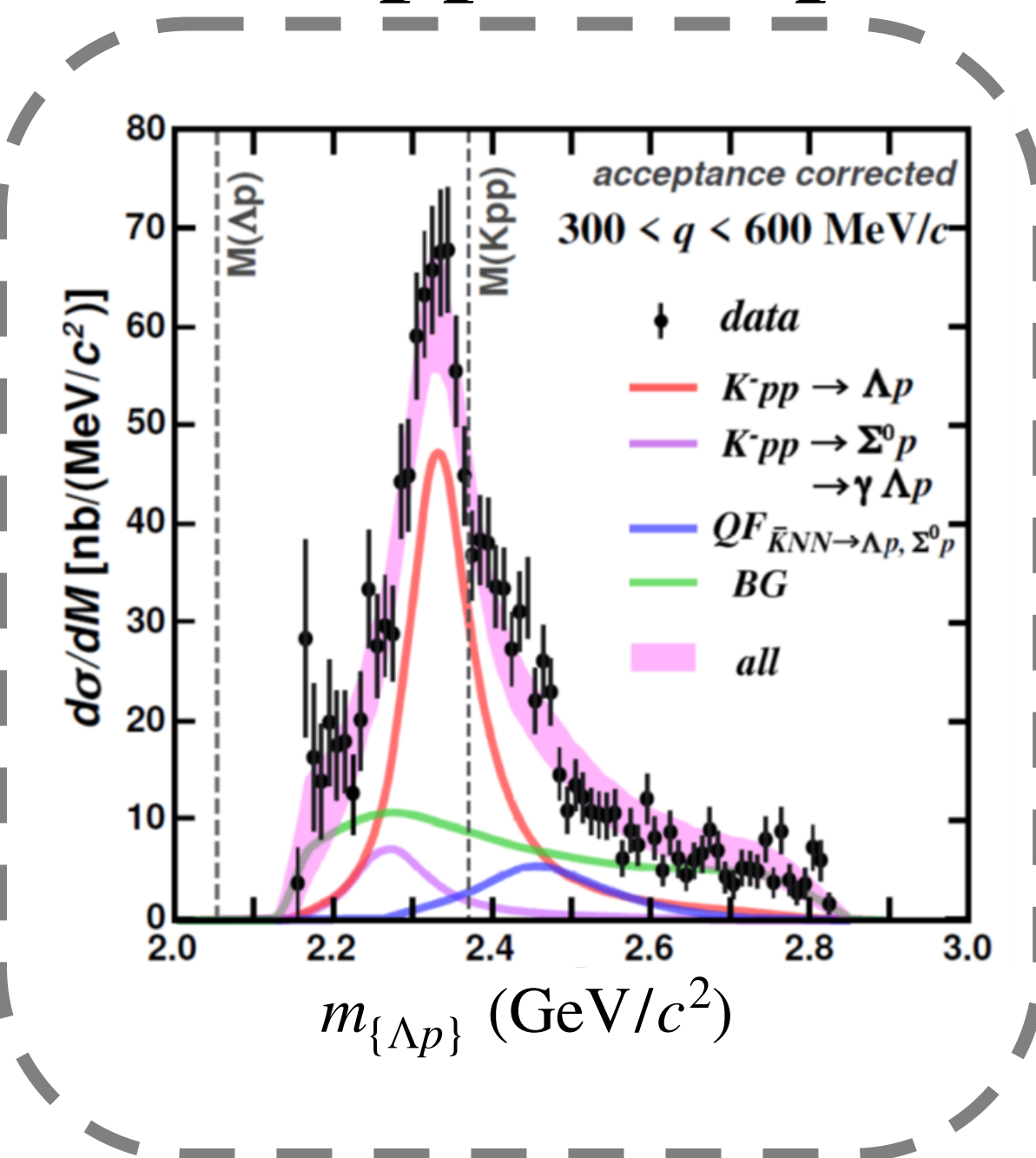
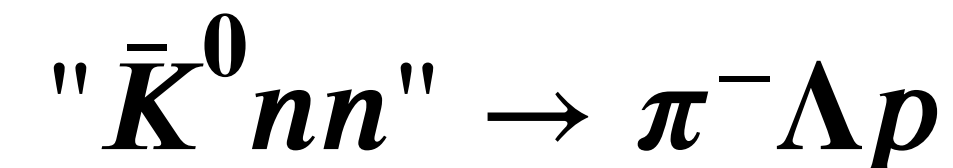
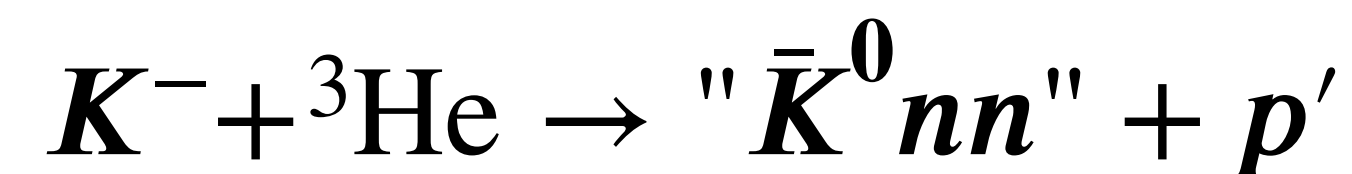
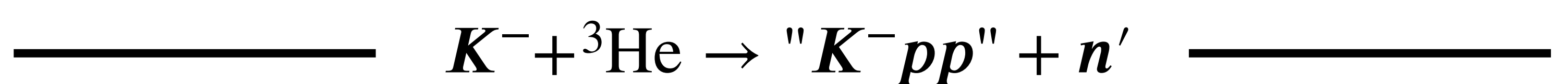

With the model func., the spectra are consistently explained.

Mesonic Decay (suppressed by the 4-body phase space)



$$\sigma_{\bar{K}NN}^{tot} \times Br (\mu b) =$$

$$9.3 \pm 0.8_{-1.0}^{+1.4} \text{ [all]}$$

$$5.5 \pm 0.5_{-0.6}^{+0.8} \text{ [<M(KNN)]}$$

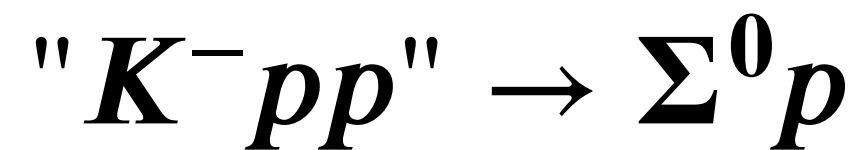

$$\sigma_{\bar{K}NN}^{tot} \times Br (\mu b) =$$

$$5.3 \pm 0.4_{-0.6}^{+0.8} \text{ [all]}$$

$$3.1 \pm 0.2_{-0.4}^{+0.5} \text{ [<M(KNN)]}$$

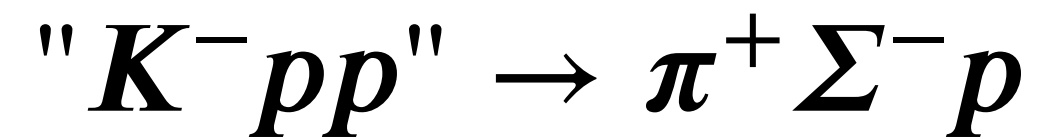

$$\sigma_{\bar{K}NN}^{tot} \times Br (\mu b) =$$

$$38 \pm 3 \pm 3 \text{ [all]}$$

$$3.2 \pm 0.2 \pm 0.2 \text{ [<M(KNN)]}$$

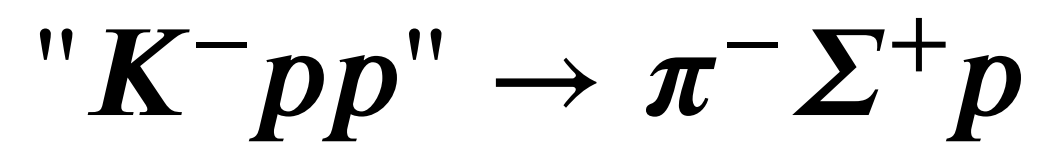

$$\sigma_{\bar{K}NN}^{tot} \times Br (\mu b) =$$

$$110 \pm 8 \pm 8 \text{ [all]}$$

$$9.4 \pm 0.4 \pm 0.7 \text{ [<M(KNN)]}$$

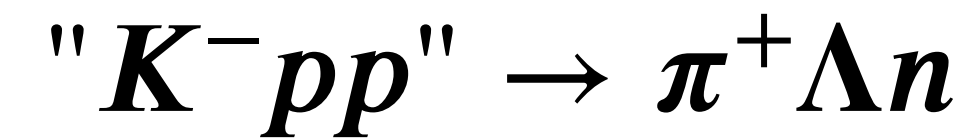

$$\sigma_{\bar{K}NN}^{tot} \times Br (\mu b) =$$

$$62 \pm 11 \pm 9 \text{ [all]}$$

$$15.5 \pm 2.7 \pm 2.1 \text{ [<M(KNN)]}$$

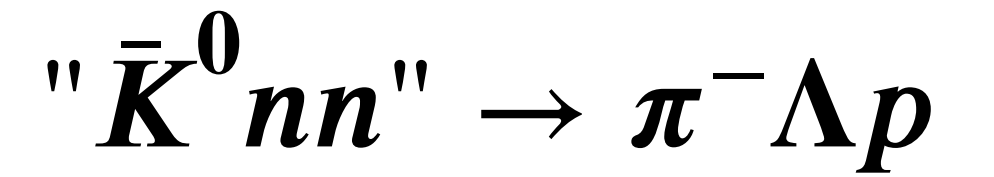

$$\sigma_{\bar{K}NN}^{tot} \times Br (\mu b) =$$

$$29 \pm 3 \pm 3 \text{ [all]}$$

$$7.2 \pm 0.6 \pm 0.7 \text{ [<M(KNN)]}$$

Mesonic Decay (suppressed by the 4-body phase space)

- $\Gamma_{YN} < \Gamma_{\pi YN}$: mesonic decay is dominant (about ~ 10 times in total)



$$\sigma_{\bar{K}NN}^{tot} \times Br (\mu b) =$$

$$9.3 \pm 0.8^{+1.4}_{-1.0} \text{ [all]}$$

$$5.5 \pm 0.5^{+0.8}_{-0.6} \text{ [<M(KNN)]}$$

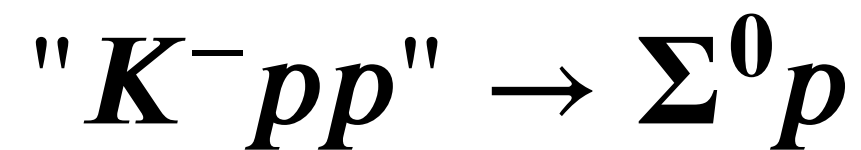

$$\sigma_{\bar{K}NN}^{tot} \times Br (\mu b) =$$

$$5.3 \pm 0.4^{+0.8}_{-0.6} \text{ [all]}$$

$$3.1 \pm 0.2^{+0.5}_{-0.4} \text{ [<M(KNN)]}$$

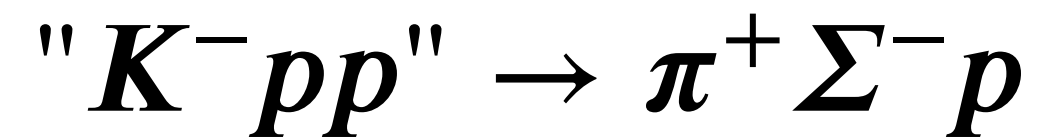

$$\sigma_{\bar{K}NN}^{tot} \times Br (\mu b) =$$

$$38 \pm 3 \pm 3 \text{ [all]}$$

$$3.2 \pm 0.2 \pm 0.2 \text{ [<M(KNN)]}$$

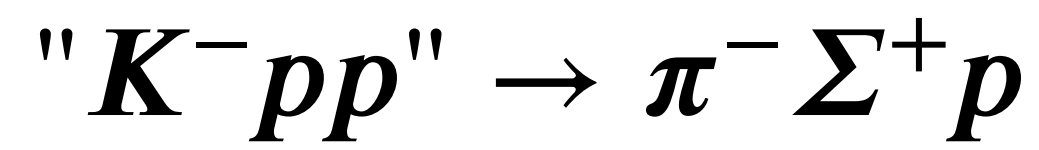

$$\sigma_{\bar{K}NN}^{tot} \times Br (\mu b) =$$

$$110 \pm 8 \pm 8 \text{ [all]}$$

$$9.4 \pm 0.4 \pm 0.7 \text{ [<M(KNN)]}$$

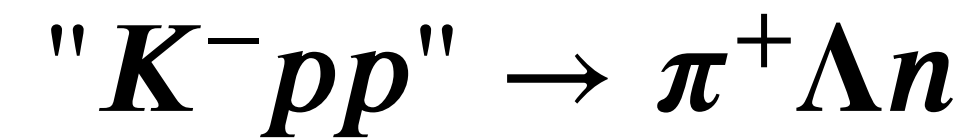

$$\sigma_{\bar{K}NN}^{tot} \times Br (\mu b) =$$

$$62 \pm 11 \pm 9 \text{ [all]}$$

$$15.5 \pm 2.7 \pm 2.1 \text{ [<M(KNN)]}$$

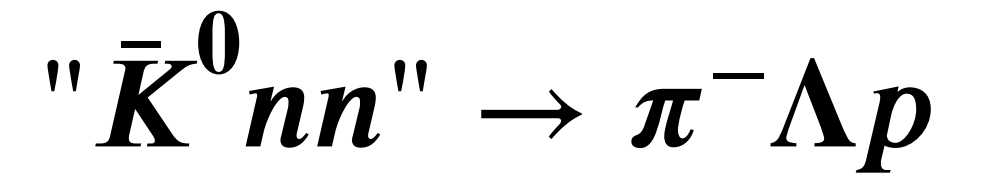

$$\sigma_{\bar{K}NN}^{tot} \times Br (\mu b) =$$

$$29 \pm 3 \pm 3 \text{ [all]}$$

$$7.2 \pm 0.6 \pm 0.7 \text{ [<M(KNN)]}$$

Mesonic Decay (suppressed by the 4-body phase space)

- $\Gamma_{YN} < \Gamma_{\pi YN}$: mesonic decay is dominant (about ~ 10 times in total)
- $\Gamma_{\pi\Sigma N} \sim \Gamma_{\pi\Lambda N}$: significant contribution of the $I_{\bar{K}N} = 1$ as well as $I_{\bar{K}N} = 0$



$$\sigma_{\bar{K}NN}^{tot} \times Br (\mu b) =$$

$$9.3 \pm 0.8^{+1.4}_{-1.0} \text{ [all]}$$

$$5.5 \pm 0.5^{+0.8}_{-0.6} \text{ [<M(KNN)]}$$

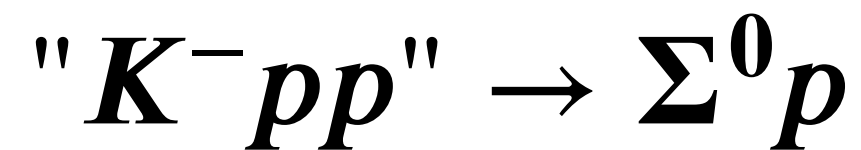

$$\sigma_{\bar{K}NN}^{tot} \times Br (\mu b) =$$

$$5.3 \pm 0.4^{+0.8}_{-0.6} \text{ [all]}$$

$$3.1 \pm 0.2^{+0.5}_{-0.4} \text{ [<M(KNN)]}$$

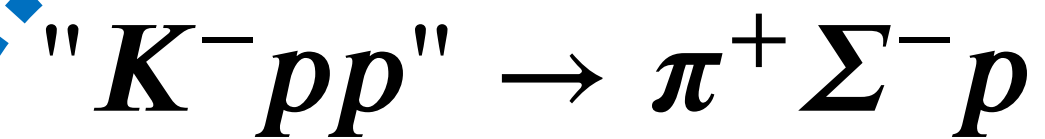

$$\sigma_{\bar{K}NN}^{tot} \times Br (\mu b) =$$

$$38 \pm 3 \pm 3 \text{ [all]}$$

$$3.2 \pm 0.2 \pm 0.2 \text{ [<M(KNN)]}$$

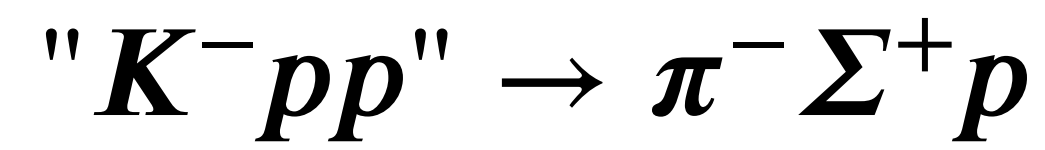

$$\sigma_{\bar{K}NN}^{tot} \times Br (\mu b) =$$

$$110 \pm 8 \pm 8 \text{ [all]}$$

$$9.4 \pm 0.4 \pm 0.7 \text{ [<M(KNN)]}$$

$$I_{\bar{K}N} = 0 \text{ or } 1$$

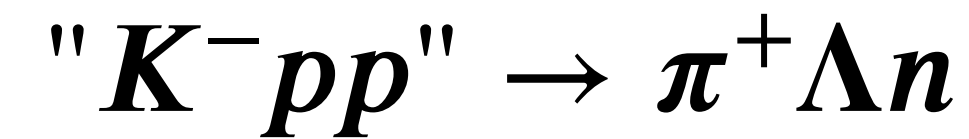

$$\sigma_{\bar{K}NN}^{tot} \times Br (\mu b) =$$

$$62 \pm 11 \pm 9 \text{ [all]}$$

$$15.5 \pm 2.7 \pm 2.1 \text{ [<M(KNN)]}$$

$$I_{\bar{K}N} = 1$$

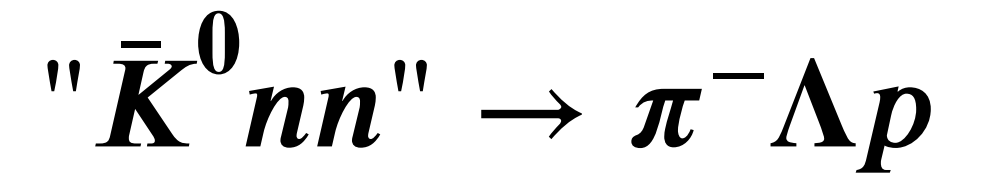

$$\sigma_{\bar{K}NN}^{tot} \times Br (\mu b) =$$

$$29 \pm 3 \pm 3 \text{ [all]}$$

$$7.2 \pm 0.6 \pm 0.7 \text{ [<M(KNN)]}$$

Mesonic Decay (suppressed by the 4-body phase space)

- $\Gamma_{YN} < \Gamma_{\pi YN}$: mesonic decay is dominant (about ~ 10 times in total)
- $\Gamma_{\pi\Sigma N} \sim \Gamma_{\pi\Lambda N}$: significant contribution of the $I_{\bar{K}N} = 1$ as well as $I_{\bar{K}N} = 0$
- $\Gamma_{\pi^+\Lambda n} / \Gamma_{\pi^-\Lambda p} \sim 2$: if we assume $Br_{\{K^-pp\} \rightarrow \pi^+\Lambda p} / Br_{\{\bar{K}^0nn\} \rightarrow \pi^-\Lambda p} \approx 1$ & $\sigma_{\{K^-pp\}} / \sigma_{\{\bar{K}^0nn\}} \approx 2$



$$\sigma_{\bar{K}NN}^{tot} \times Br (\mu b) =$$

$$9.3 \pm 0.8_{-1.0}^{+1.4} \text{ [all]}$$

$$5.5 \pm 0.5_{-0.6}^{+0.8} \text{ [<M(KNN)]}$$

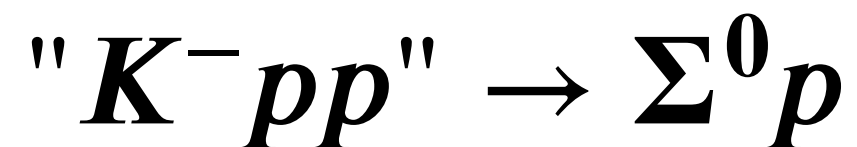

$$\sigma_{\bar{K}NN}^{tot} \times Br (\mu b) =$$

$$5.3 \pm 0.4_{-0.6}^{+0.8} \text{ [all]}$$

$$3.1 \pm 0.2_{-0.4}^{+0.5} \text{ [<M(KNN)]}$$

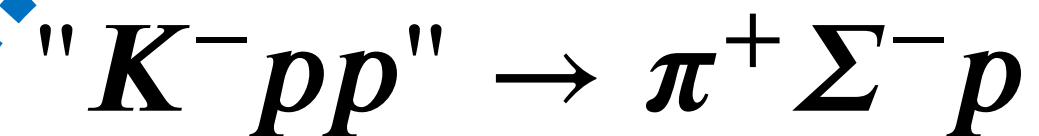

$$\sigma_{\bar{K}NN}^{tot} \times Br (\mu b) =$$

$$38 \pm 3 \pm 3 \text{ [all]}$$

$$3.2 \pm 0.2 \pm 0.2 \text{ [<M(KNN)]}$$

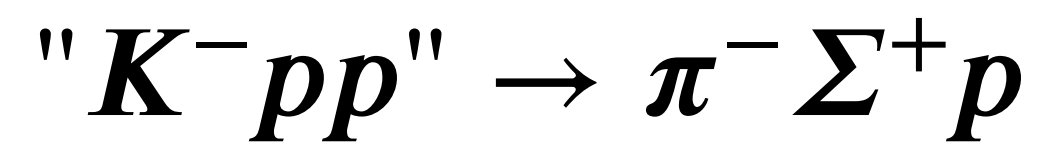

$$\sigma_{\bar{K}NN}^{tot} \times Br (\mu b) =$$

$$110 \pm 8 \pm 8 \text{ [all]}$$

$$9.4 \pm 0.4 \pm 0.7 \text{ [<M(KNN)]}$$

$$I_{\bar{K}N} = 0 \text{ or } 1$$

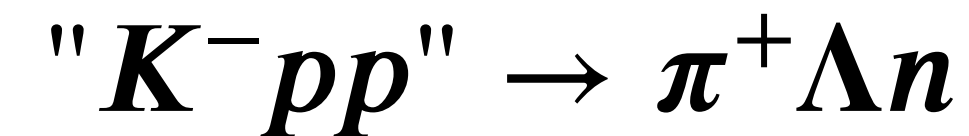

$$\sigma_{\bar{K}NN}^{tot} \times Br (\mu b) =$$

$$62 \pm 11 \pm 9 \text{ [all]}$$

$$15.5 \pm 2.7 \pm 2.1 \text{ [<M(KNN)]}$$

$$I_{\bar{K}N} = 1$$

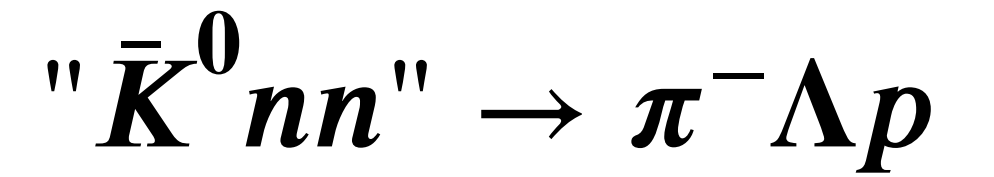

$$\sigma_{\bar{K}NN}^{tot} \times Br (\mu b) =$$

$$29 \pm 3 \pm 3 \text{ [all]}$$

$$7.2 \pm 0.6 \pm 0.7 \text{ [<M(KNN)]}$$

$$I_{\bar{K}N} = 1$$

Mesonic decay branch of $\bar{K}^0 nn$?

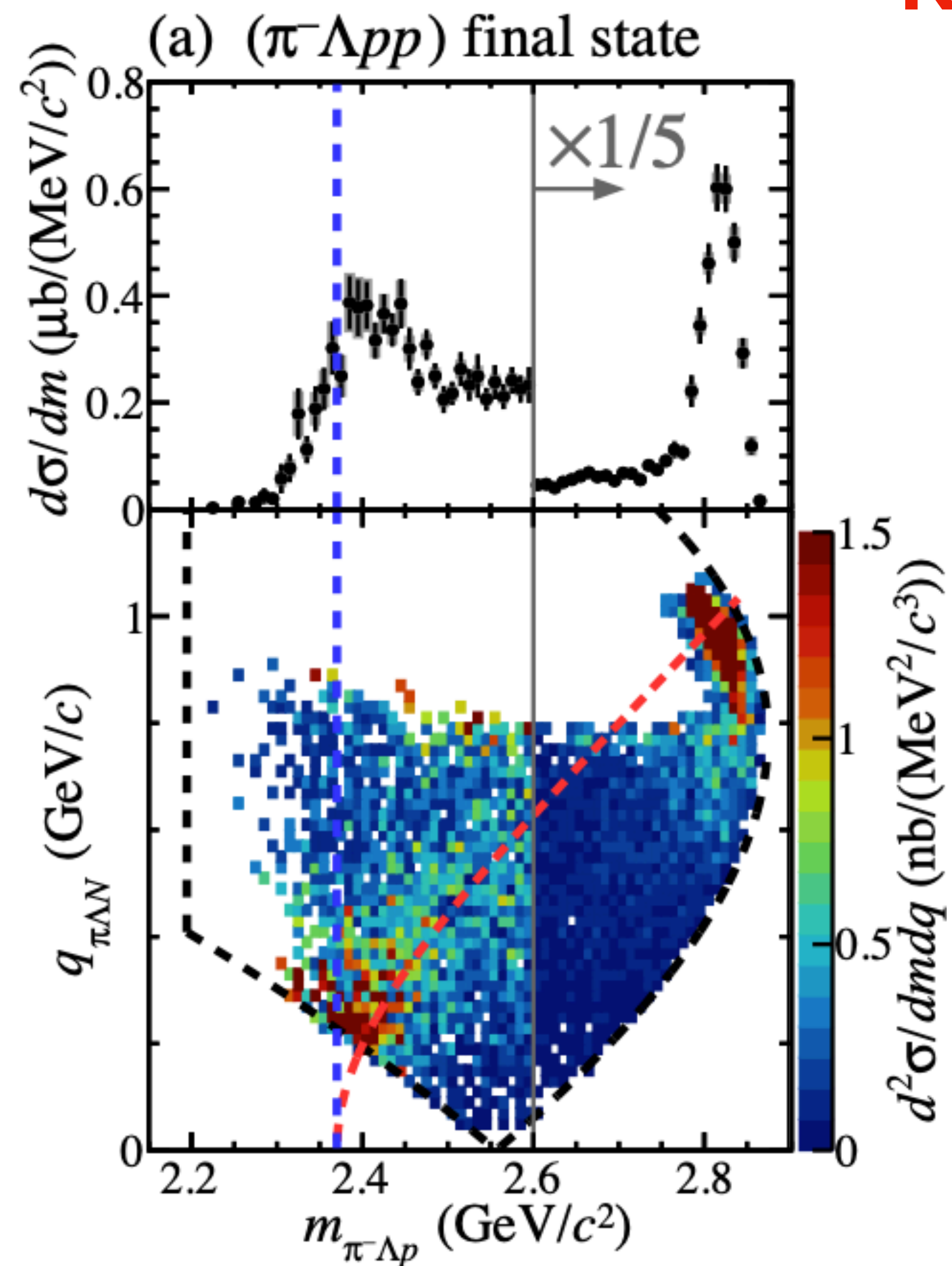
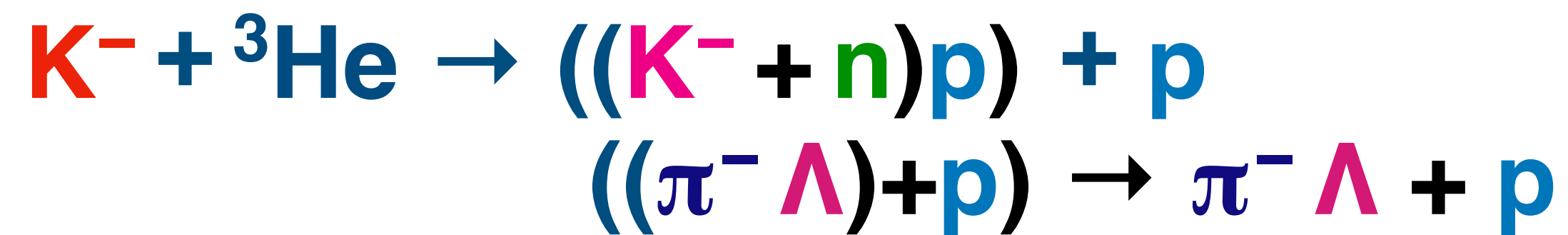

Mesonic decay branch of $\bar{K}^0 nn$?

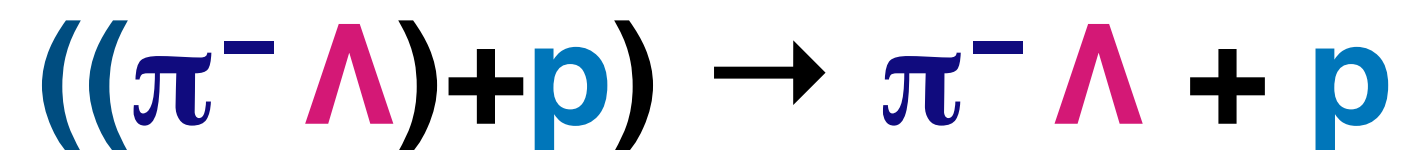

... but the *excess* is still not easy to see ...

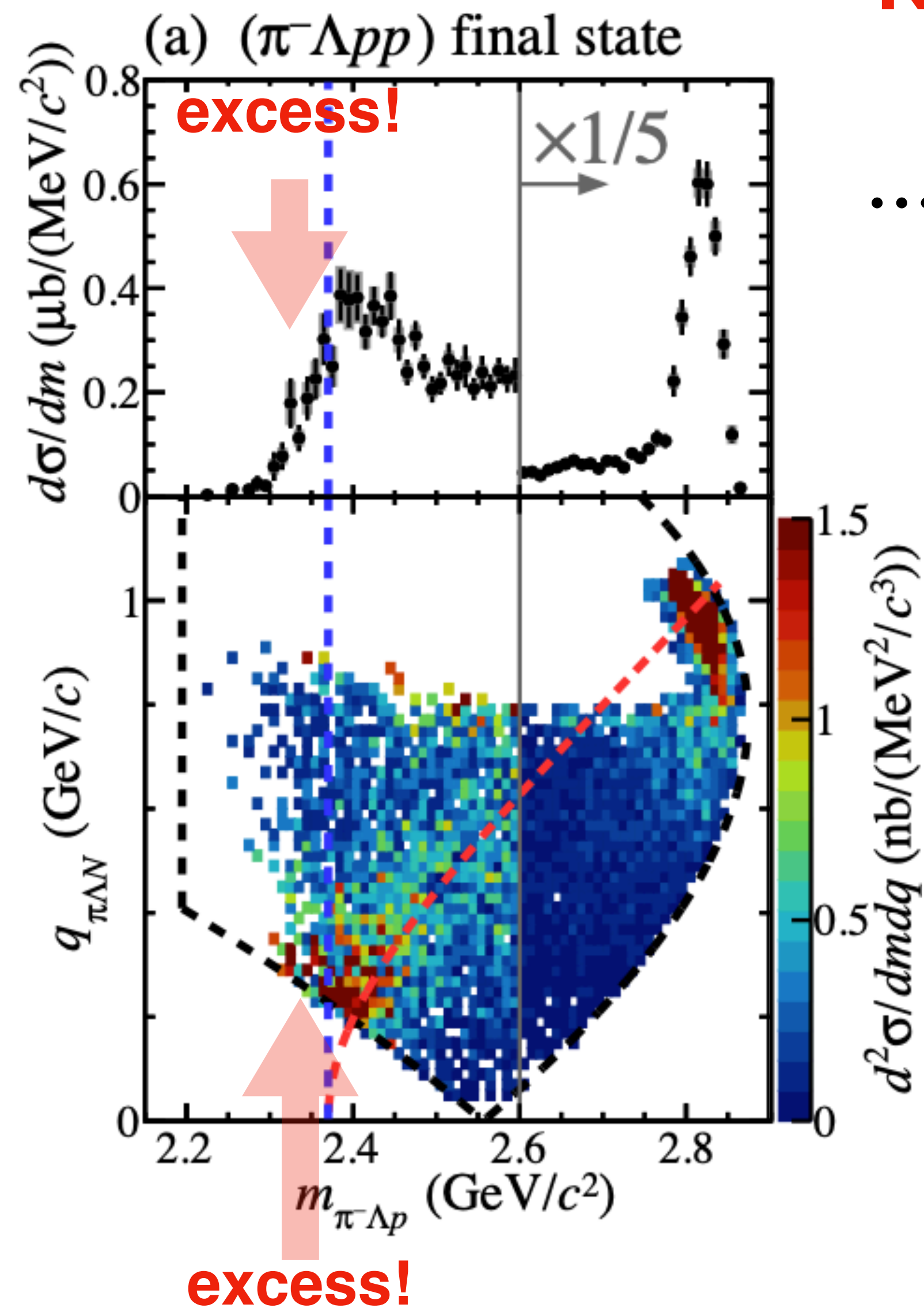

Mesonic decay branch of $\bar{K}^0 nn$?

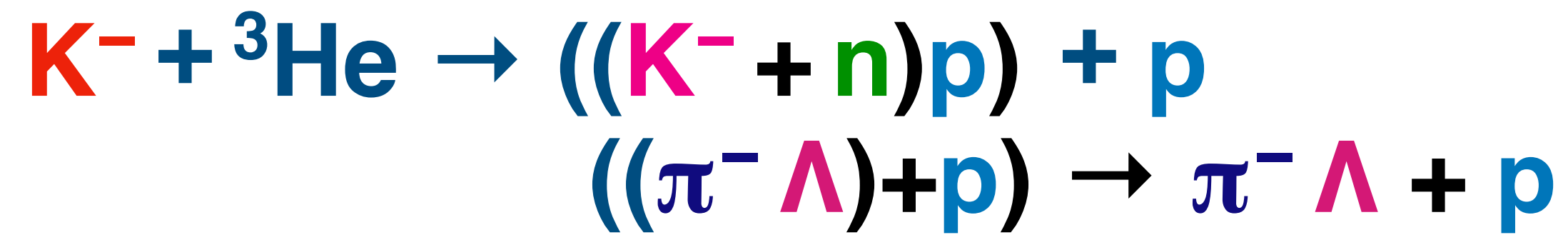

... but the *excess* is still not easy to see ... due to the *QF-K*

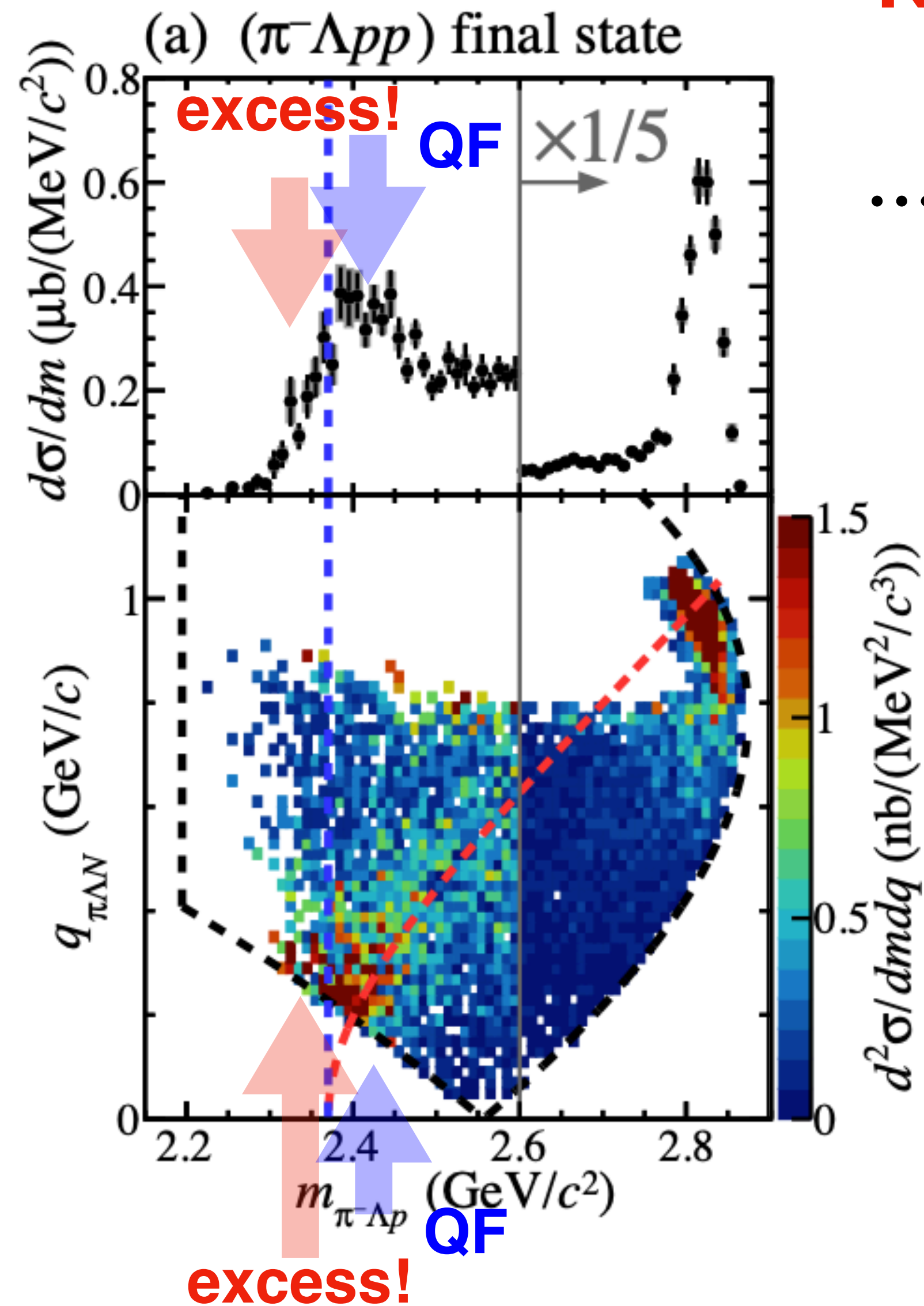

Mesonic decay branch of $\bar{K}^0 nn$?

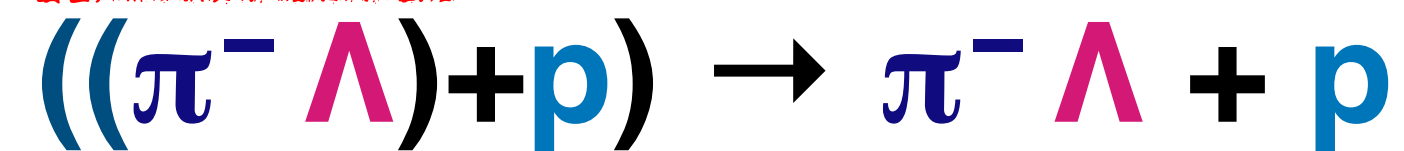

... but the *excess* is still not easy to see ... due to the *QF-K*

If $m_{\pi^- \Lambda} \geq m_{K^-} + m_n$, then the “*K⁻np*” bound state cannot be formed, but will form a quasi-free background.

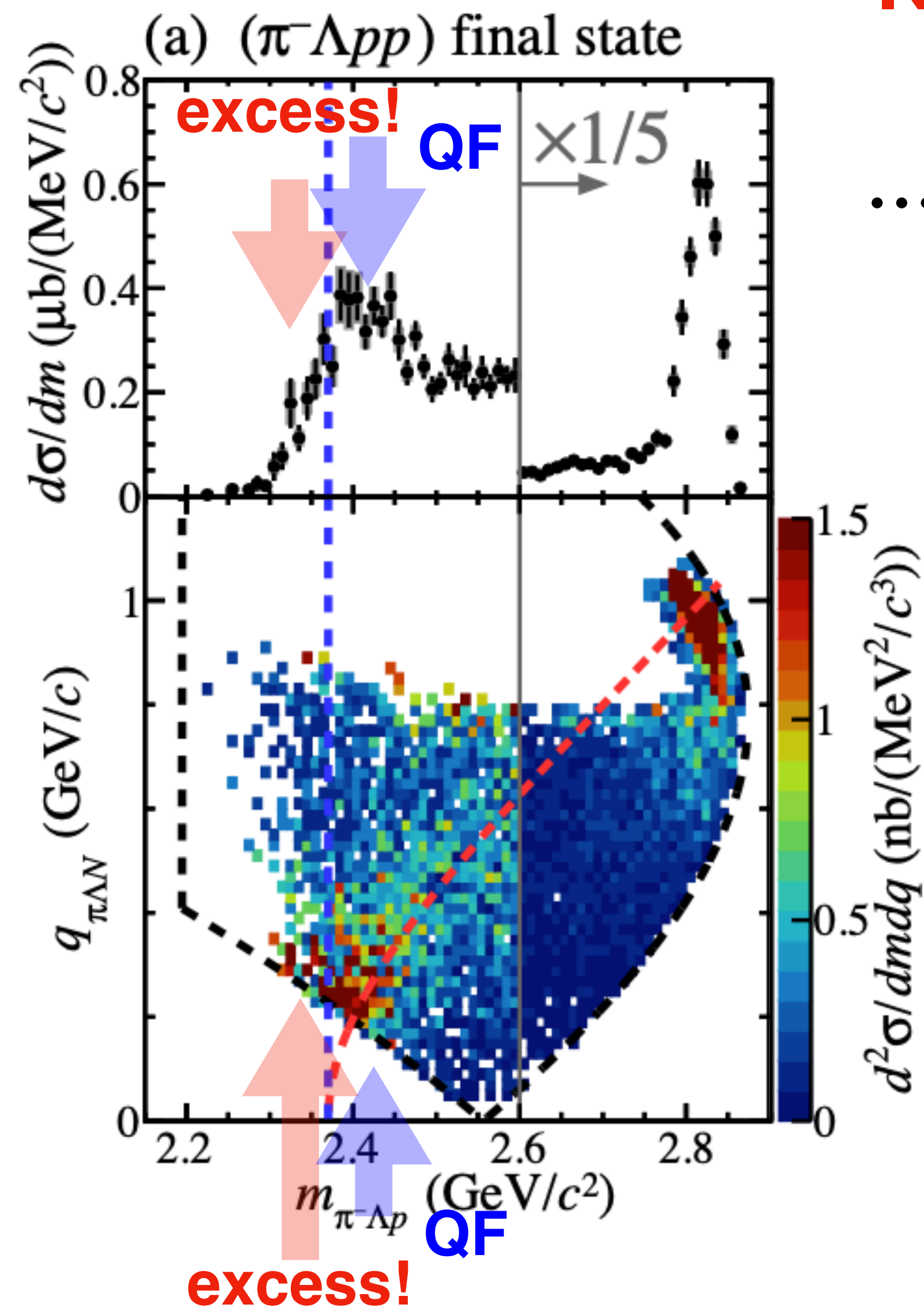

Mesonic decay branch of $\bar{K}^0 nn$?

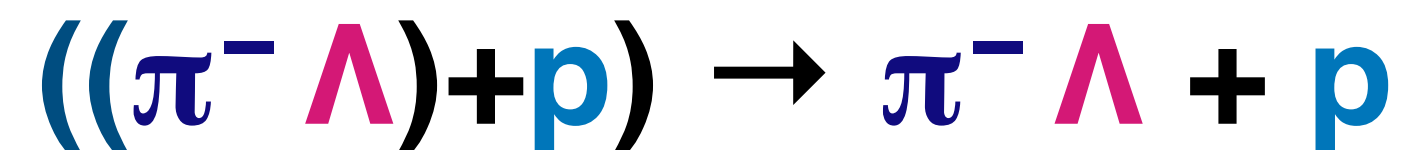

... but the *excess* is still not easy to see ... due to the *QF-K*

If $m_{\pi^- \Lambda} \geq m_{K^-} + m_n$, then the "*K⁻np*" bound state cannot be formed, but will form a quasi-free background.

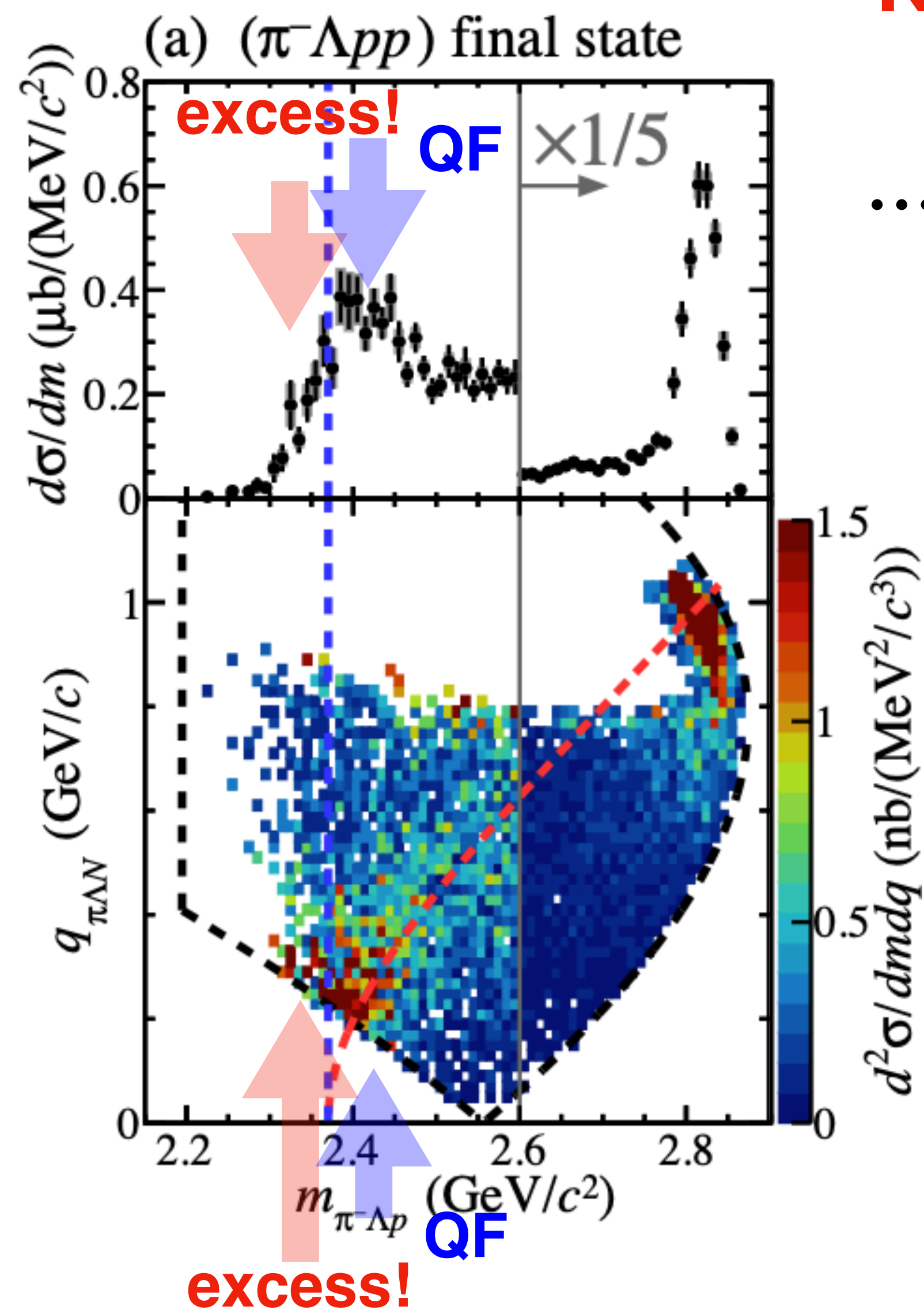

Mesonic decay branch of $\bar{K}^0 nn$?

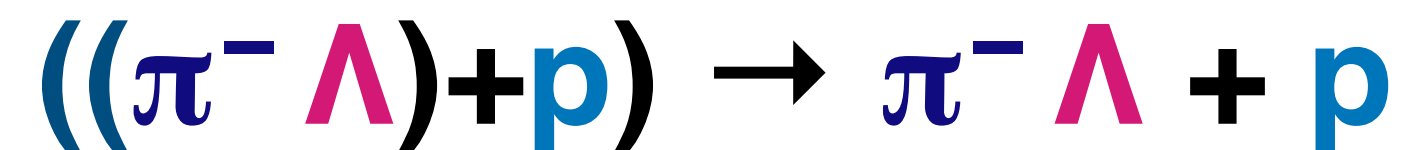

... but the *excess* is still not easy to see ... due to the *QF-K*

If $m_{\pi^- \Lambda} \geq m_{K^-} + m_n$, then the “ $K^- np$ ” bound state cannot be formed, but will form a quasi-free background.

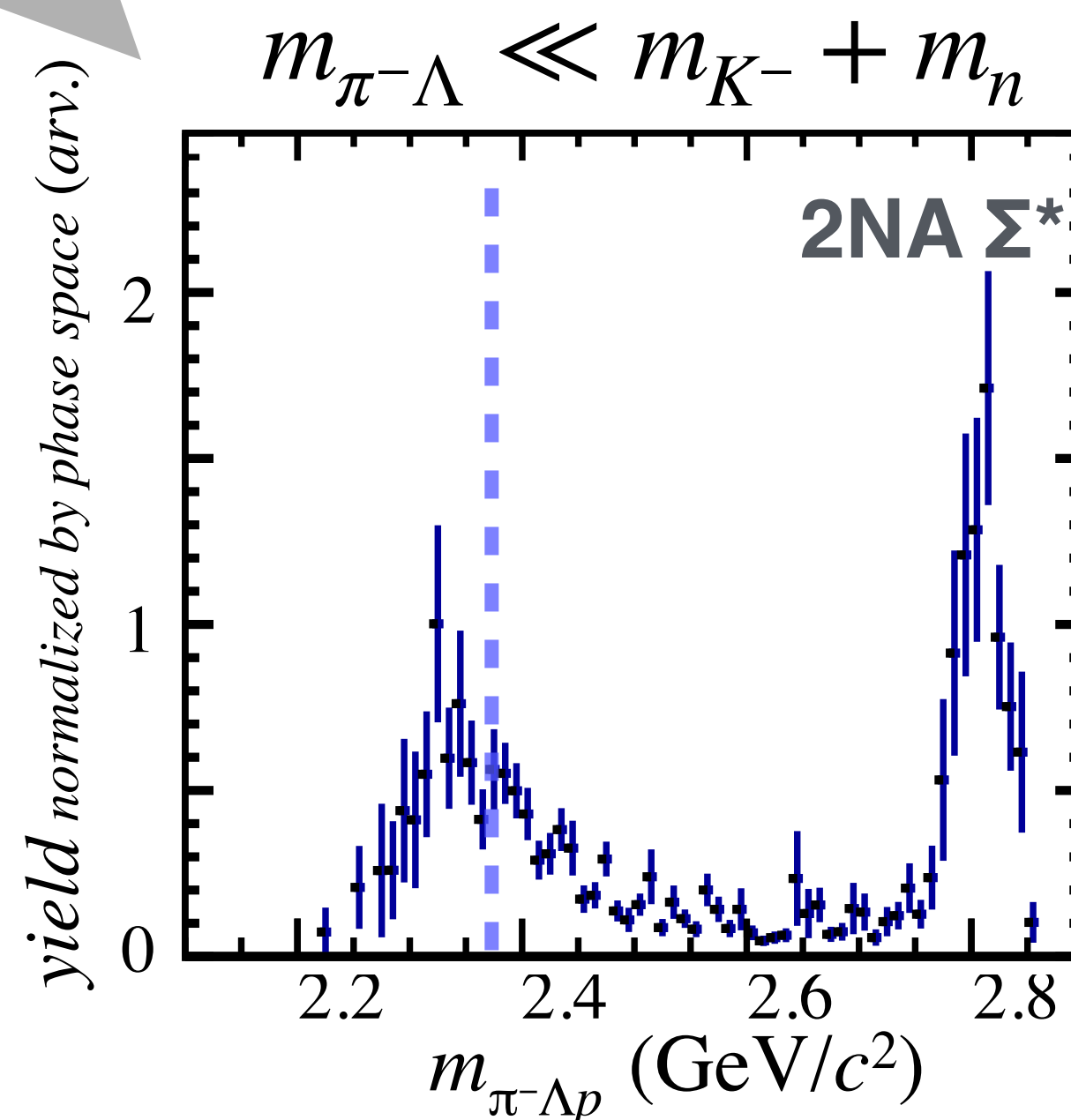
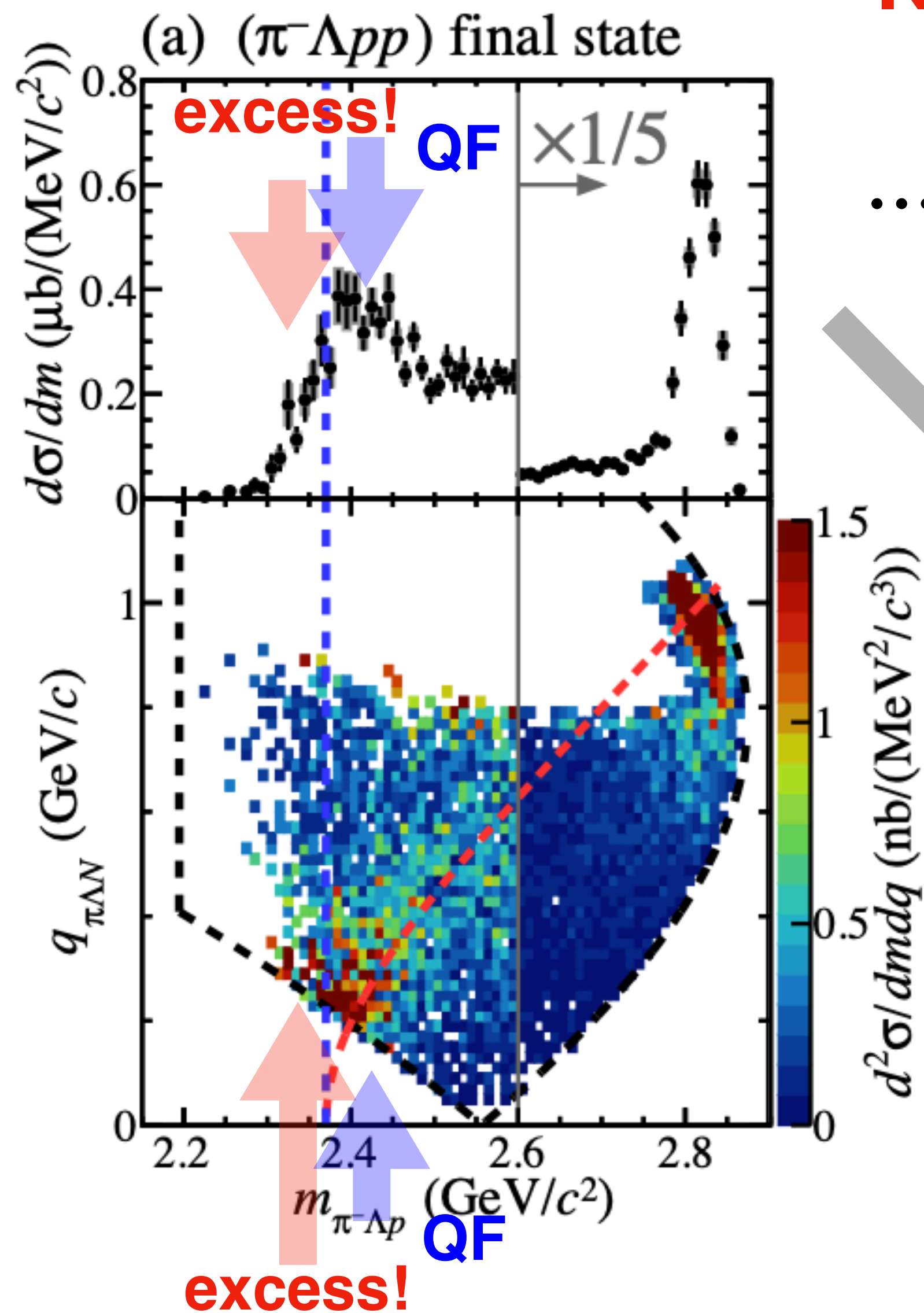

Mesonic decay branch of $\bar{K}^0 nn$?

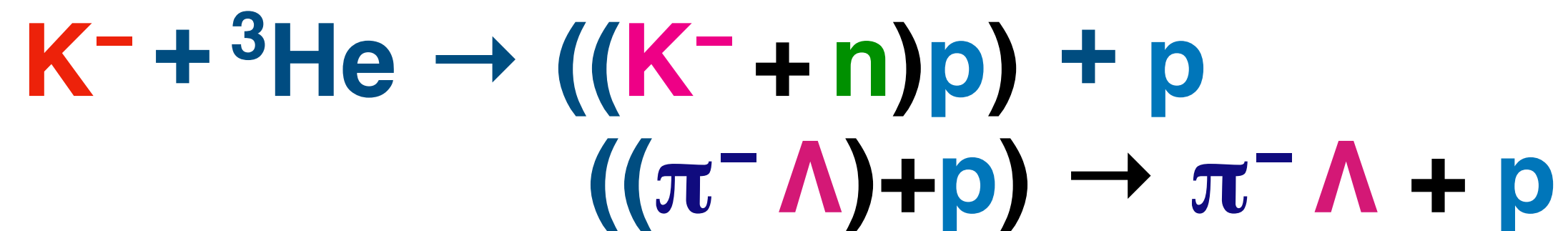

... but the *excess* is still not easy to see ... due to the *QF-K*

If $m_{\pi^- \Lambda} \geq m_{K^-} + m_n$, then the “ $K^- np$ ” bound state cannot be formed, but will form a quasi-free background.

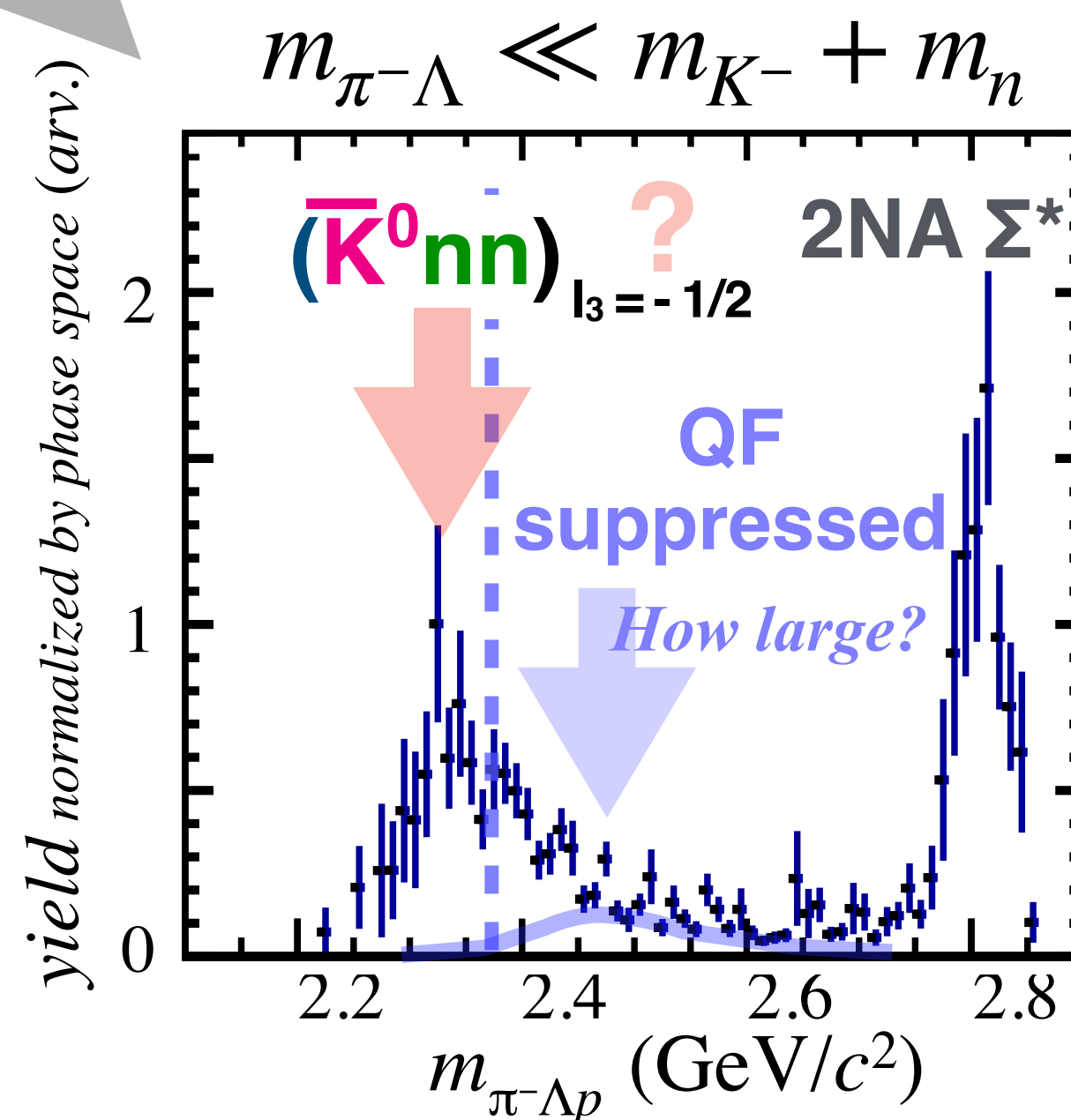
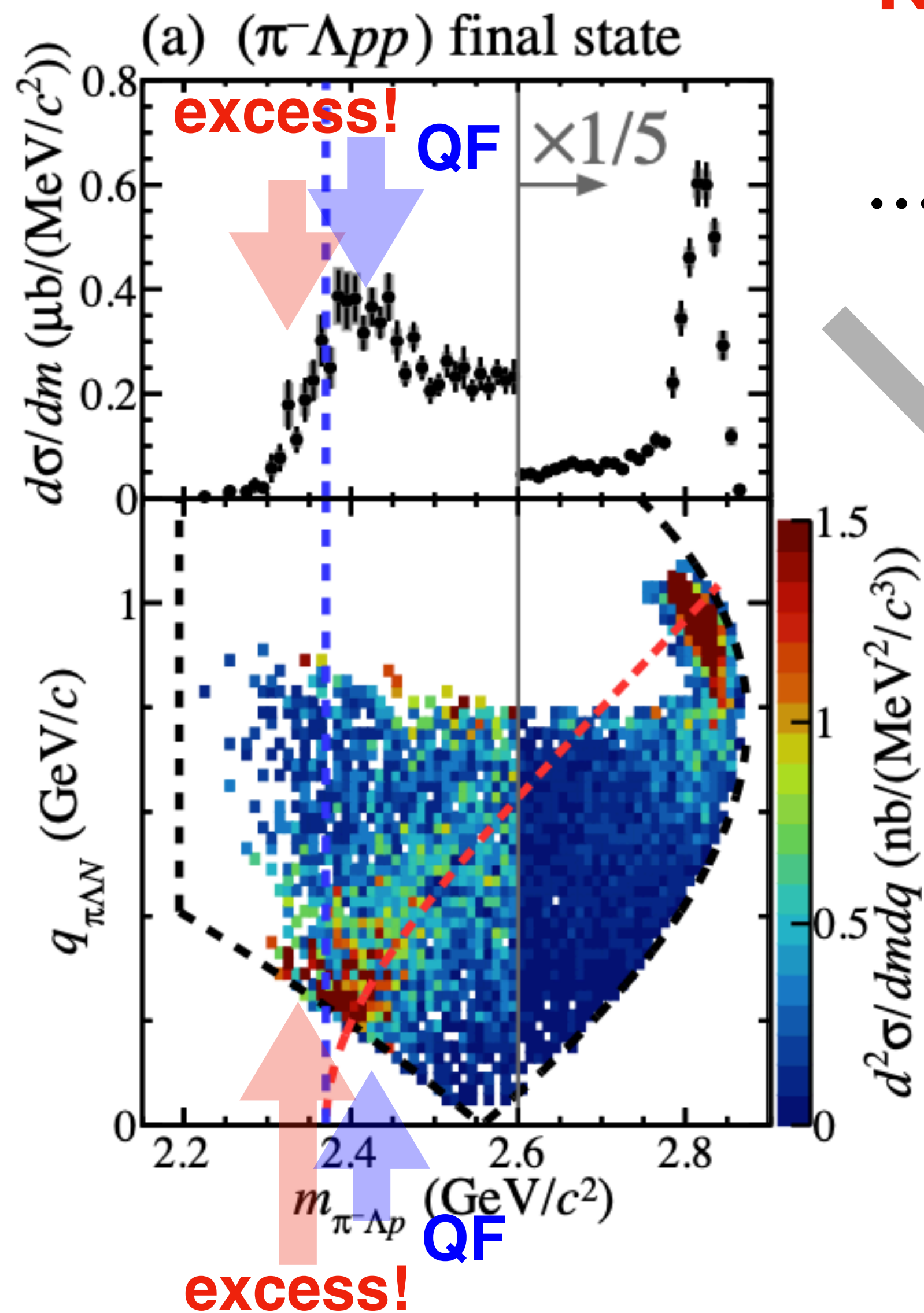

Why don't we normalize it by the *Phase Space*? It is very promising, but needs further verification.

Mesonic decay branch of $\bar{K}^0 nn$?

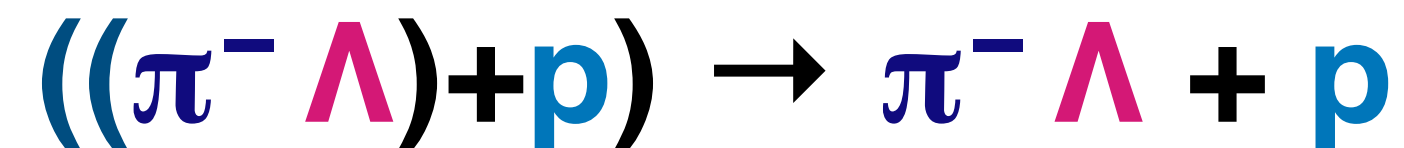

... but the *excess* is still not easy to see ... due to the *QF-K*

If $m_{\pi^- \Lambda} \geq m_{K^-} + m_n$, then the “ $K^- np$ ” bound state cannot be formed, but will form a quasi-free background.

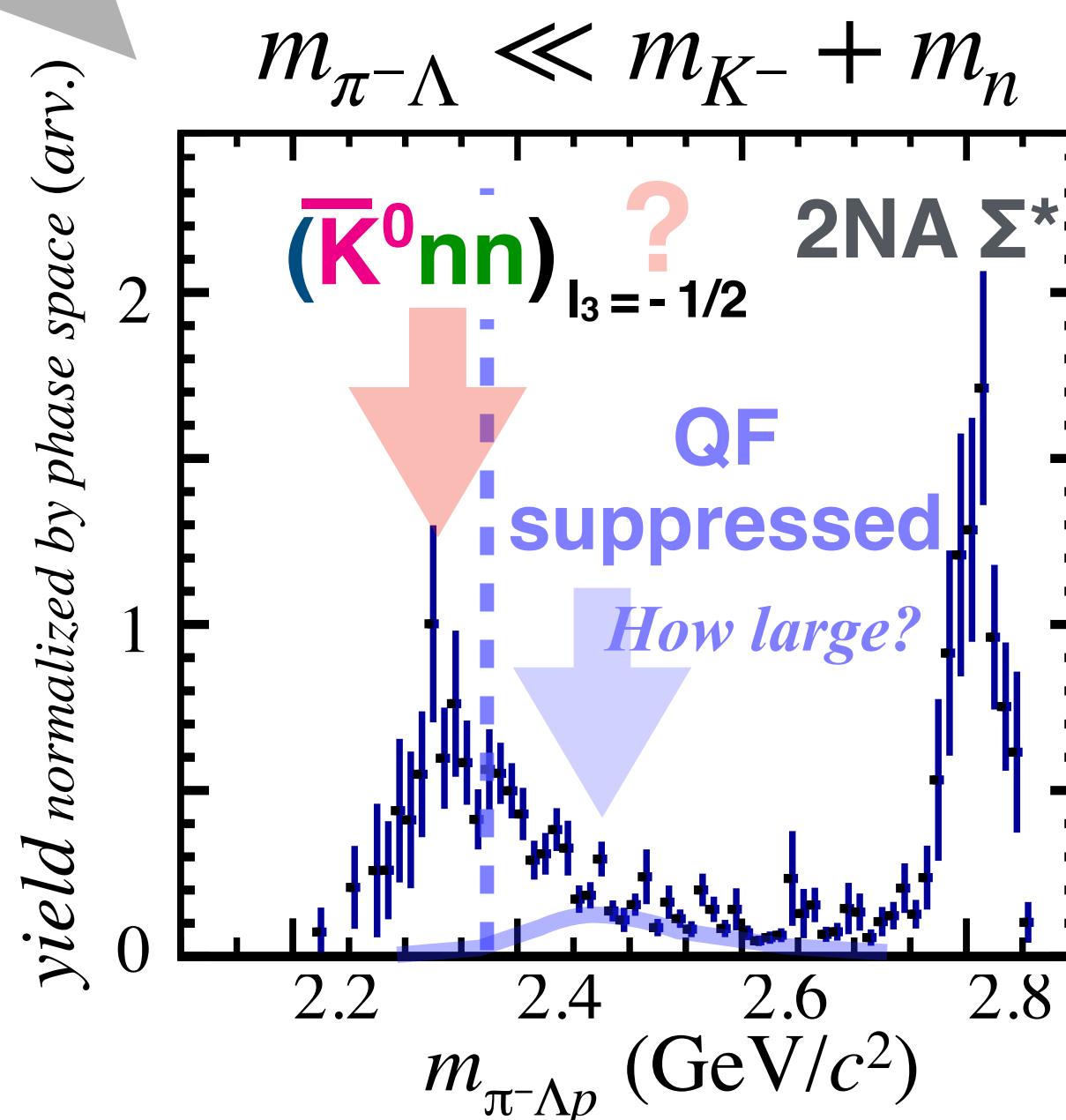
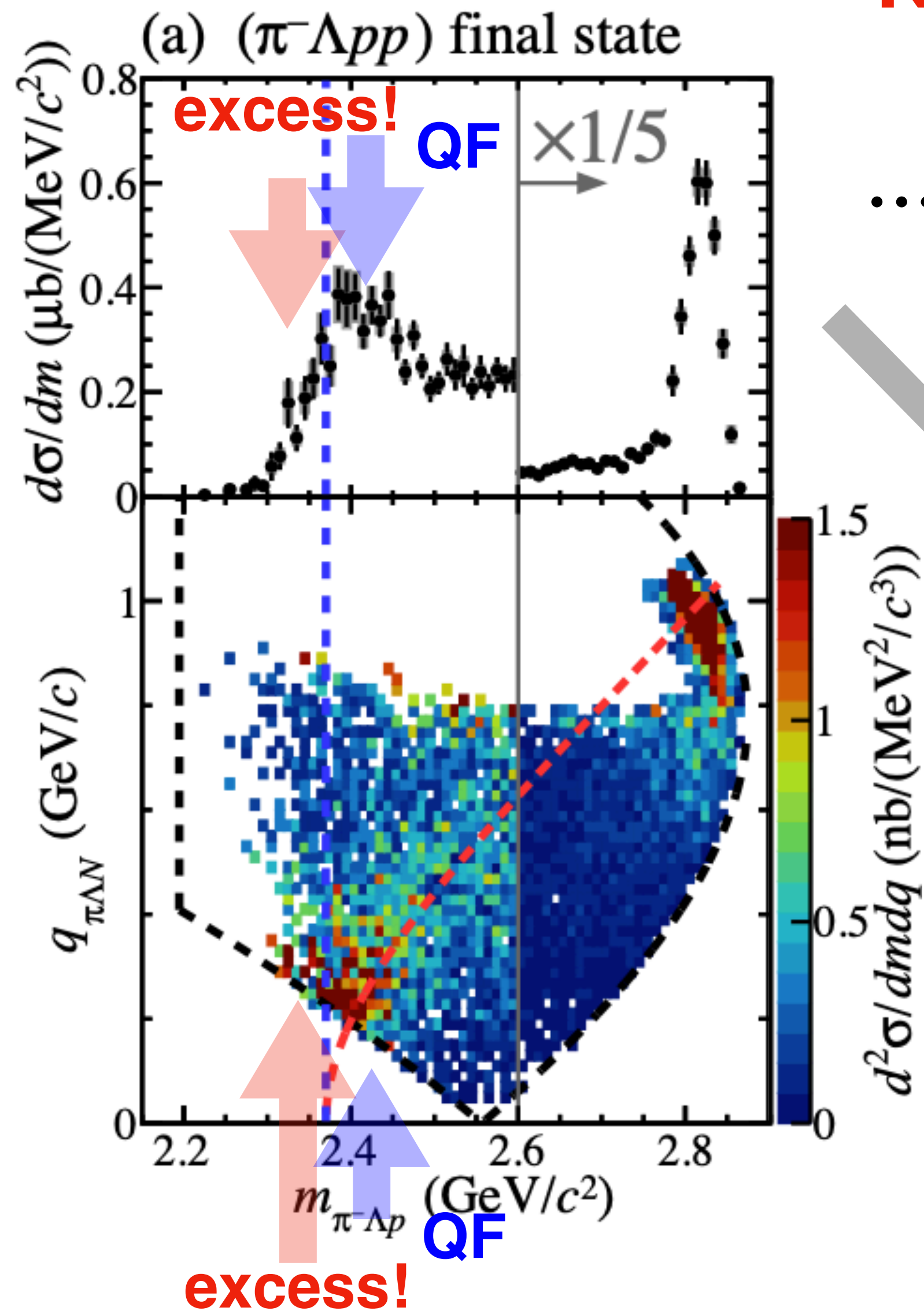

Why don't we normalize it by the *Phase Space*? It is very promising, but needs further verification.

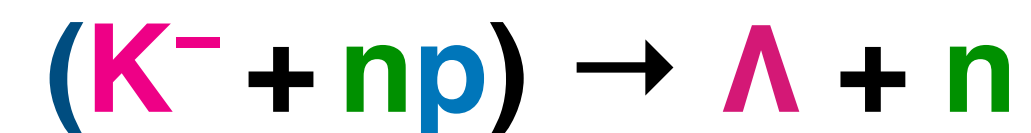

Mesonic decay branch of $\bar{K}^0 nn$?

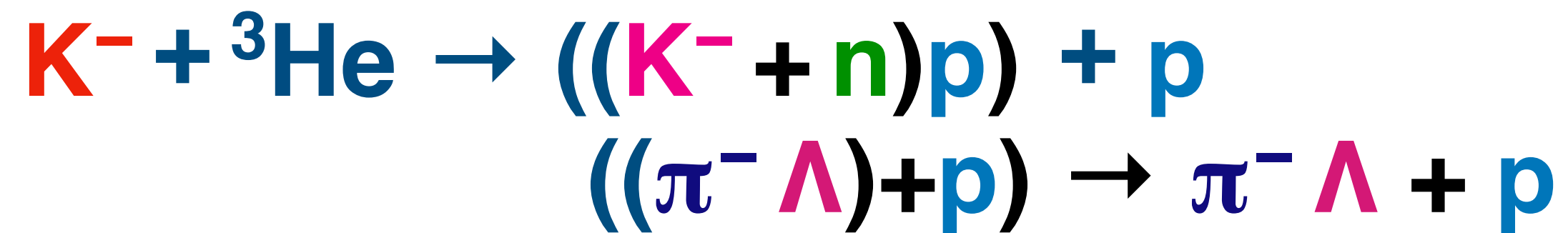

... but the *excess* is still not easy to see ... due to the *QF-K*

If $m_{\pi^- \Lambda} \geq m_{K^-} + m_n$, then the “ $\mathbf{K}^- \mathbf{np}$ ” bound state cannot be formed, but will form a quasi-free background.

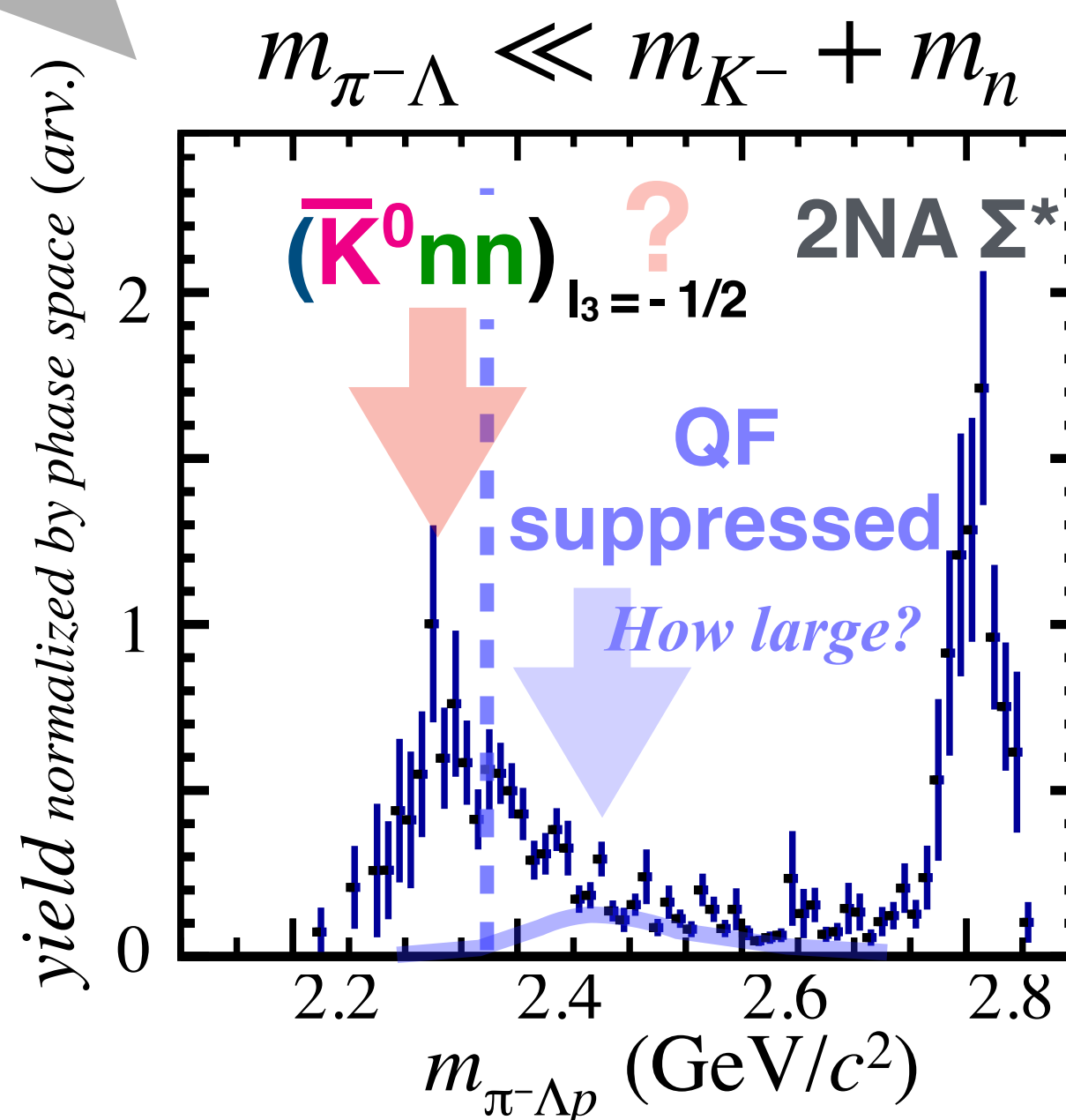
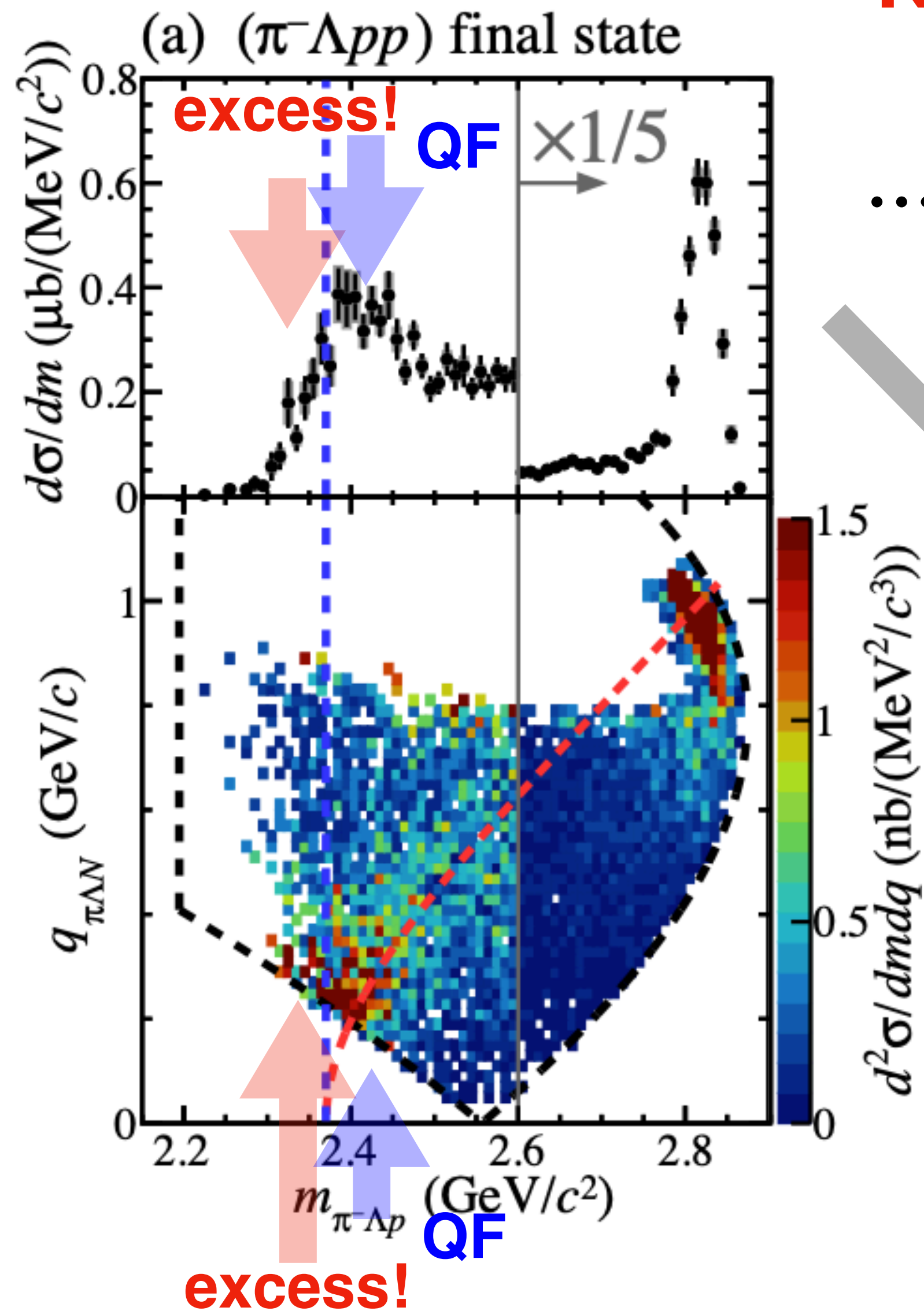

Why don't we normalize it by the *Phase Space*? It is very promising, but needs further verification.





Other materials

${}^3\text{He}(K^-, n_{\text{NC}})X$ – semi-inclusive

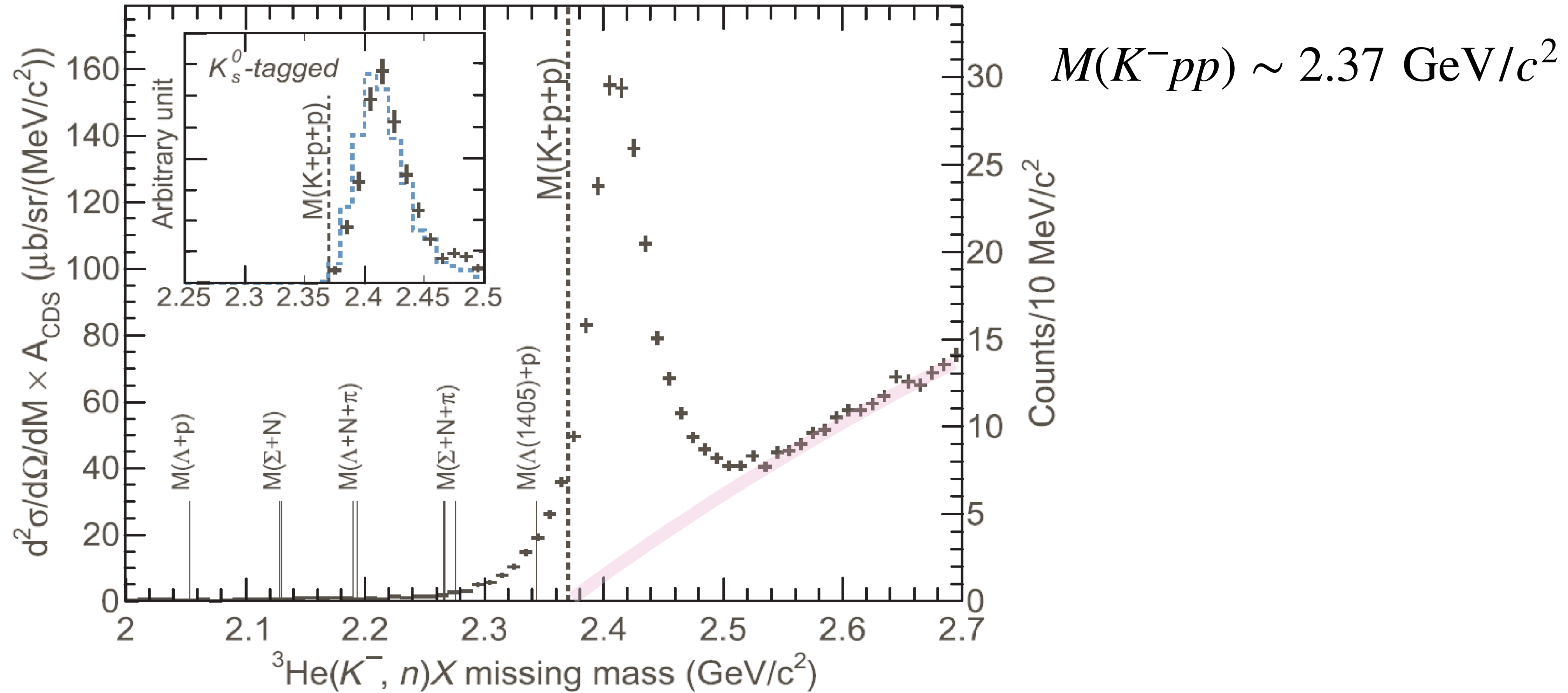
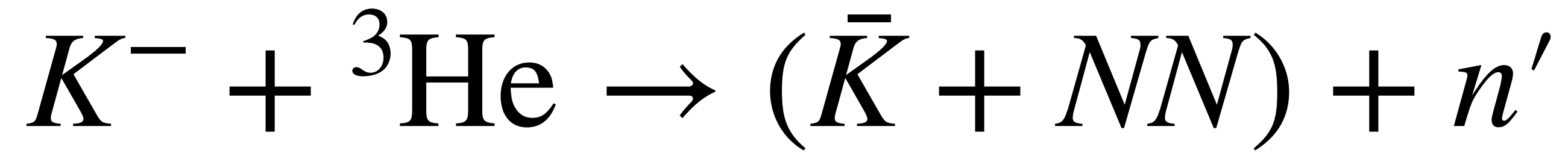

${}^3\text{He}(K^-, n_{\text{NC}})X$ – semi-inclusive

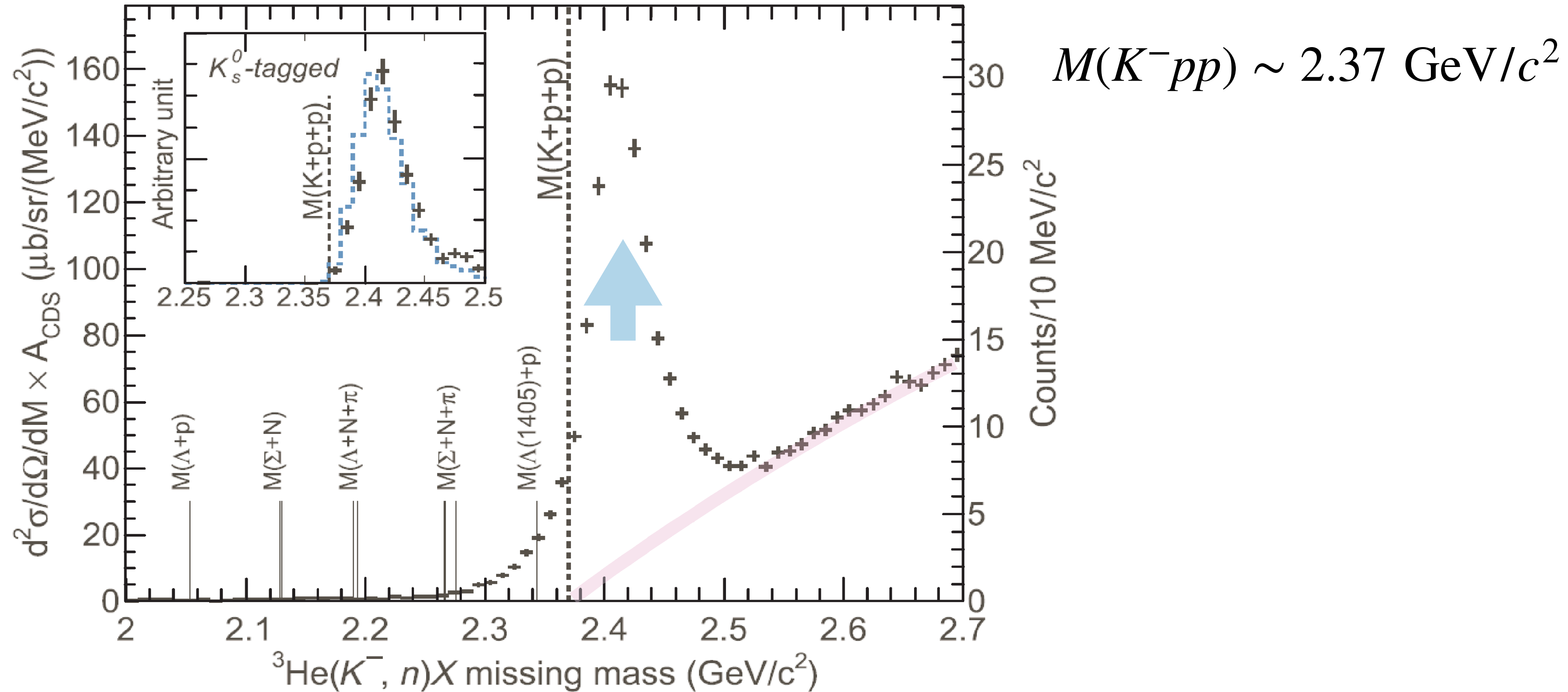
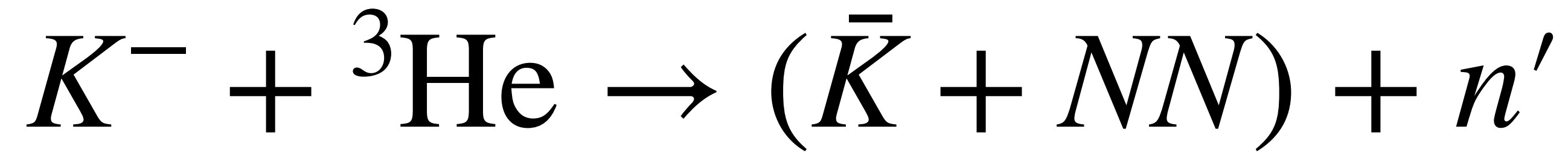

A nucleon knockout reaction $K^-N \rightarrow \bar{K}n'$ is the dominant reaction process

${}^3\text{He}(K^-, n_{\text{NC}})X$ – semi-inclusive

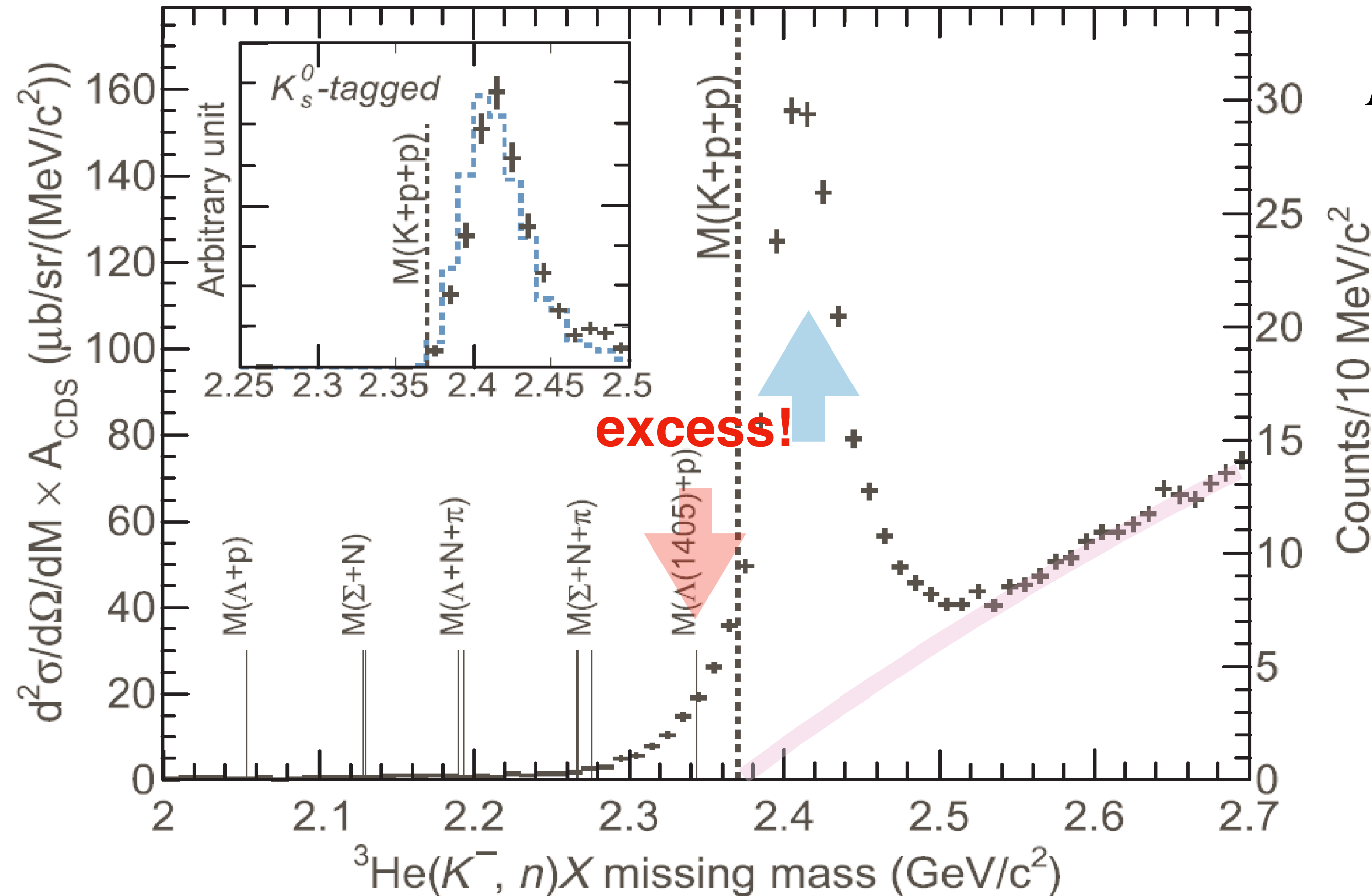
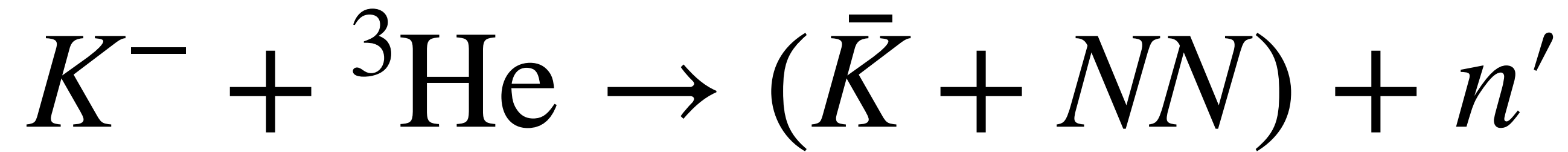

$$M(K^-pp) \sim 2.37 \text{ GeV}/c^2$$

How to study excess:
 $\bar{K} + NN \rightarrow \Lambda p$ happens
 only when all the
 particles are in the
 strong interaction range,
 because of energy-
 momentum mismatch

A nucleon knockout reaction $K^-N \rightarrow \bar{K}n'$ is the dominant reaction process

Acceptance for $K^-4\text{He}$ reaction

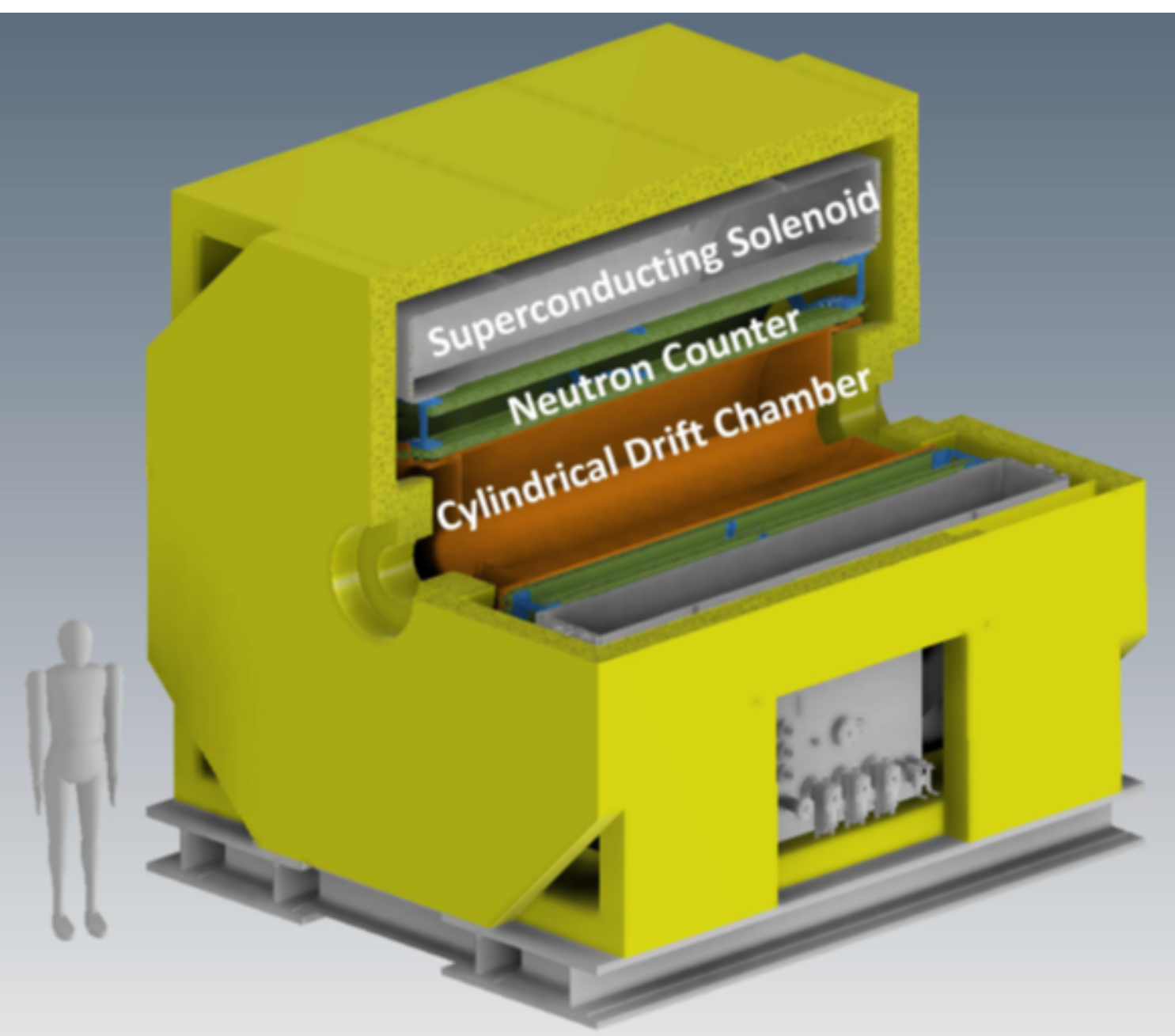
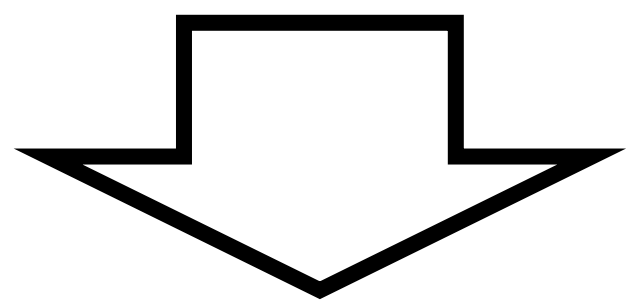
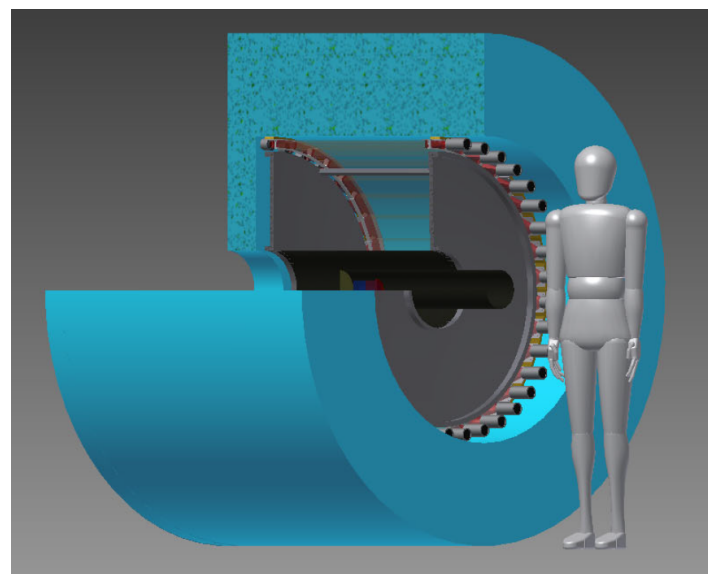

Δd in CDS

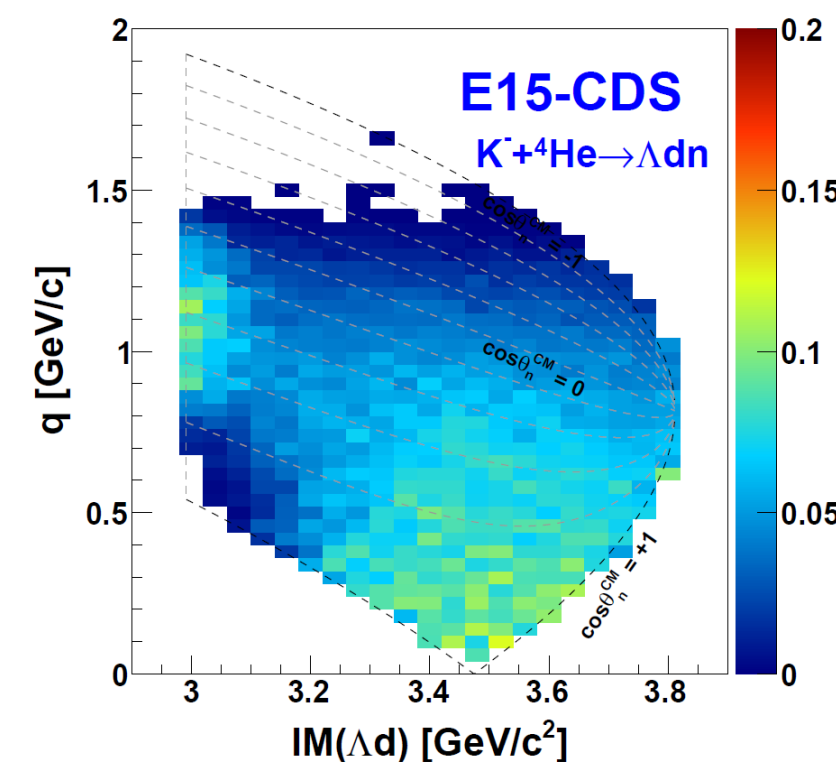

Δpn in CDS

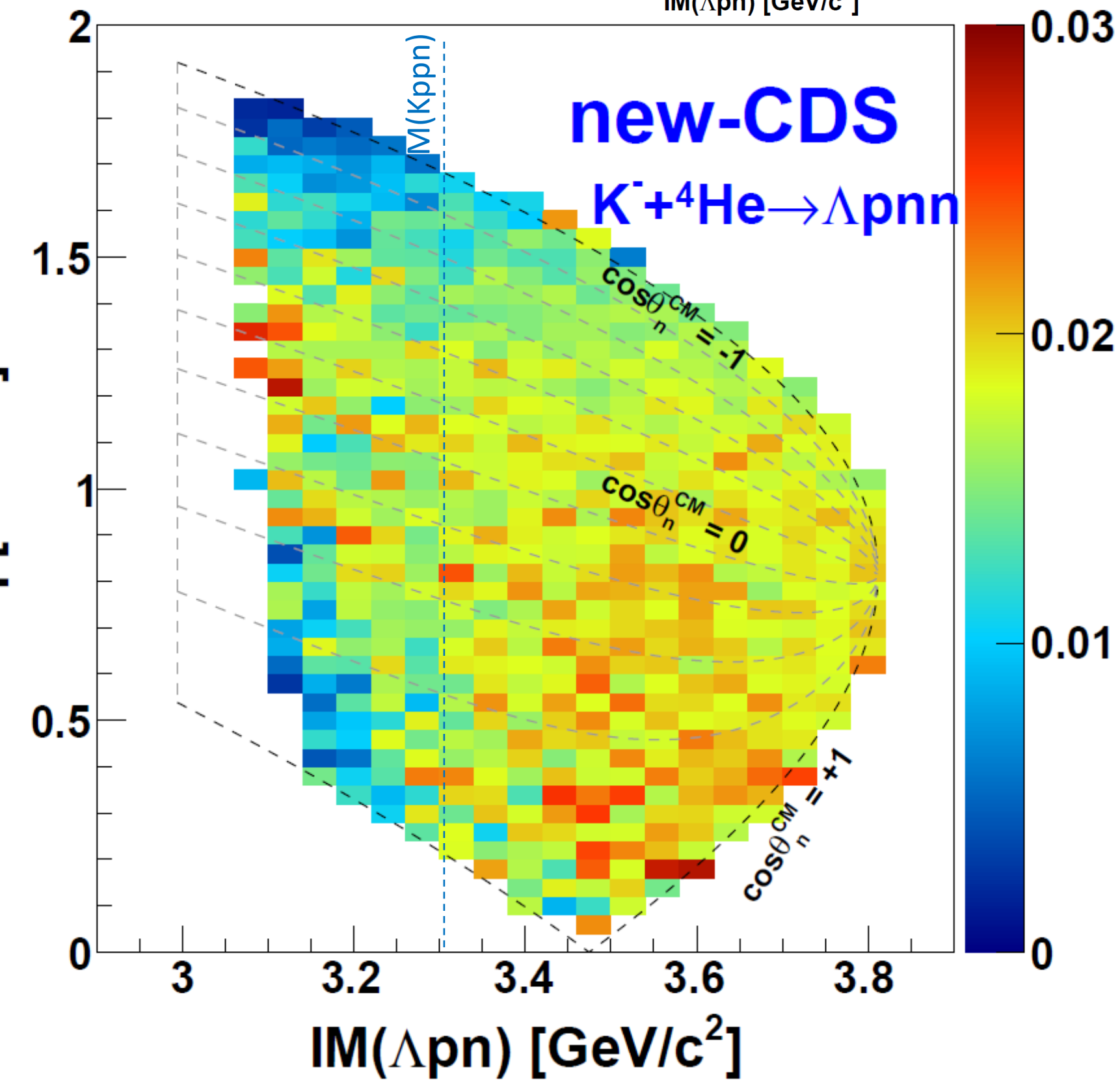
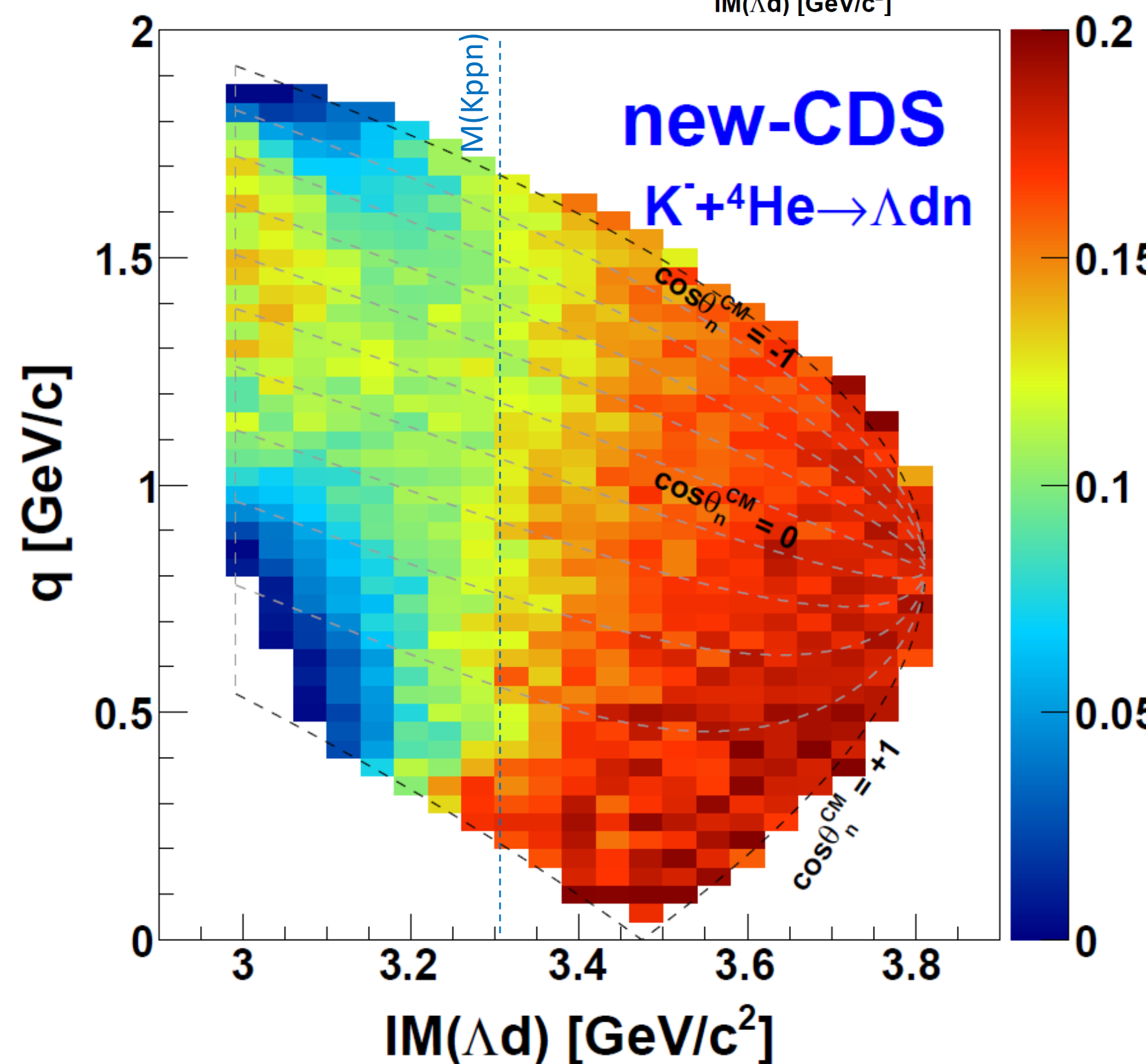
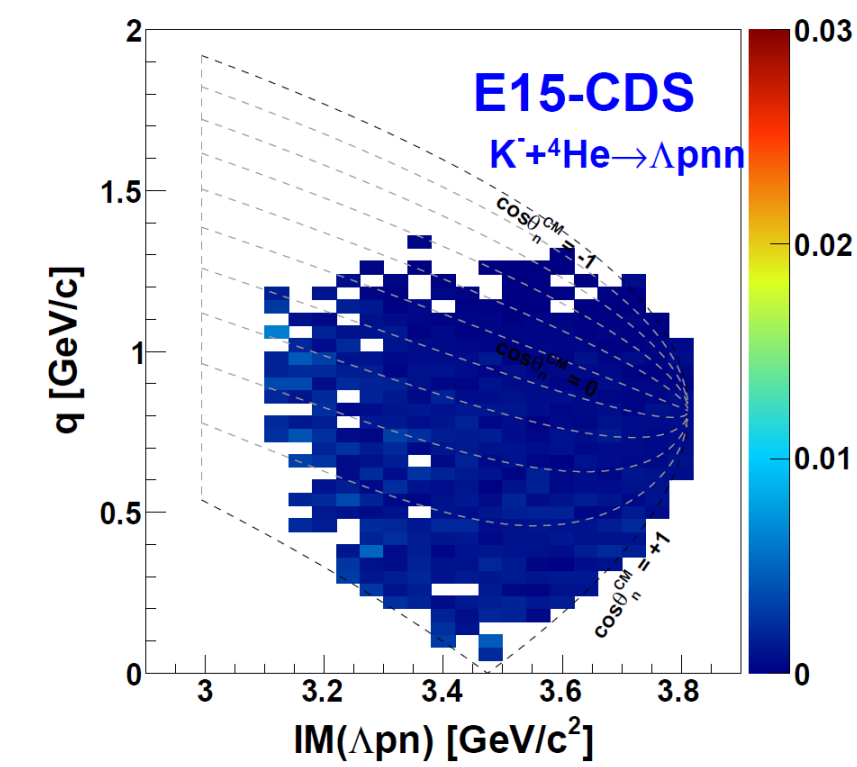

Possible $I(J^P)$?

$\bar{K}NN : J^P = 0^-, I = 1/2: I_{NN} = 1, S_{NN} = 0, L_{\bar{K}} = 0$

nucleon isospin symmetric ($I_{NN} = 1$) and spin anti-symmetric ($S_{NN} = 0$)

$\bar{K}NN : J^P = 1^-, I = 1/2: I_{NN} = 0, S_{NN} = 1, L_{\bar{K}} = 0$

nucleon isospin anti-symmetric ($I_{NN} = 0$) and spin symmetric ($S_{NN} = 1$)

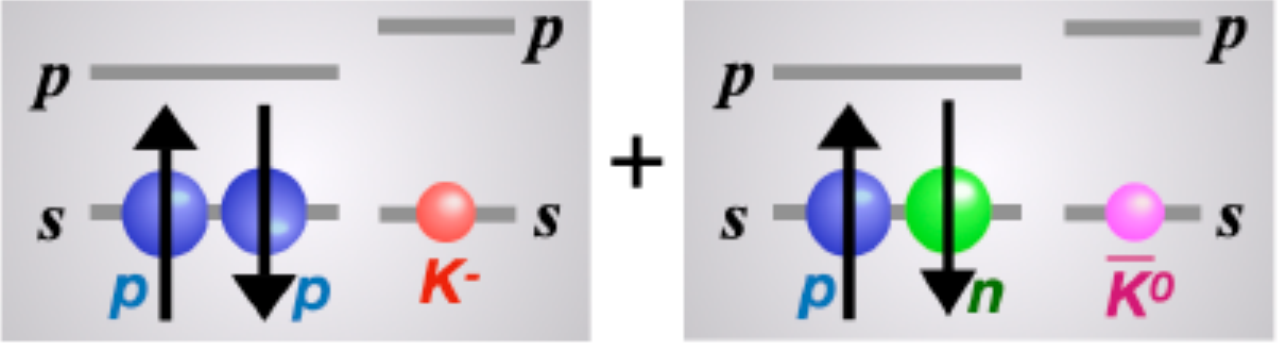
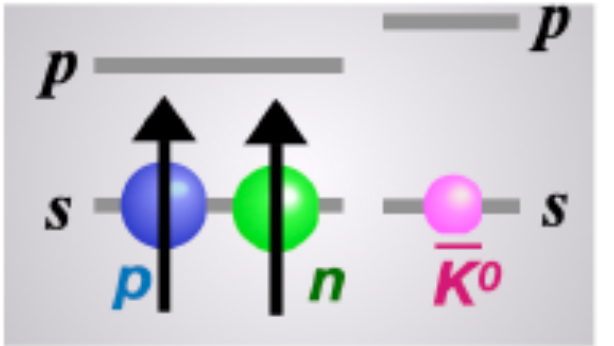
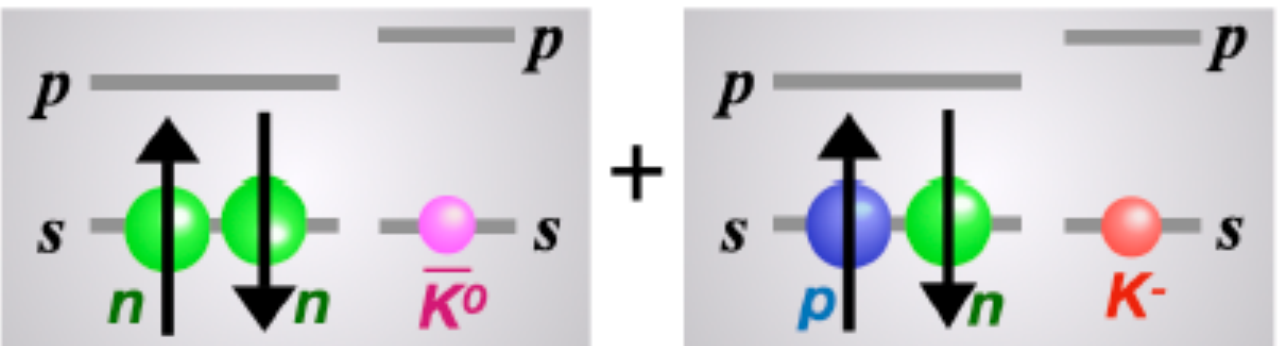
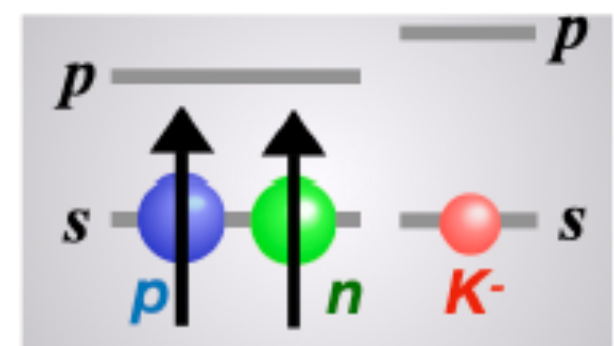
$I(\bar{K}NN) / J^P(\bar{K}NN)$	$(1/2) / (0^-)$	$(1/2) / (1^-)$
<i>NN symmetry</i>	$I(NN) = 1, S(NN) = 0$	$I(NN) = 0, S(NN) = 1$
<p>“$K^- pp$”</p> <p>$I_3(\bar{K}NN) = +\frac{1}{2}$</p>	 $-\sqrt{\frac{1}{3}} \left(\sqrt{2} K^- pp + \bar{K}^0 \frac{pn + np}{\sqrt{2}} \right) \otimes \left(\frac{\uparrow\downarrow - \downarrow\uparrow}{\sqrt{2}} \right)$	 $\bar{K}^0 \frac{(pn - np)}{\sqrt{2}} \otimes \left(\uparrow\uparrow, \frac{\uparrow\downarrow + \downarrow\uparrow}{\sqrt{2}}, \downarrow\downarrow \right)$
<p>“$\bar{K}^0 nn$”</p> <p>$I_3(\bar{K}NN) = -\frac{1}{2}$</p>	 $-\sqrt{\frac{1}{3}} \left(\sqrt{2} \bar{K}^0 nn + K^- \frac{pn + np}{\sqrt{2}} \right) \otimes \left(\frac{\uparrow\downarrow - \downarrow\uparrow}{\sqrt{2}} \right)$	 $-K^- \frac{(pn - np)}{\sqrt{2}} \otimes \left(\uparrow\uparrow, \frac{\uparrow\downarrow + \downarrow\uparrow}{\sqrt{2}}, \downarrow\downarrow \right)$
<i>$\bar{K}N$ coupling</i>	$\frac{ I_{\bar{K}N} = 0 ^2}{ I_{\bar{K}N} = 1 ^2} = \frac{3}{1}$	$\frac{ I_{\bar{K}N} = 0 ^2}{ I_{\bar{K}N} = 1 ^2} = \frac{1}{3}$
$\frac{\sigma_{\bar{K}^0 nn}}{\sigma_{K^- pp}}$	$0.13 \sim 0.15$	~ 0.75

“ $K^- pp$ ” $\rightarrow \Lambda p$ requires $I = 1/2$, presence of kaon requires negative parity, and the Λp decay must be in P-wave due to the negative parity

Λp decay axis and spin axis of $\bar{K}NN$ J^P

spin axis distribution referring to the decay axis

$\bar{K}NN : J^P = 0^-, I = 1/2: I_{NN} = 1, S_{NN} = 0, L_{\bar{K}} = 0$

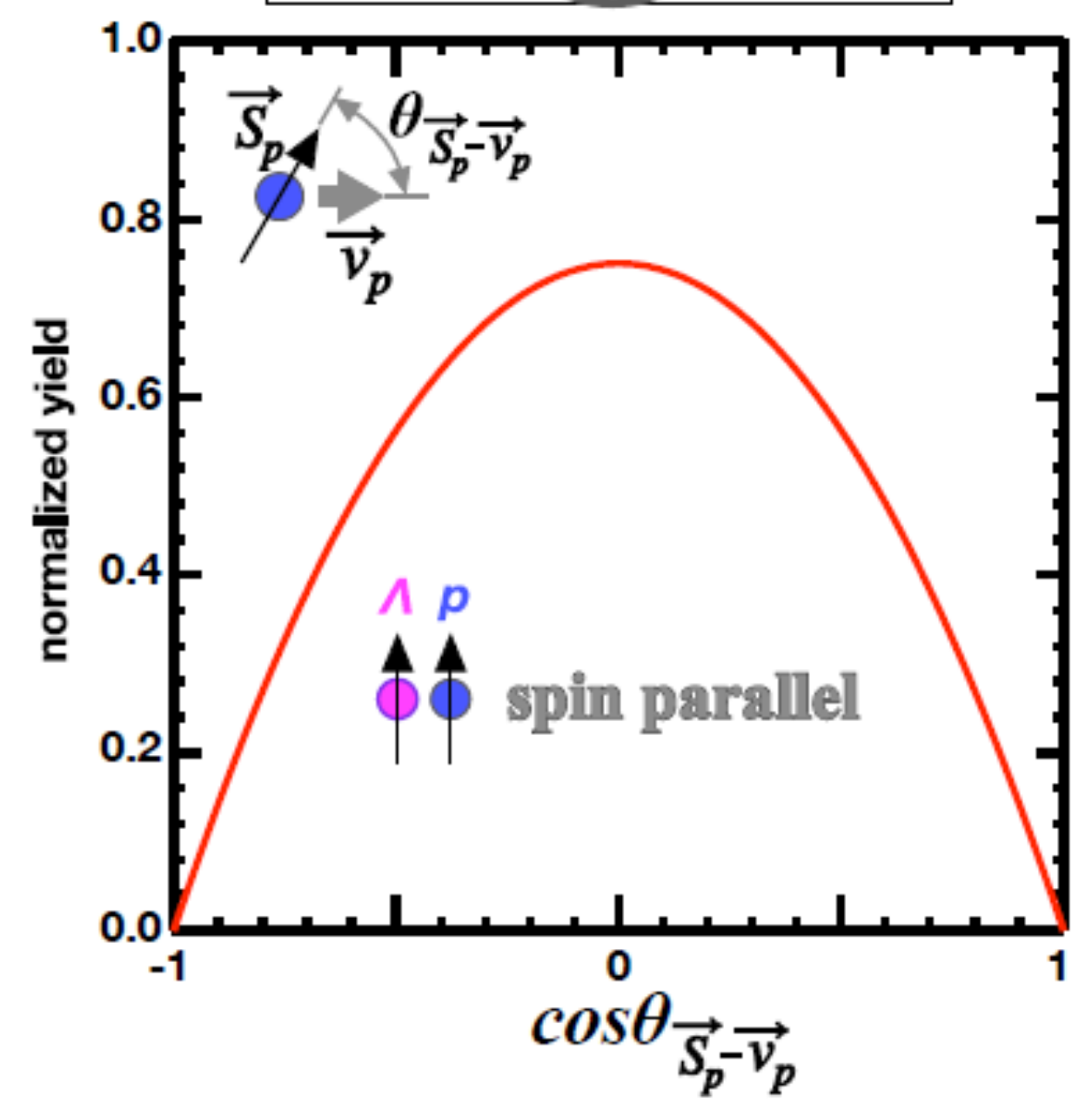
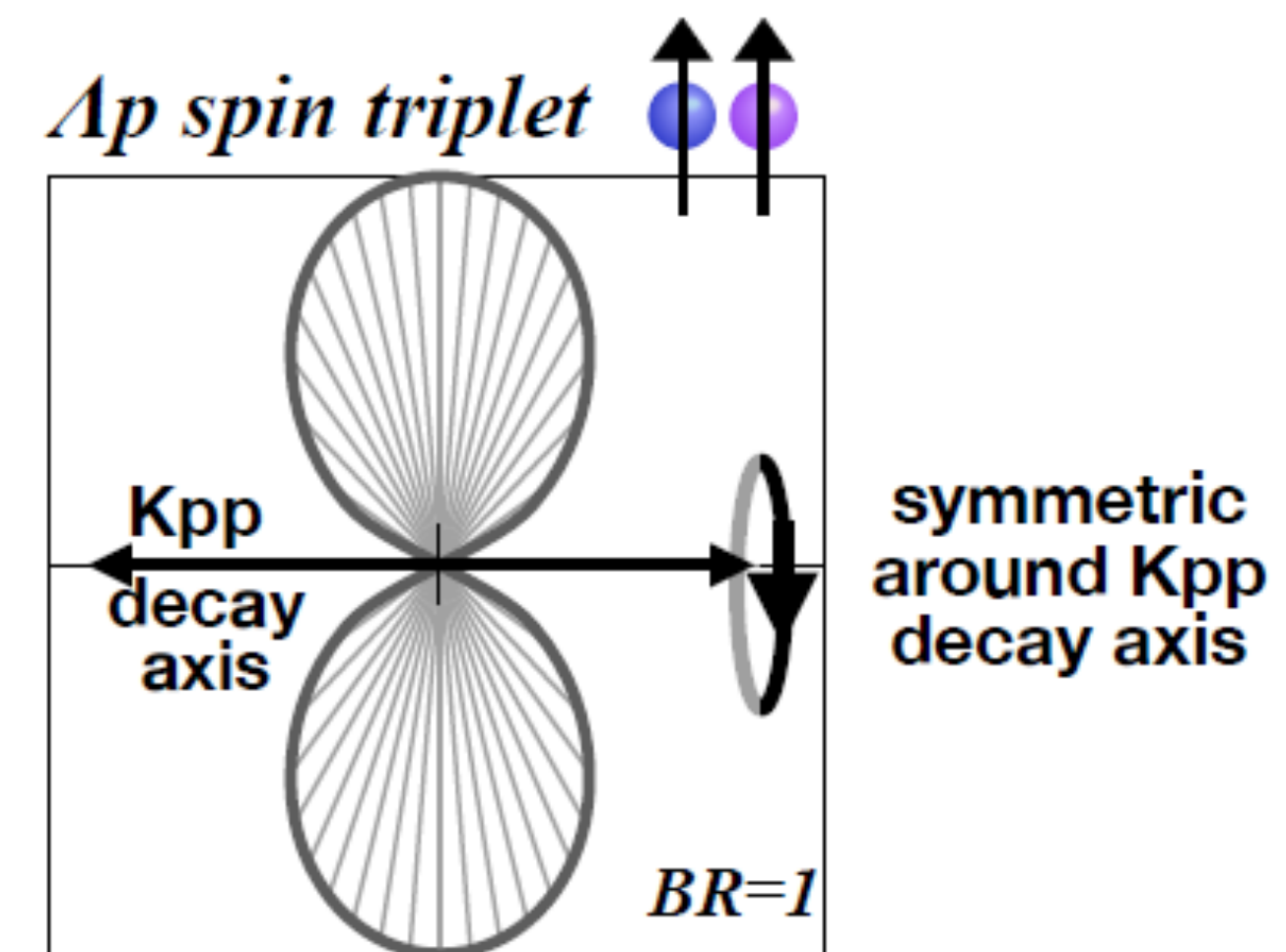

$\bar{K}NN : J^P = 1^-, I = 1/2: I_{NN} = 0, S_{NN} = 1, L_{\bar{K}} = 0$

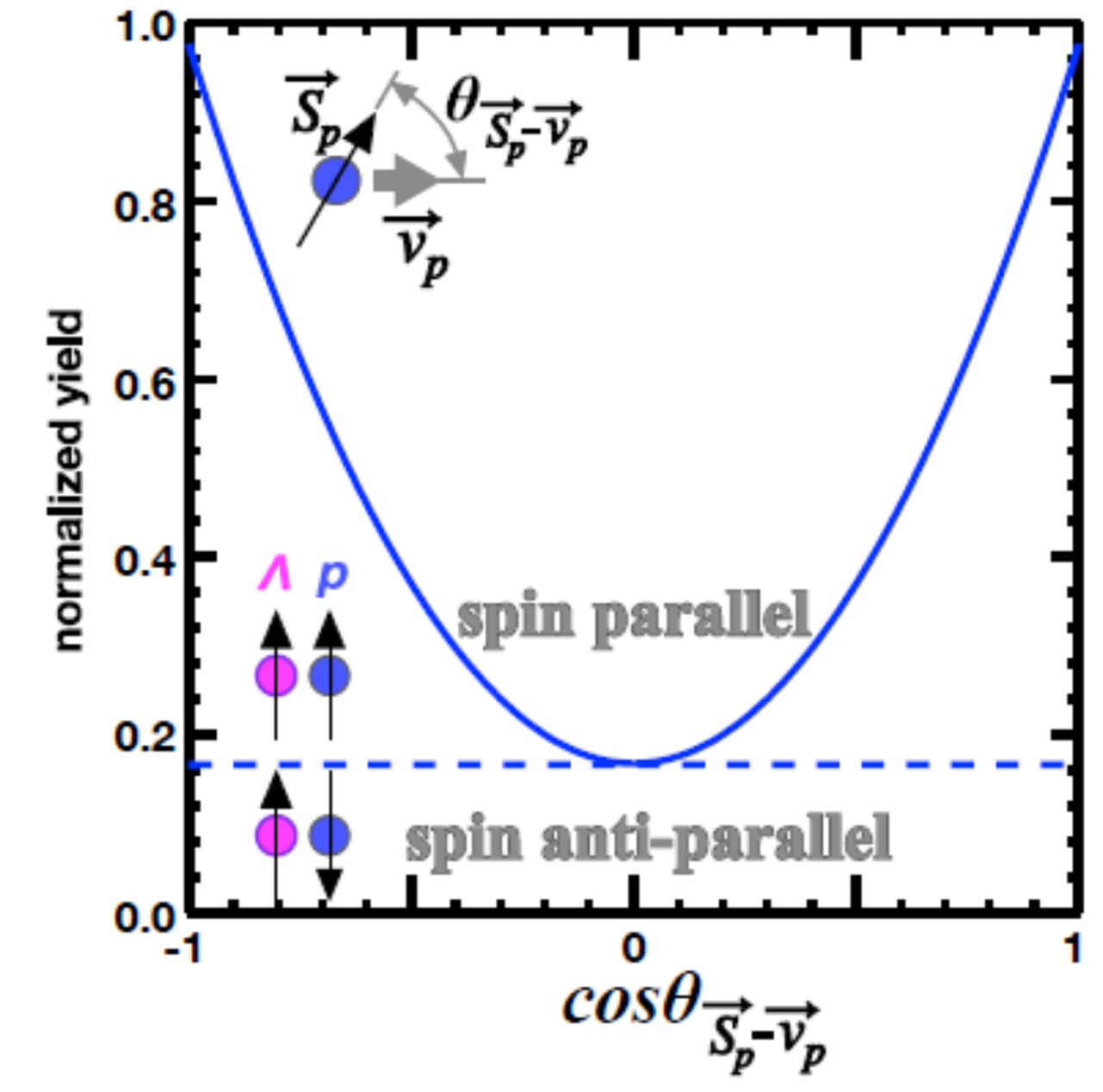
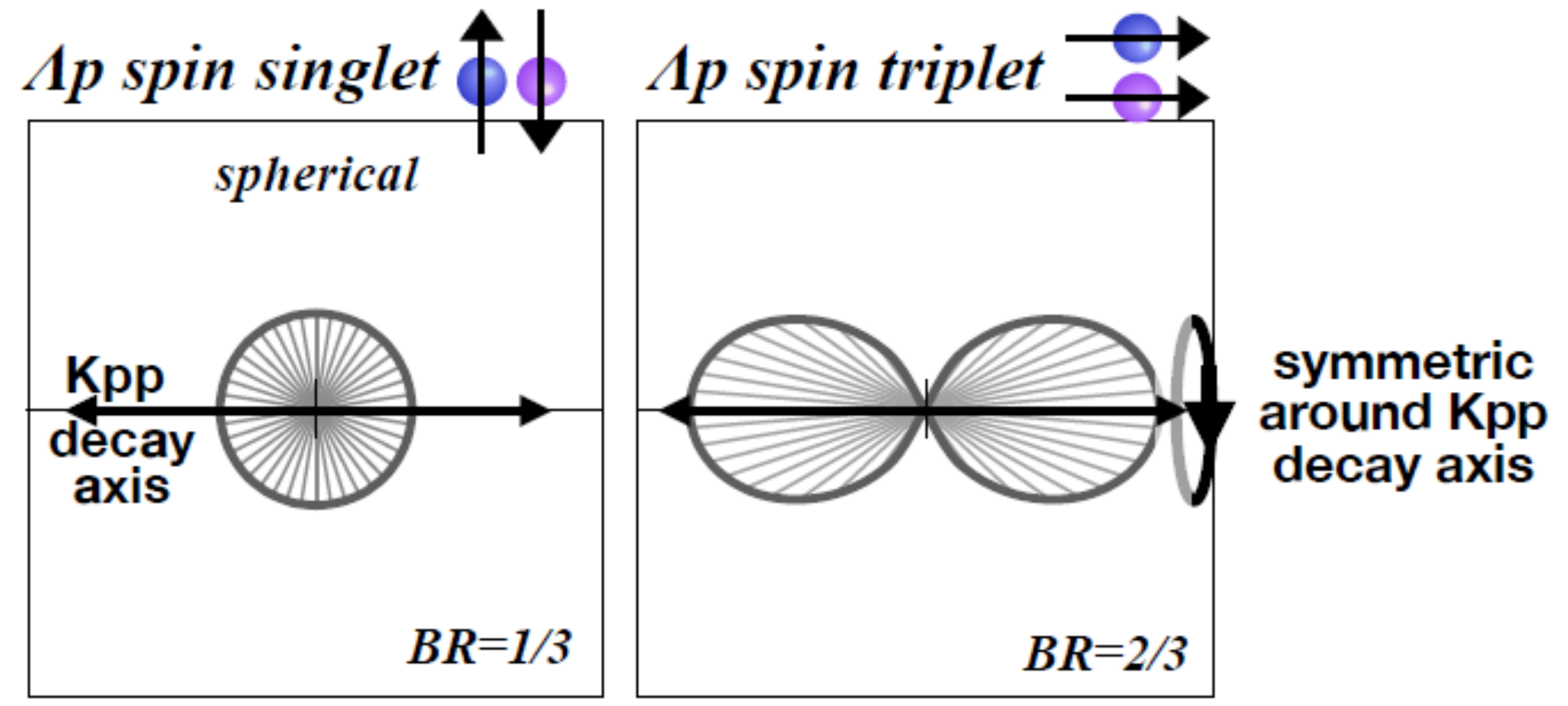

How to measure spin-spin correlation

– spin asymmetry measurement using $\Lambda \rightarrow p\pi^-$ & p-C(H) scattering–

p-C(H) scattering sensitive only on ϕ asymmetry

$$\vec{S}_{\Lambda}^{o(\Lambda \rightarrow p\pi^-)} \approx \vec{v}_p^{(\Lambda \rightarrow p\pi^-)} \text{ (in } \Lambda\text{-CM)}$$

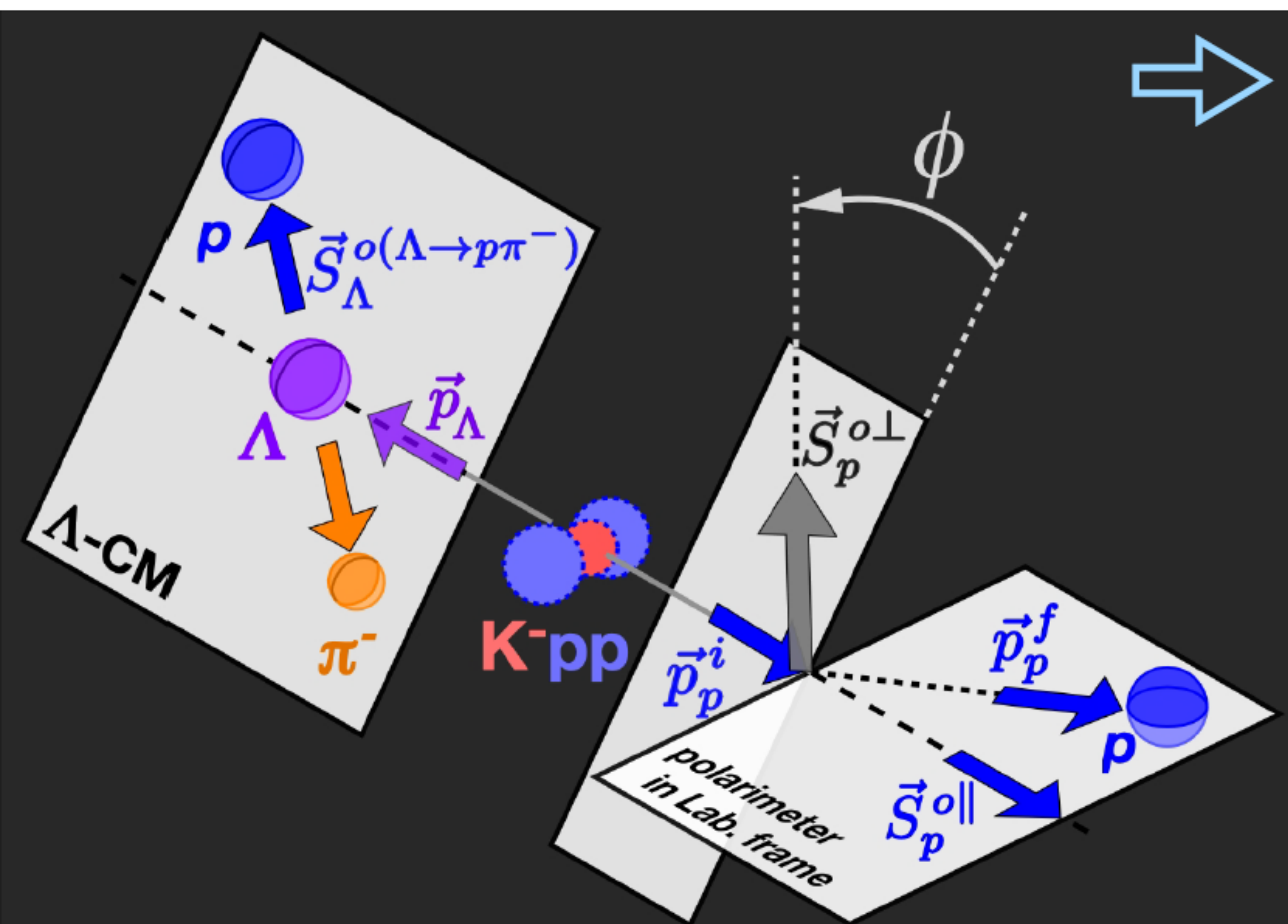

$$N(\phi) d\phi \propto (1 + r \cdot \alpha_{\Lambda p} \cos \phi) d\phi$$

r : scaling factor

$$r = A_{\Lambda} \cdot A_{pC} \cdot \vec{S} \cdot \vec{S}^{\parallel} \cdot c_{conv}$$

A_{Λ} : Λ asymmetry parameter

A_{pC} : proton spin-analyzing-power
on carbon (and on p)

$\vec{S} \cdot \vec{S}^{\parallel}$ ($\equiv \vec{S}_p \cdot \vec{S}_p^{\parallel}$) : spin sensitivity
referring to motional axis

c_{conv} : convolution coefficient
between two asymmetries

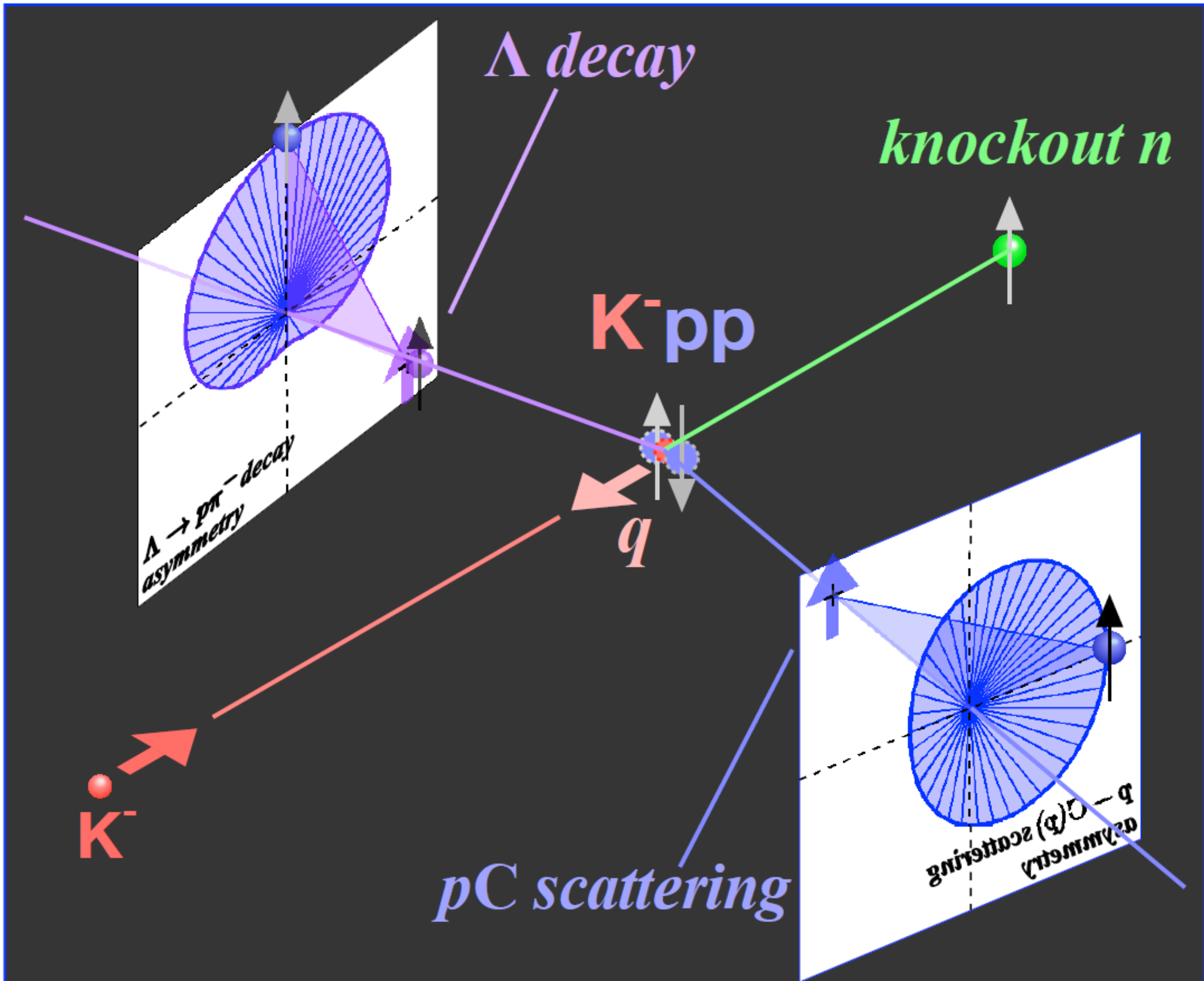

Λp spin-spin asymmetry

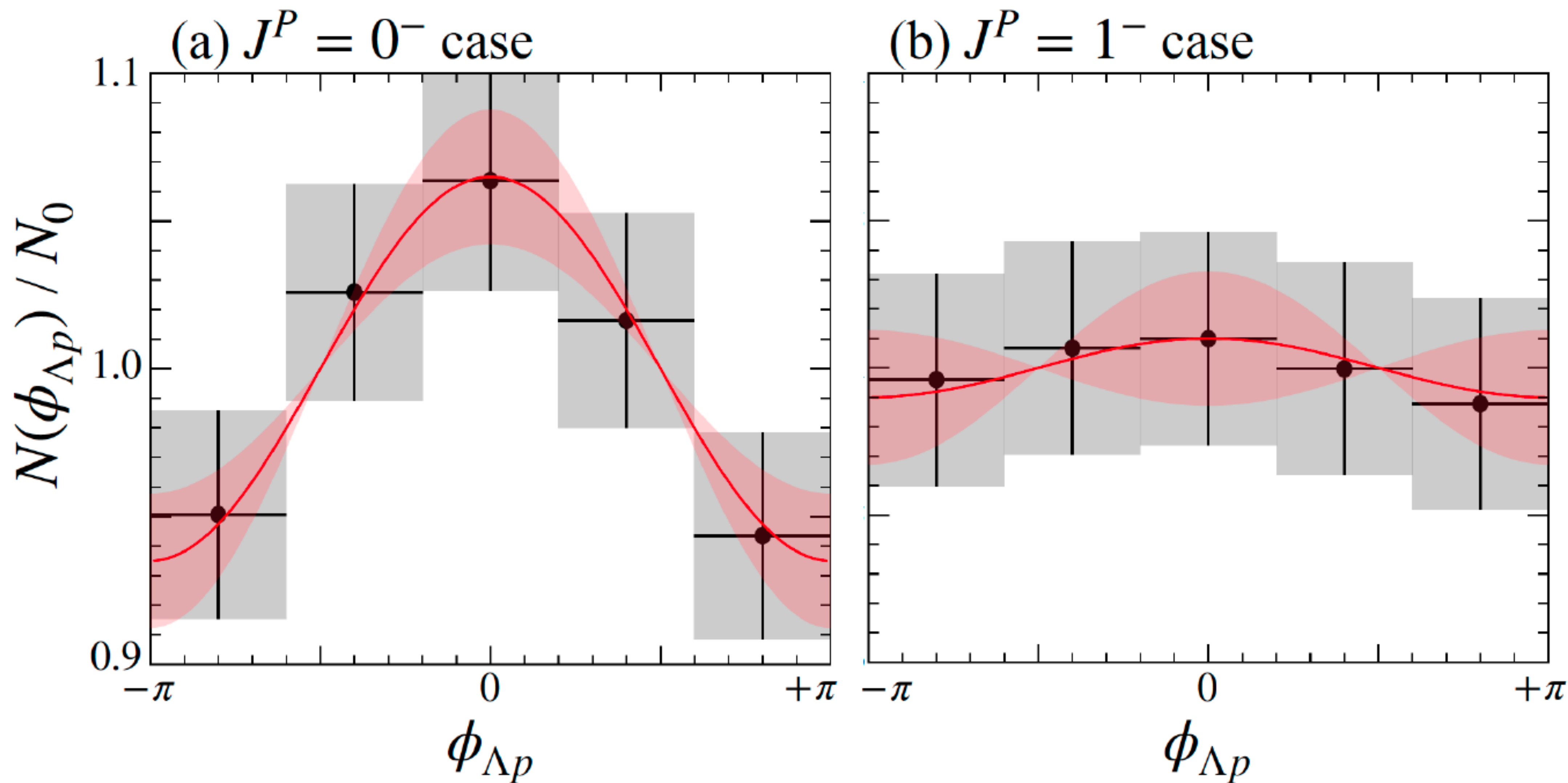

New Spectrometer under construction

Preparation of planned devices / detectors



Return Yoke



Super-conducting Solenoid Coil

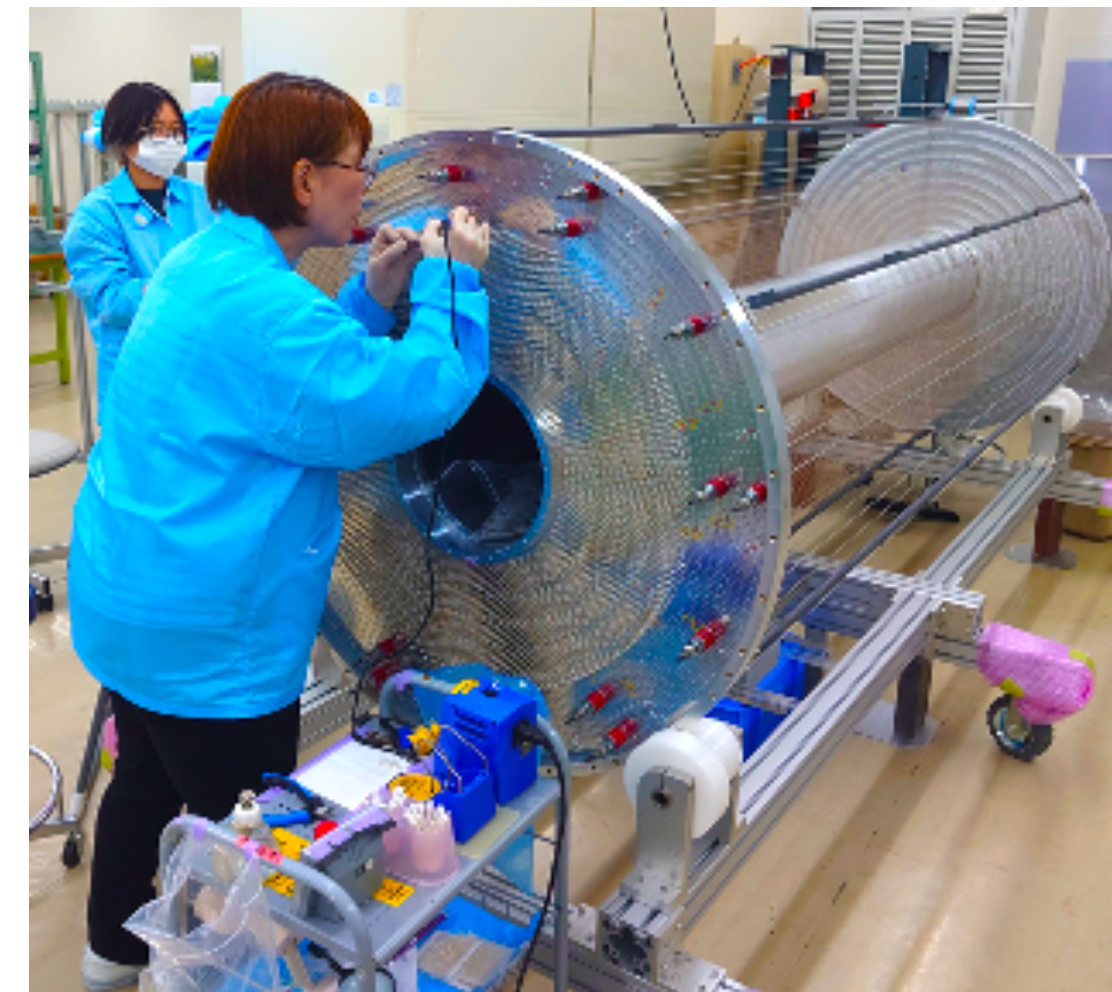

under construction

Cylindrical Drift Chamber (CDC)

New Spectrometer under construction

Preparation of planned devices / detectors



Return Yoke



Super-conducting Solenoid Coil

under construction

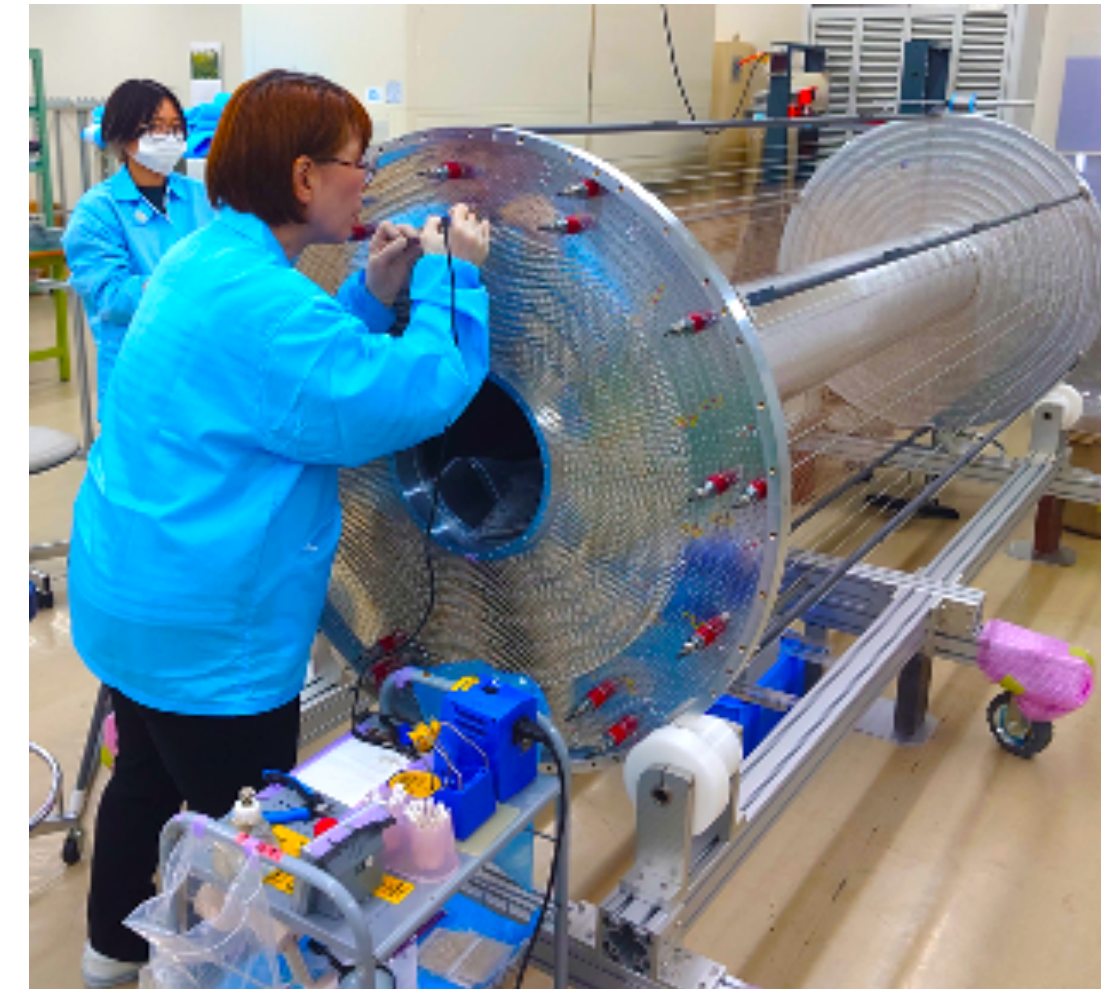

Cylindrical Drift Chamber (CDC)

Additional detectors to improve

To detect the proton in Fermi-motion
& to drastically improve vertex resolution (Λ/Σ^0 separation)

Vertex Fiber Tracker (VFT)



Constructed by T.Hashimoto

**doble layer
@ crossing
angle $\pm 45^\circ$**

Vertex Straw-tube Tracker
(VST)

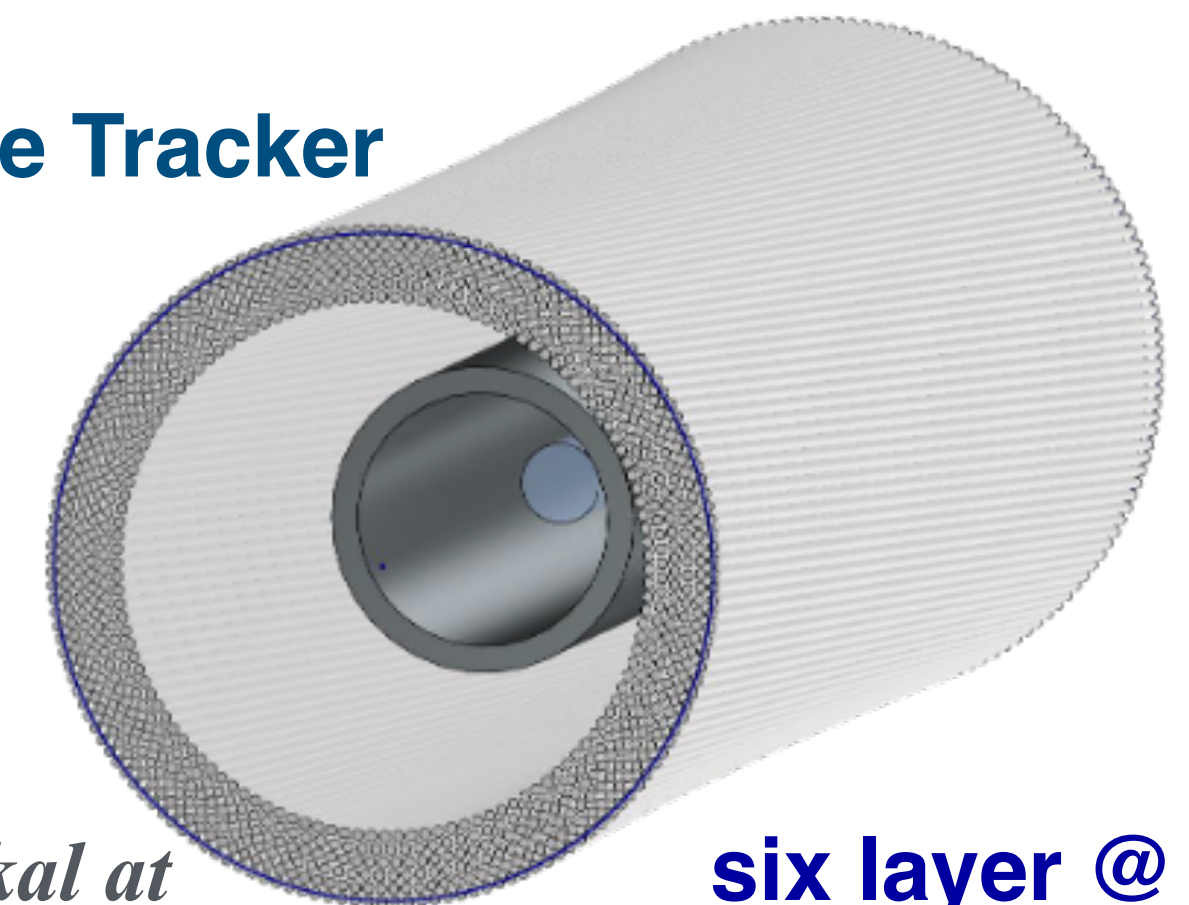

*Currently, J. Zmeskal at
SMI is applying for funding.*

**six layer @
crossing angle $\pm 6^\circ$**

Superconducting Solenoid Magnet

SHI FA-50
(air cooling) RDE-418D4 ³⁶



being constructed in cooperation with the J-PARC Cryogenics Section

- Same design as “the detector solenoid magnet” for COMET-I

- 3.3m x 3.3m x 3.9m, ~108t in total
- Max. field of 1.0T @ center
 - 189A – 10V
- NbTi/Cu SC wire, 98km in total
- **Conduction-cooling with GM*3**
- Semi-active quench-back system
- **Will be completed in FY2024**

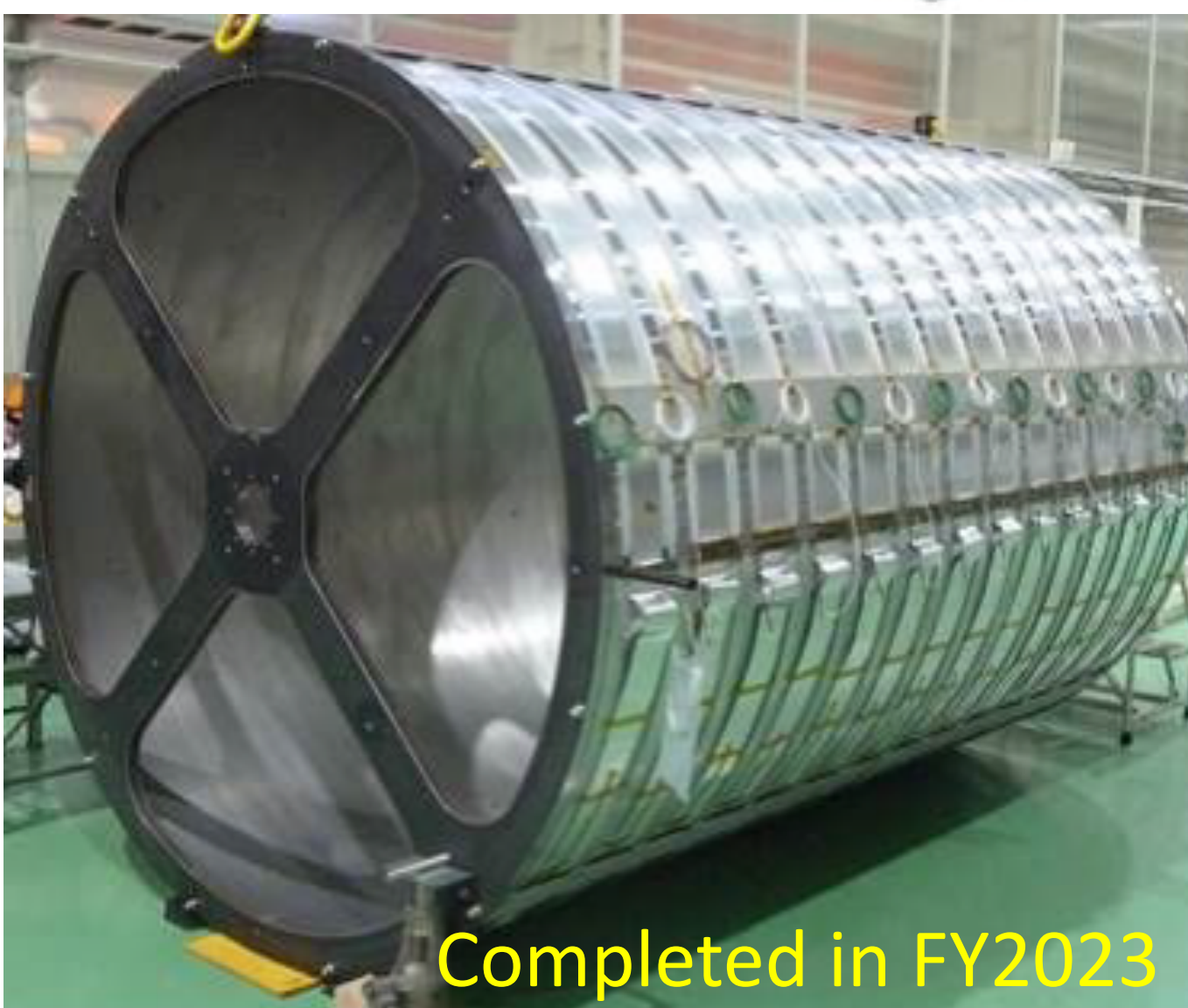

Cylindrical Drift Chamber (CDC)

- 3 times the length of the existing CDC
 - Gas: Ar/CO₂=90/10
- The same design of the present end-cap
- Readout systems are reused

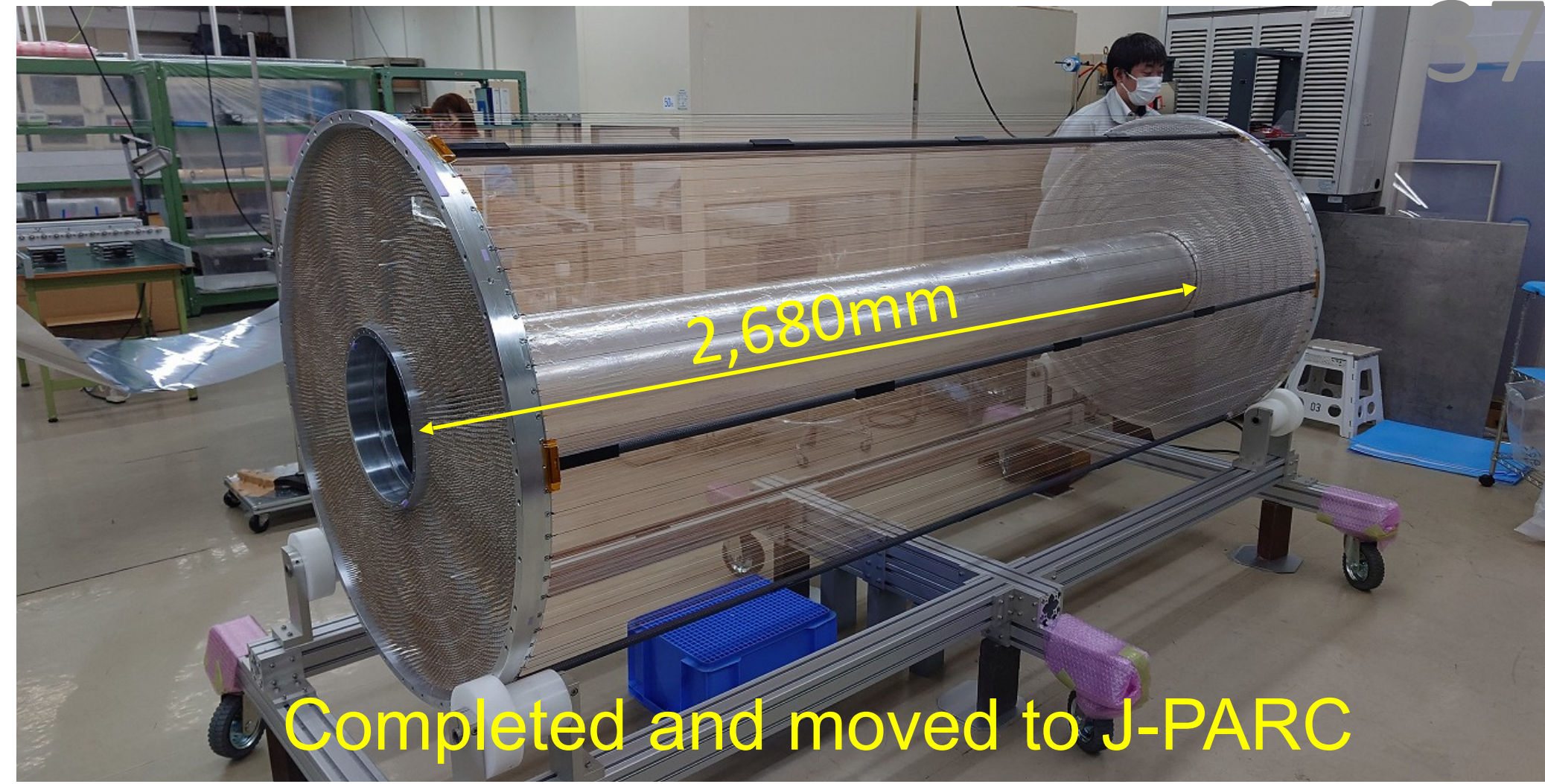

Completed this month, and commissioning will soon start @ J-PARC

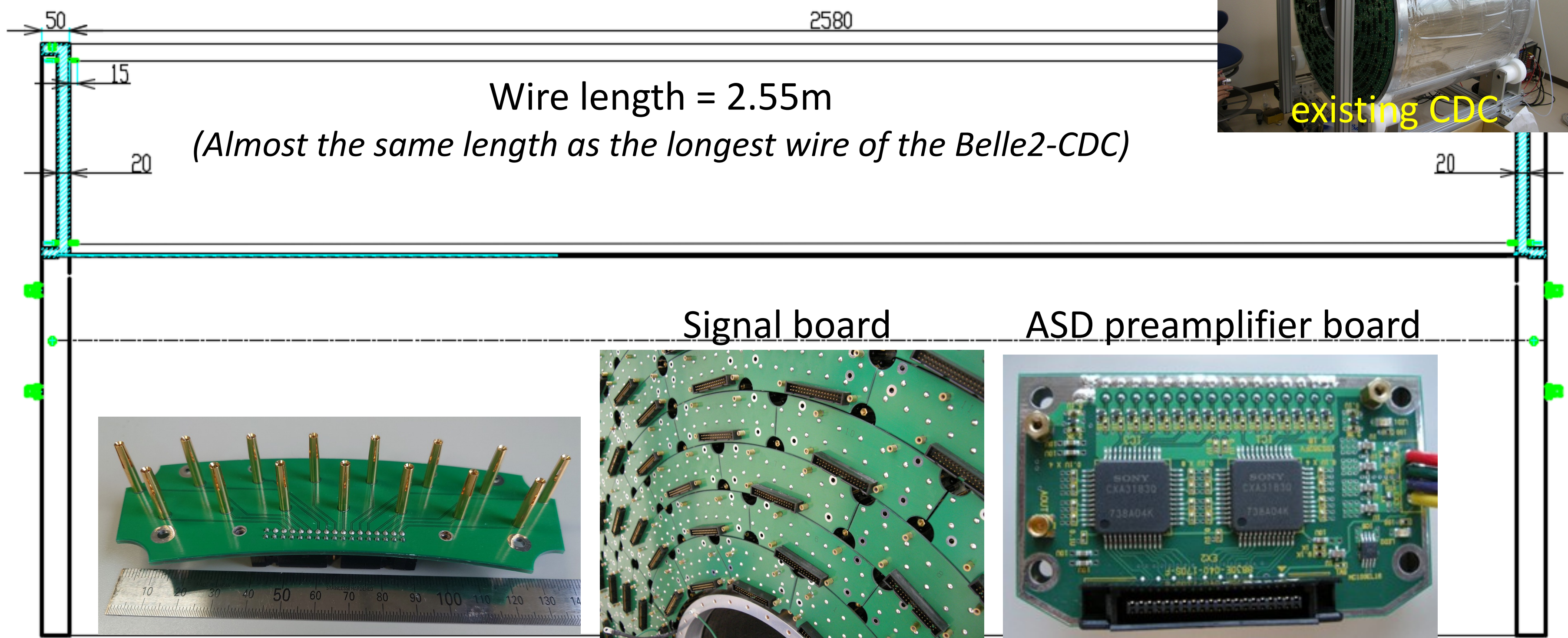
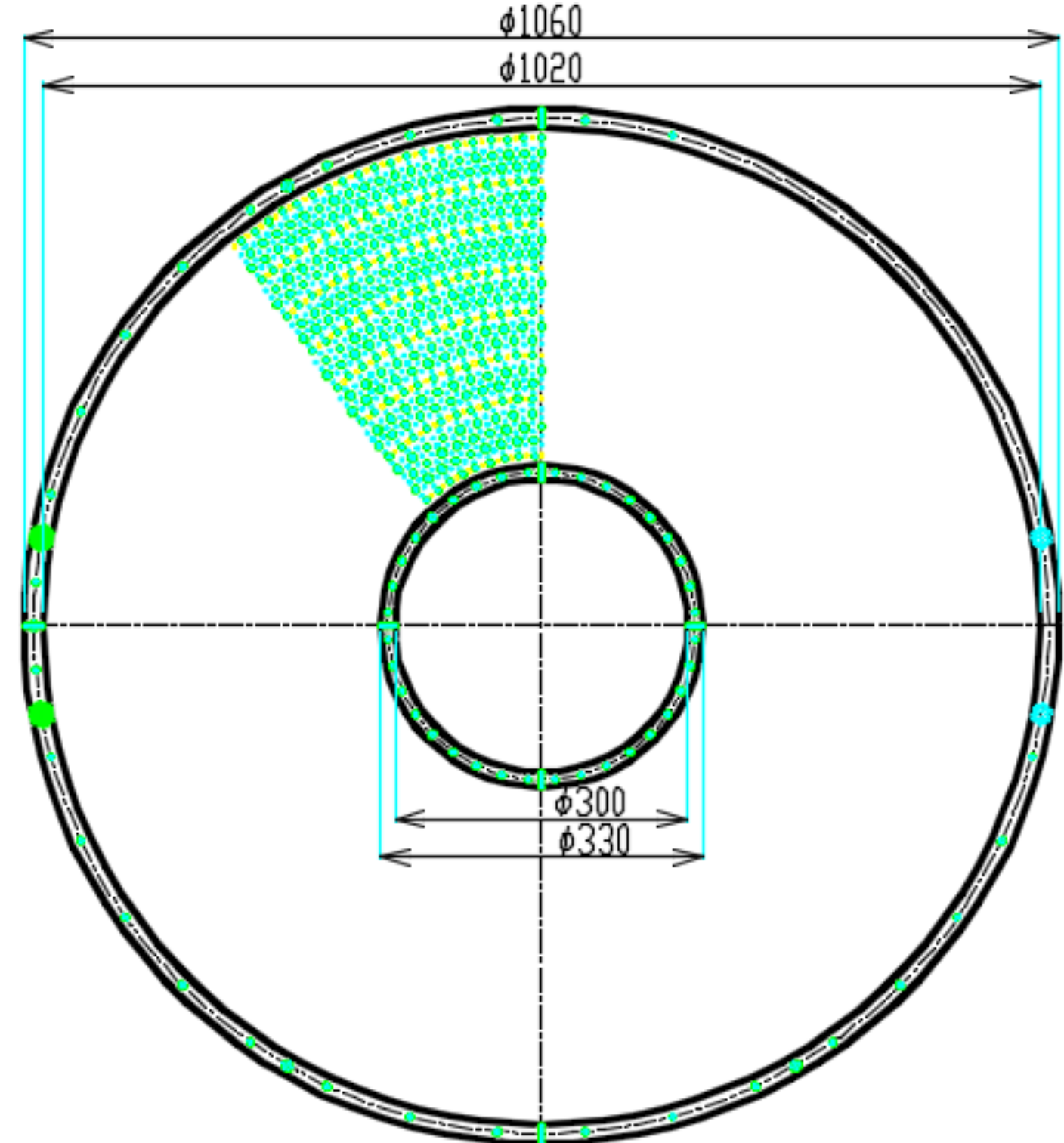
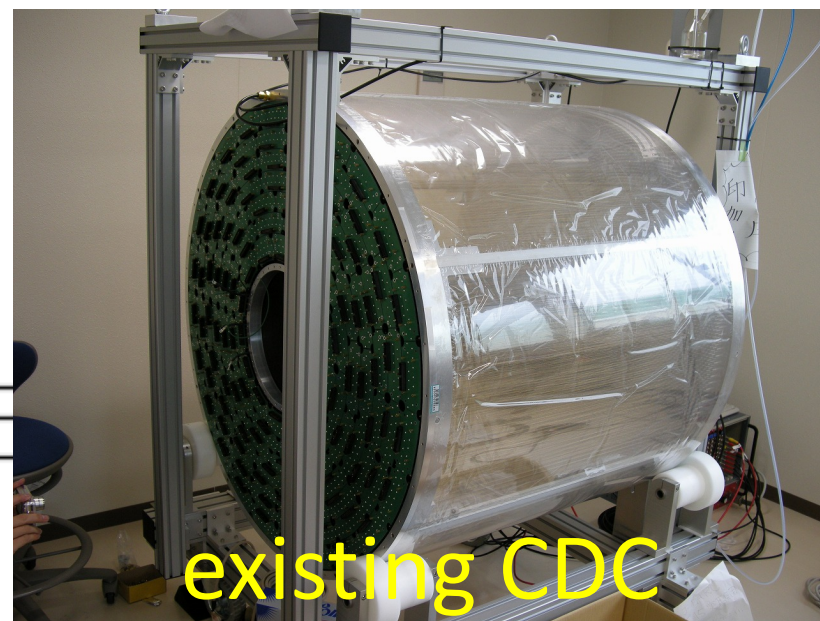

Signal board

ASD preamplifier board

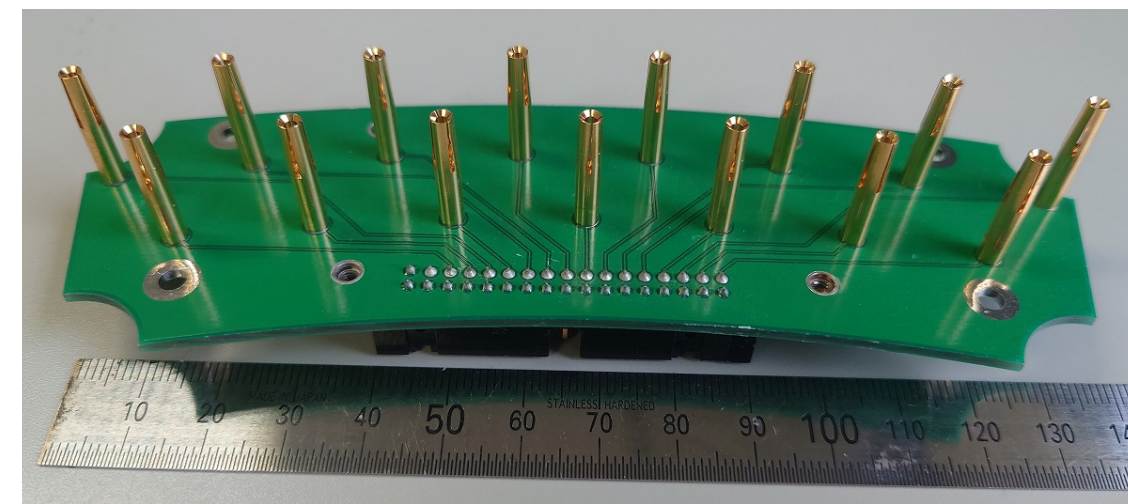

Cylindrical Neutron Counter (CNC)

- scintillator array: 2 layers, 12cm thickness
- Neutron detection efficiency of 12~36%
- 56+80=136 modules
 - ELJEN EJ-200: (T)60mm, (W)60mm, (L)3,000mm
- 1.5-inch FM-PMT [H8409(R7761)]
& MPPC array [S13361-6050AE-04]
- **Will be completed in FY2025**

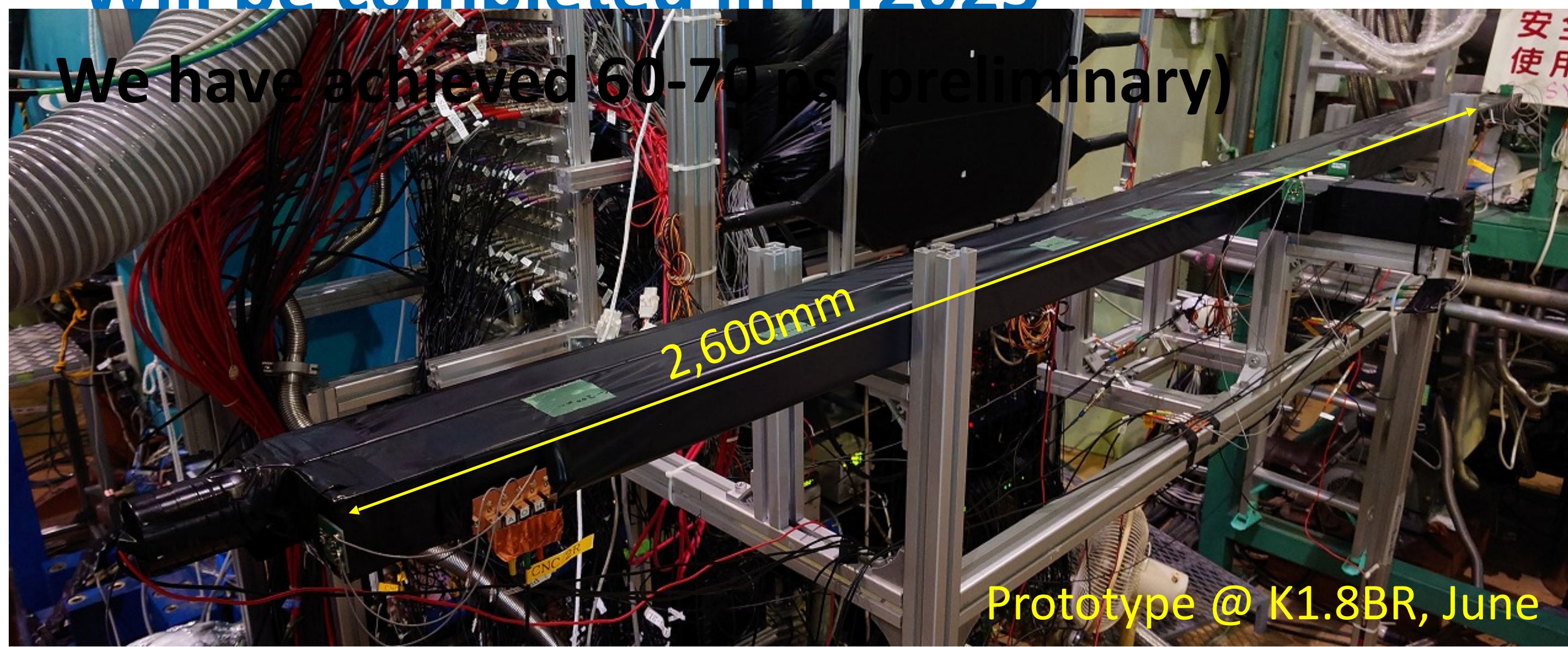
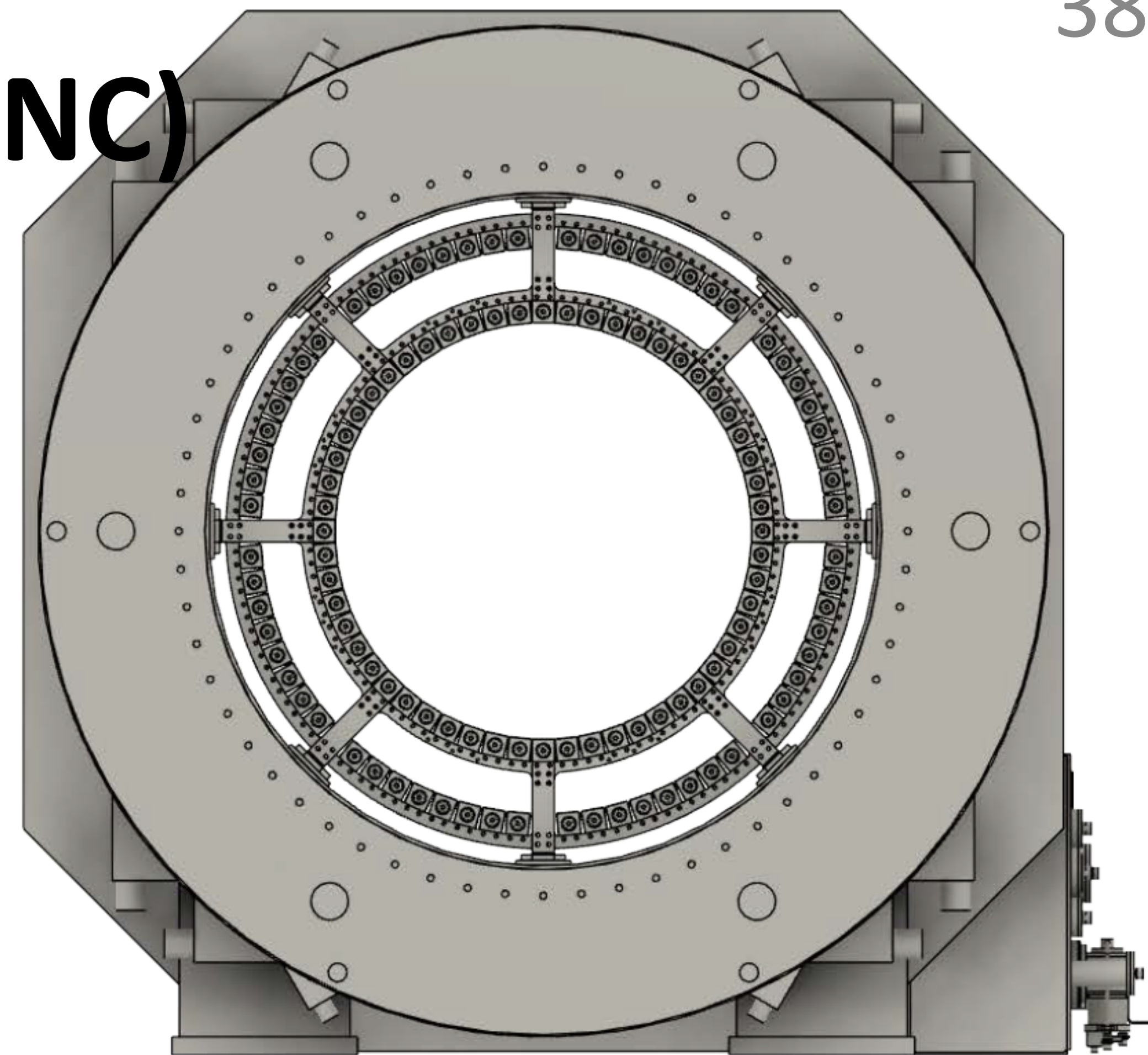

136 scintillators in total

- 56 segments @ r548~608mm
 - 112 FM-PMTs
- 80 segments @ r780~840mm
 - 160 MPPC-arrays

Support Structure

- CNC is supported at upstream, downstream and middle position
 1. pillars are mounted on the inner cylinder of the magnet
 2. ring structures are installed on the pillars
 3. each module is mounted on the ring structures
- CDC is installed by inserting a long frame bar into the center of the CDC and magnet

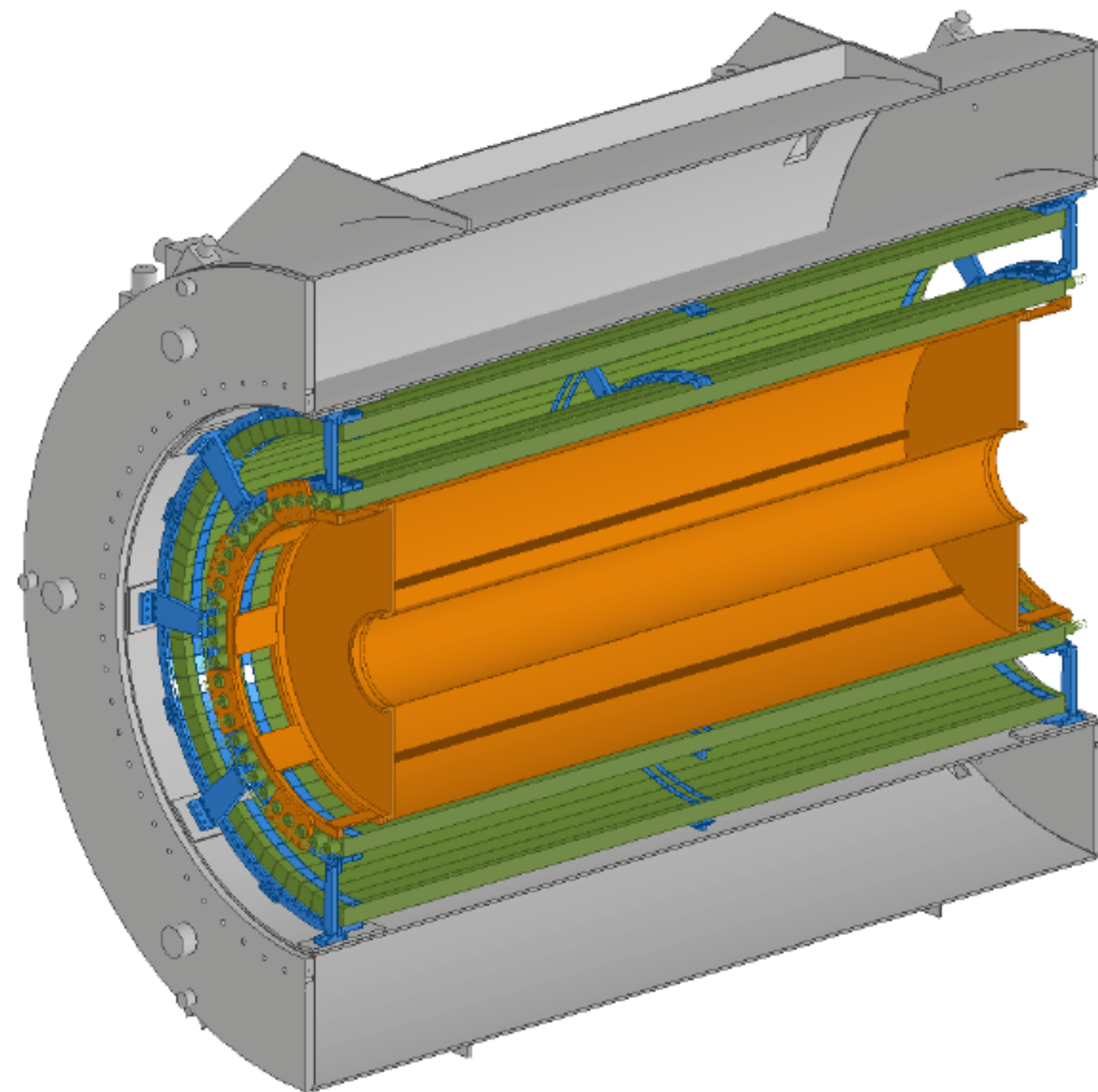
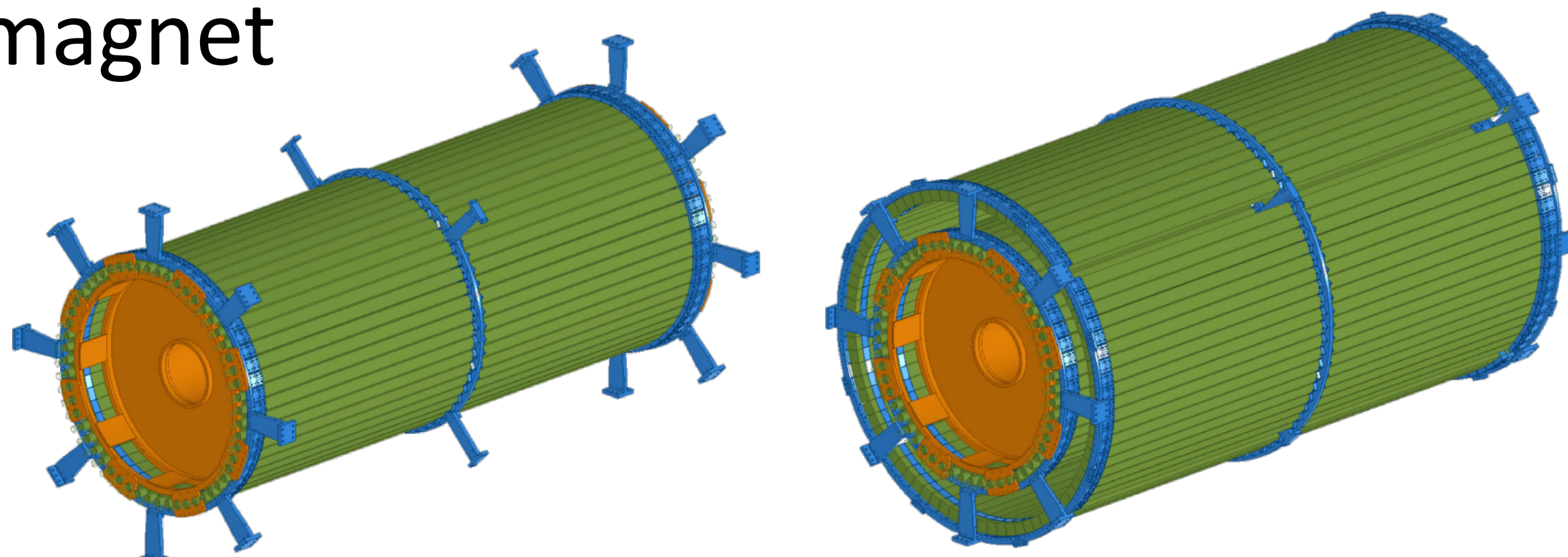

Will be prepared in FY2025-26

Summary of Experimental Status

Negative results

AMADEUS@DAΦNE

$^{12}\text{C}(\text{K}^-_{\text{stopped}}, \Lambda\text{p})$ EPJC79(2019)190

HADES@GSI

$\text{p} + \text{p} \rightarrow (\Lambda + \text{p}) + \text{K}^+$ @ 3.5 GeV

PLB742(2015)242

LEPS@SPring-8

$\text{d}(\gamma, \pi^-\text{K}^+)\text{X}$ @ 1.5-2.4 GeV

PLB728(2014)616

Positive results

FINUDA@DAΦNE

PRL94(2005)212303

$^6\text{Li}/^7\text{Li}/^{12}\text{C}(\text{K}^-_{\text{stopped}}, \Lambda\text{p})$

Multi-NA processes?

DISTO@SATURNE

PRL104(2010)132502

$\text{p} + \text{p} \rightarrow (\Lambda + \text{p}) + \text{K}^+$ @ 2.85 GeV

Intermediate $\text{N}^* \rightarrow \Lambda\text{K}^+$?

E27@J-PARC

PTEP(2015)021D01.

$\text{d}(\pi^+, \text{K}^+)\Sigma^0\text{p}$ @ 1.69 GeV/c

Need more data

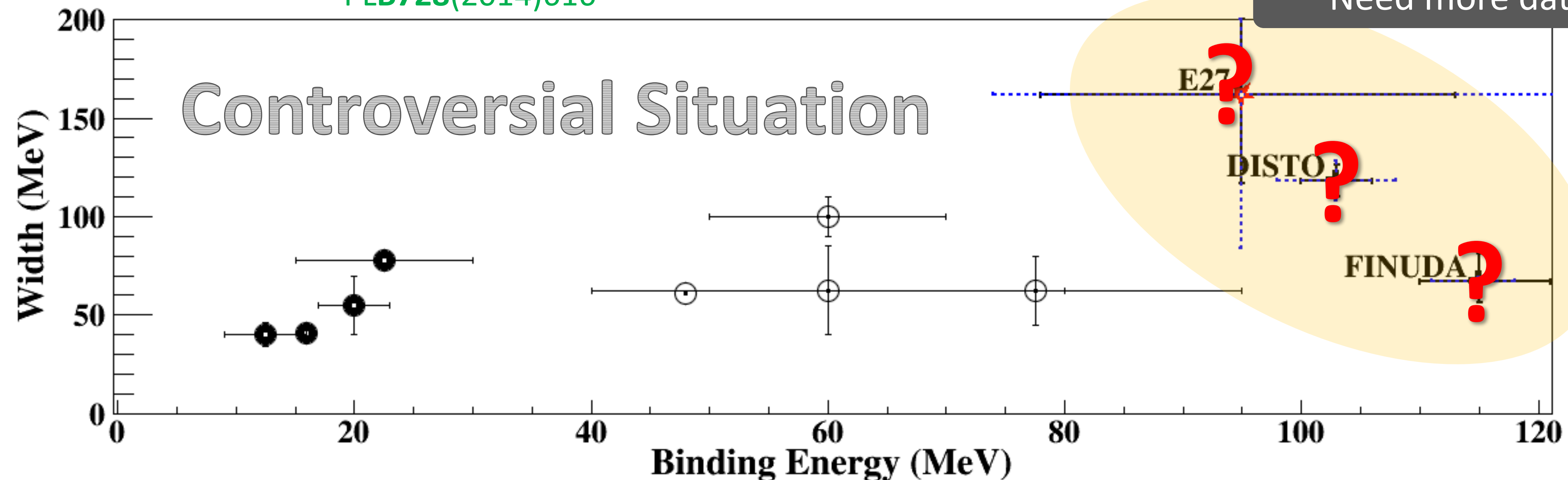

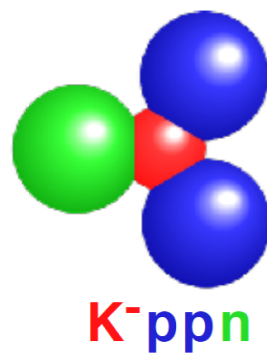

$\bar{K}NNN$ Searches so far

E471/E549@KEK

$^4\text{He}(\text{stopped-}K^-, p/n/\Upsilon d)$

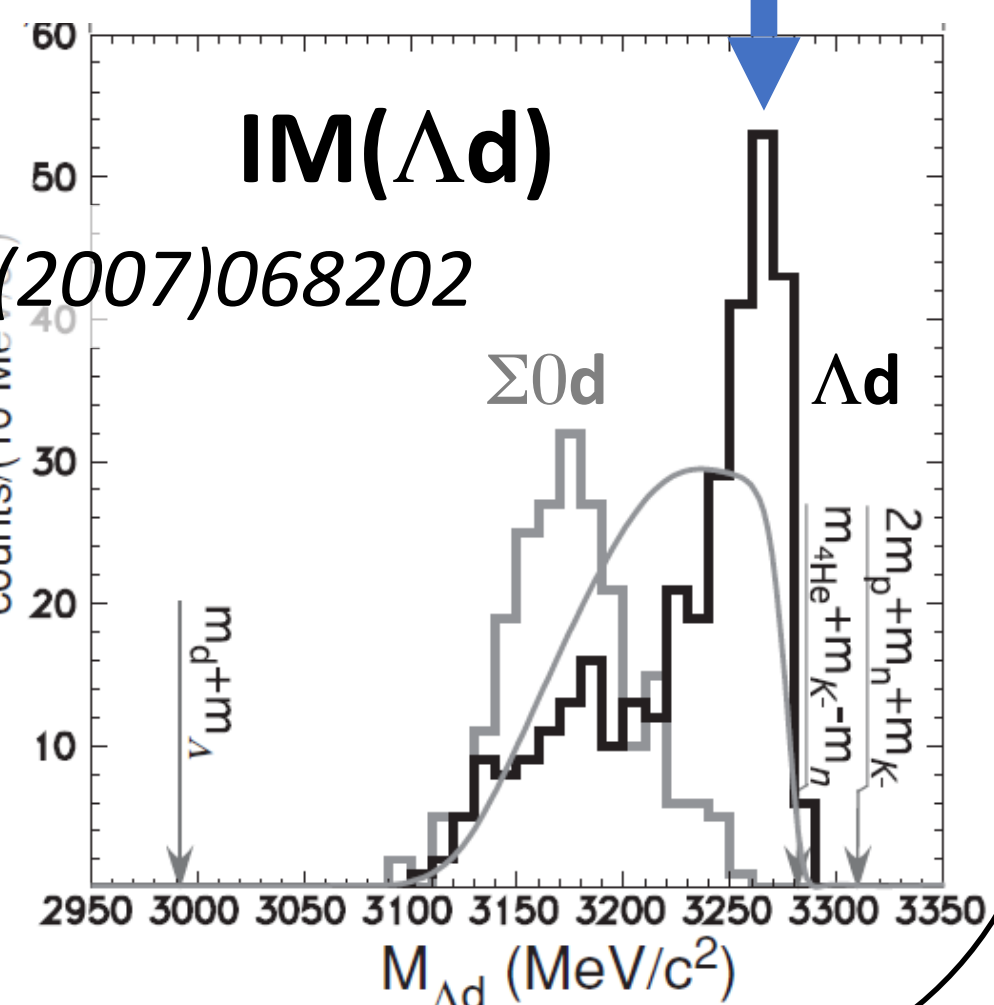
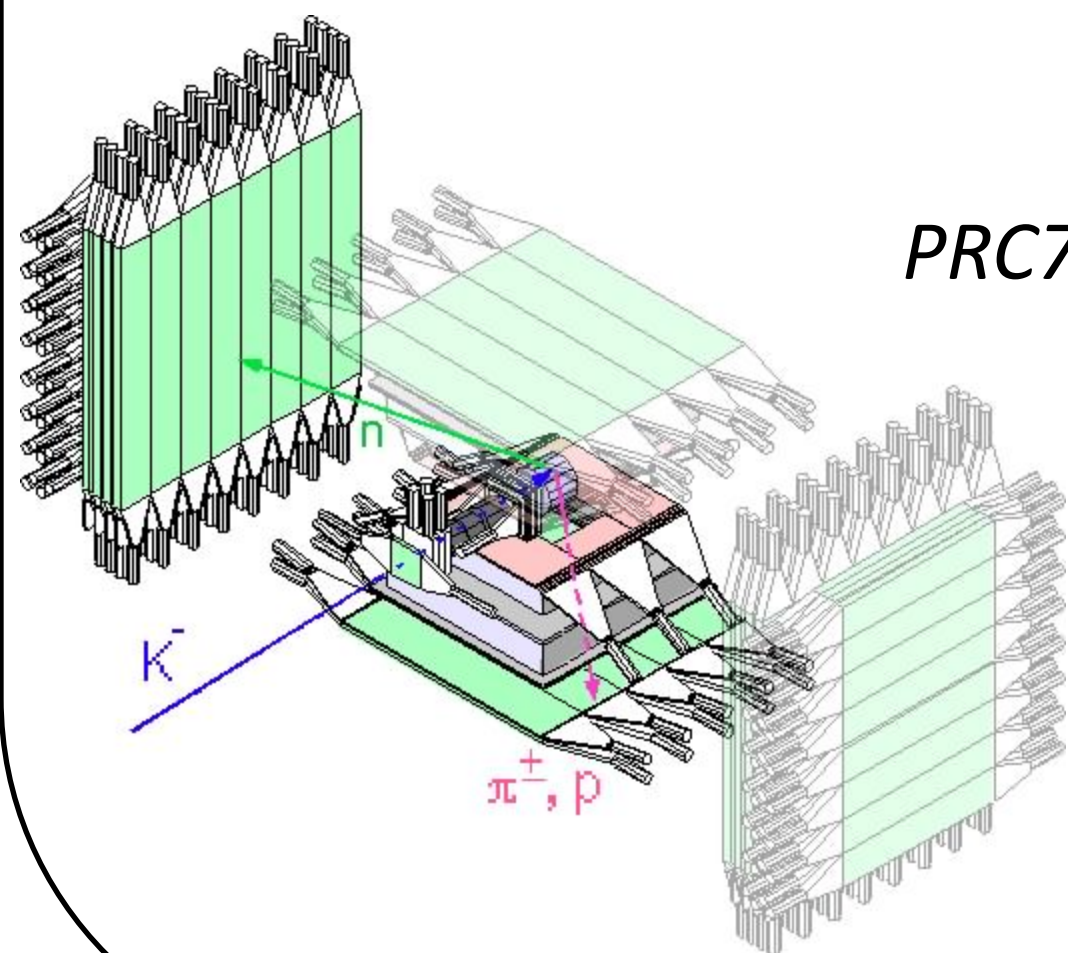
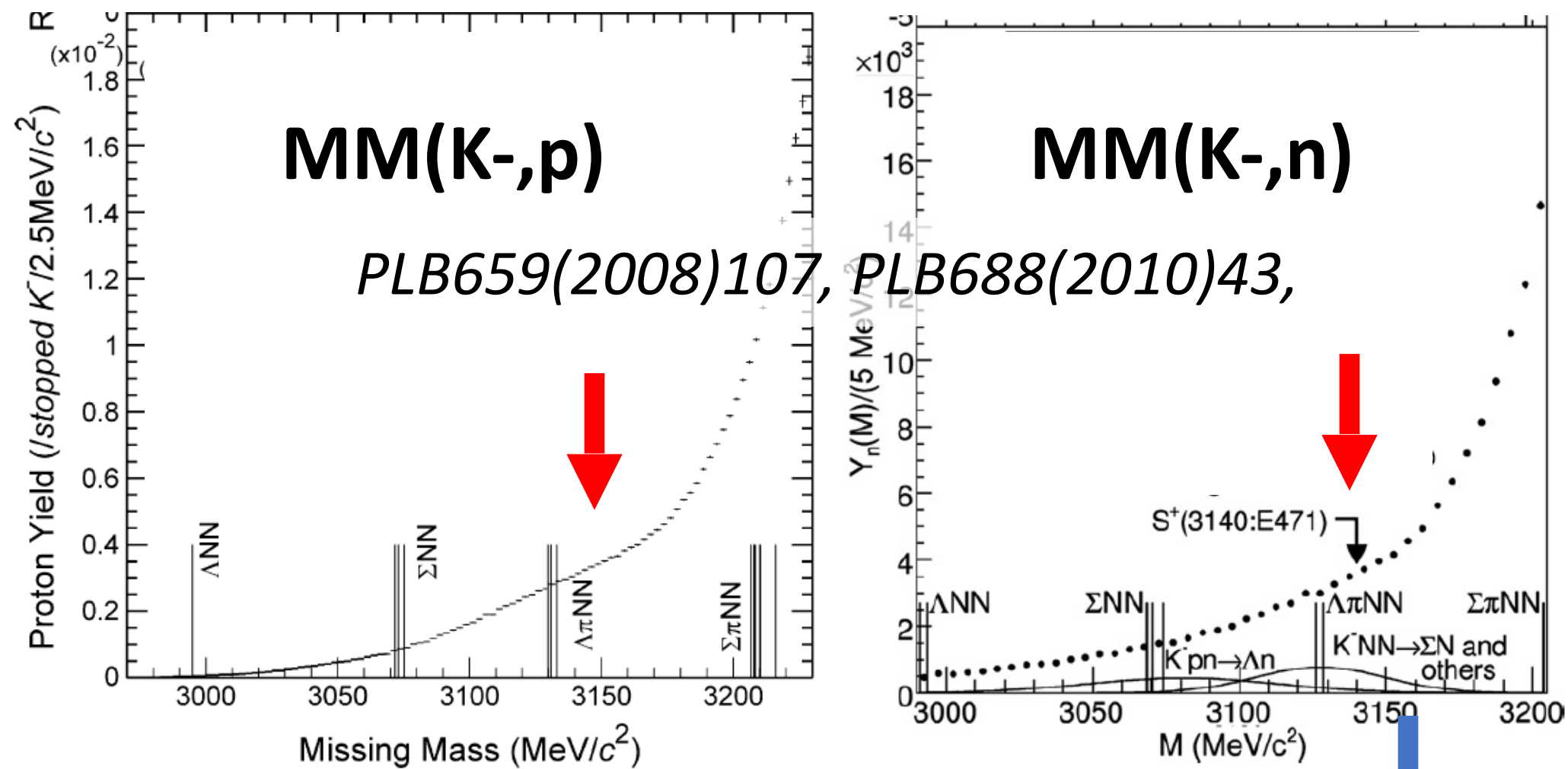

FINUDA@DAΦNE

$\text{Li}/\text{C}(\text{stopped-}K^-, \Lambda d)$

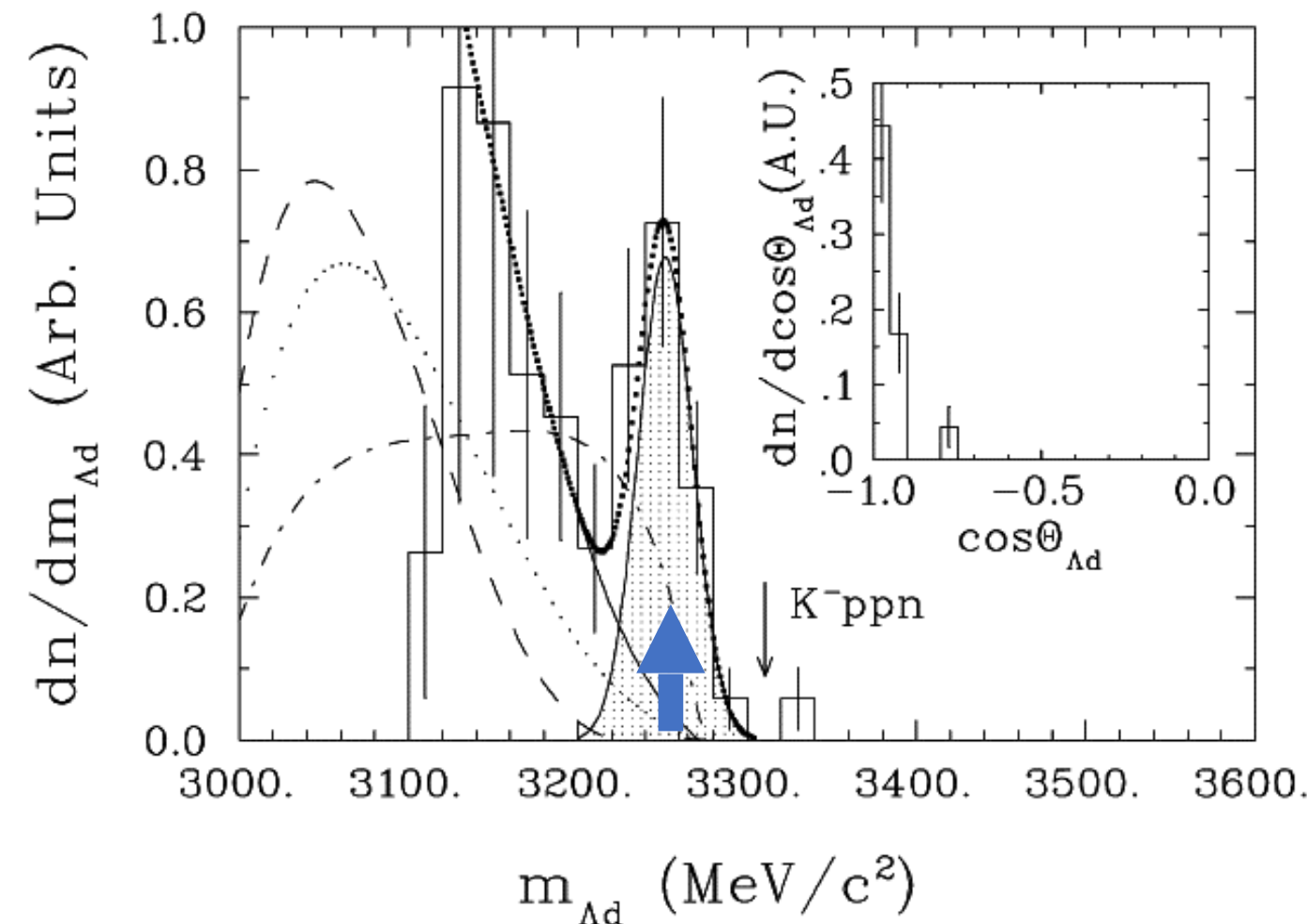

PLB654(2007)80

FOPI@GSI

Λd in Ni+Ni

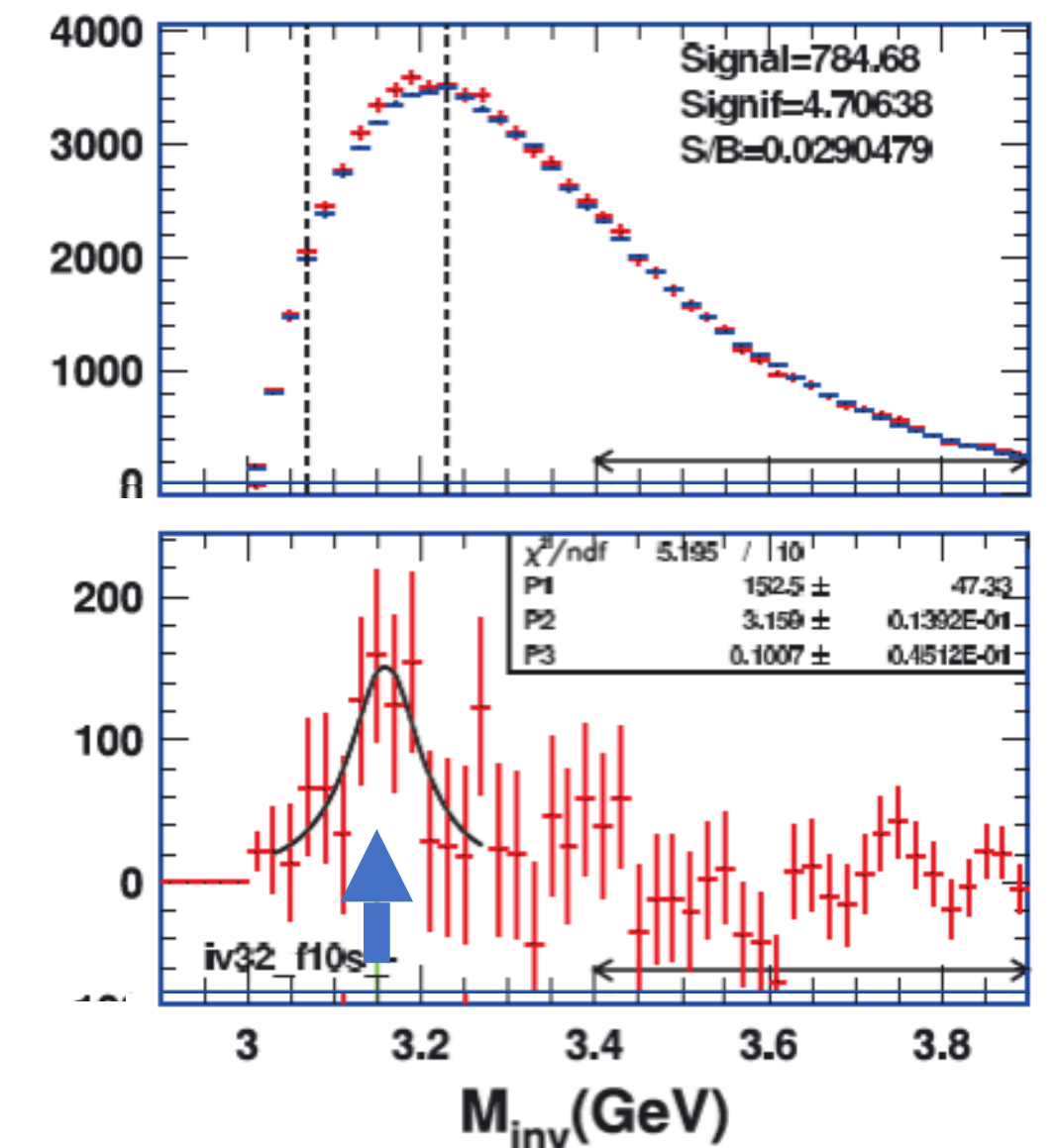

EXA05 Conference (2005)

No conclusive results.

multi-N absorption in stopped-K reaction makes interpretation difficult

The detail can be found:

— in a review —

$\bar{K}N$ interaction study via kaonic atom

Search for $\bar{K}NN$ nuclear bound state as a natural extension of $\Lambda(1405) \equiv \bar{K}N$

Recent results on \bar{K} bound state

This is a fee-based literature.

Kaonic Nuclei from the Experimental Viewpoint

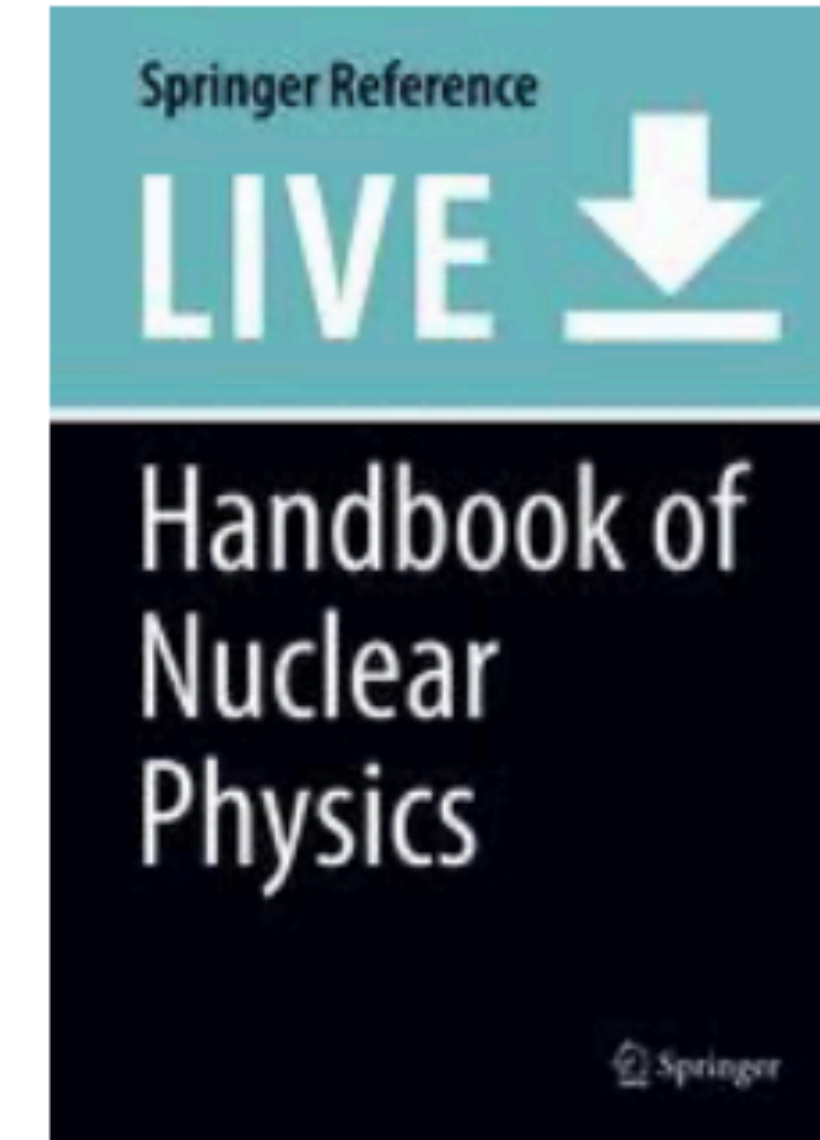

Iwasaki, M. (2022).

Kaonic Nuclei from the Experimental Viewpoint.

In: Tanihata, I., Toki, H., Kajino, T. (eds)

Handbook of Nuclear Physics . Springer, Singapore.

https://doi.org/10.1007/978-981-15-8818-1_37-1

https://link.springer.com/referenceworkentry/10.1007/978-981-15-8818-1_37-1

Proposed K1.8BR Upgrade

- Shortened beam line to enhance Kaon yield

Shorten the beam line (~2.5m) by removing the final D5 magnet

with π/K ratio ~ 2

Relative beam-line length (m)	@ D5	@ D4
Present CDS	0	-3.7
New CDS	+1.2	-2.5

- K- yield increases by **~ 1.4 times @ 1.0 GeV/c**

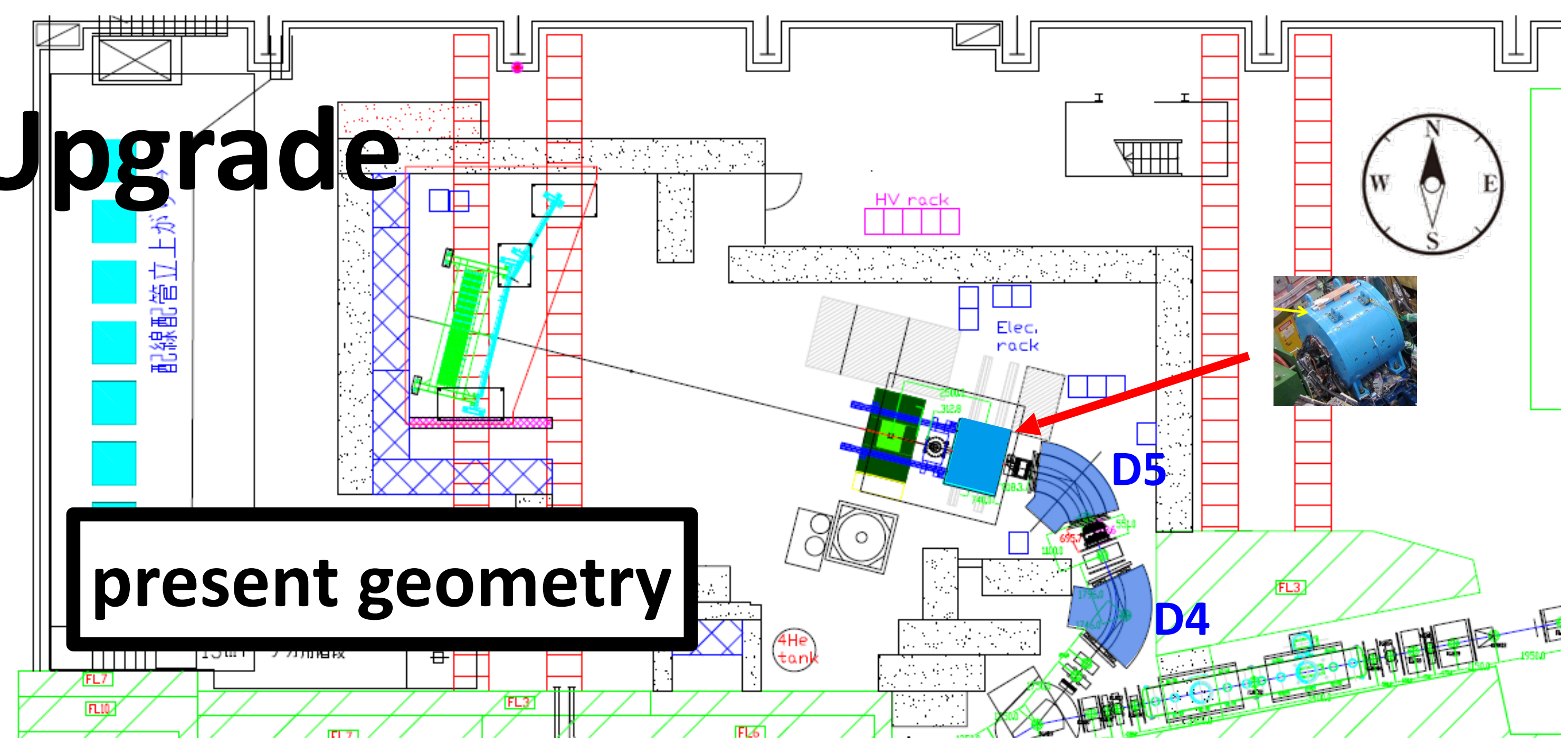

Proposed K1.8BR Upgrade

- Shortened beam line to enhance Kaon yield

Shorten the beam line (~2.5m) by removing the final D5 magnet

with π/K ratio ~ 2

Relative beam-line length (m)	@ D5	@ D4
Present CDS	0	-3.7
New CDS	+1.2	-2.5

➤ K- yield increases by **~ 1.4 times @ 1.0 GeV/c**

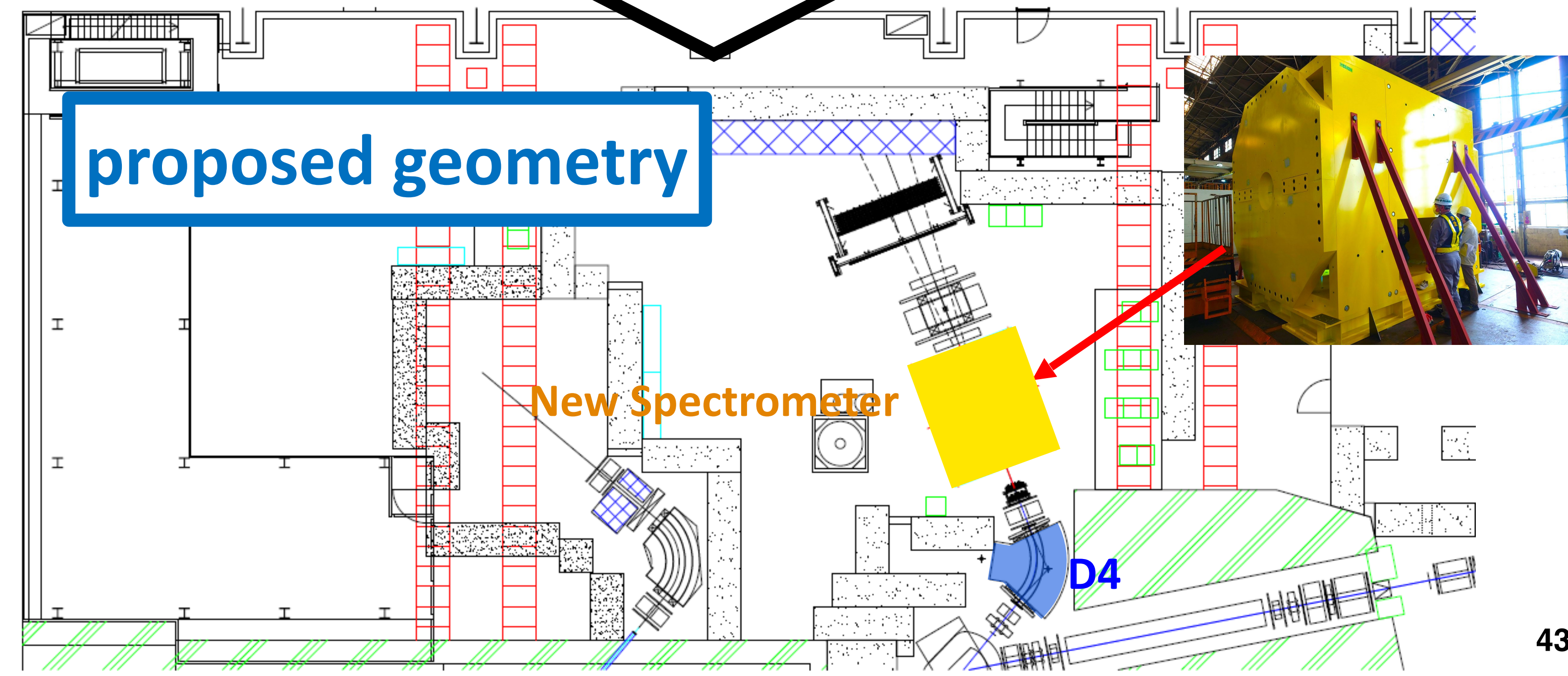
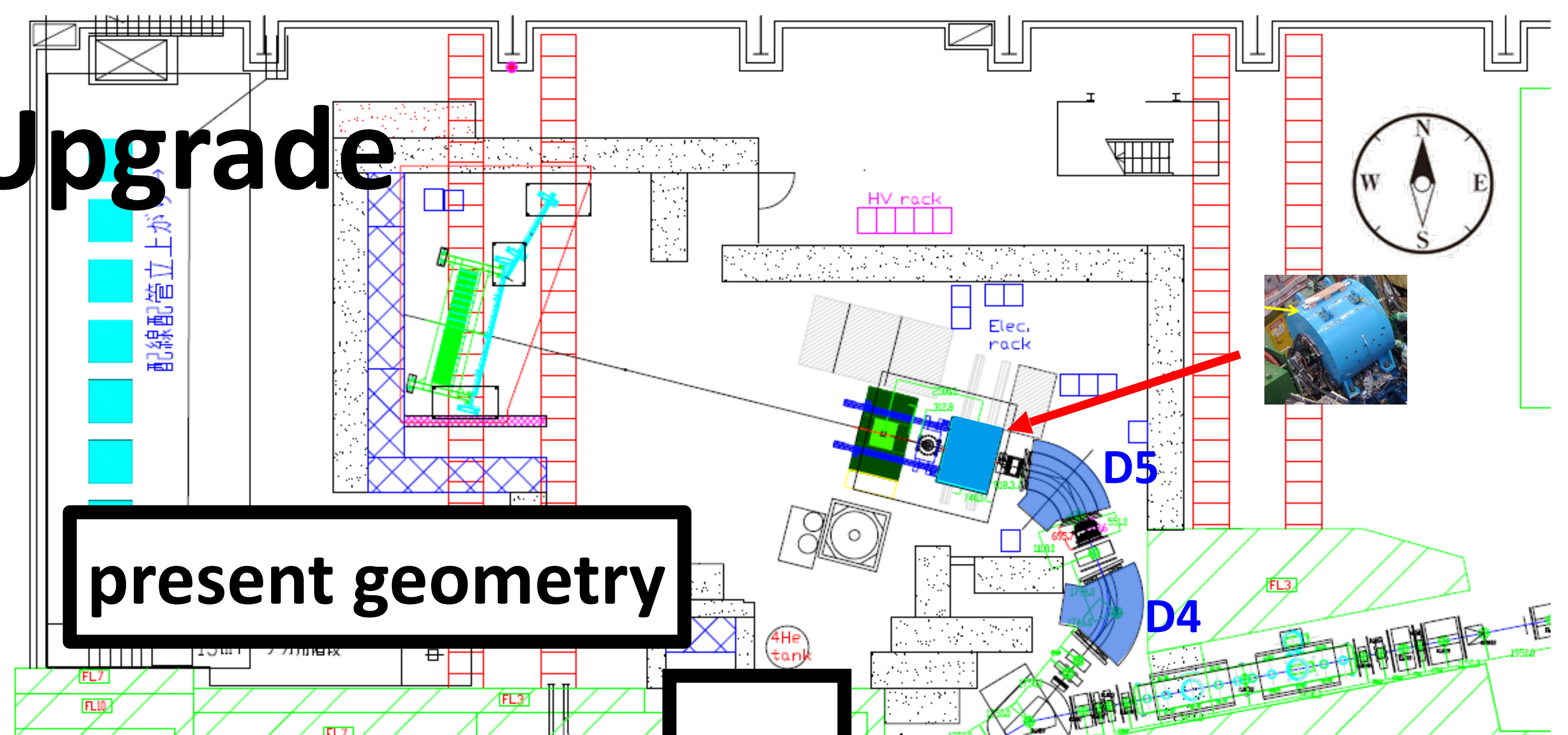

$K^- + {}^3\text{He} \rightarrow (\pi^- \Lambda p) + p$ reaction

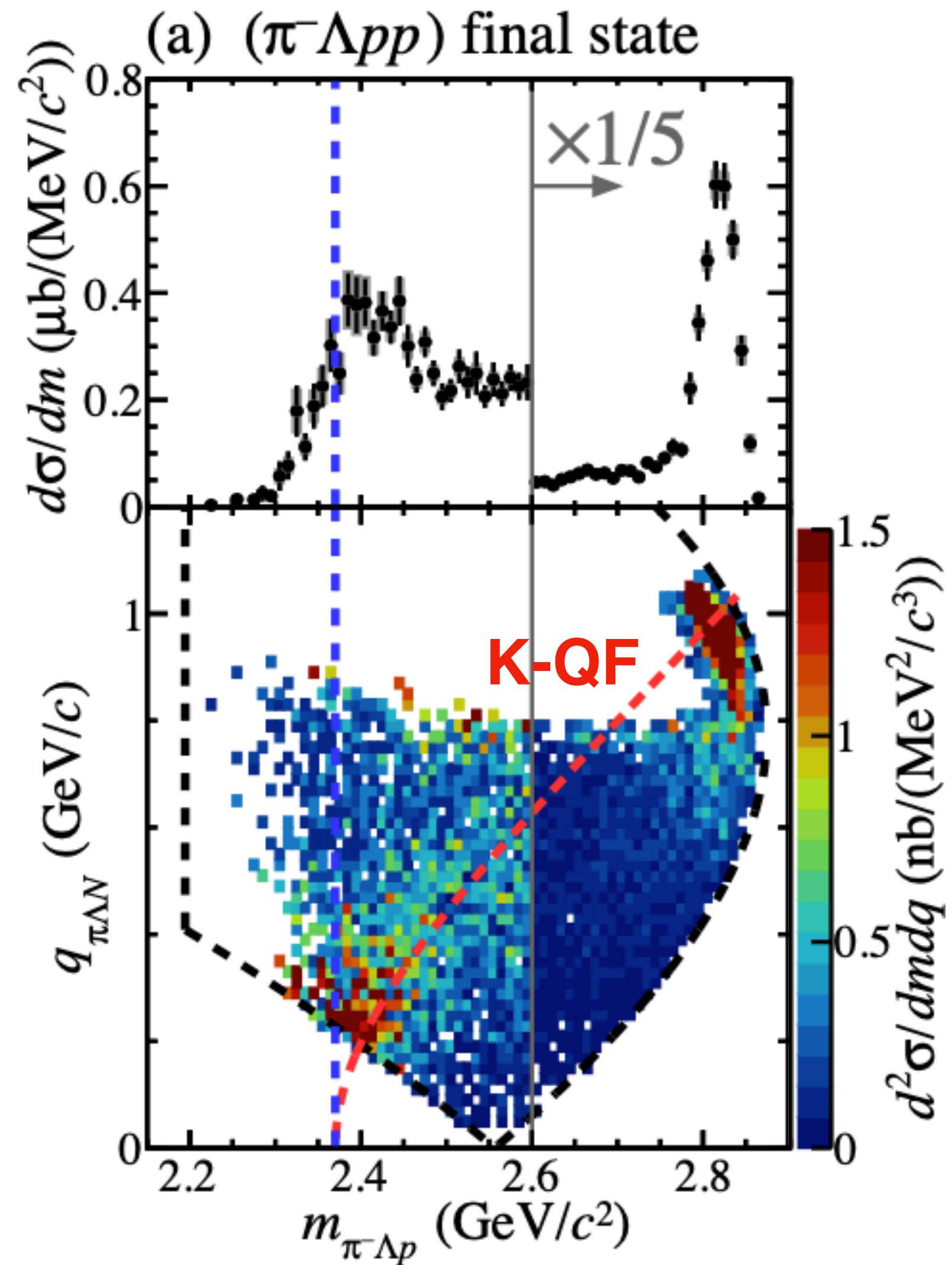

... analyzed by T. Yamaga

$K^- + {}^3\text{He} \rightarrow (\pi^- \Lambda p) + p$ reaction

consistent with $K^- + {}^3\text{He} \rightarrow \Lambda p n$ reaction
branch seems to be order bigger

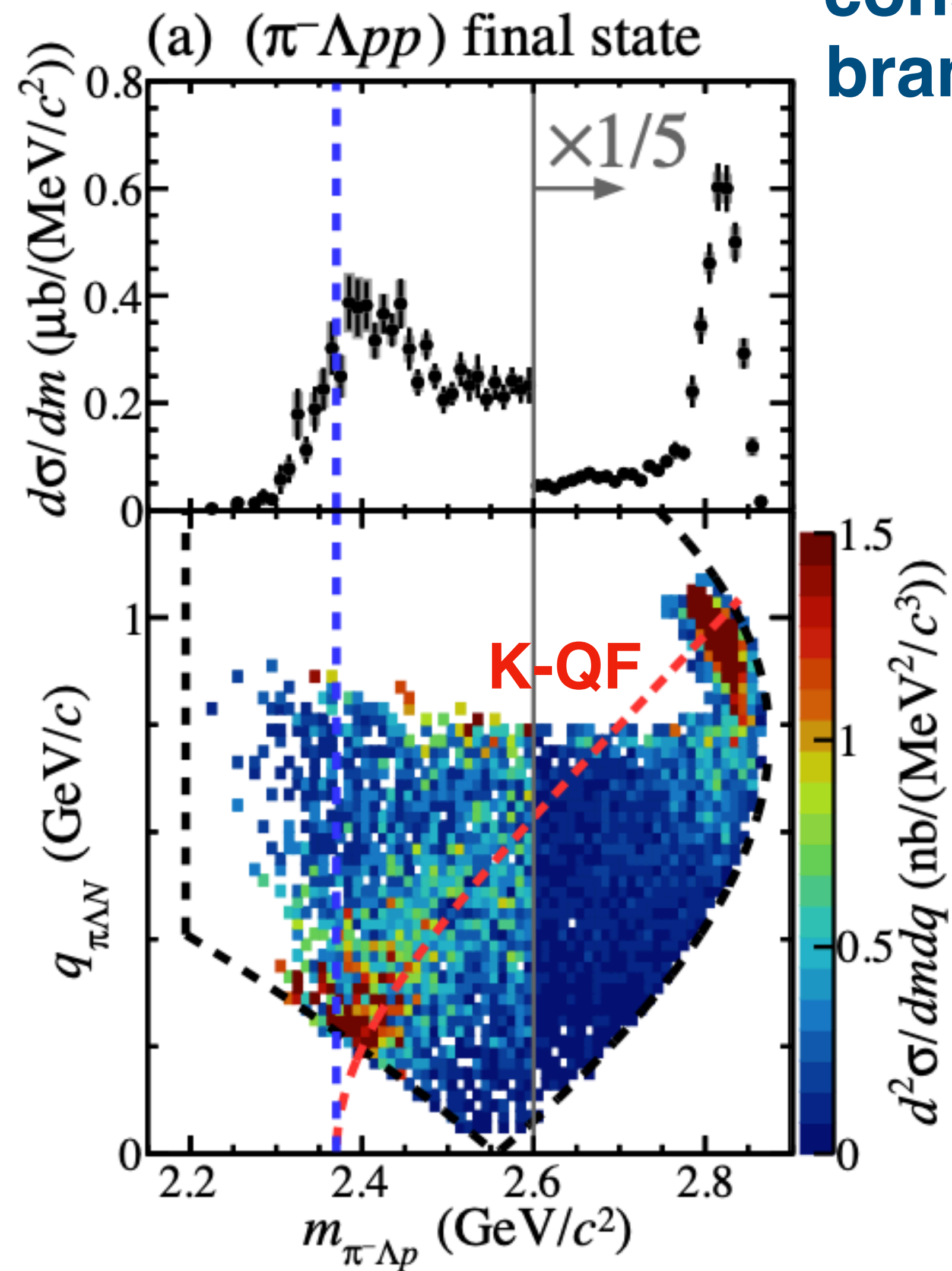

... analyzed by T. Yamaga

$K^- + {}^3\text{He} \rightarrow (\pi^- \Lambda p) + p$ reaction

consistent with $K^- + {}^3\text{He} \rightarrow \Lambda p n$ reaction
branch seems to be order bigger

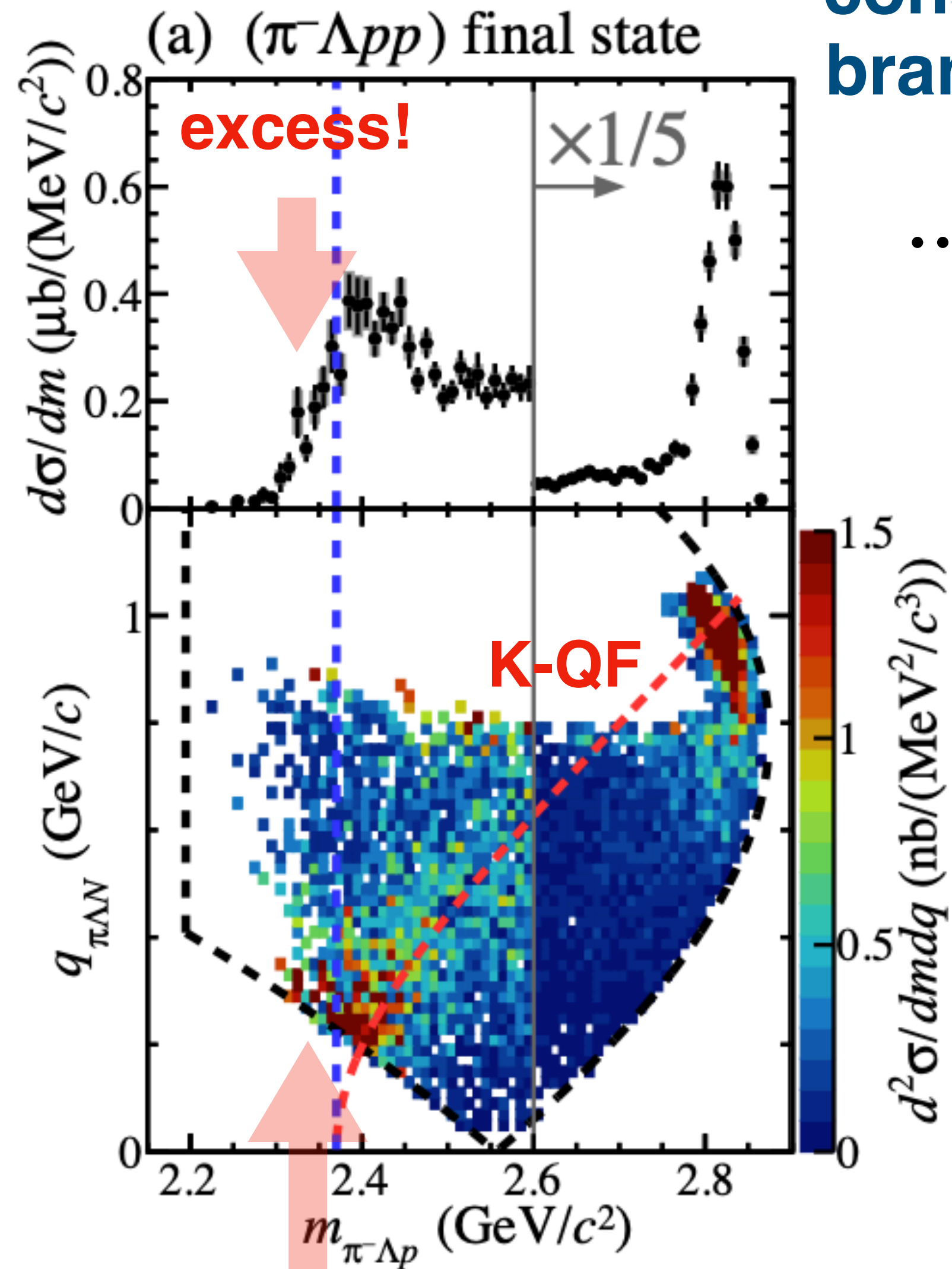

... *excess* is not easy to see ...

excess!

... analyzed by T. Yamaga

$K^- + {}^3\text{He} \rightarrow (\pi^- \Lambda p) + p$ reaction

consistent with $K^- + {}^3\text{He} \rightarrow \Lambda p n$ reaction
branch seems to be order bigger

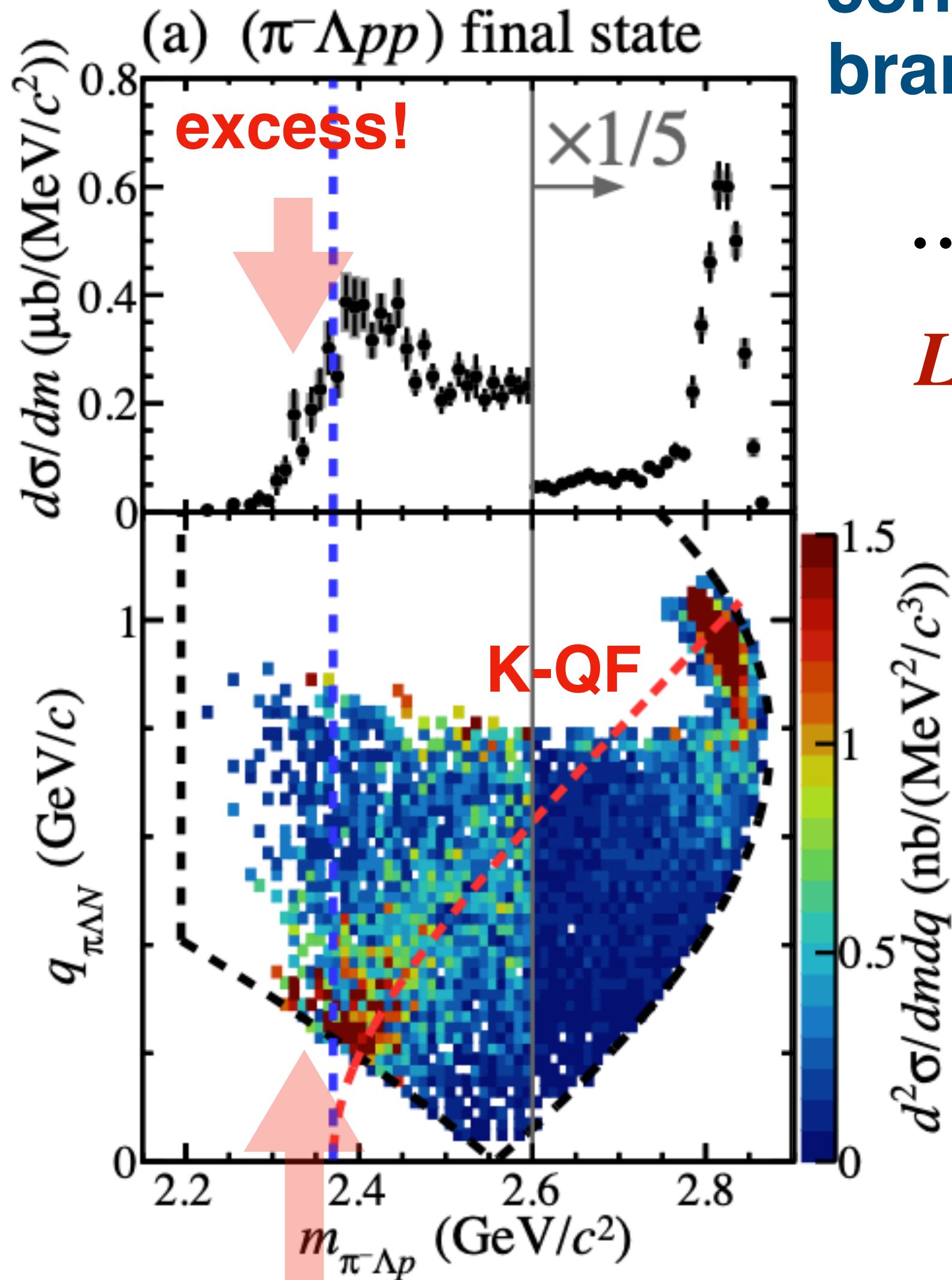
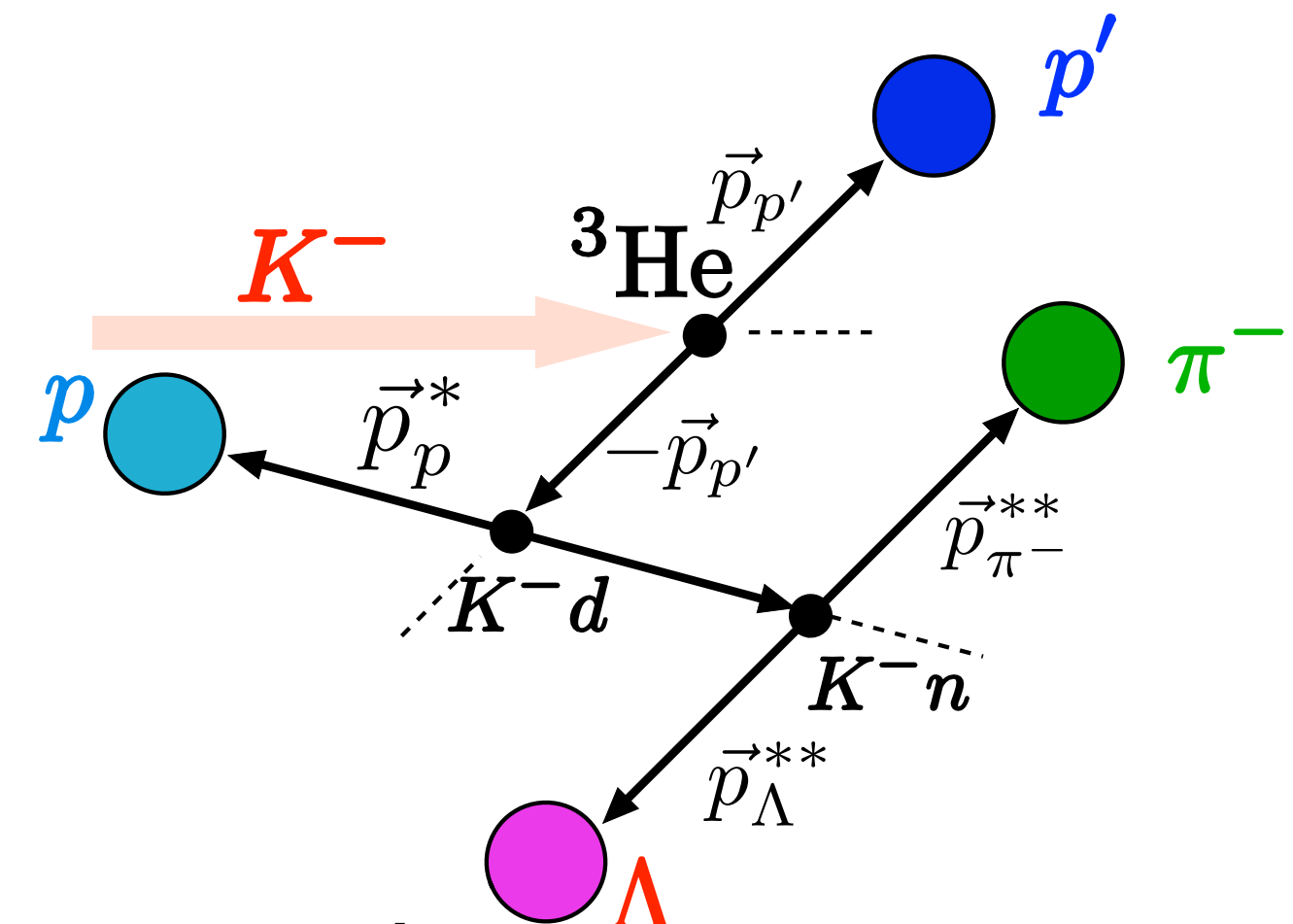

... *excess* is not easy to see ...

Let's normalize event density by 4-body phase space

The normalization by 4-body phase space, i.e., final-state-density

$$\rho_{(\pi^- \Lambda p p')} = \frac{d^2 N_{(\pi^- \Lambda p p')}}{dm_{\{\pi^- \Lambda p\}} dm_{\{\pi^- \Lambda\}}}$$

$$\propto p_{p'} \times p_p^* \times p_{\Lambda}^{**}$$

... analyzed by T. Yamaga

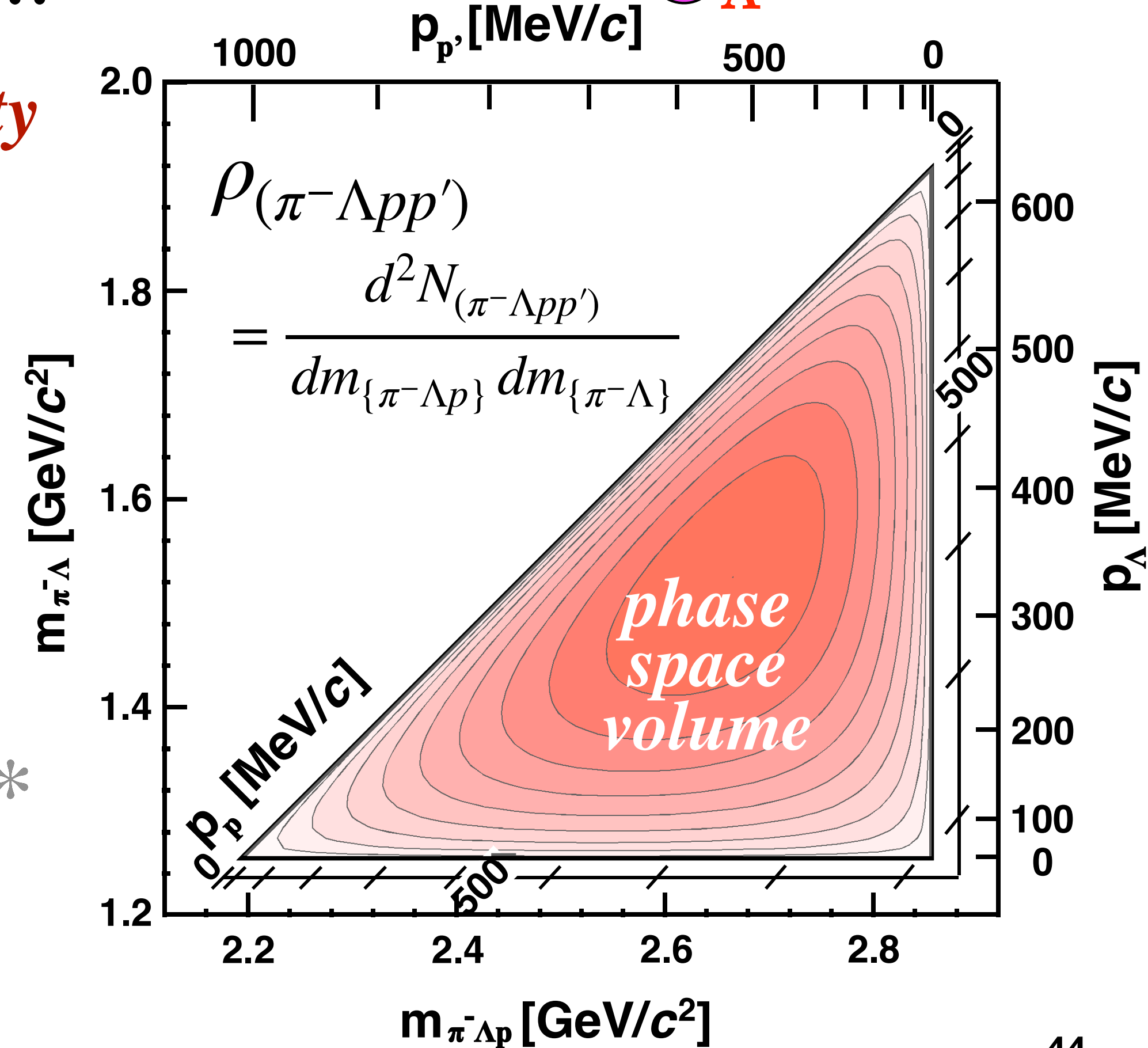

excess!

$K^- + {}^3\text{He} \rightarrow (\pi^- \Lambda p) + p$ reaction

consistent with $K^- + {}^3\text{He} \rightarrow \Lambda p n$ reaction
branch seems to be order bigger

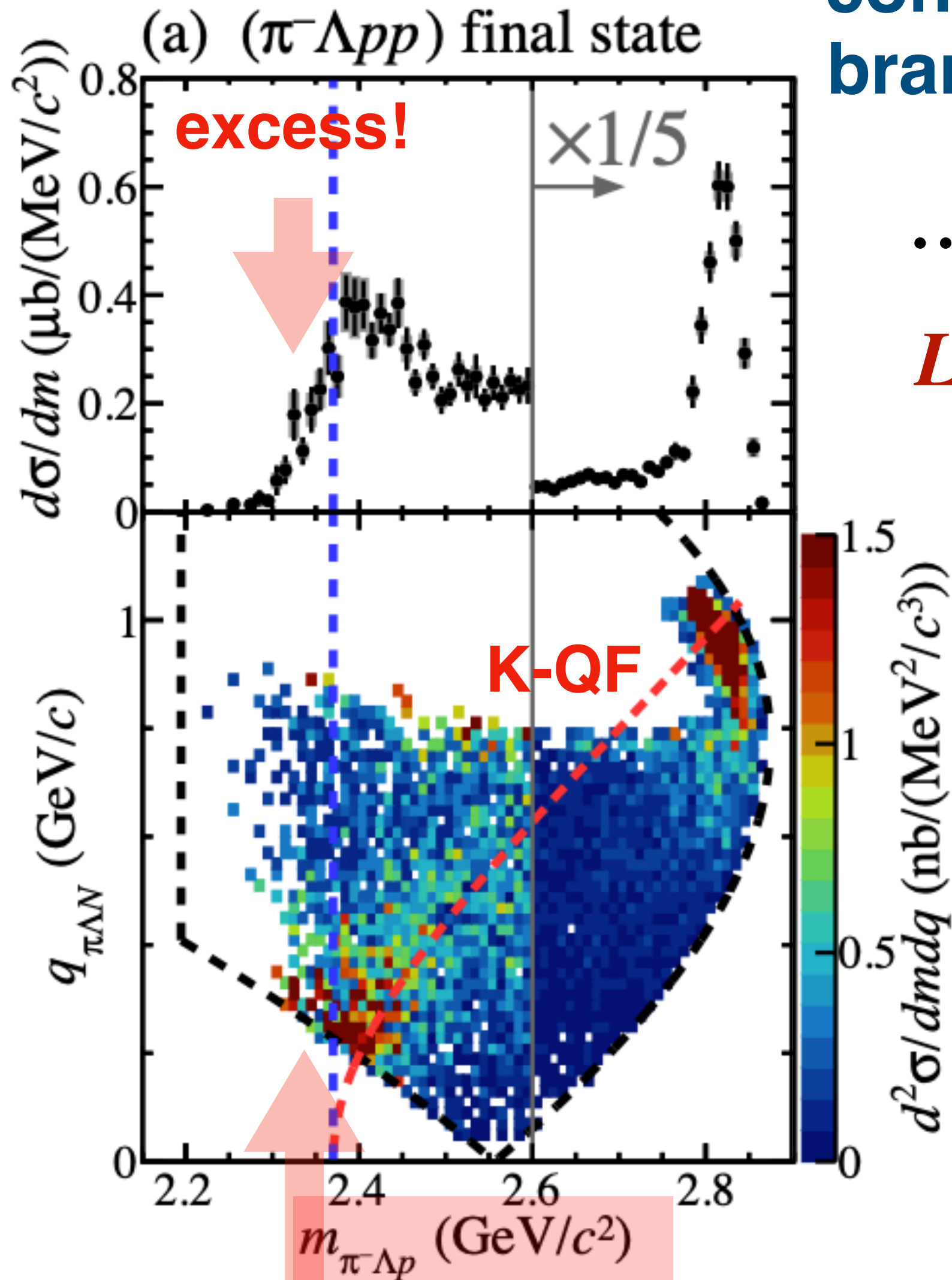

... *excess* is not easy to see ...

Let's normalize event density by 4-body phase space

The normalization by 4-body phase space, i.e., final-state-density

$$\rho_{(\pi^- \Lambda p p')} = \frac{d^2 N_{(\pi^- \Lambda p p')}}{dm_{\{\pi^- \Lambda p\}} dm_{\{\pi^- \Lambda\}}}$$

$$\propto p_{p'} \times p_p^* \times p_\Lambda^{**}$$

... analyzed by T. Yamaga

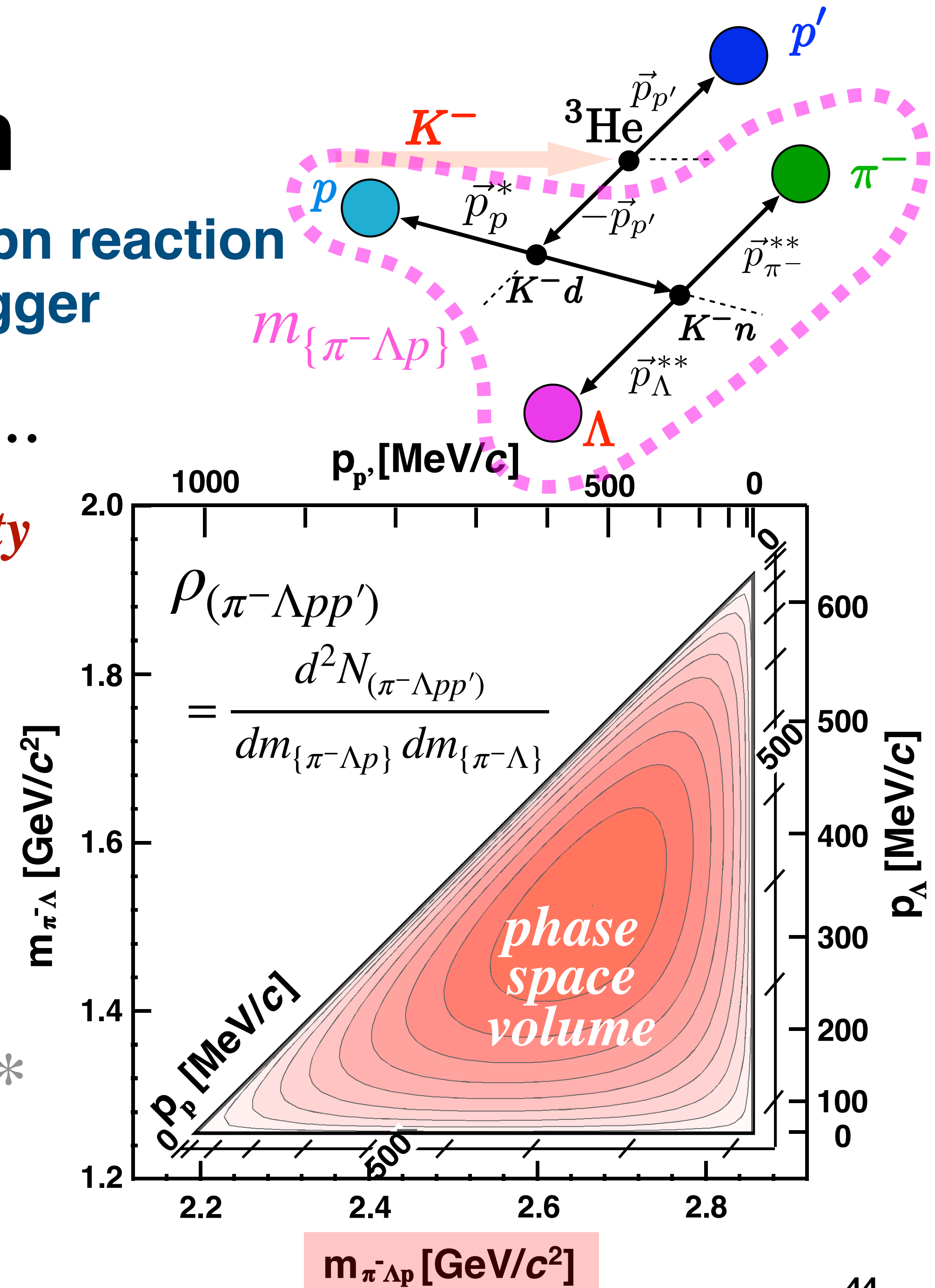

$K^- + {}^3\text{He} \rightarrow (\pi^- \Lambda p) + p$ reaction

consistent with $K^- + {}^3\text{He} \rightarrow \Lambda p n$ reaction
branch seems to be order bigger

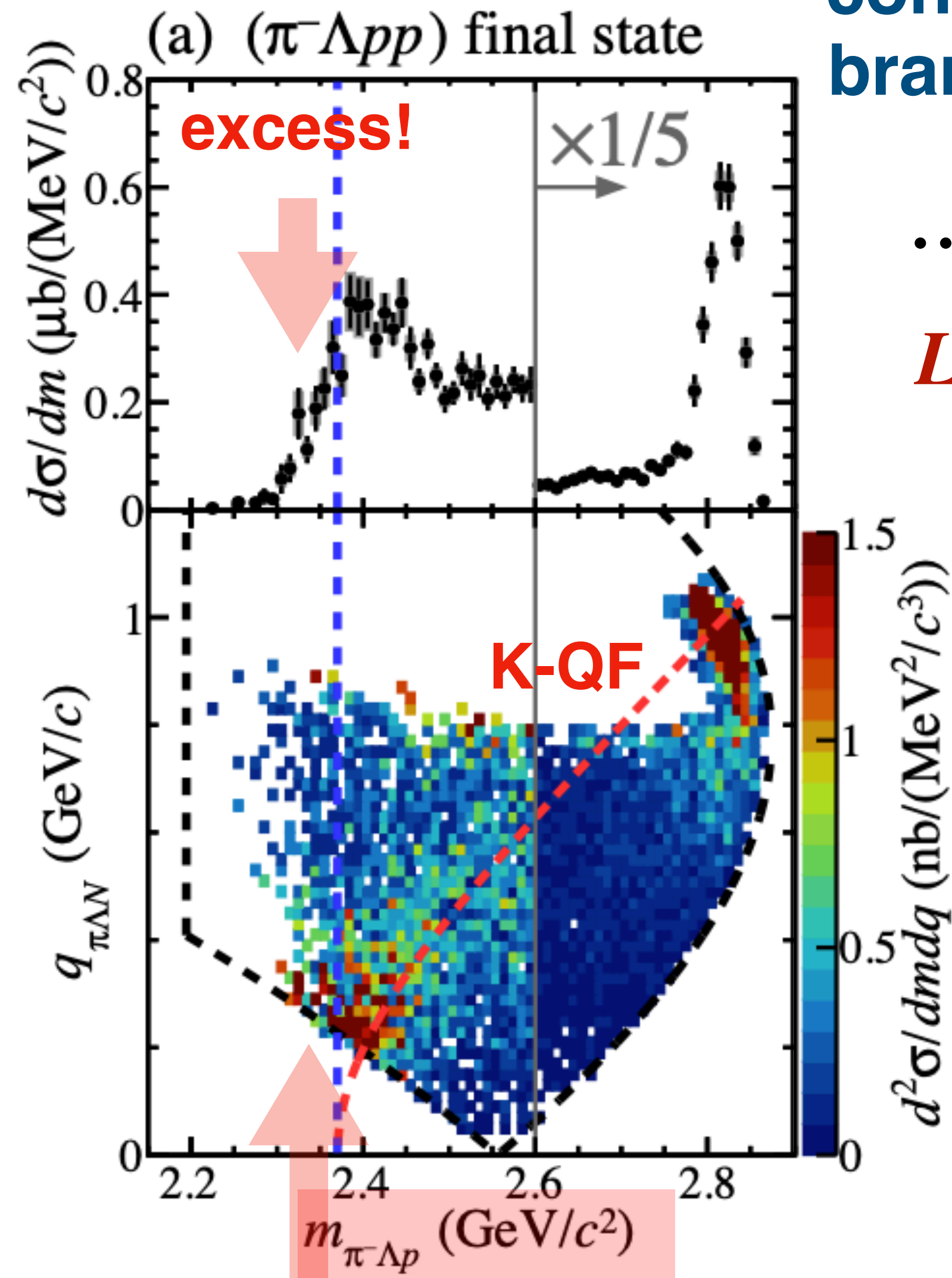

... *excess* is not easy to see ...

Let's normalize event density by 4-body phase space

The normalization by 4-body phase space, i.e., final-state-density

$$\rho_{(\pi^- \Lambda p p')} = \frac{d^2 N_{(\pi^- \Lambda p p')}}{dm_{\{\pi^- \Lambda p\}} dm_{\{\pi^- \Lambda\}}}$$

$$\propto p_{p'} \times p_p^* \times p_\Lambda^{**}$$

... analyzed by T. Yamaga

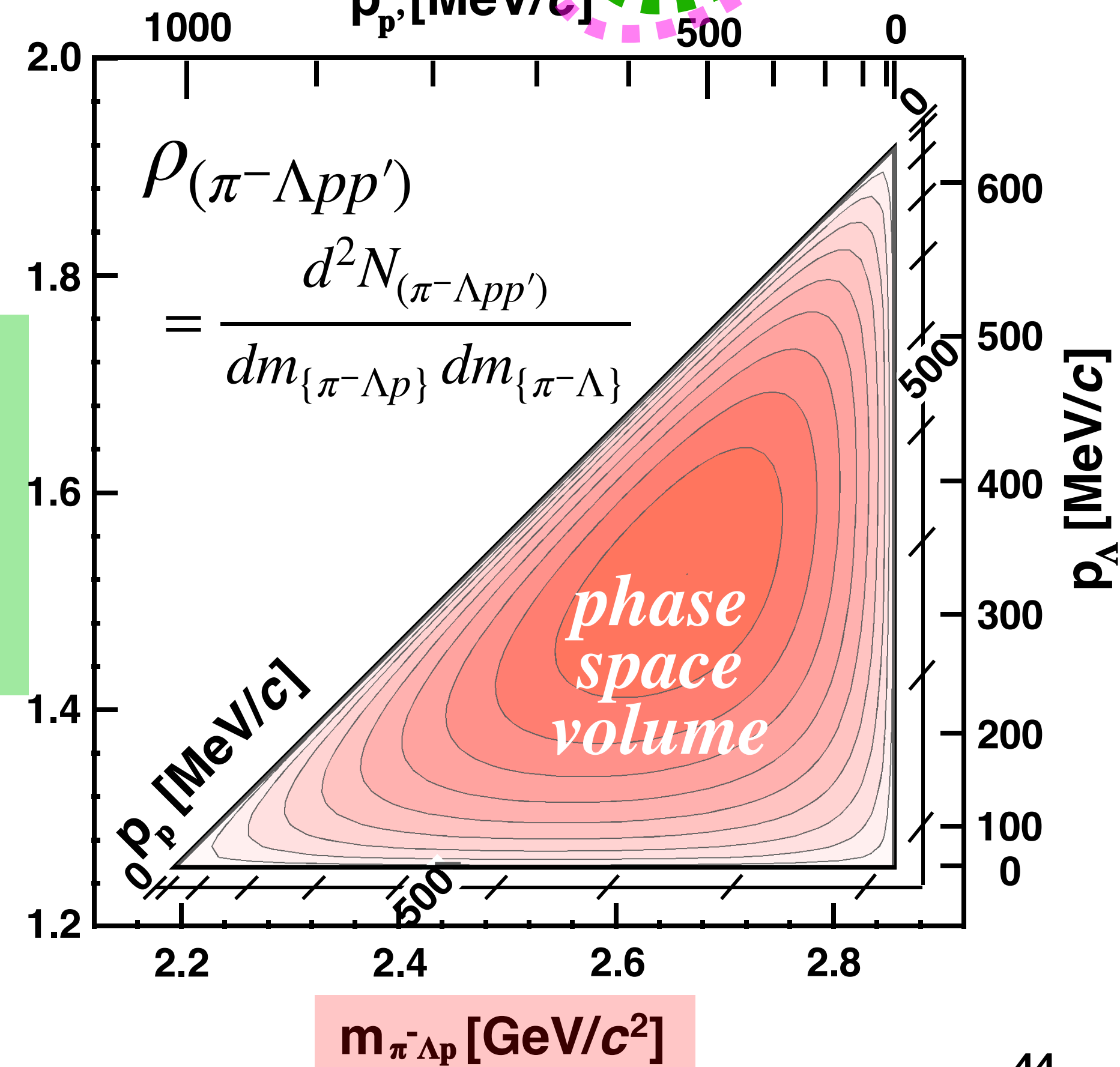
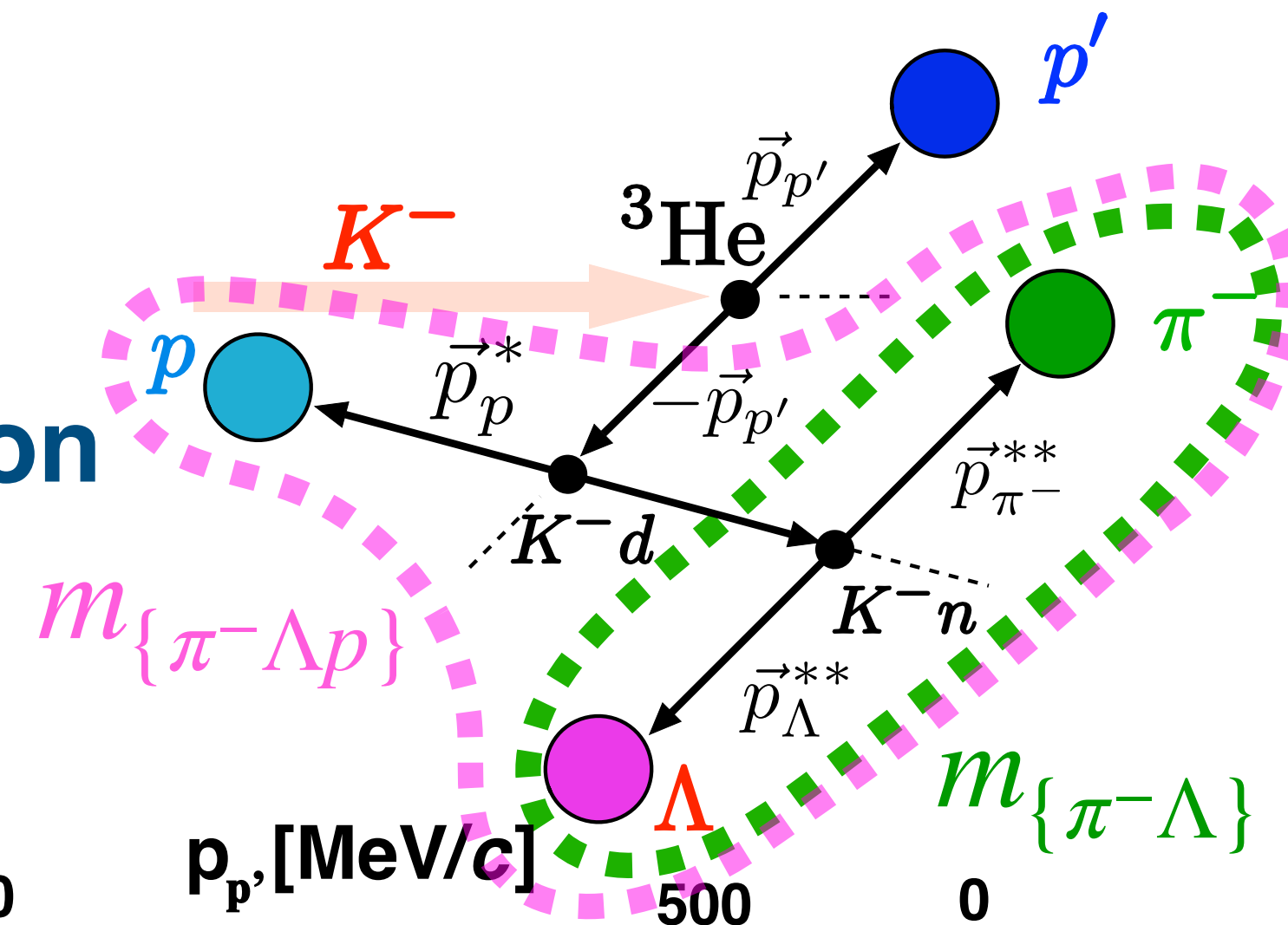

excess!

$K^- + {}^3\text{He} \rightarrow (\pi^- \Lambda p) + p$ reaction

consistent with $K^- + {}^3\text{He} \rightarrow \Lambda p n$ reaction
branch seems to be order bigger

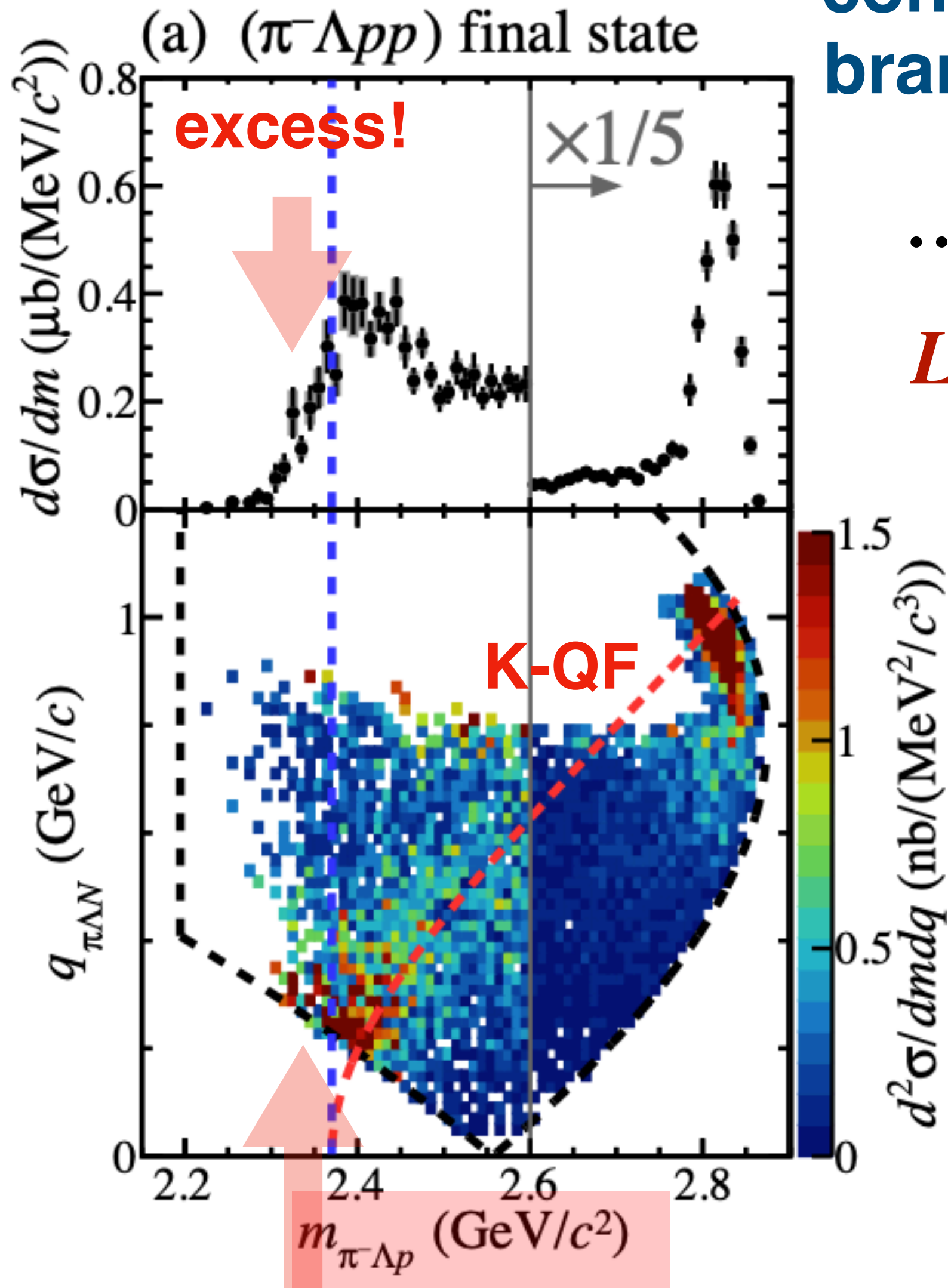
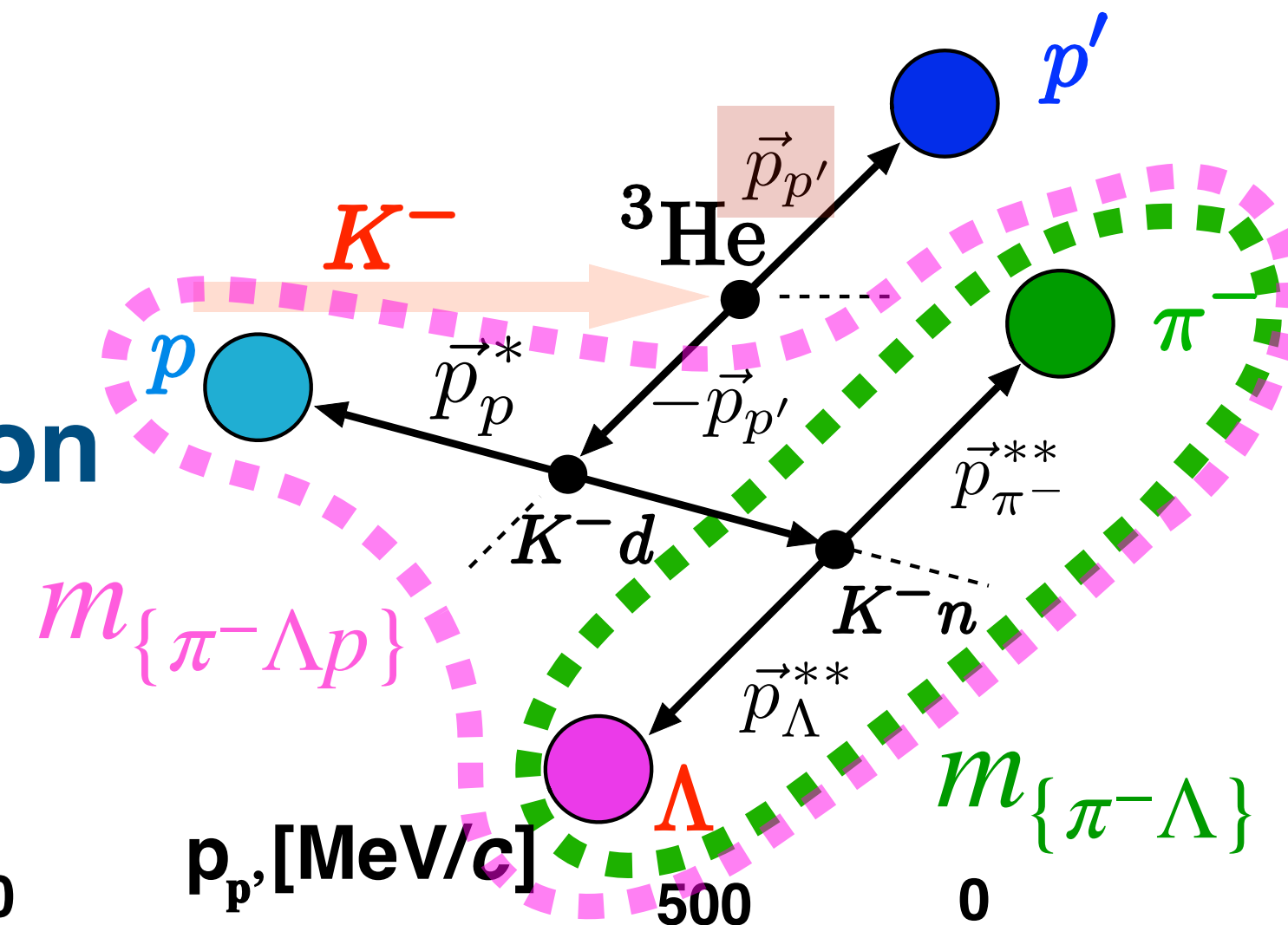

... *excess* is not easy to see ...

Let's normalize event density by 4-body phase space

The normalization by 4-body phase space, i.e., final-state-density

$$\rho_{(\pi^- \Lambda p p')} = \frac{d^2 N_{(\pi^- \Lambda p p')}}{dm_{\{\pi^- \Lambda p\}} dm_{\{\pi^- \Lambda\}}}$$

$$\propto p_{p'} \times p_p^* \times p_\Lambda^{**}$$

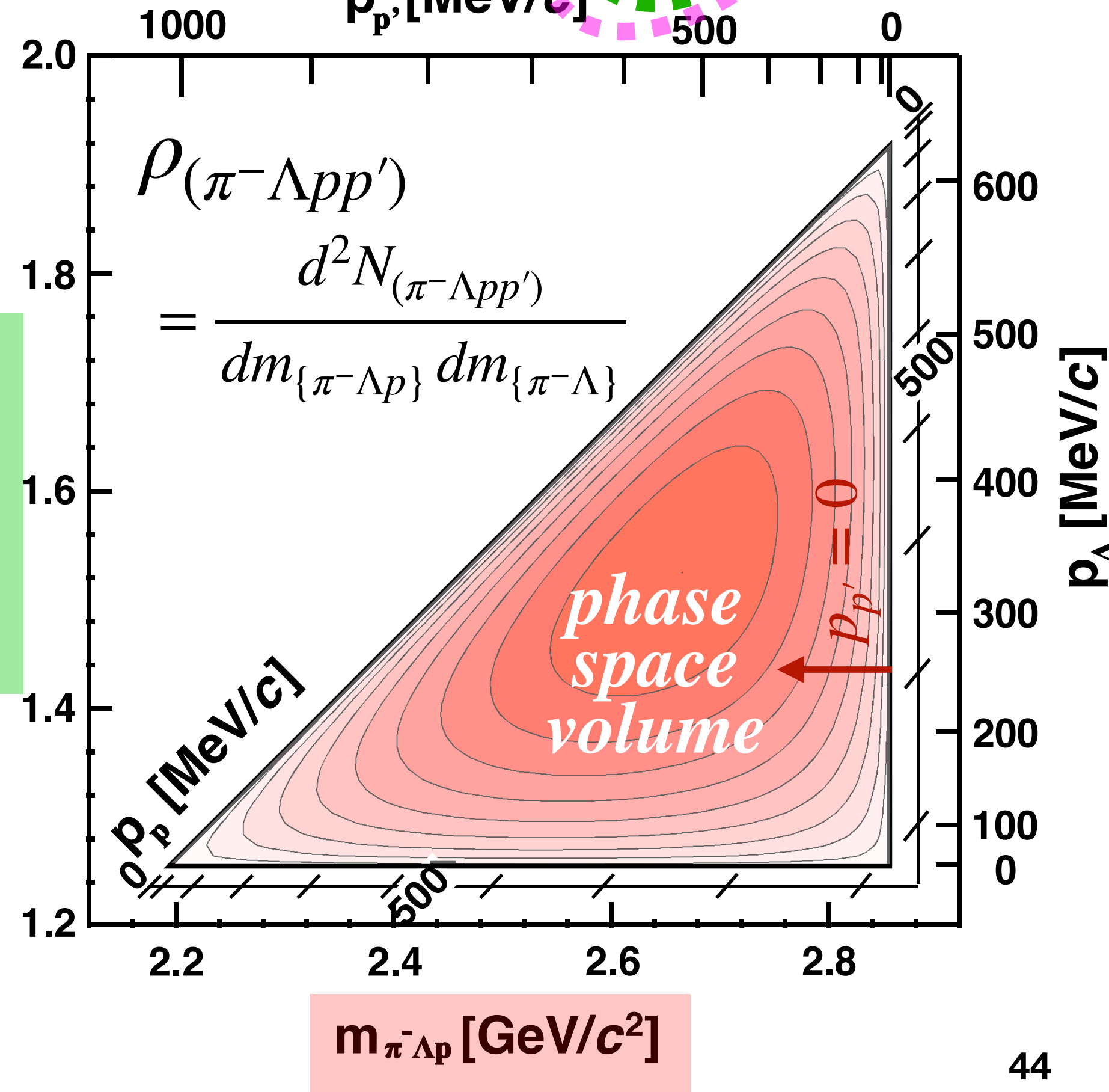

... analyzed by T. Yamaga

$K^- + {}^3\text{He} \rightarrow (\pi^- \Lambda p) + p$ reaction

consistent with $K^- + {}^3\text{He} \rightarrow \Lambda p n$ reaction
branch seems to be order bigger

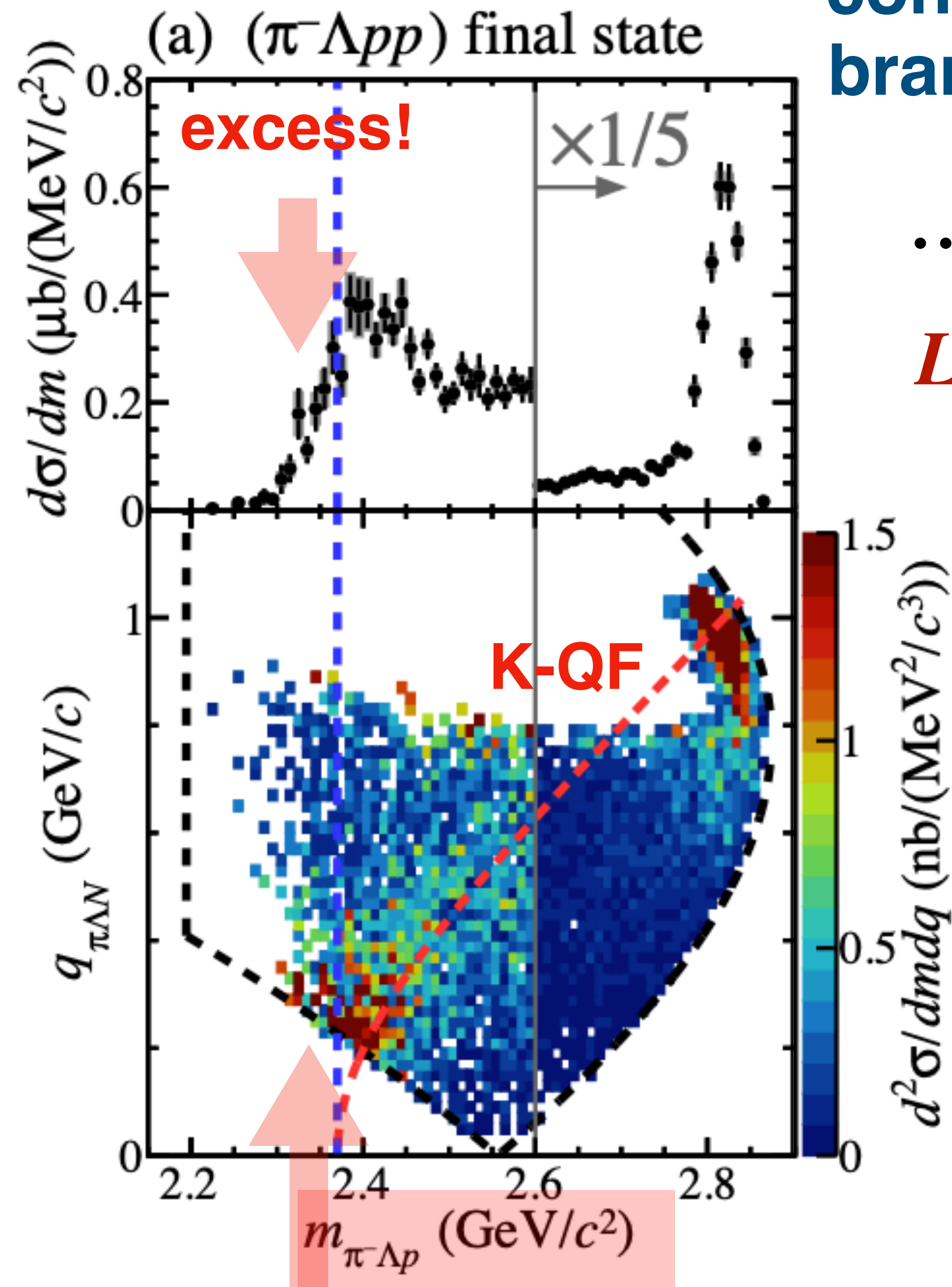

... *excess* is not easy to see ...

Let's normalize event density by 4-body phase space

The normalization by 4-body phase space, i.e., final-state-density

$$\rho_{(\pi^- \Lambda p p')} = \frac{d^2 N_{(\pi^- \Lambda p p')}}{dm_{\{\pi^- \Lambda p\}} dm_{\{\pi^- \Lambda\}}}$$

$$\propto p_{p'} \times p_p^* \times p_\Lambda^{**}$$

... analyzed by T. Yamaga

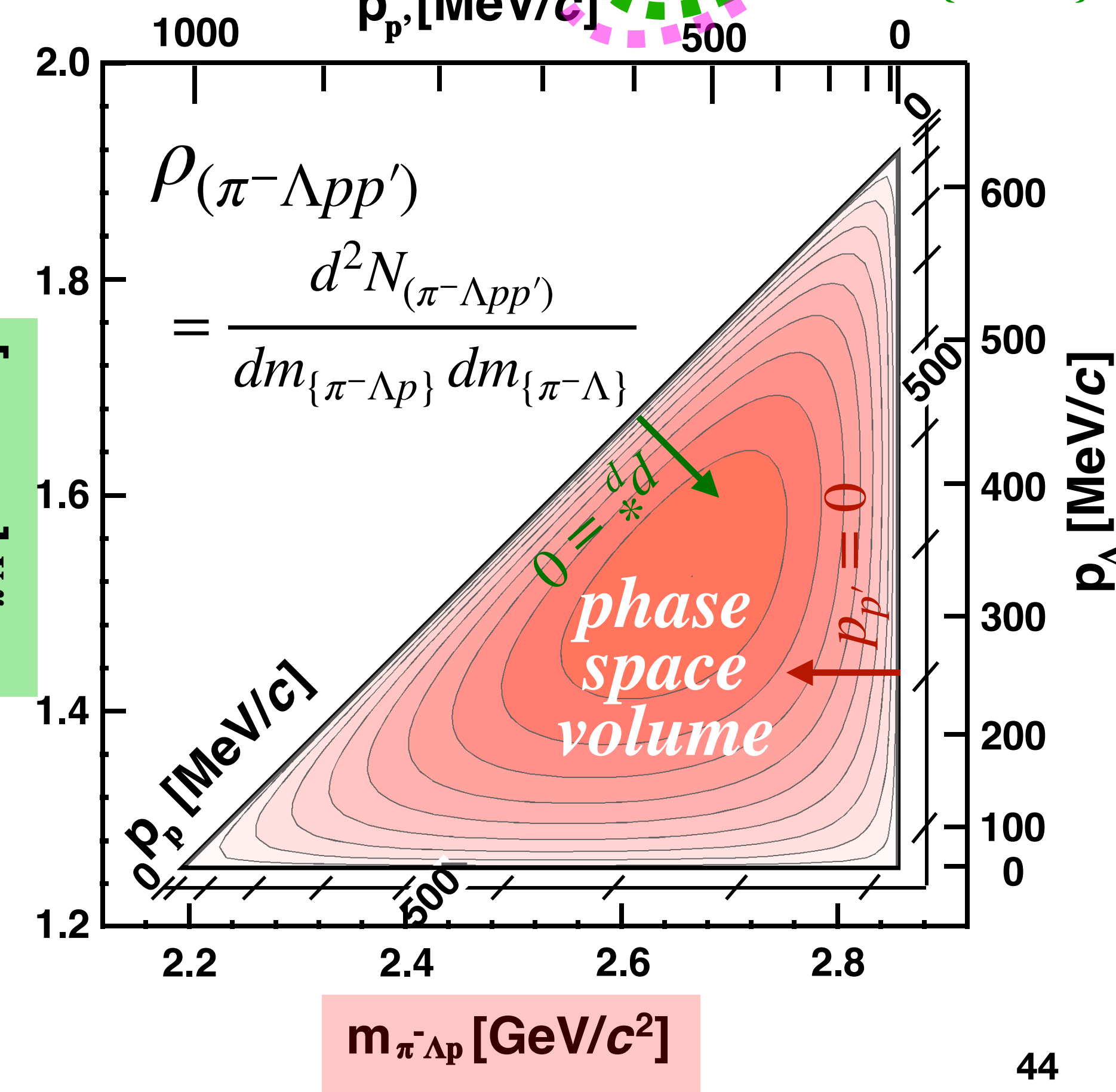
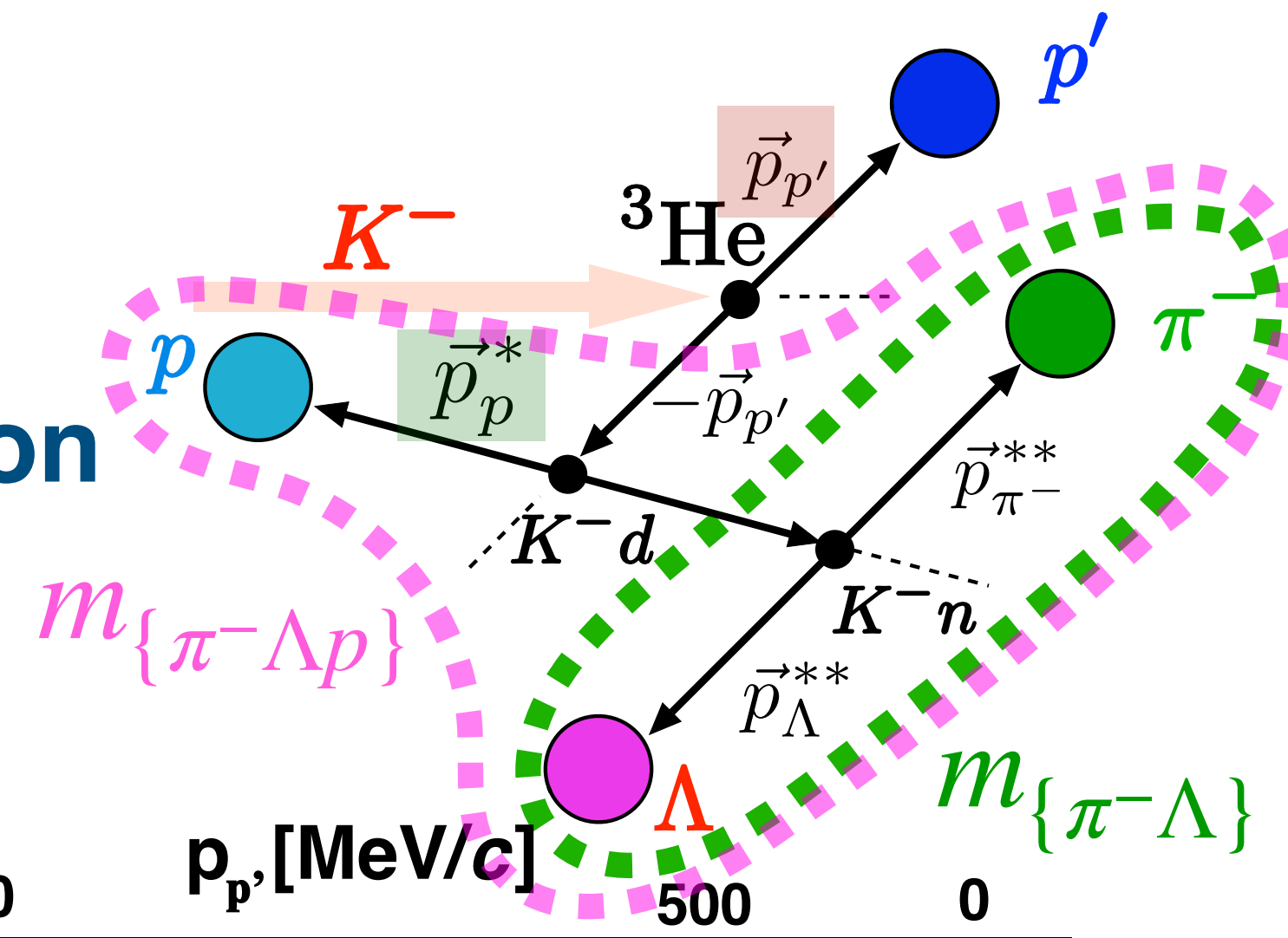

$K^- + {}^3\text{He} \rightarrow (\pi^- \Lambda p) + p$ reaction

consistent with $K^- + {}^3\text{He} \rightarrow \Lambda p n$ reaction
branch seems to be order bigger

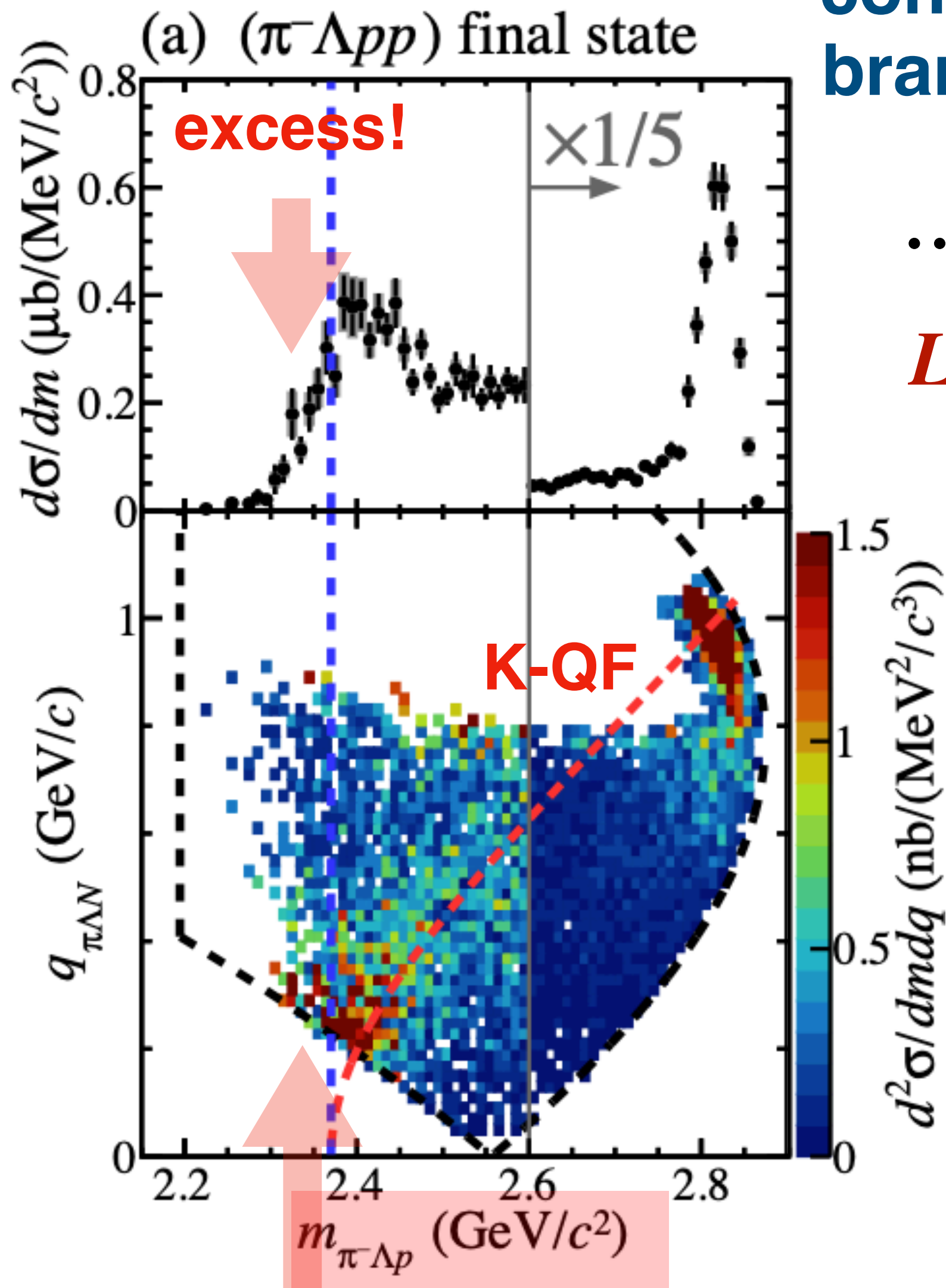
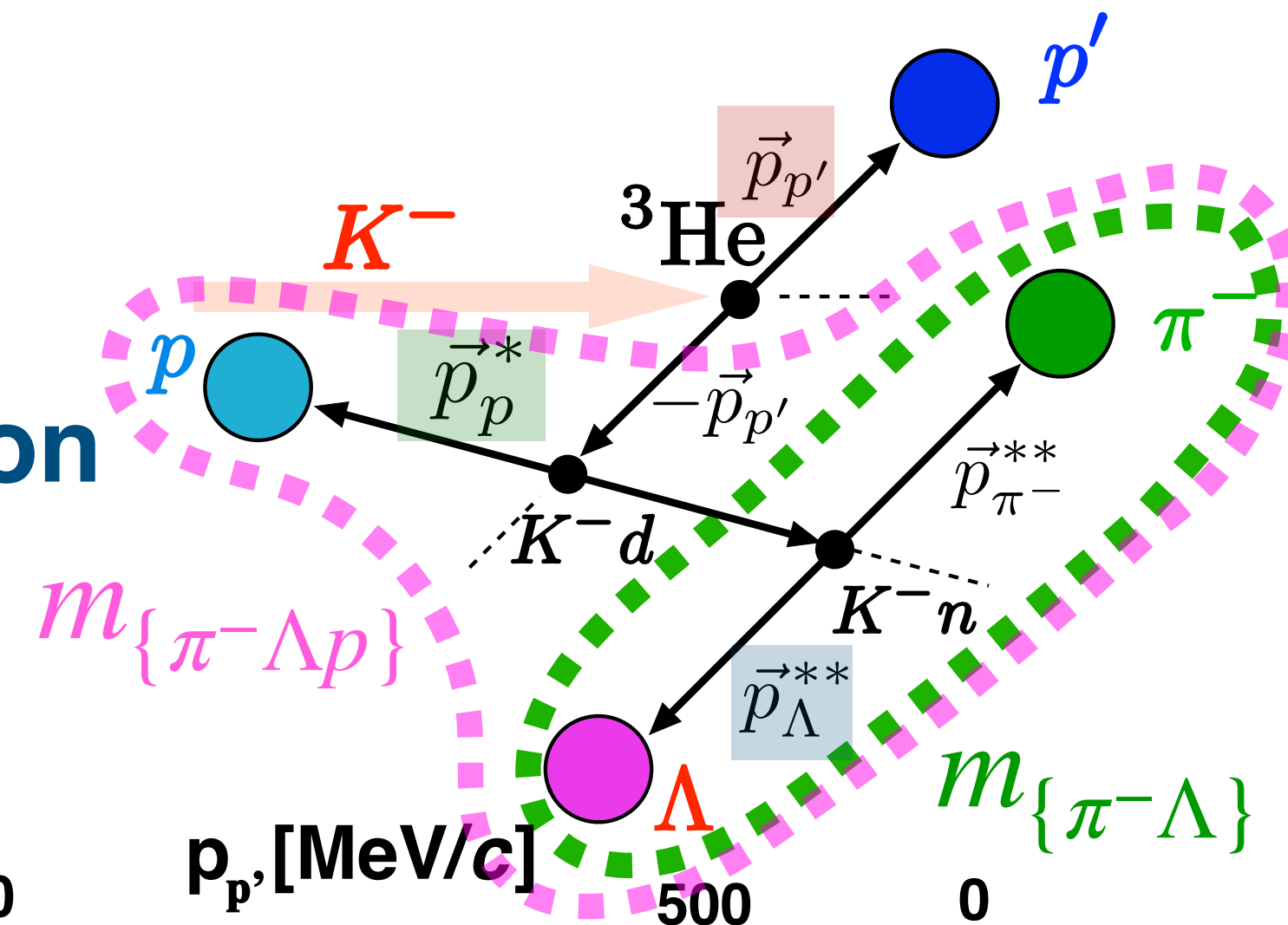

... *excess* is not easy to see ...

Let's normalize event density by 4-body phase space

The normalization by 4-body phase space, i.e., final-state-density

$$\rho_{(\pi^- \Lambda p p')} = \frac{d^2 N_{(\pi^- \Lambda p p')}}{dm_{\{\pi^- \Lambda p\}} dm_{\{\pi^- \Lambda\}}}$$

$$\propto p_{p'} \times p_p^* \times p_\Lambda^{**}$$

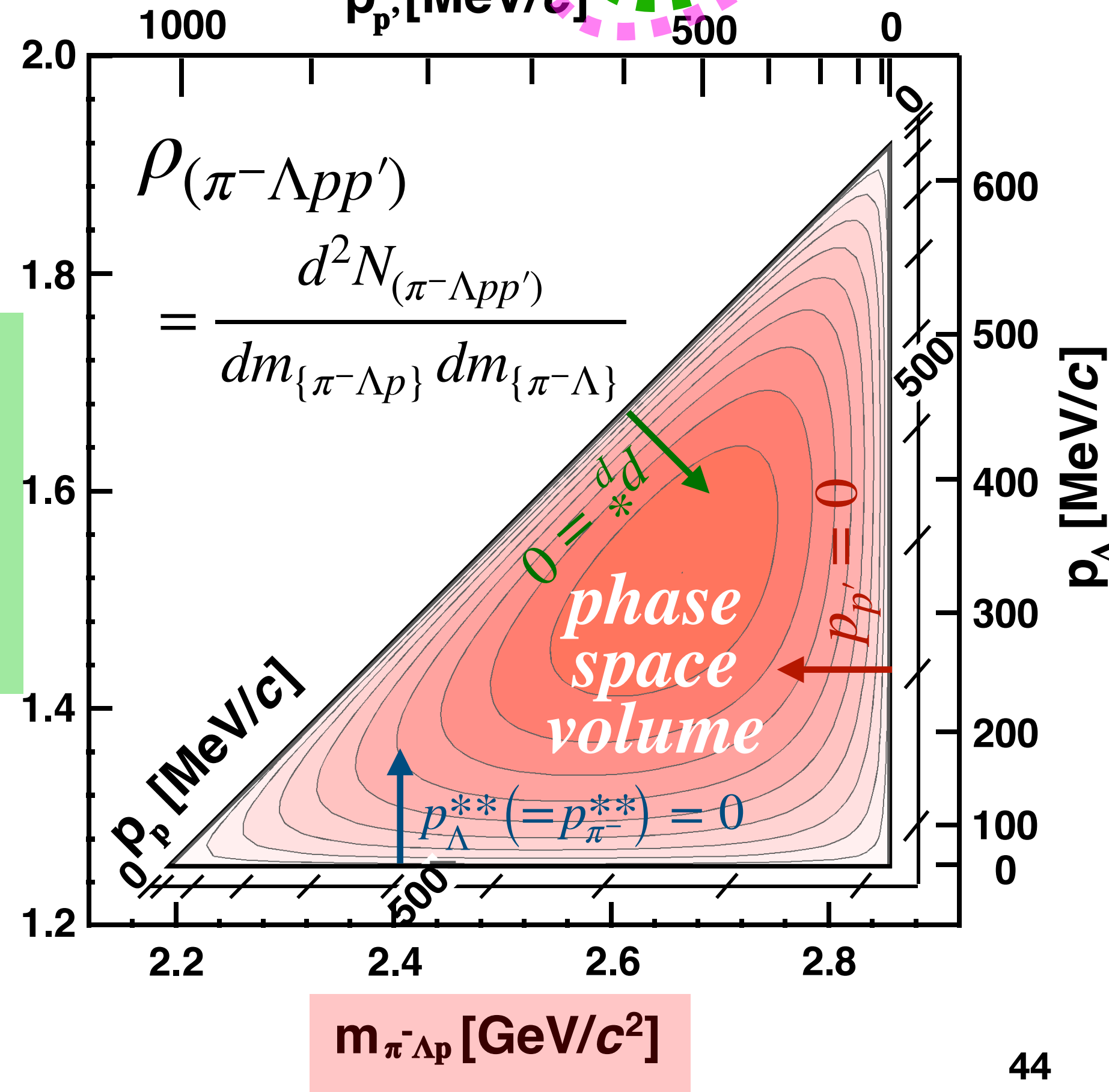

... analyzed by T. Yamaga

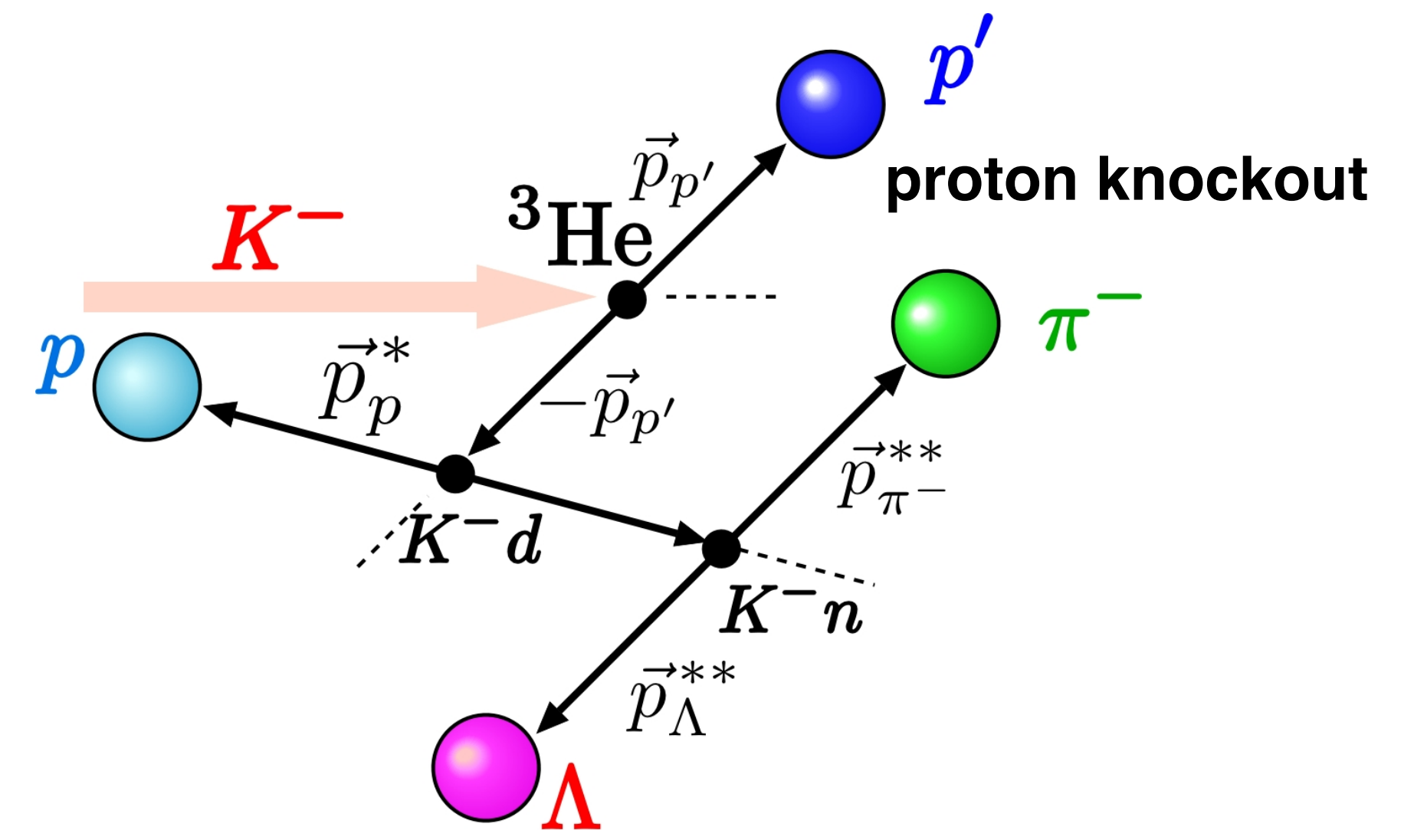
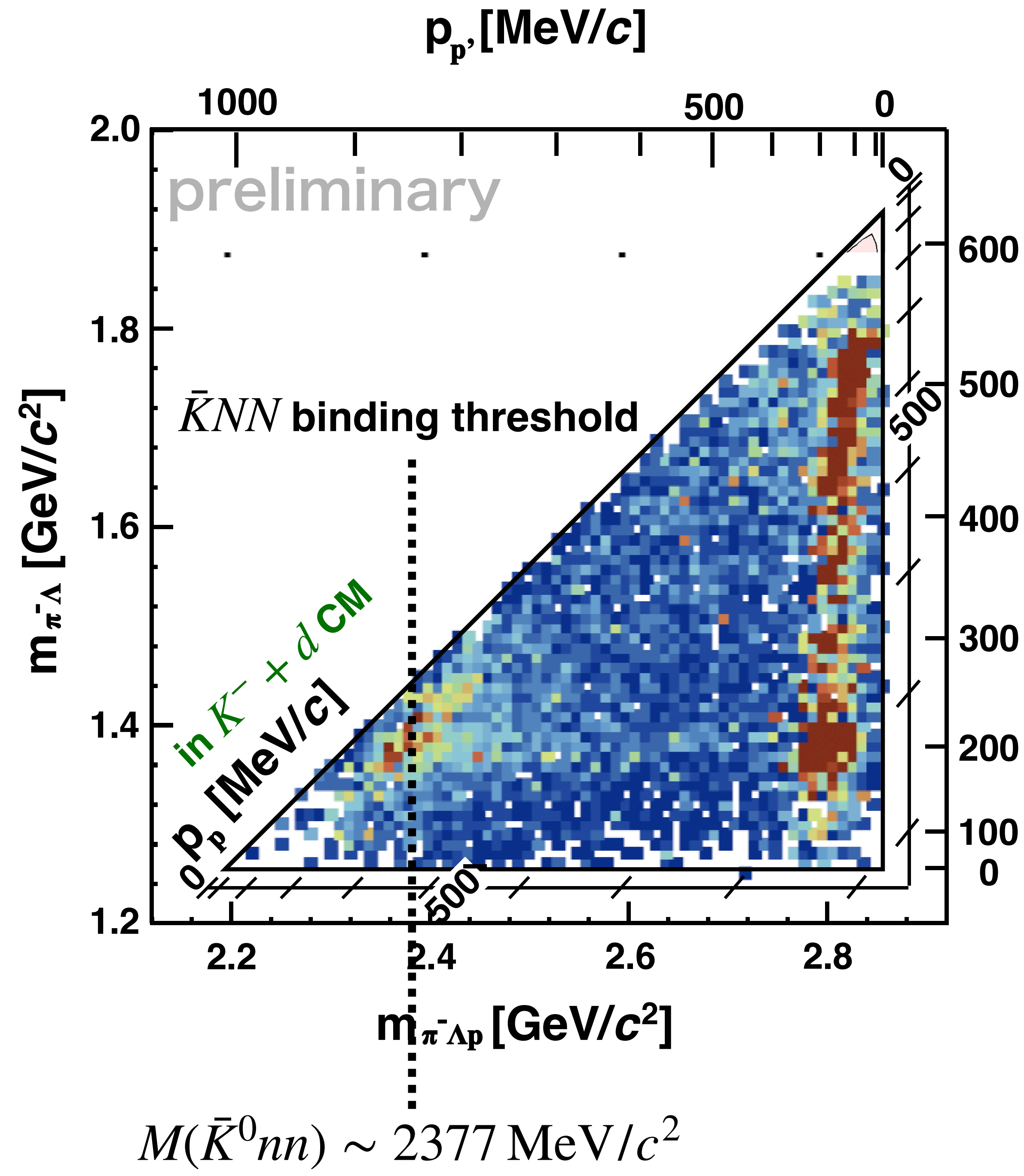

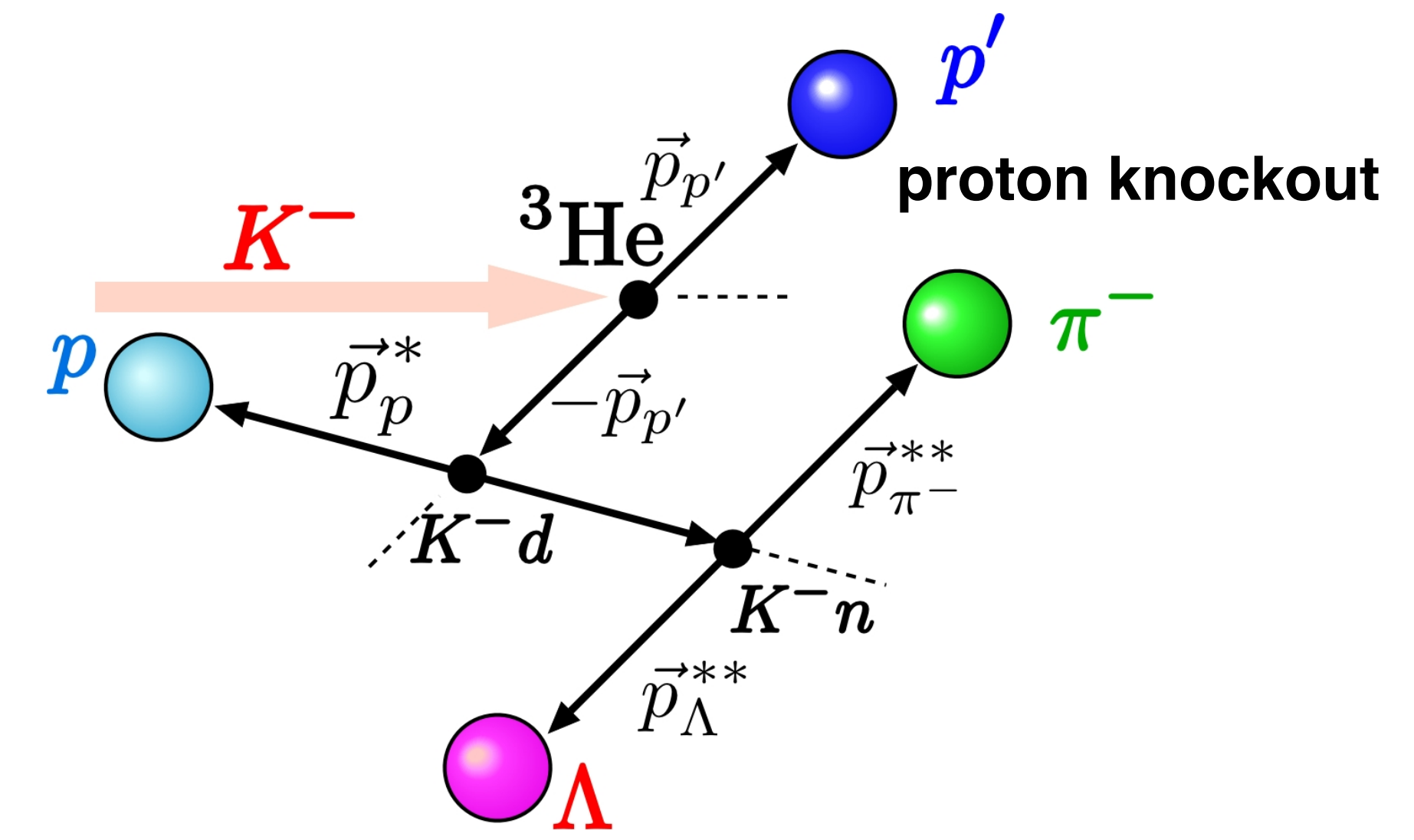
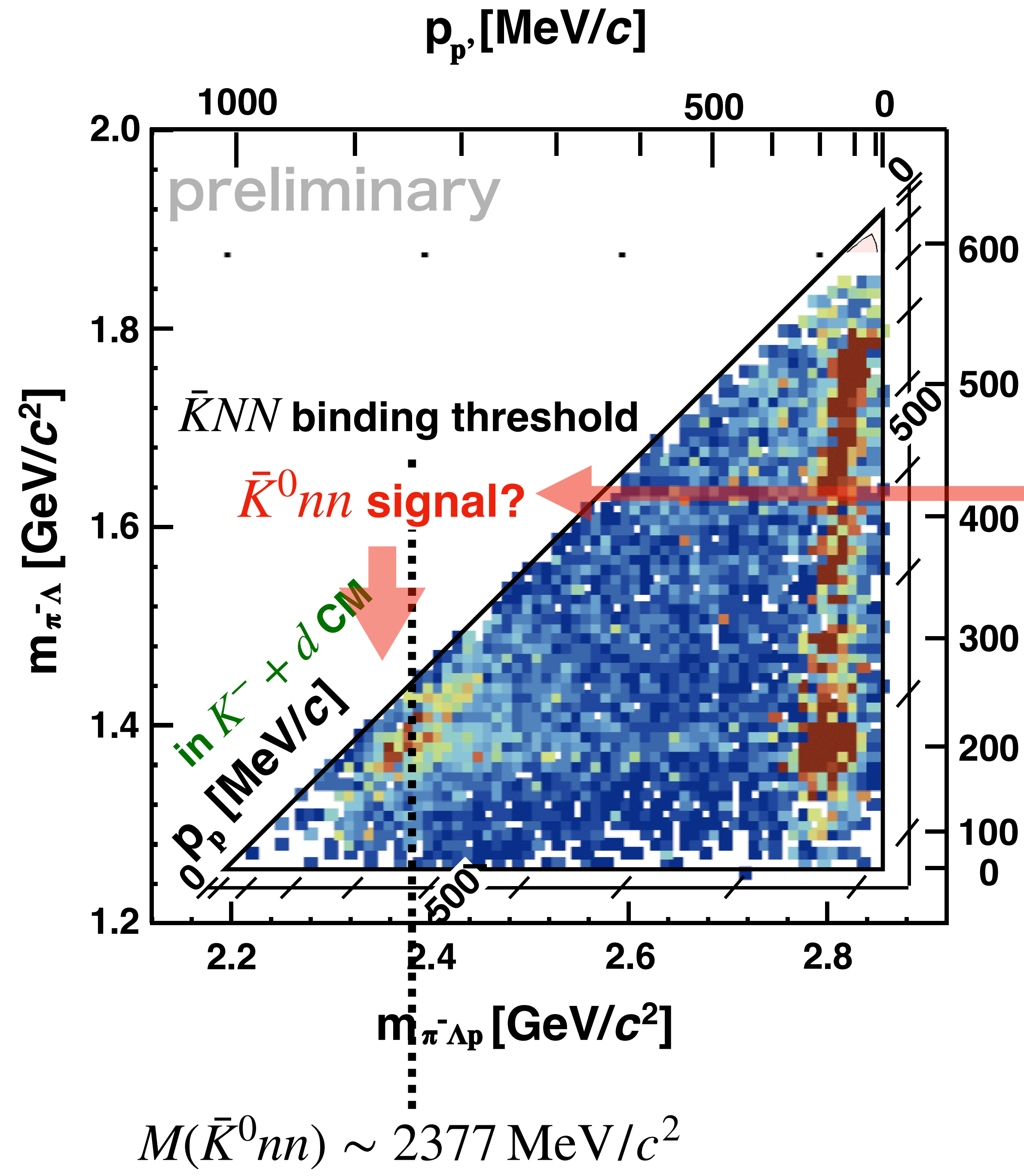

$K^0 nn$ signal-like event concentration below \bar{K} -bound threshold is seen?
 — twice more data become available in April —

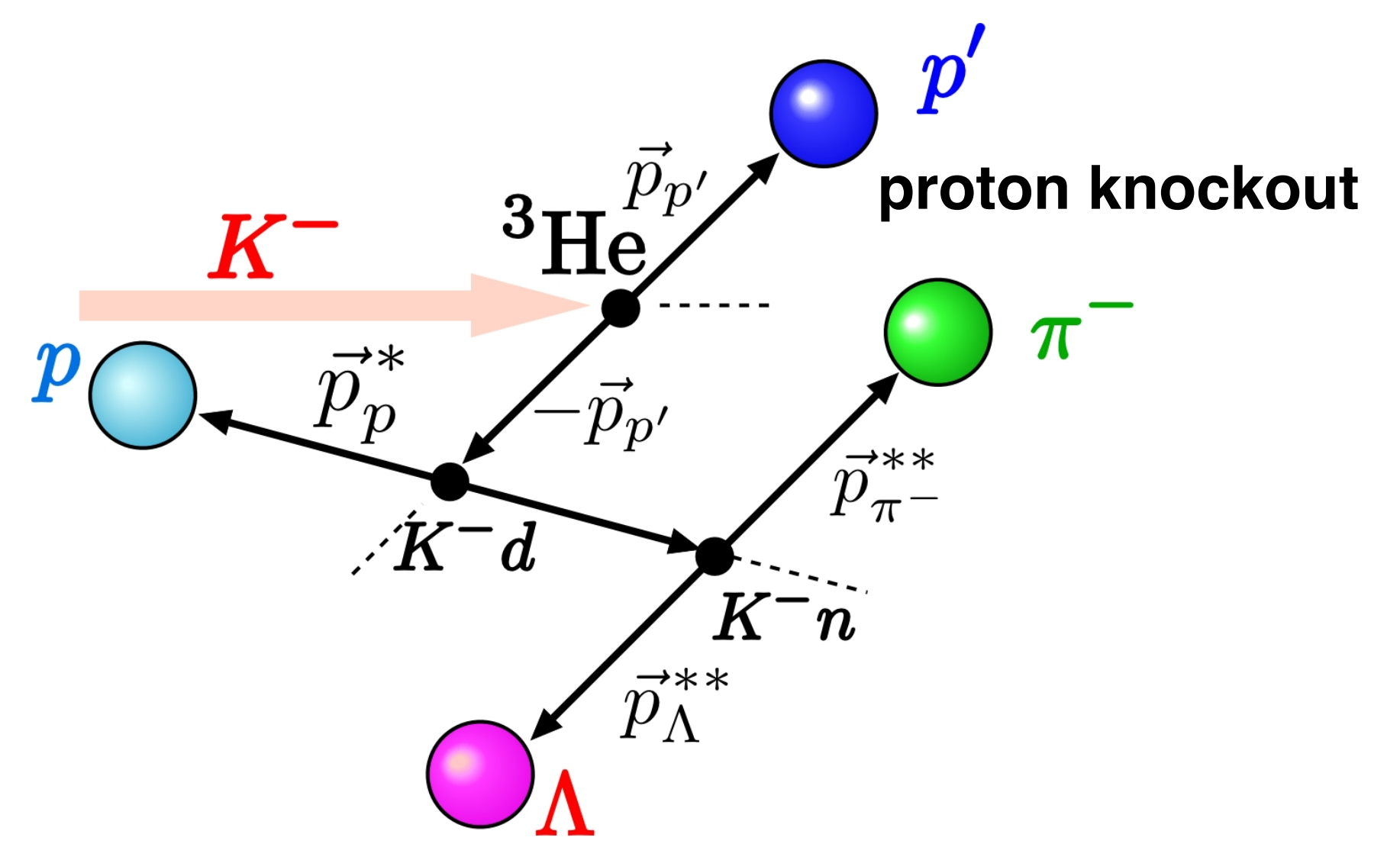
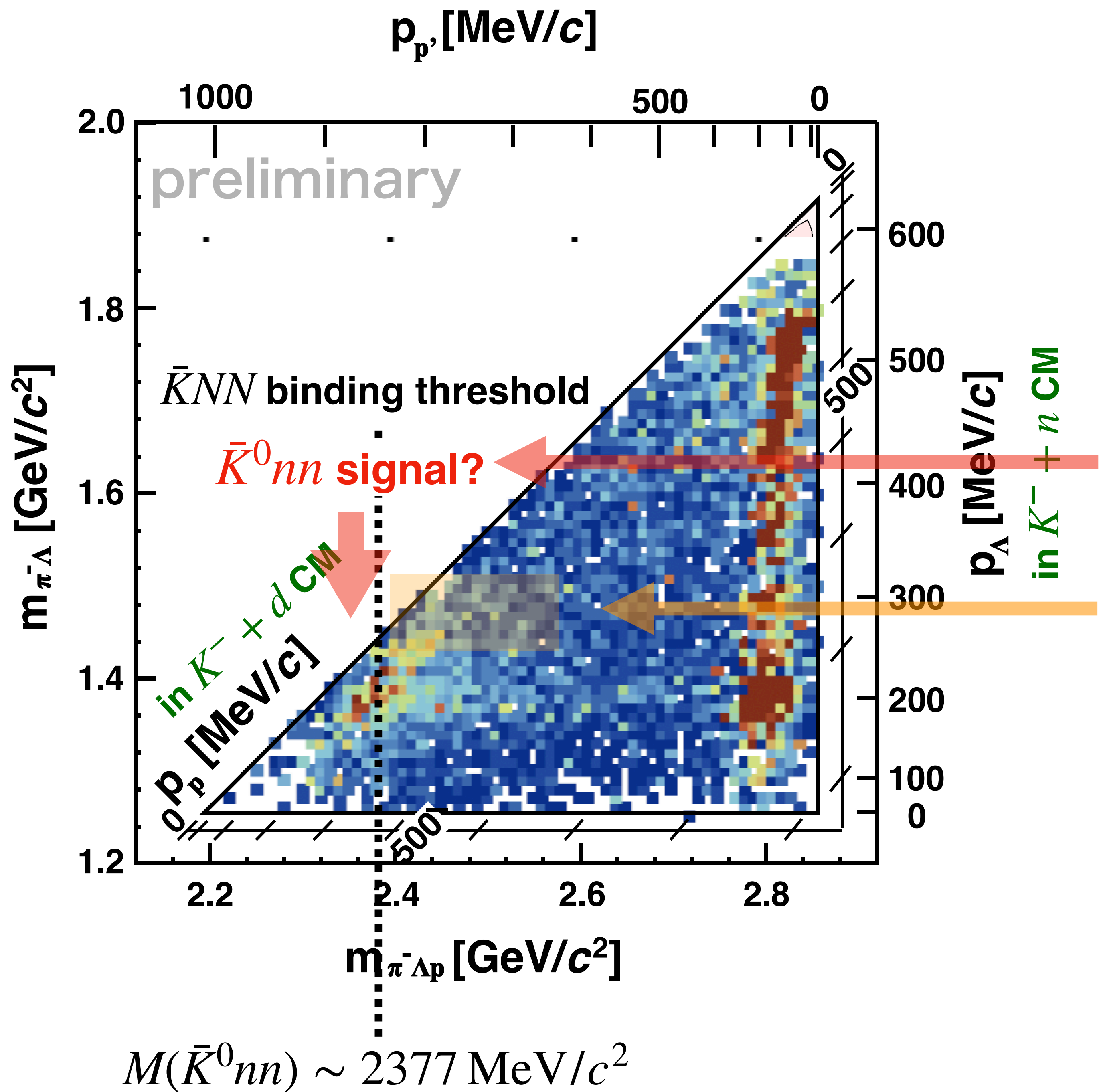

$\bar{K}^0 nn$ signal-like event concentration below \bar{K} -bound threshold is seen?
 — twice more data become available in April —
 QF-K induced reaction?

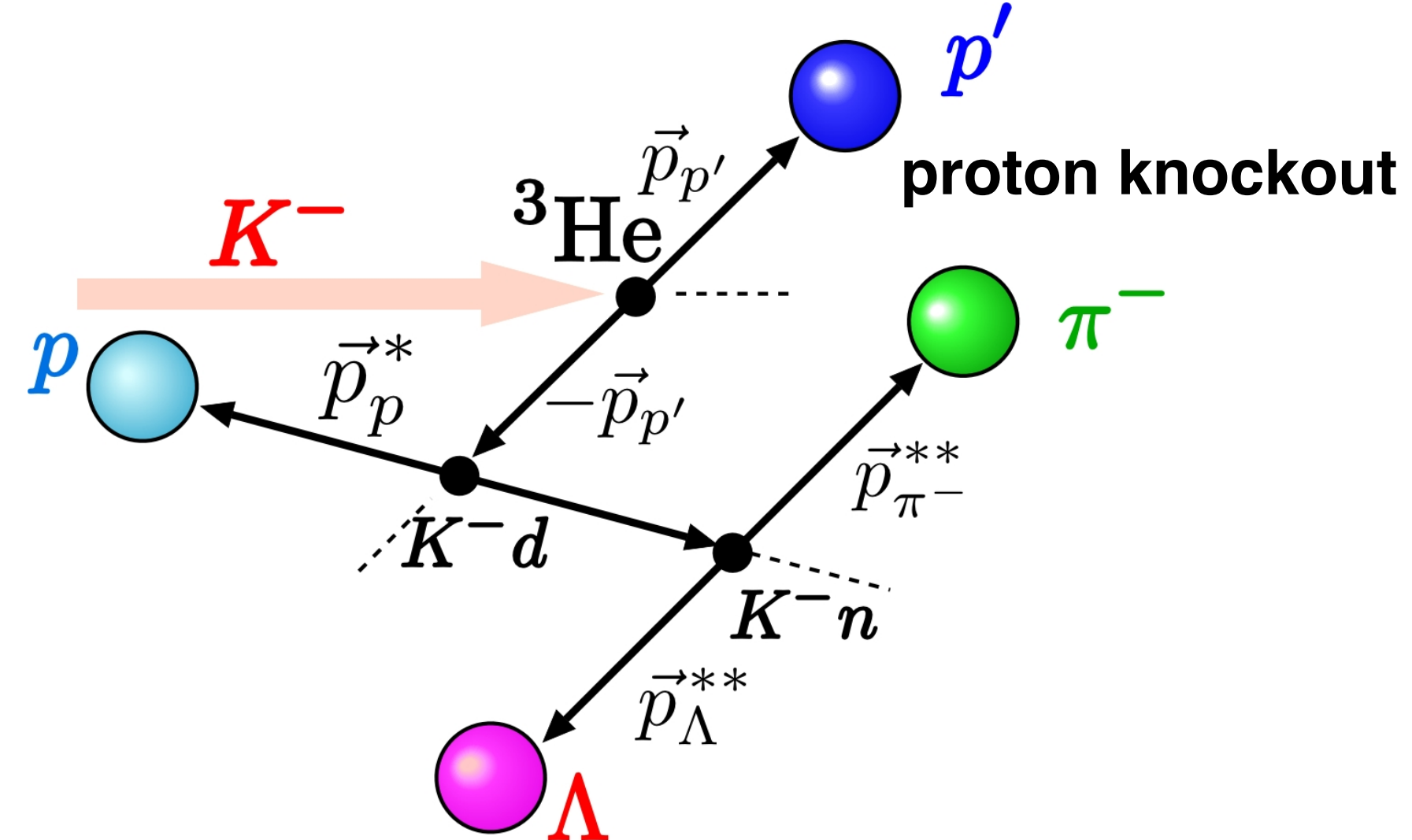
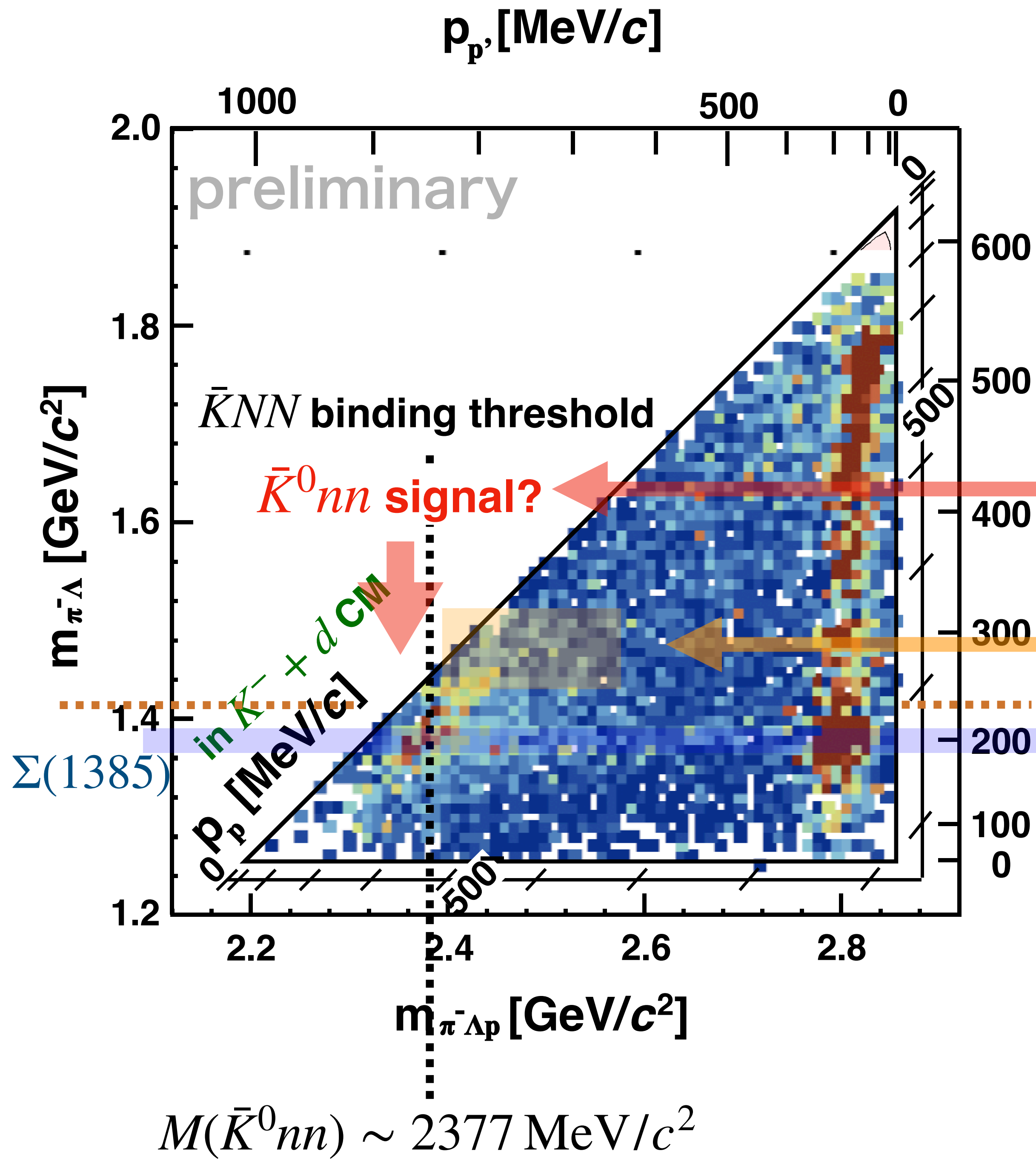

$\bar{K}^0 nn$ signal-like event concentration below \bar{K} -bound threshold is seen?
 — twice more data become available in April —

QF-K induced reaction?

$\bar{K}N$ binding threshold

$\Sigma(1385)$ contribution is not negligible compared to $(\Lambda p) + n$ final state.

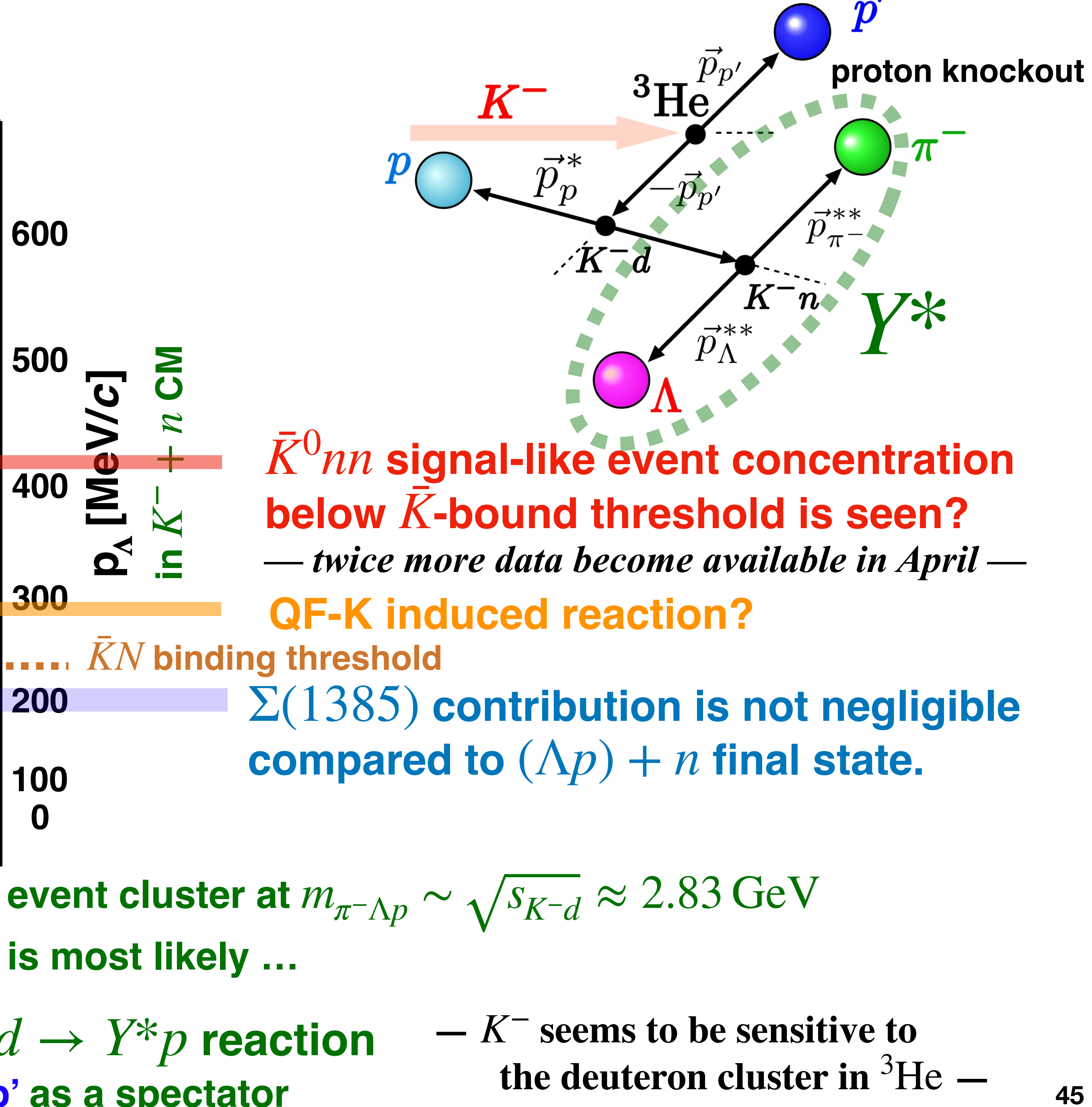
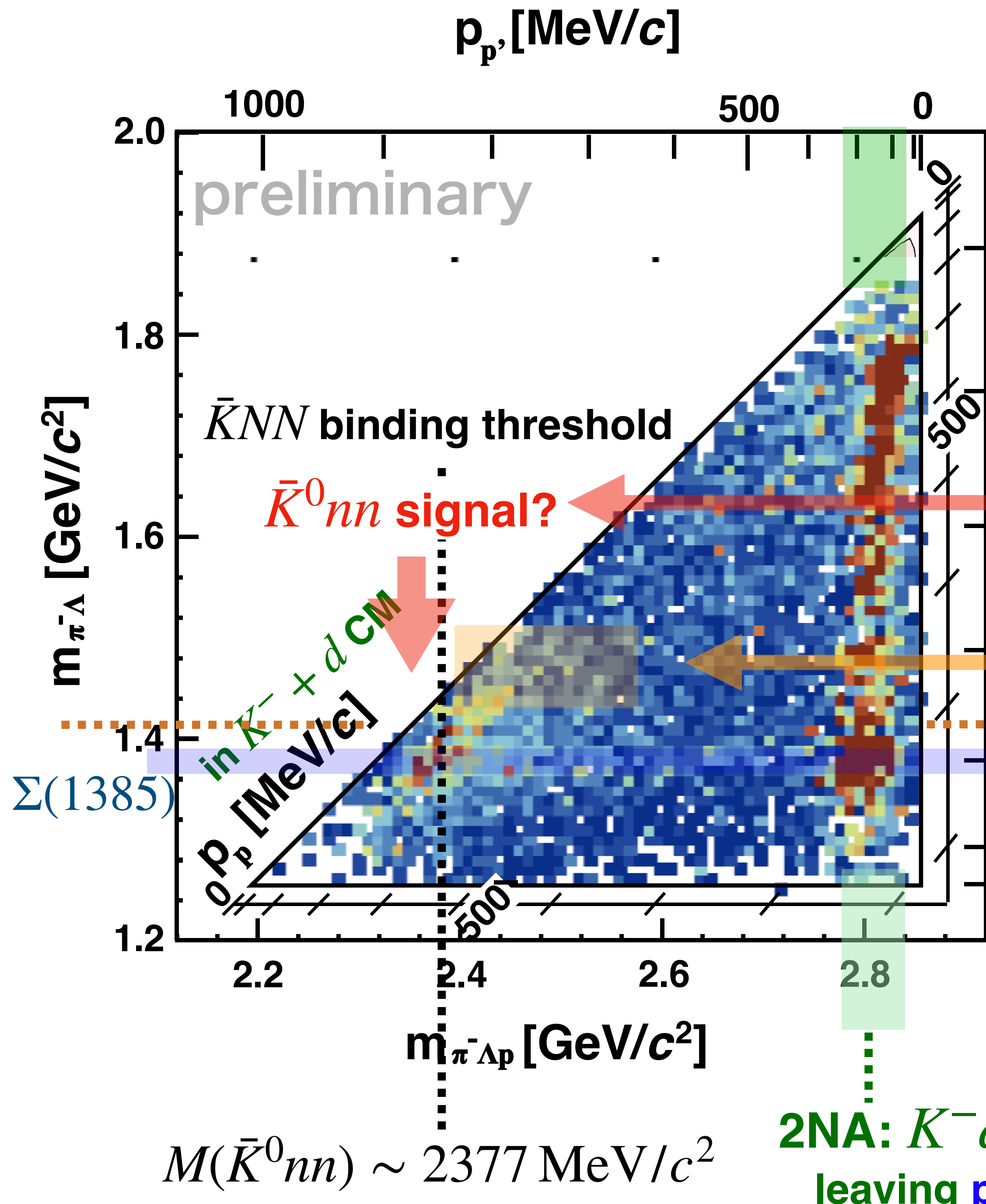

What we learned for kaonic nuclear bound state:

- K^-pp $\left(I(J^P) = \frac{1}{2}(0^- \text{ or } 1^-?) \right)$ identified in $\bar{K}NN \rightarrow \Lambda p$ analysis (2N_{KA})
Phys. Lett. B789, 620-625 (2019)
Phys. Rev. C102, 044002 (2020)
“ K^-pp ” $\rightarrow \Lambda p$ decay requires the isospin to be $I_{\bar{K}NN} = 1/2$.
- $\bar{K}NN \rightarrow \pi Y p$ decay dominance (1N_{KA} \gg 2N_{KA}) $Br_{\pi Y p} > 10 \times Br_{\Lambda p}$
- K^-pp isospin partner, $\bar{K}^0 nn$, would be identified in $\pi^- \Lambda p$ decay

$\bar{K}N$ interaction is also strong in $I_{\bar{K}N} = 1$, at least for absorption

<https://arxiv.org/abs/2404.01773> ... T. Yamaga



- $\bar{K}NNN$ $\left(I(J^P) = 0 \left(\frac{1}{2}^- \right) \right)$ identified in $K^-ppn \rightarrow \Lambda d$ *one more data available in April*
Spin-Parity automatically FIXED!

Preliminary analysis \rightarrow Three nucleon bound state!
Higher statistics is needed to be conclusive... T. Hashimoto