



Triangle Singularity Plus Isospin breaking

Jia-Jun Wu (UCAS)

Collaborators: Qi Huang, Zixuan Ma, Ronggang Ping, Jun He,
Hongxia Huang

PRD 110 (2024) 3, 034018 [arXiv: 2405.11127 \[hep-ph\]](https://arxiv.org/abs/2405.11127)

FB23 Sep-25-2024 IHEP, Beijing

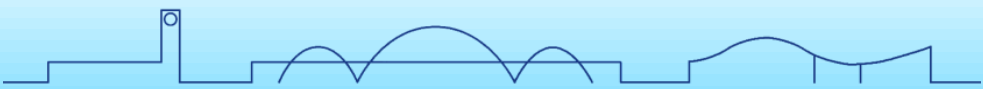

中国科学院大学
University of Chinese Academy of Sciences



Content

- What is Triangle Singularity?
- TS + Iso-spin breaking
- TS in $J/\psi \rightarrow \bar{\Lambda}\Lambda\pi$
- Summary

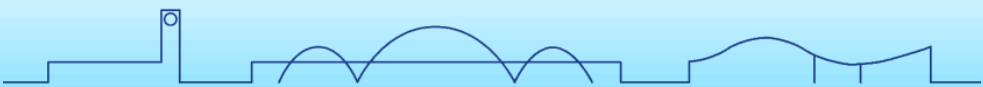

What is Triangle Singularity?

Happened Process

- (1) All particles are on mass-shell;
- (2) Particle 3 catch up particle 2.

L. D. Landau, *NP* 13, 181 (1960)
 S. Coleman, R.E. Norton, *Nuovo Cim.* 38, 438 (1965)
 R. Karplus, C.M. Sommerfield, E.H. Wichmann, *PR* 111, 1187 (1958).
 J.D. Bjorken, Ph.D. Thesis, Stanford University, Stanford, CA, USA, (1959).
 C. Schmid, *PR* 154, 1363 (1967)

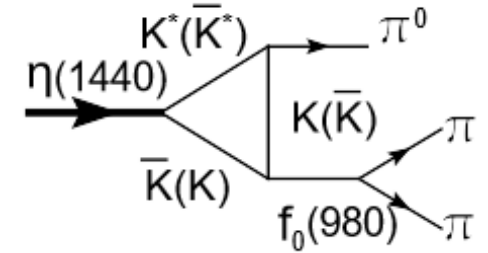
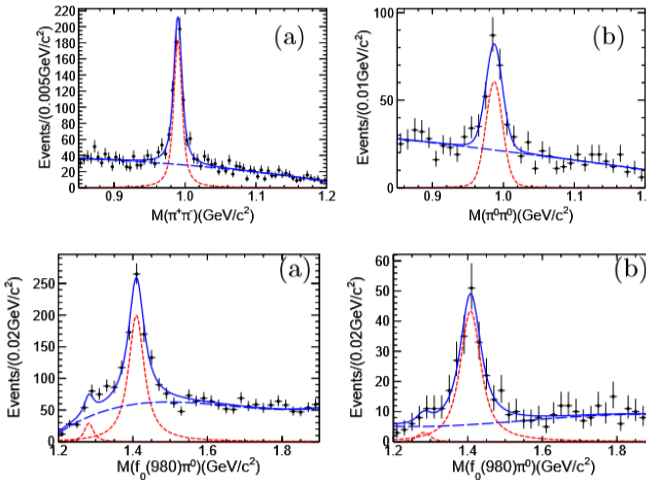
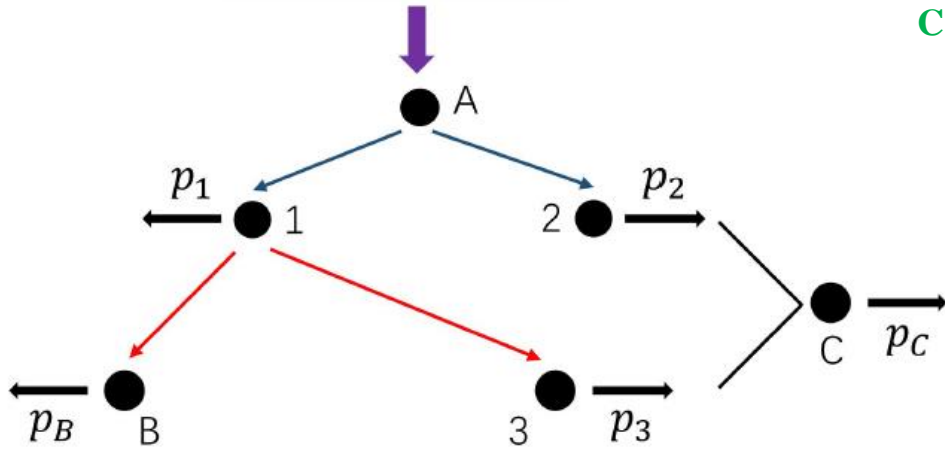
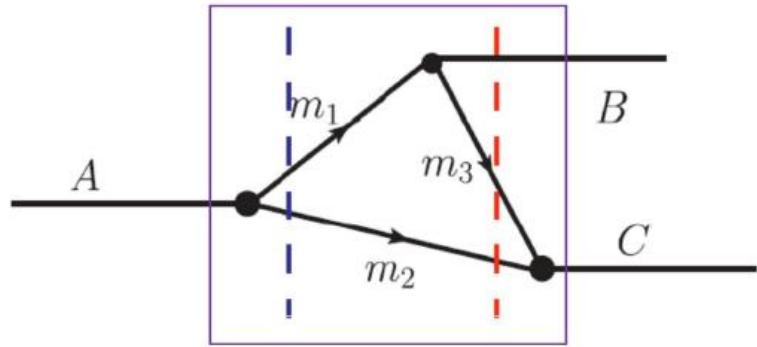

BESIII collaboration,
PRL 108, 182001(2012)
 Wu, Liu, Zhao, Zou
PRL, 108, 081803 (2012)



Why Triangle Singularity interesting ?

Guo, Liu, Sakai PPNP 112, 103757 (2020)

Structures	Processes	Loops	I/F	Refs.
2.1 GeV [141]	$\gamma p^+ \rightarrow N^*(2030) \rightarrow K^+ \Lambda(1405)$	$K^* \Sigma \pi$	I	[142]
2.1 GeV	$\pi^- p^+ \rightarrow K^0 \Lambda(1405), pp \rightarrow p K^+ \Lambda(1405)$	$K^* \Sigma \pi$	I	[143]
1.88 GeV	$\Lambda_c^+ \rightarrow \pi^+ \pi^0 \pi \Sigma$	$\bar{K}^* N \bar{K}$	I	[144, 145] ^a
$N(1700)$ [10]	$N(1700) \rightarrow \pi \Delta$	$\rho N \pi$	I	[146]
$N(1875)$ [10]	$N(1875) \rightarrow \pi N(1535)$	$\Sigma^* K \Lambda$	I	[147]
$\Delta(1700)$ [148-150]	$\gamma p \rightarrow \Delta(1700) \rightarrow \pi N(1535) \rightarrow p \pi^0 \eta$	$\Delta \eta p$	I	[151]
2.2 GeV [152]	$\Lambda_c^+ \rightarrow \pi^0 \phi p$	$\Sigma^* K^* \Lambda$	F	[153]
1.66 GeV [154, 155]	$\Lambda_c^+ \rightarrow \pi^+ K^- p$	$a_0 \Delta \eta, \Sigma^* \eta \Lambda$	F	[156]
$P_c(4450)$ [35]	$\Lambda_b^0 \rightarrow K^- J/\psi p$	$\Lambda(1890) \chi_{c1} P$	F	[157-160] ^b
		$N(1900) \chi_{c1} P$	F	[159]
peaks relevant for P_c	$\Lambda_b^0 \rightarrow K^- J/\psi p$	$D_{s1} \Lambda_c^+ \bar{D}^{(*)}$	F	[36, 158]

Structures	Processes	Loops	I/F	Refs.
$\rho(1480)$ [78, 79]	$\pi^- p \rightarrow \phi \pi^0 n$	$K^* \bar{K} K$	I	[80, 81]
$\eta(1405/1475)$ [82-86]	$\eta(1405/1475) \rightarrow \pi f_0$	$K^* \bar{K} K$	I	[87-91] ^{a,b}
$f_1(1420)$ [92]	$f_1(1285) \rightarrow \pi a_0/\pi f_0$	$K^* \bar{K} K$	I	[89, 93-95] ^b
$a_1(1420)$ [96, 97]	$a_1(1260) \rightarrow f_0 \pi \rightarrow 3\pi$	$K^* \bar{K} K$	I	[97-99]
1.4 GeV [100]	$J/\psi \rightarrow \phi \pi^0 \eta/\phi \pi^0 \pi^0$	$K^* \bar{K} K$	I	[101] ^b
1.42 GeV	$B^- \rightarrow D^{*0} \pi^- f_0(a_0), \tau \rightarrow \nu_\tau \pi^- f_0(a_0)$	$K^* \bar{K} K$	I	[102, 103]
	$D_s^+ \rightarrow \pi^+ \pi^0 f_0(a_0), B_s^0 \rightarrow J/\psi \pi^0 f_0(a_0)$	$K^* \bar{K} K$	I	[104, 105]
$f_2(1810)$ [10]	$f_2(1640) \rightarrow \pi \pi \rho$	$K^* \bar{K} K$	I	[106]
1.65 GeV	$\tau \rightarrow \nu_\tau \pi^- f_1(1285)$	$K^* \bar{K} K$	I	[107]
1515 MeV	$J/\psi \rightarrow K^+ K^- f_0(a_0)$	$\phi \bar{K} K$	I	[108]
2.85 GeV, 3.0 GeV	$B^- \rightarrow K^- \pi^- D_{s1}^0/K^- \pi^- D_{s1}$	$K^{*0} D^{(*)0} K^+$	I	[109, 110]
5.78 GeV	$B_s^+ \rightarrow \pi^0 \pi^+ B_s^0$	$\bar{K}^{*0} B^+ K$	F	[111]
[4.01, 4.02] GeV	$[D^{*0} D^{*0}] \rightarrow \gamma X$	$D^{*0} D^{*0} D^0$	I	[112]
4015 MeV	$e^+ e^- \rightarrow \gamma X$	$D^{*0} D^{*0} D^0$	I	[113, 114]
4015 MeV	$B \rightarrow K X \pi, pp/pp \rightarrow X \pi + \text{anything}$	$D^{*0} D^{*0} D^0$	I	[115, 116]
$\Upsilon(11020)$ [117, 118]	$e^+ e^- \rightarrow Z_0 \pi$	$B_1(5721) B B^+$	I	[119, 120]
3.73 GeV	$X \rightarrow \pi^0 \pi^+ \pi^-$	$D^{*0} D^0 D^0$	F	[121]
[4.22, 4.24] GeV	$e^+ e^- \rightarrow \gamma J/\psi \phi/\pi^0 J/\psi \eta$	$D_{s0(a1)}^+ D_s^{(*)} D_s^{(*)}$	F	[122]
[4.08, 4.09] GeV	$e^+ e^- \rightarrow \pi^0 J/\psi \eta$	$D_{s0(a1)}^+ D_s^{(*)} D_s^{(*)}$	F	[122]
$Z_c(3900)$ [31, 32]	$e^+ e^- \rightarrow J/\psi \pi^+ \pi^-$	$D_1 D^* D$	F	[119, 123-127] ^c
		$D_{s1}^*(2400) D^* D$	F	[128, 129]
$Z_c(4020, 4030)$ [33, 130]	$e^+ e^- \rightarrow \pi^+ \pi^- h_c(\psi)$	$D_{1(2)} \bar{D}^{(*)} D^{(*)}$	F	[125]
$X(4700)$ [131, 132]	$B^+ \rightarrow K^+ J/\psi \phi$	$K_1(1650) \psi \phi$	F	[133]
$Z_c(4430)$ [30, 134]	$\bar{B}^0 \rightarrow K^- \pi^+ J/\psi$	$\bar{K}^{*0} \psi(4260) \pi^+$	F	[135]
$Z_c(4200)$ [136, 137]	$\bar{B}^0 \rightarrow K^- \pi^+ \psi(2S)$	$\bar{K}_1^* \psi(3770) \pi^+$	F	[135]
	$\Lambda_b^0 \rightarrow p \pi^- J/\psi$	$N^* \psi(3770) \pi^-$	F	[135]
$X(4050)^{\pm}$ [138]	$\bar{B}^0 \rightarrow K^- \pi^+ \chi_{c1}$	$\bar{K}^{*0} X \pi^+$	F	[139]
$X(4250)^{\pm}$ [138]	$\bar{B}^0 \rightarrow K^- \pi^+ \chi_{c1}$	$\bar{K}_1^* \psi(3770) \pi^+$	F	[139]
$Z_b(10610)$ [34]	$e^+ e^- \rightarrow \Upsilon(1S) \pi^+ \pi^-$	$B_7^* \bar{B}^* B$	F	[128]

1. It is a pure kinematic effect \rightarrow Model independent
2. The effect of Loop \rightarrow Understand hadronic loop contribution
3. Provide a peak structure \rightarrow May mixing with resonance
4. Extract the nature of hadron \rightarrow Study the coupling at the energy point
5.

$$\pi p \rightarrow a_1(1420) \rightarrow f_0(980) \pi \rightarrow 3\pi$$

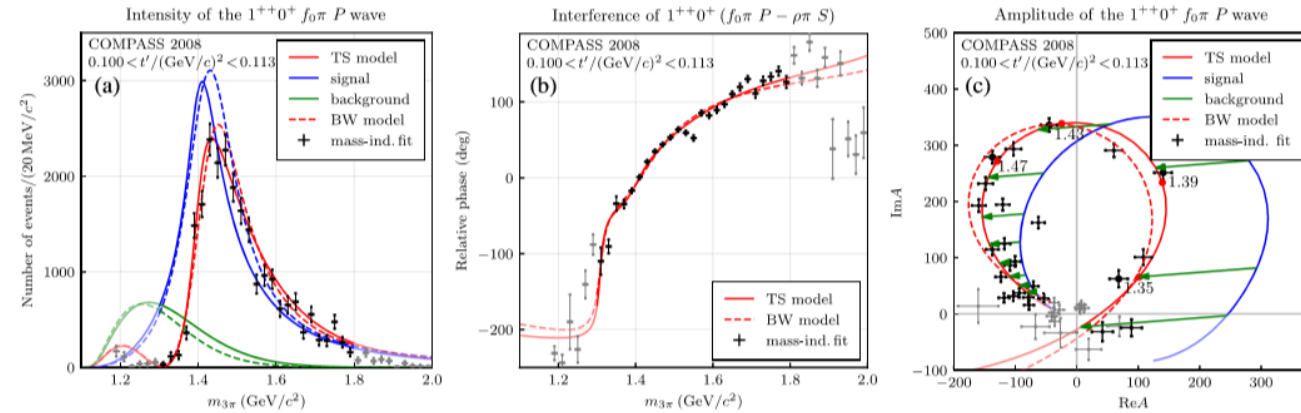

COMPASS Collaboration PRL 127, 082501 (2021)

Mikhasenko, Ketzer, Sarantsev PRD 91, 094015 (2015)

But not confirm yet ...



How to confirm Triangle Singularity?

1. Threshold

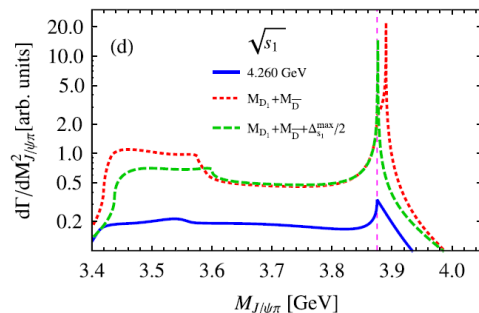
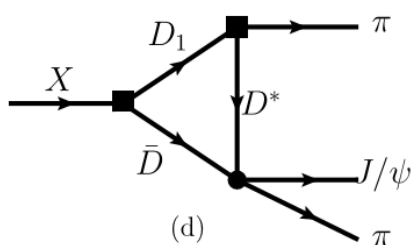

The corresponding values are listed in Table 1. The ATS peak will then stay close to the normal threshold, as illustrated in Fig. 4(d). In this sense, it would be difficult to distinguish the ATS peak from the pole structure in the invariant mass of the $J/\psi\pi$. We shall come back to the relevant issue later in this Section. It should be

X. H. Liu, M. Oka and Q. Zhao,
PLB 753, 297-302 (2016)

2. Width of the internal particle of the loop

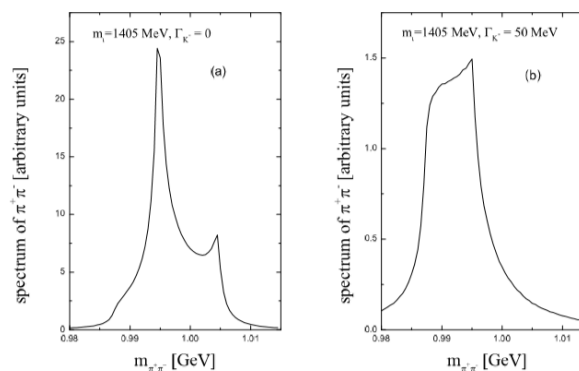
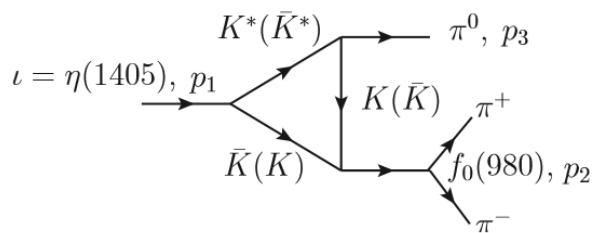

Achasov, Kozhevnikov, Sobolev IM,
Shestakov PRD 92 (2015) 3, 036003

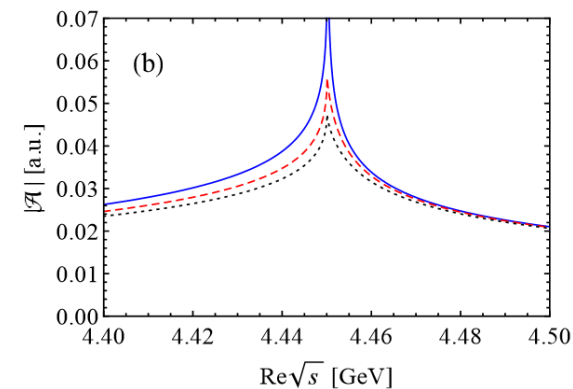

3. Unknown vertex

Guo, Meißner, Wang, Yang,
PRD92, 071502 (2015)

$$\begin{aligned} \Lambda_b &\rightarrow (c\bar{c})\Lambda^* \\ &\rightarrow (c\bar{c})\Lambda K^- \\ &\rightarrow J/\psi p K^- \end{aligned}$$

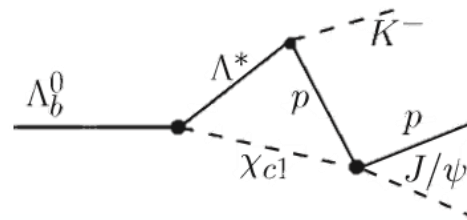

A Proposal ----- Problem

Qi Huang, Chaowei Sheng, Jia-Jun Wu PRD 103 (2021) 1, 016014

1. Threshold

Far away from $p\eta$ threshold. Singularity point is 1.563 GeV of $p\eta$ invariant mass.

2. Width of the internal particle of the loop

All narrow internal particles, J/ψ , p , η

3. Unknow vertex

All vertices are constrained from experimental data

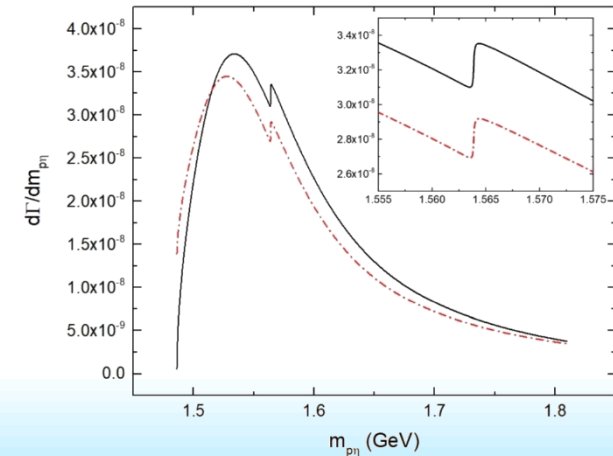
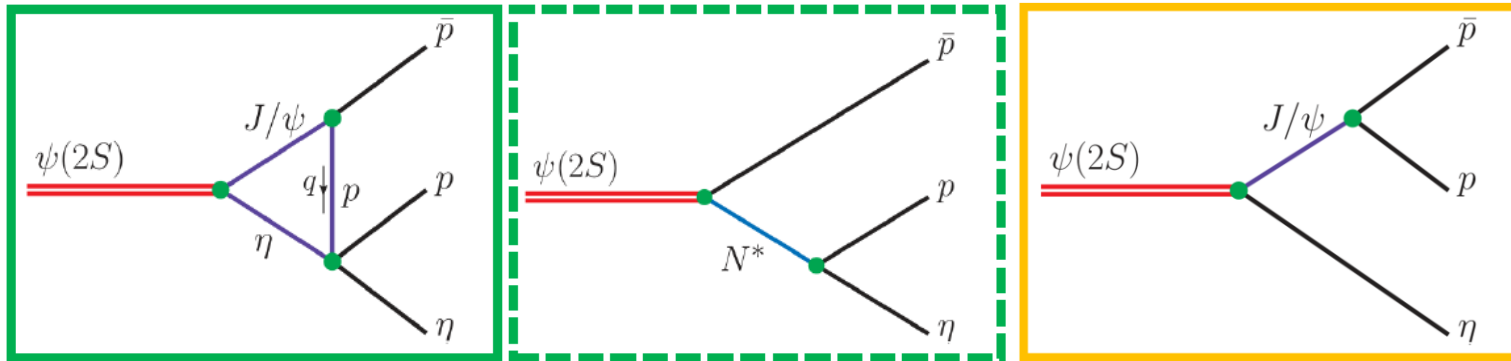
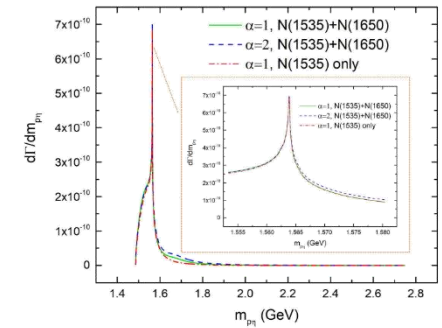
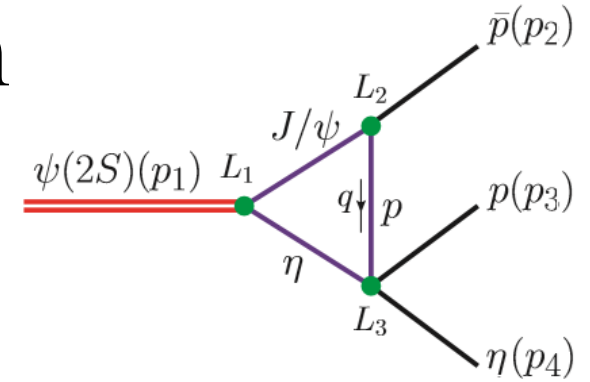

TS + Iso-spin breaking

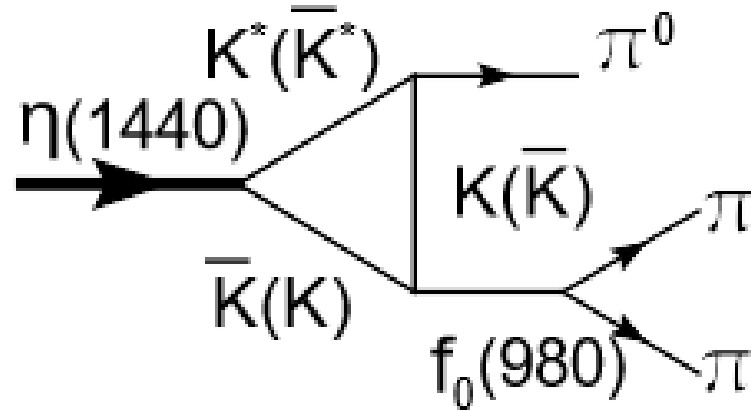
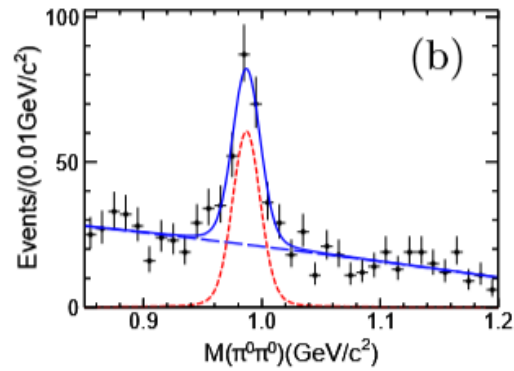
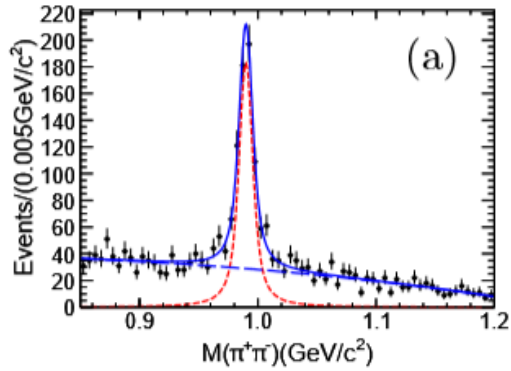

IDEA: Searching TS happen in the Iso-spin breaking process

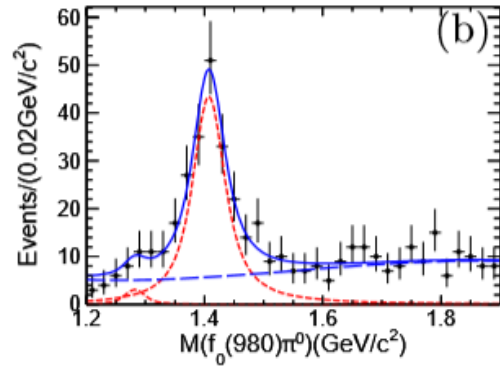
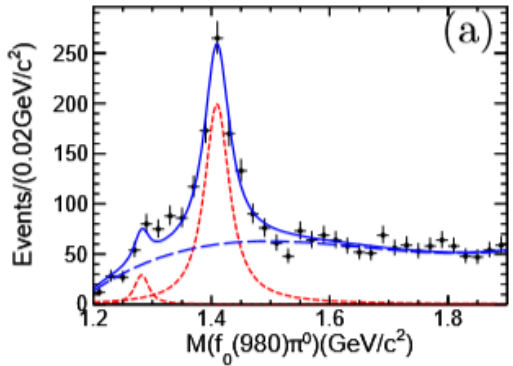

$$|M_+ - M_0|^2 \sim d\Gamma$$

No direct tree diagram obeying the isospin conservation

BESIII collaboration, PRL 108, 182001(2012)

Wu, Liu, Zhao, Zou, PRL, 108, 081803 (2012)



TS in $J/\psi \rightarrow \bar{\Lambda}\Lambda\pi$

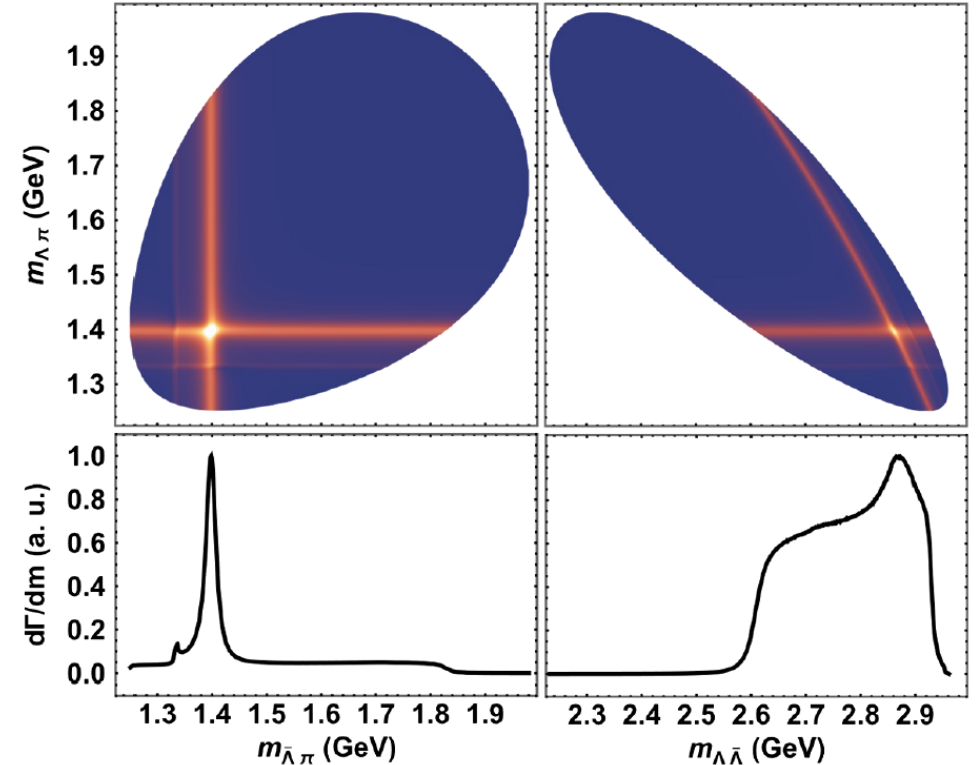
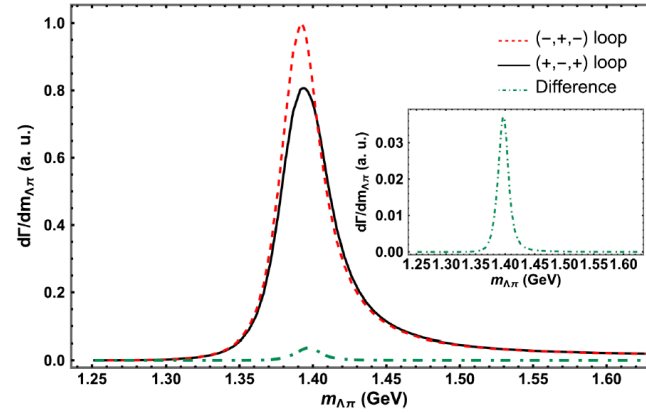
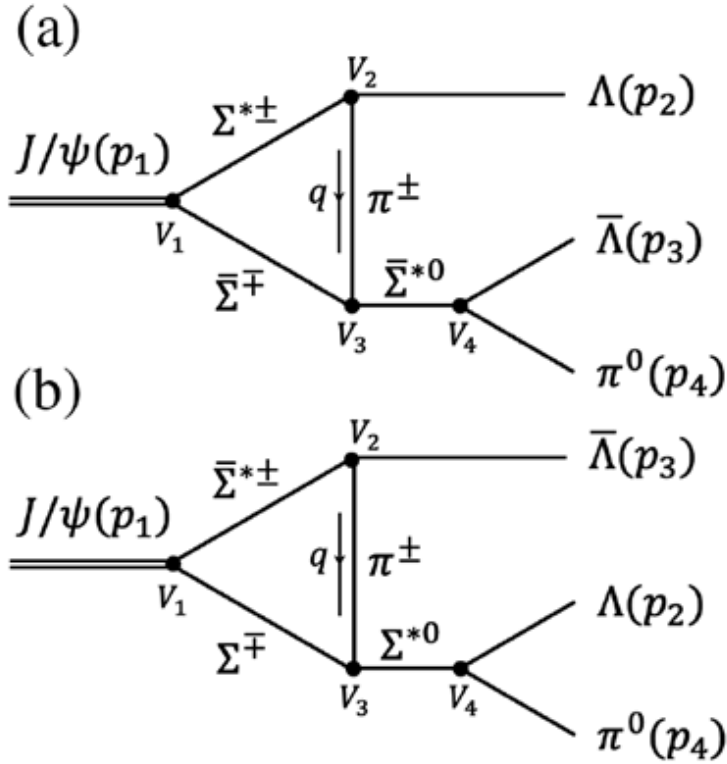

The mass difference considering here is:
 $\Sigma^- = 1197.45 \text{ MeV}$,
 $\Sigma^+ = 1189.37 \text{ MeV}$,
 and the positions of triangle singularities are 1409.09 MeV and 1400.73 MeV

$$\Sigma^{*\pm} = \Sigma^*(1620) \frac{1}{2}^-, \Sigma^*(1670) \frac{3}{2}^-$$

$$\Sigma^{*0} = \Sigma^*(1385) \frac{3}{2}^+, \Sigma^*(1380) \frac{1}{2}^-$$

Two questions:

1. Other choices
2. Backgrounds

TS in $J/\psi \rightarrow \bar{\Lambda}\Lambda\pi$

- Two questions:
1. Other choices
 2. Backgrounds

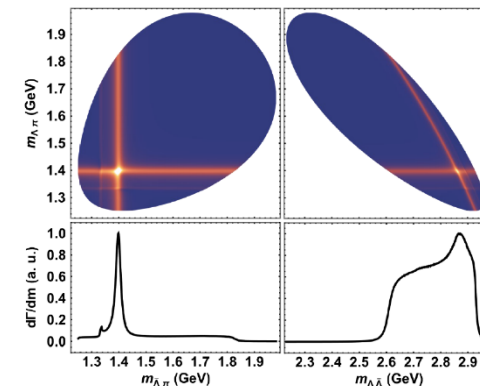
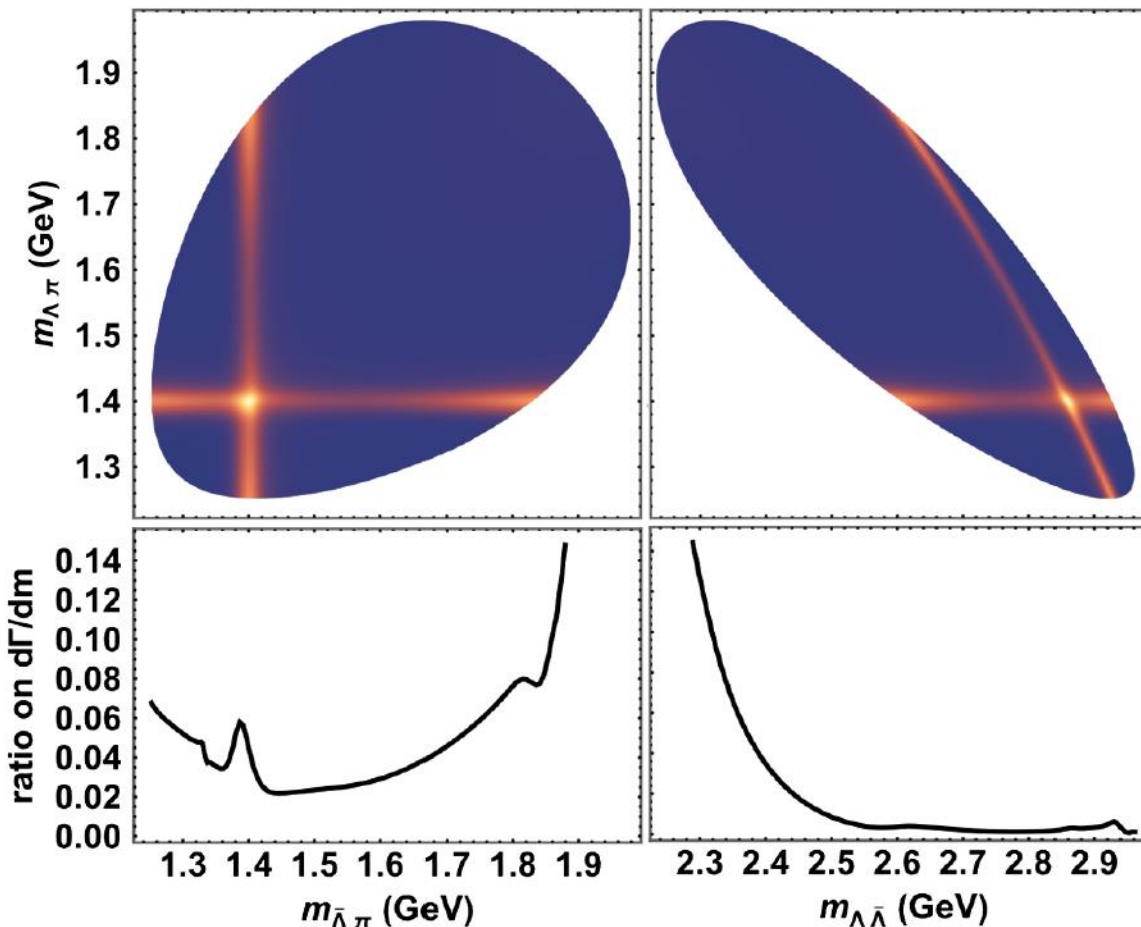
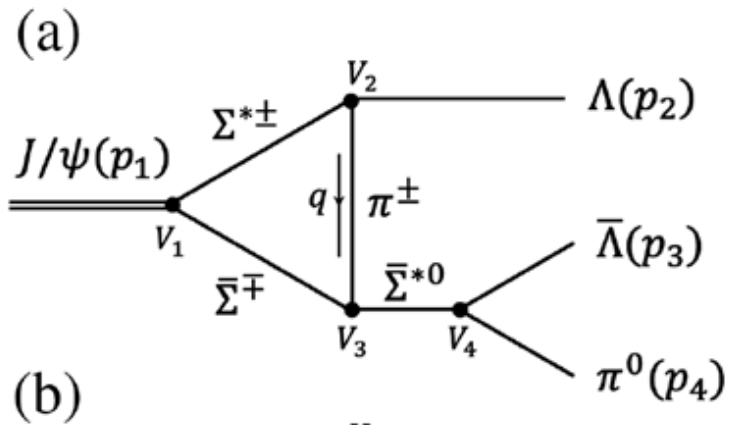

$$\Sigma^{*\pm} = \Sigma^*(1620) \frac{1}{2}^-, \Sigma^*(1670) \frac{3}{2}^-$$

$$\Sigma^{*0} = \Sigma^*(1385) \frac{3}{2}^+, \Sigma^*(1380) \frac{1}{2}^-$$

The particle wave between exchange π^{\mp} and Σ^{\pm} prefers the **S**-wave.



TS in $J/\psi \rightarrow \bar{\Lambda}\Lambda\pi$

- Two questions:
1. Other choices
 2. Backgrounds

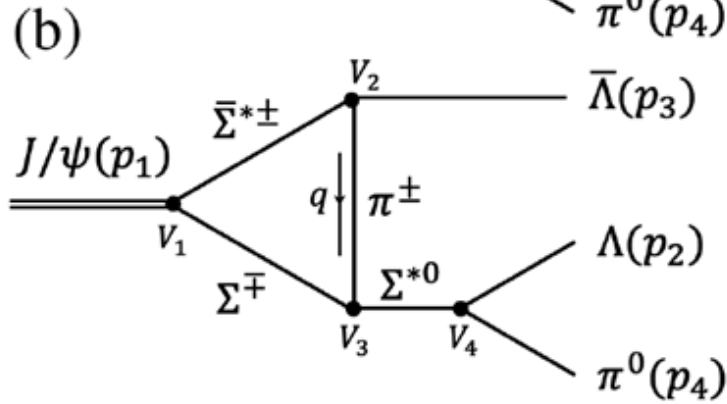
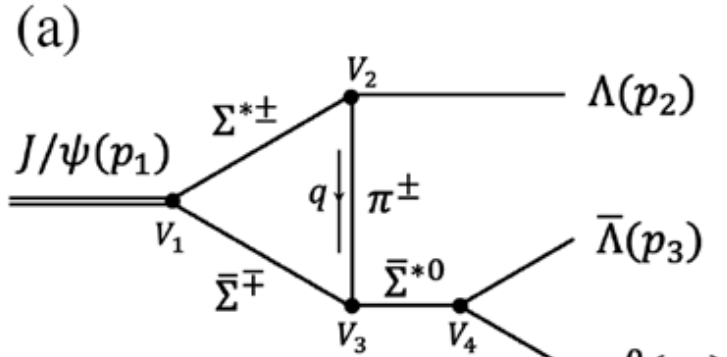

$$\Sigma^{*\pm} = \Sigma^*(1620) \frac{1^-}{2}, \Sigma^*(1670) \frac{3^-}{2}$$

$$\Sigma^{*0} = \Sigma^*(1385) \frac{3^+}{2}, \Sigma^*(1380) \frac{1^-}{2}$$

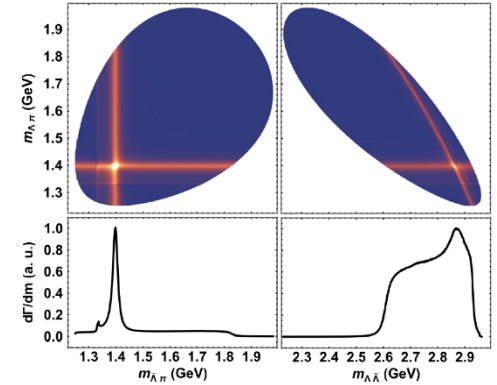
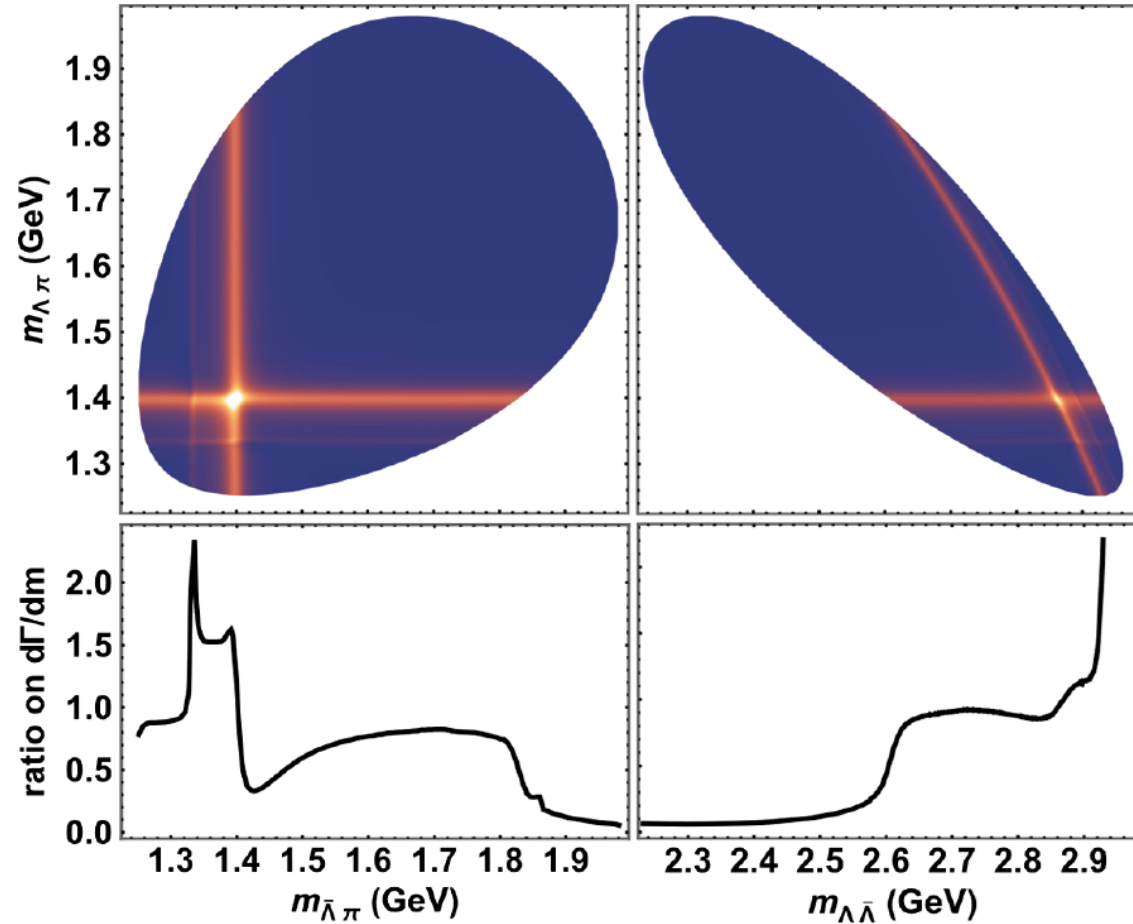

It may provide a investigation into the existence of the two $\Sigma \left(\frac{1^-}{2}\right)$ states around 1.4 GeV and 1.6 GeV.



- Two questions:
 1. Other choices
 2. Backgrounds

TS in $J/\psi \rightarrow \bar{\Lambda}\Lambda\pi$

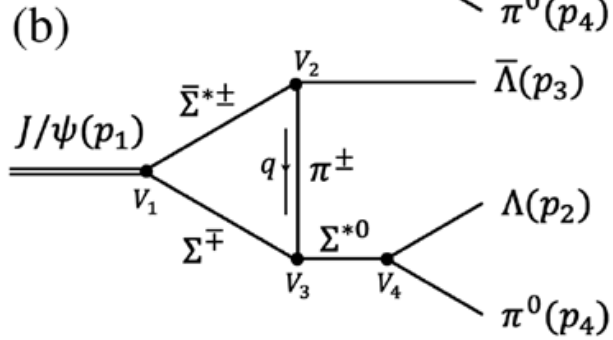
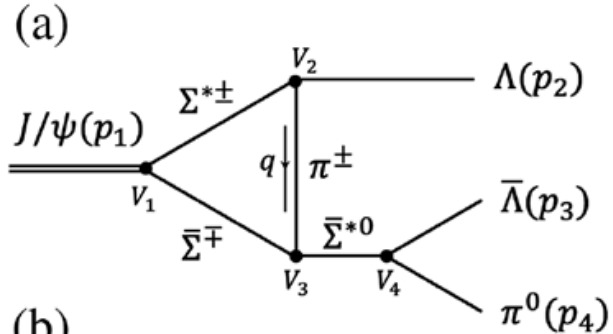

$$\Sigma^{*\pm} = \Sigma^*(1620) \frac{1}{2}^- , \Sigma^*(1670) \frac{3}{2}^-$$

$$\Sigma^{*0} = \Sigma^*(1385) \frac{3}{2}^+ , \Sigma^*(1380) \frac{1}{2}^-$$

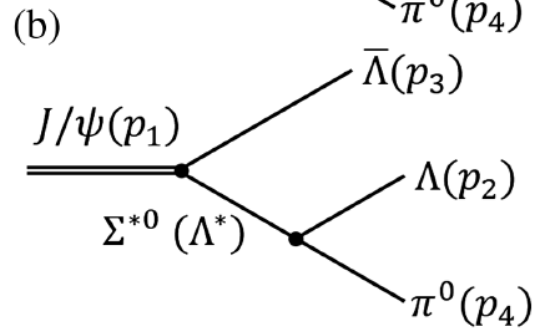
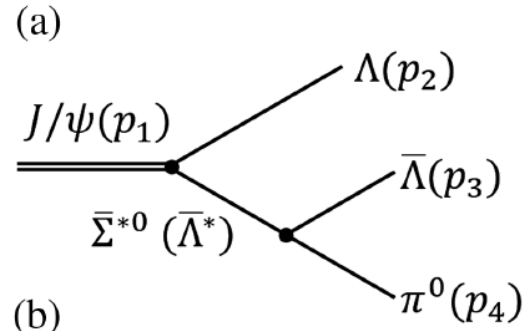

$$J/\psi \rightarrow \Sigma^{*-}(1385)\bar{\Sigma}^+ \quad Br = (3.1 \pm 0.5) \times 10^{-4}$$

$$J/\psi \rightarrow \Sigma^{*0}(1385)\bar{\Lambda} \quad Br < (4.1 \pm 0.5) \times 10^{-6}$$

So the isospin ratio is about 1%

Coupling constant	Branching ratio
$g_{\Lambda(1405)\Lambda\pi}$	$\sim 1\%$
$g_{J/\psi\Sigma(1670)\Sigma}$	$\sim 6.2 \times 10^{-5}$
$g_{J/\psi\Sigma(1620)\Sigma}$	$\sim 6.2 \times 10^{-5}$
$g_{\Sigma(1381)\Lambda\pi}$	$\sim 85\%$
$g_{\Sigma(1381)\Sigma\pi}$	$\sim 15\%$

Couplings	Branching ratio
$g_{J/\psi\Sigma(1385)\Sigma}$	$(3.1 \pm 0.5) \times 10^{-4}$
$g_{J/\psi\Sigma(1385)\Lambda}$	$< 4.1 \times 10^{-6}$
$g_{\Sigma(1385)\Lambda\pi}$	$(87.0 \pm 1.5)\%$
$g_{\Sigma(1385)\Sigma\pi}$	$(11.7 \pm 1.5)\%$
$g_{\Sigma(1620)\Lambda\pi}$	$(9.0 \pm 3.0)\%$
$g_{\Sigma(1620)\Sigma\pi}$	$(17 \pm 5)\%$
$g_{\Sigma(1670)\Lambda\pi}$	$(10 \pm 5)\%$
$g_{\Sigma(1670)\Sigma\pi}$	$(45 \pm 15)\%$
$g_{\Lambda(1405)\Sigma\pi}$	$\sim 100\%$
$g_{J/\psi\Lambda(1405)\Lambda}$	$(8.3 \pm 0.7) \times 10^{-4}$



- Two questions:
1. Other choices
 2. Backgrounds

TS in $J/\psi \rightarrow \bar{\Lambda}\Lambda\pi$

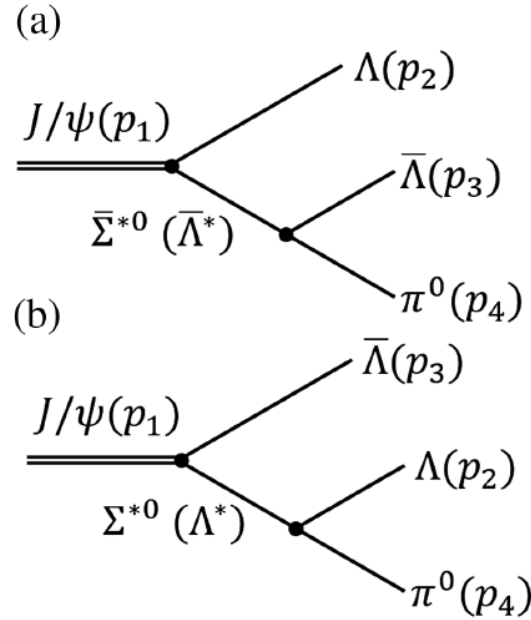
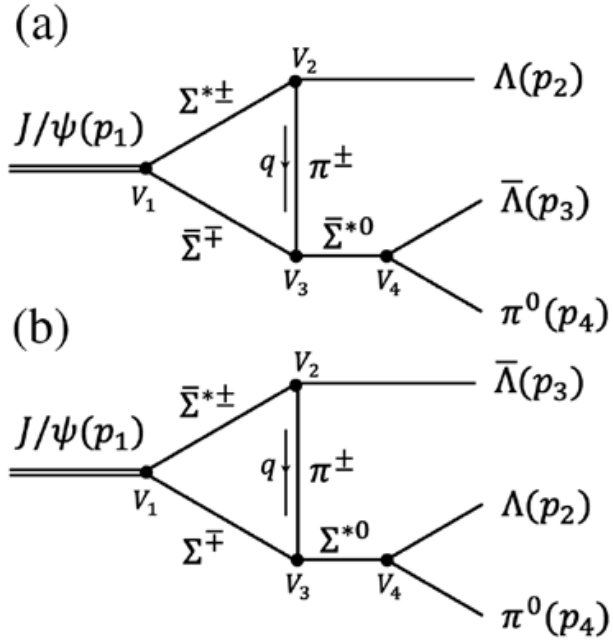

$$\Sigma^{*\pm} = \Sigma^*(1620) \frac{1}{2}^-, \Sigma^*(1670) \frac{3}{2}^-$$

$$\Sigma^{*0} = \Sigma^*(1385) \frac{3}{2}^+, \Sigma^*(1380) \frac{1}{2}^-$$

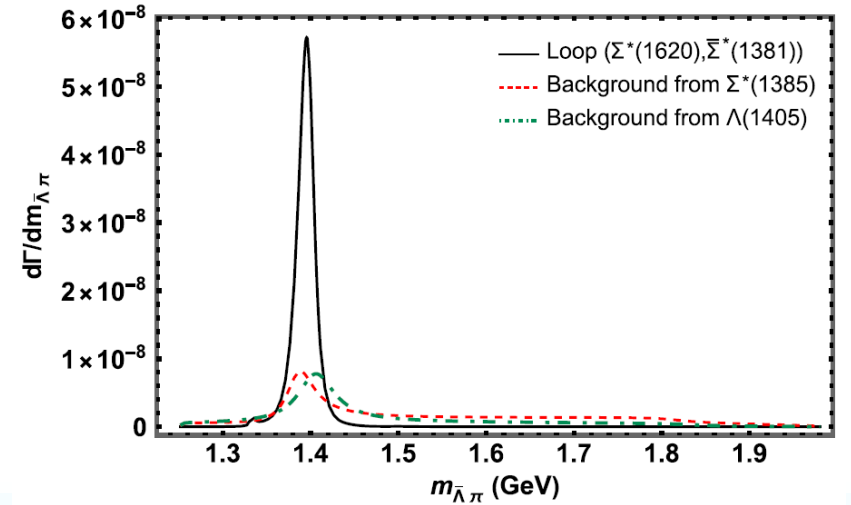
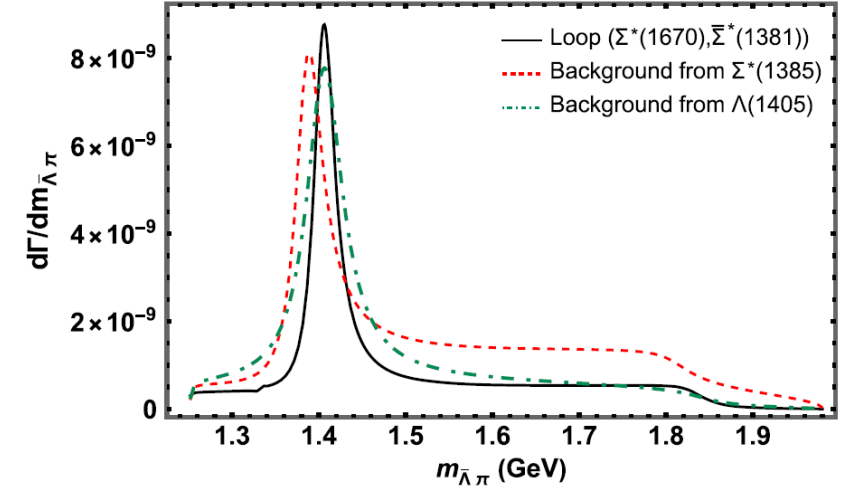

Summary

We discuss the Triangle Singularity plus the iso-spin breaking, we find that the role of TS will be much more important in the iso-spin breaking process.

We propose the triangle loop in $J/\psi \rightarrow \bar{\Lambda}\Lambda\pi$, where **TS may play an important role.**

Once such TS peak can be confirmed, **it would provide the existence of the two $\Sigma\left(\frac{1}{2}^{-}\right)$ states around 1.4 GeV and 1.6 GeV.**

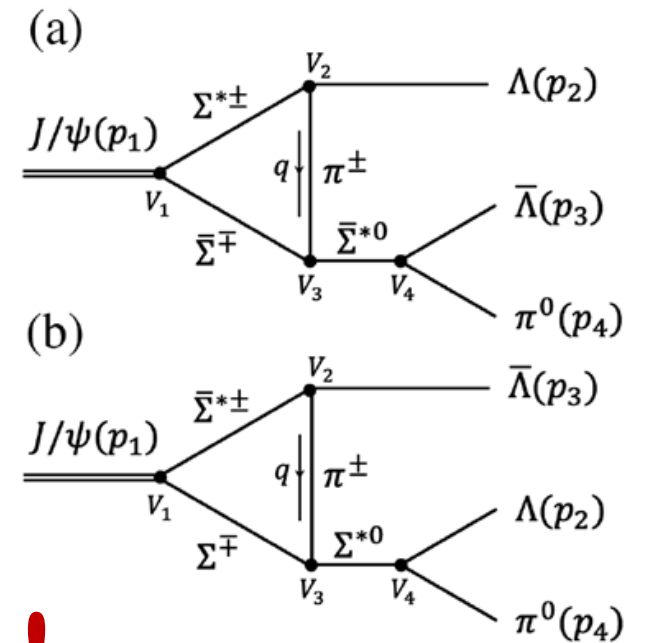

Thanks for attention!

