

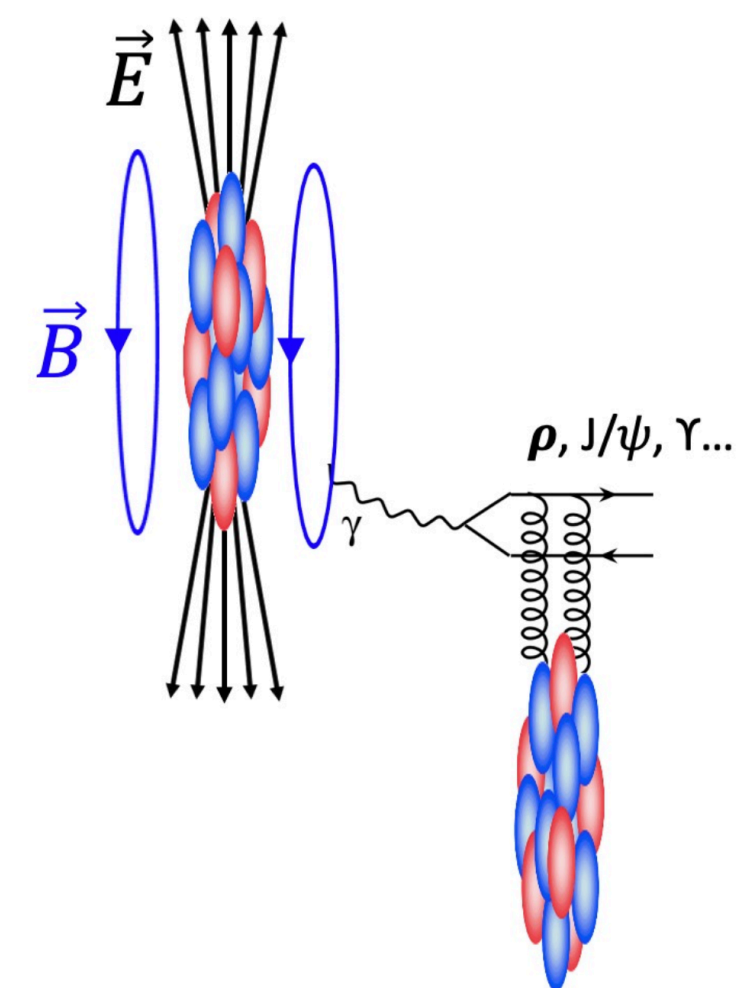

The recent measurements of ultra-peripheral collisions

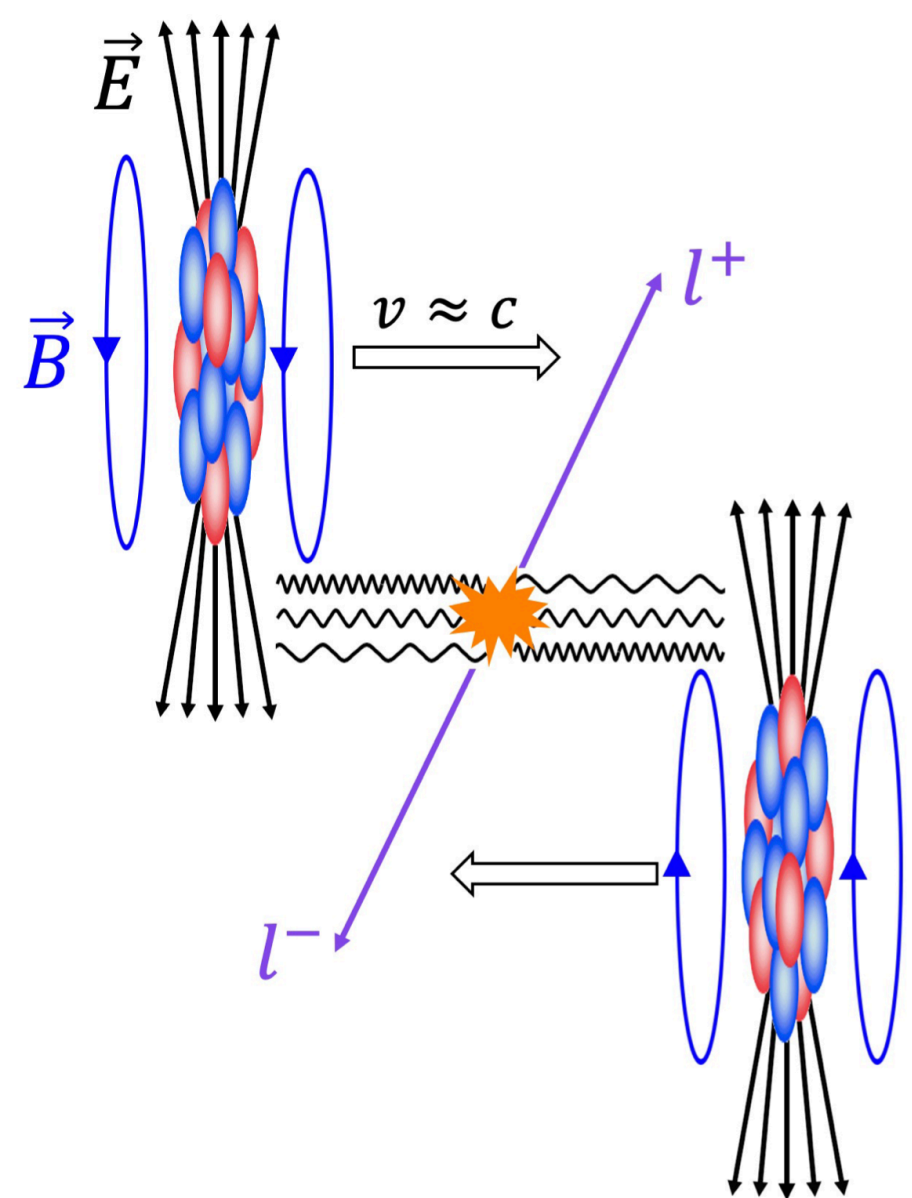

杨帅
华南师范大学

第十四届全国粒子物理学术会议, 青岛, 2024年8月14日-18日

Equivalent photon

◎ Equivalent Photon Approximation

- Photon Flux $\propto Z^2$
- $Q^2 \sim 0$ (quasi real photon)

Fermi, Z. Phys. 29 (1924) 315
 Williams, Phys. Rev. 45 (1934) 729
 Weizsacker, Z. Phys. 88 (1934) 612

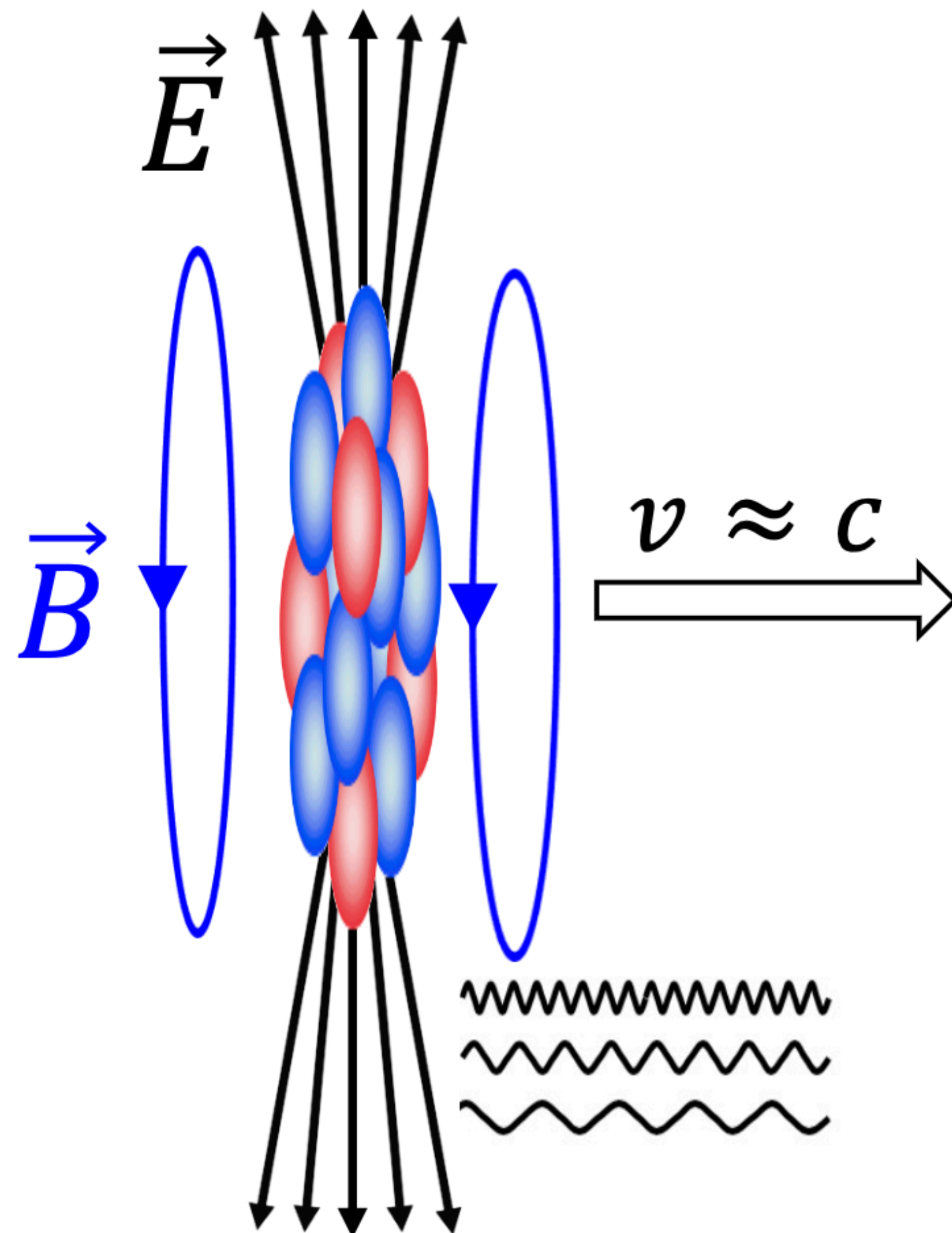

◎ Photon kinematics

maximum energy $E_{\gamma, \max} \sim \gamma(\hbar c/R)$	80 GeV in Pb+Pb@LHC 3 GeV in Au+Au@RHIC
typical p_T (& virtuality) $p_{T\max} \sim \hbar c/R$	O(30) MeV @ RHIC & LHC
Coherent strengths (rates) scale as Z^2 : nuclei \gg protons	Flux of photons on other nucleus $\sim Z^2$, flux of photons on photons $\sim Z^4$ (45M!)

Photon-photon interactions

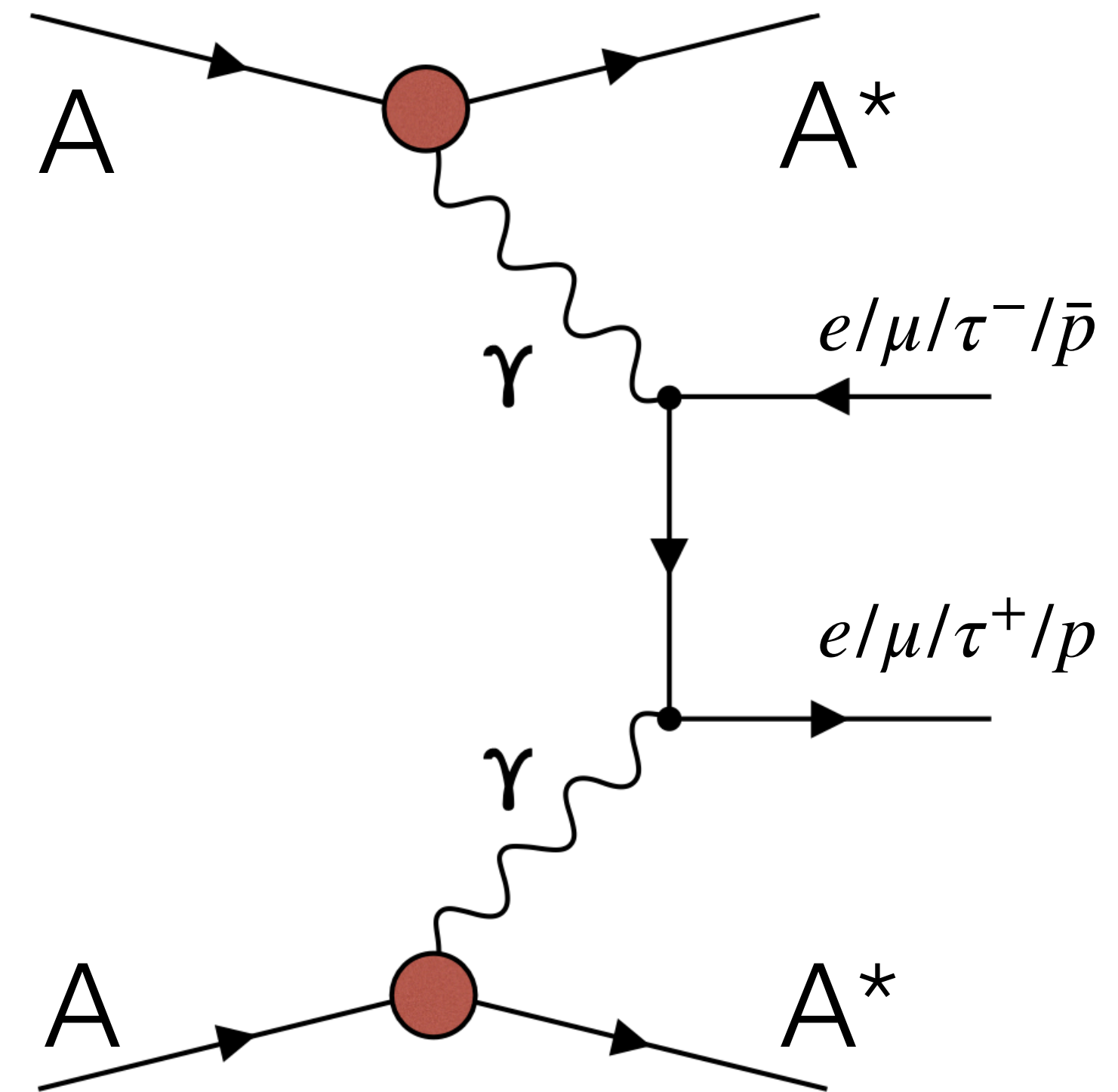
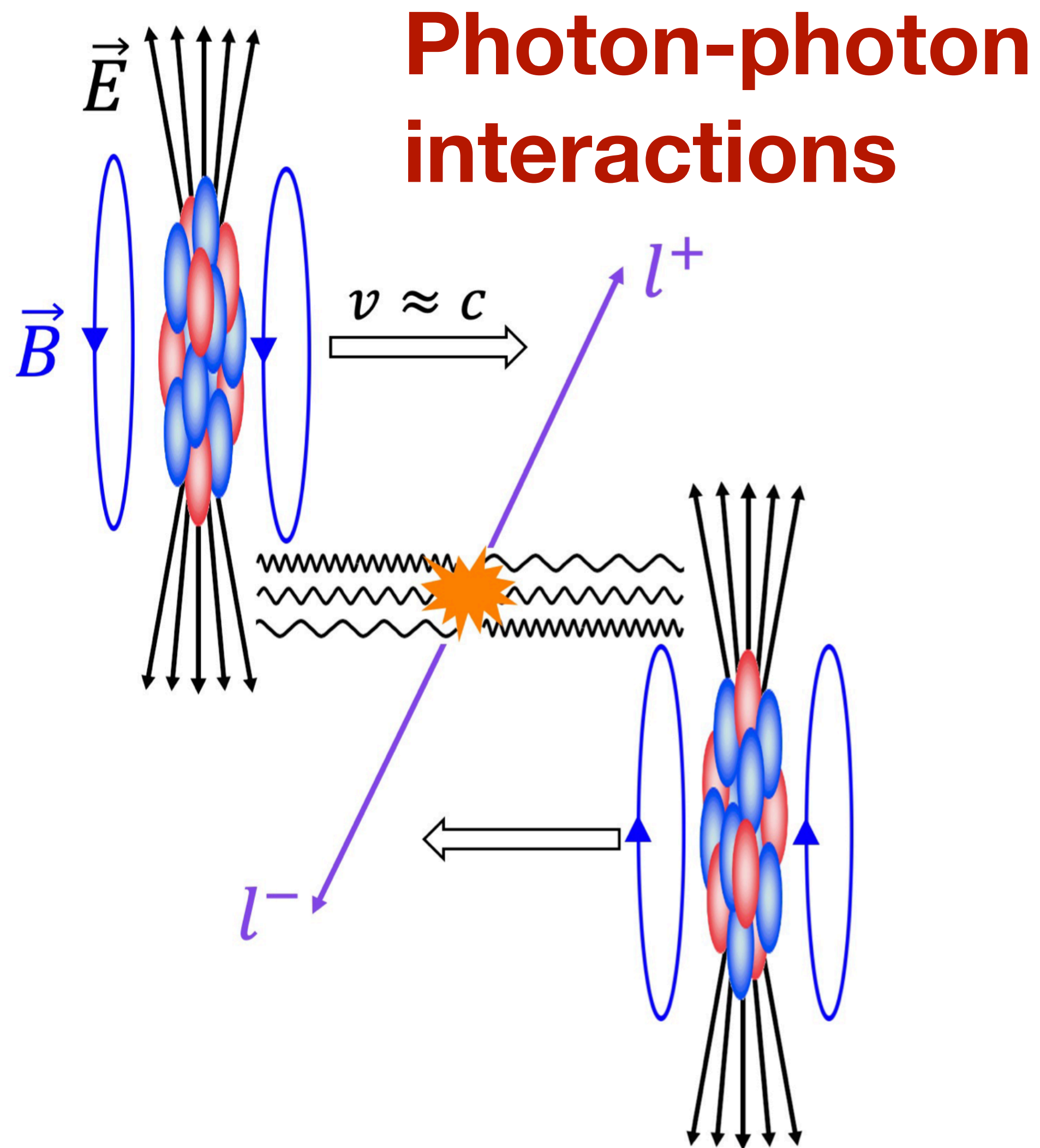

- QED
- BSM physics

Concluded the b dependence of photon p_T

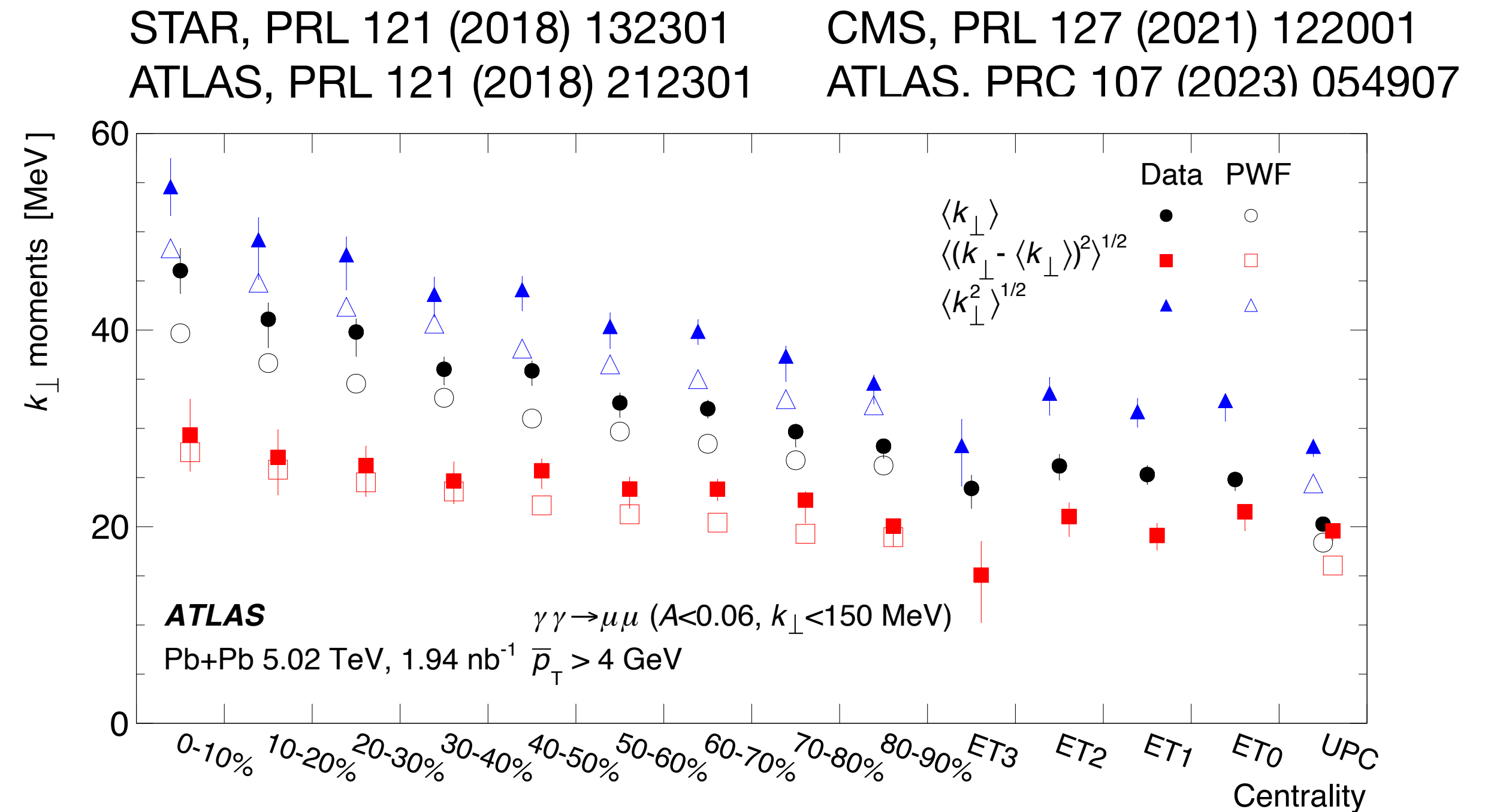
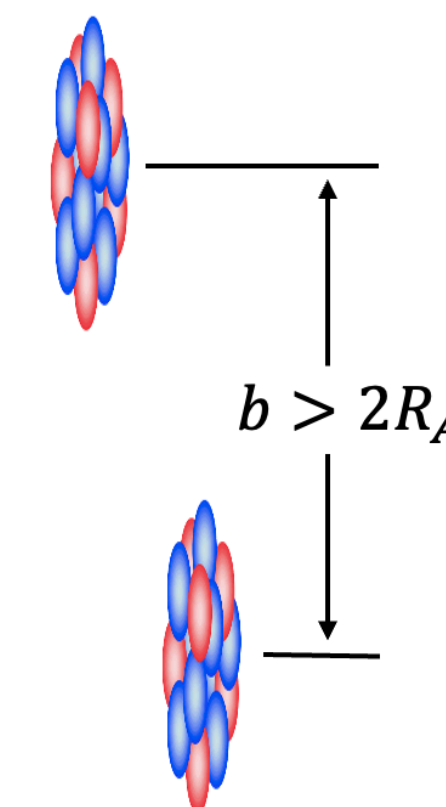
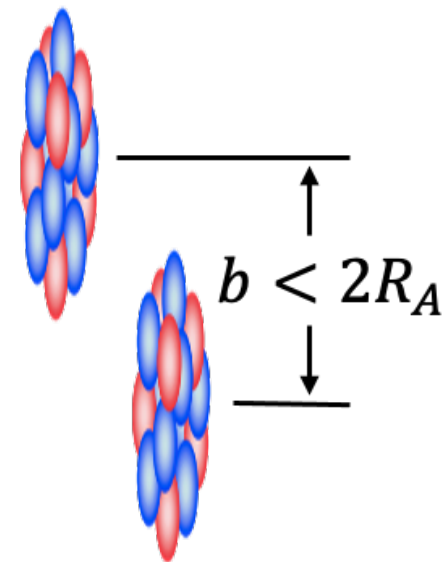
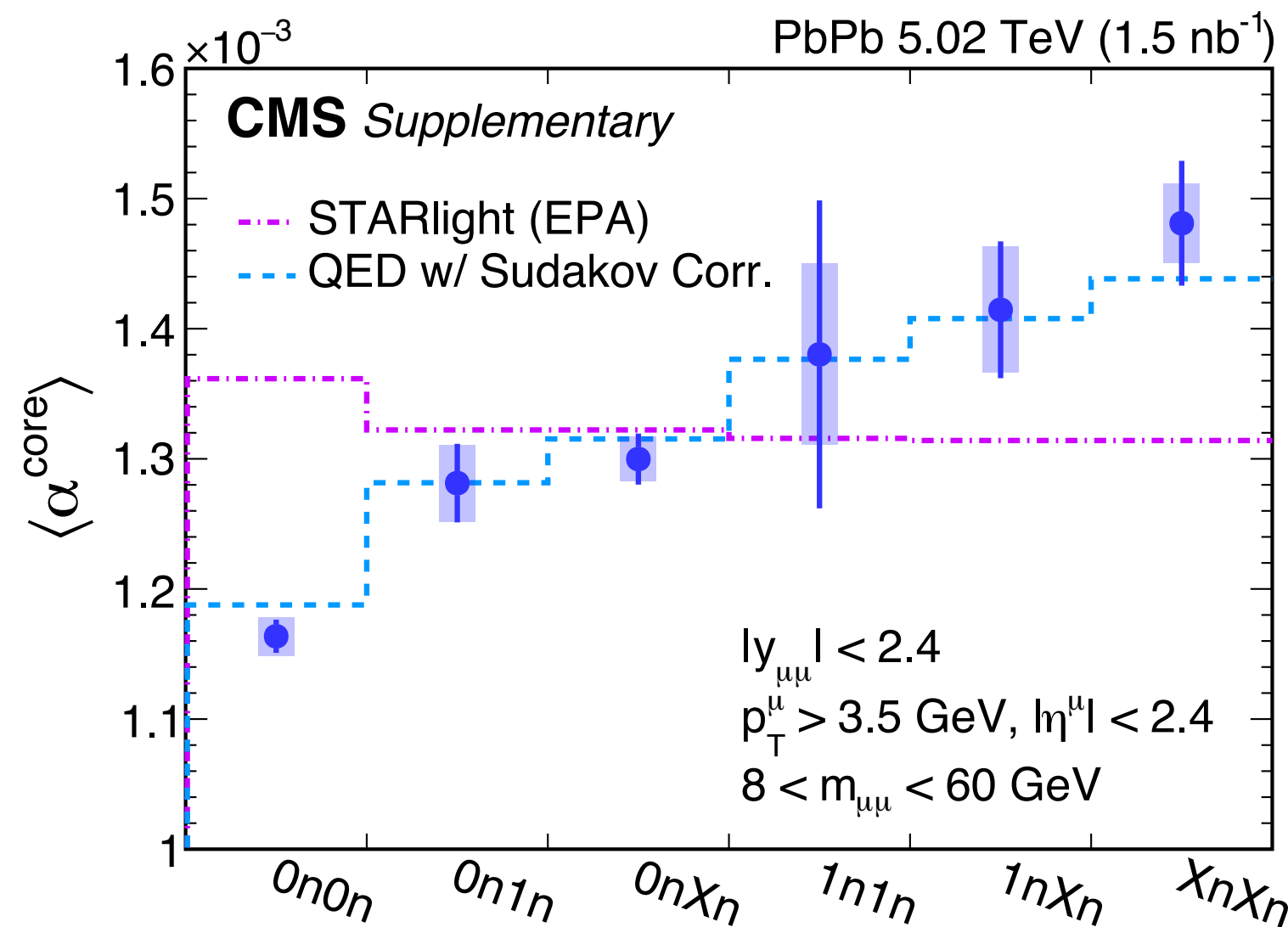
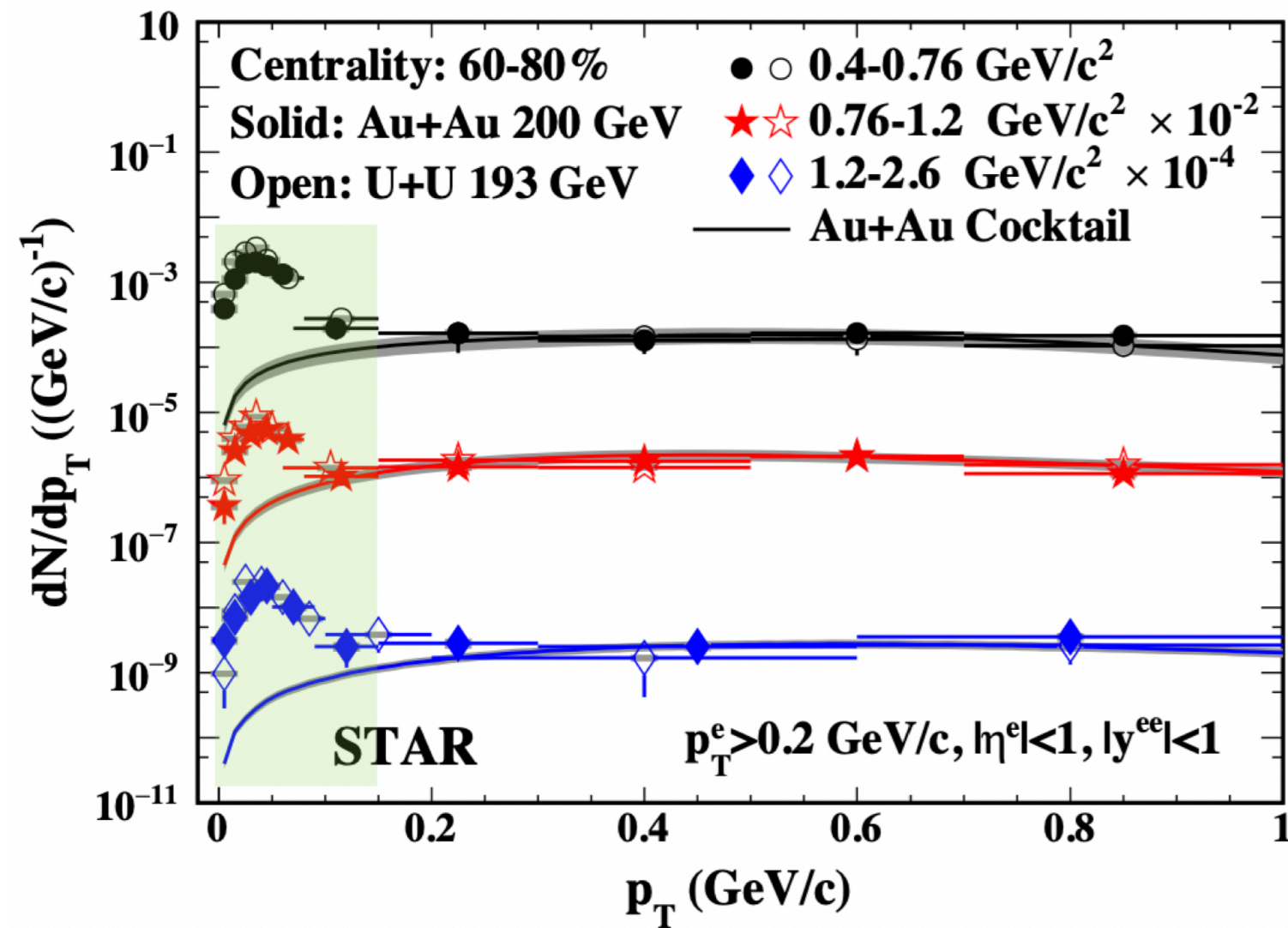

smaller b ← larger b

- Observed Breit-Wheeler process in non-UPC
 - Probe QGP medium with $\gamma\gamma \rightarrow l^+l^-$
- Demonstrated the b dependence of photon p_T
 - Precise reference for probing QGP EM effects

Experimental signature of linearly polarized photons

Li, Zhou, and Zhou, PLB 795 (2019) 576

STAR, PRL 127 (2021) 052302

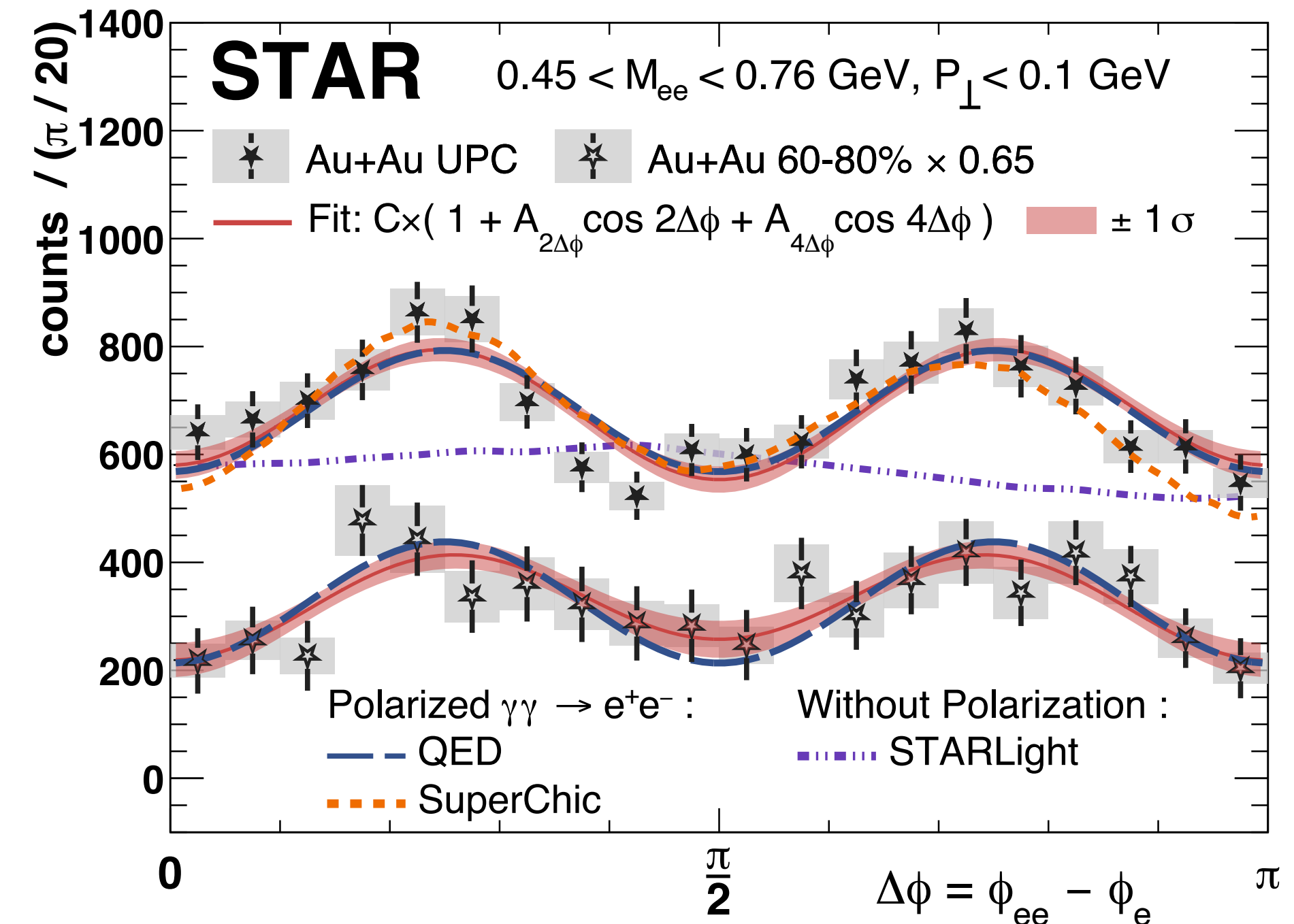
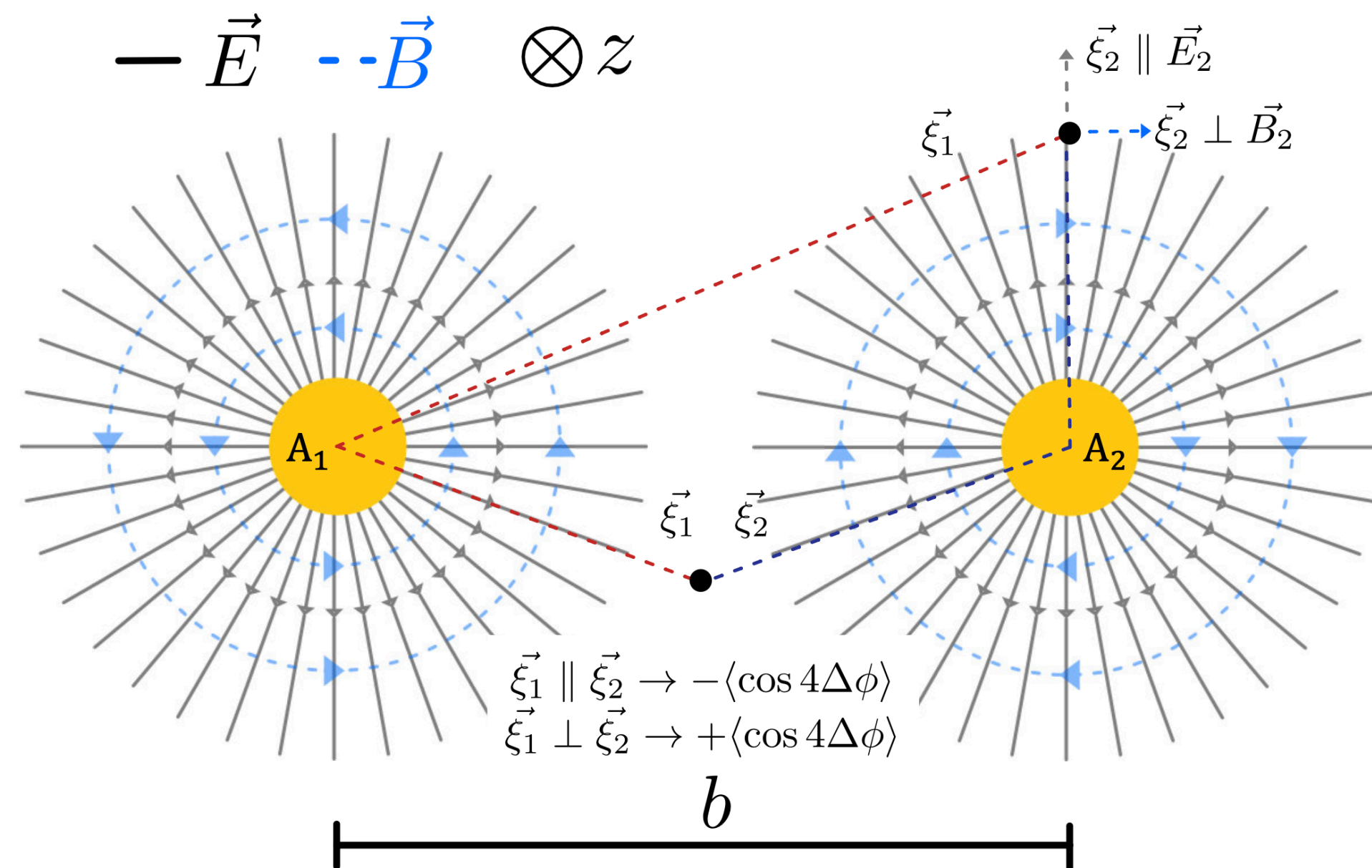

- Different helicity amplitude combinations for linearly polarized photons lead to a splitting of angular modulation
- Experimentally observe that photons are linearly polarized
 - UPC: $A_{4\Delta\phi}$ observed with $> 6\sigma$
 - non-UPC: $A_{4\Delta\phi}$ observed with $> 4\sigma$



Observation of $\gamma\gamma \rightarrow \tau\tau$ in AA

CMS Experiment at the LHC, CERN

Data recorded: 2015-Dec-06 21:41:27.033612 GMT

Run / Event / LS: 263400 / 88515785 / 849

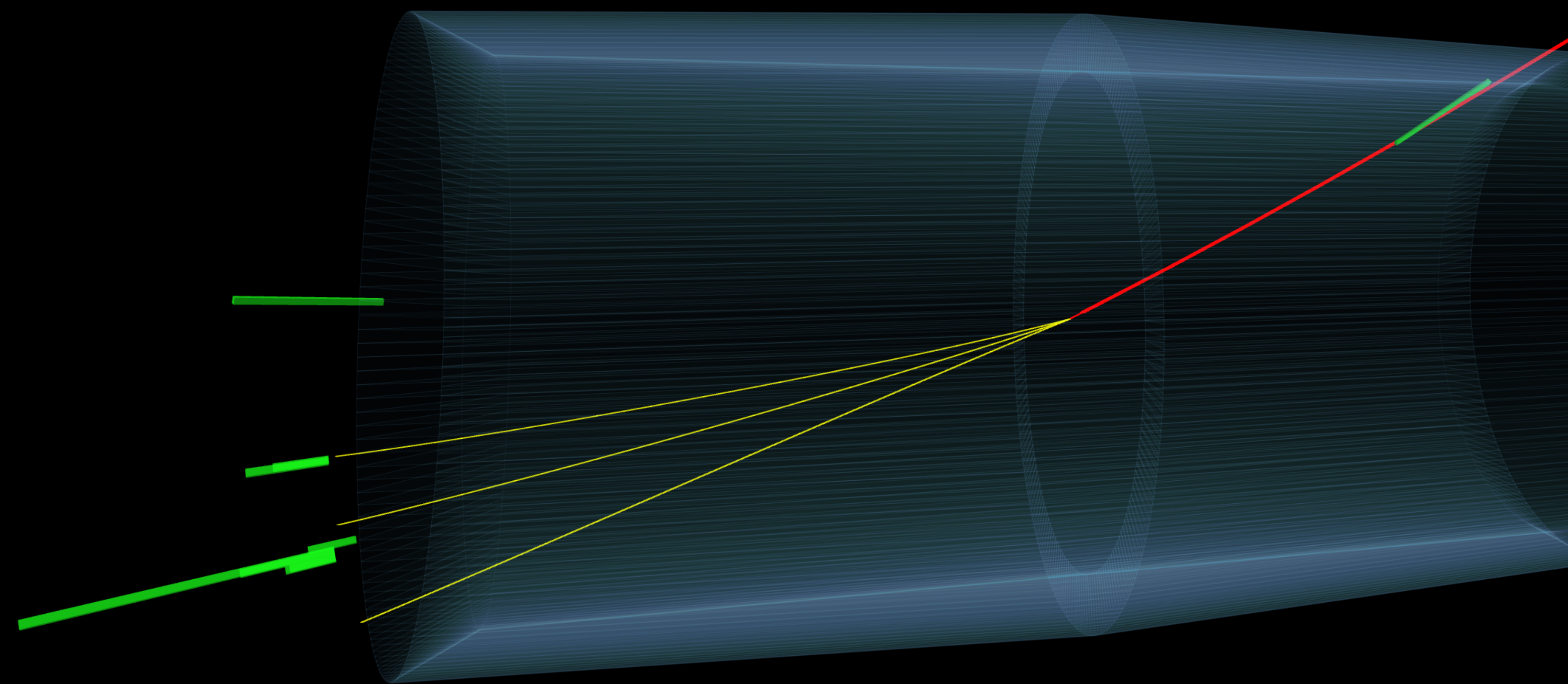
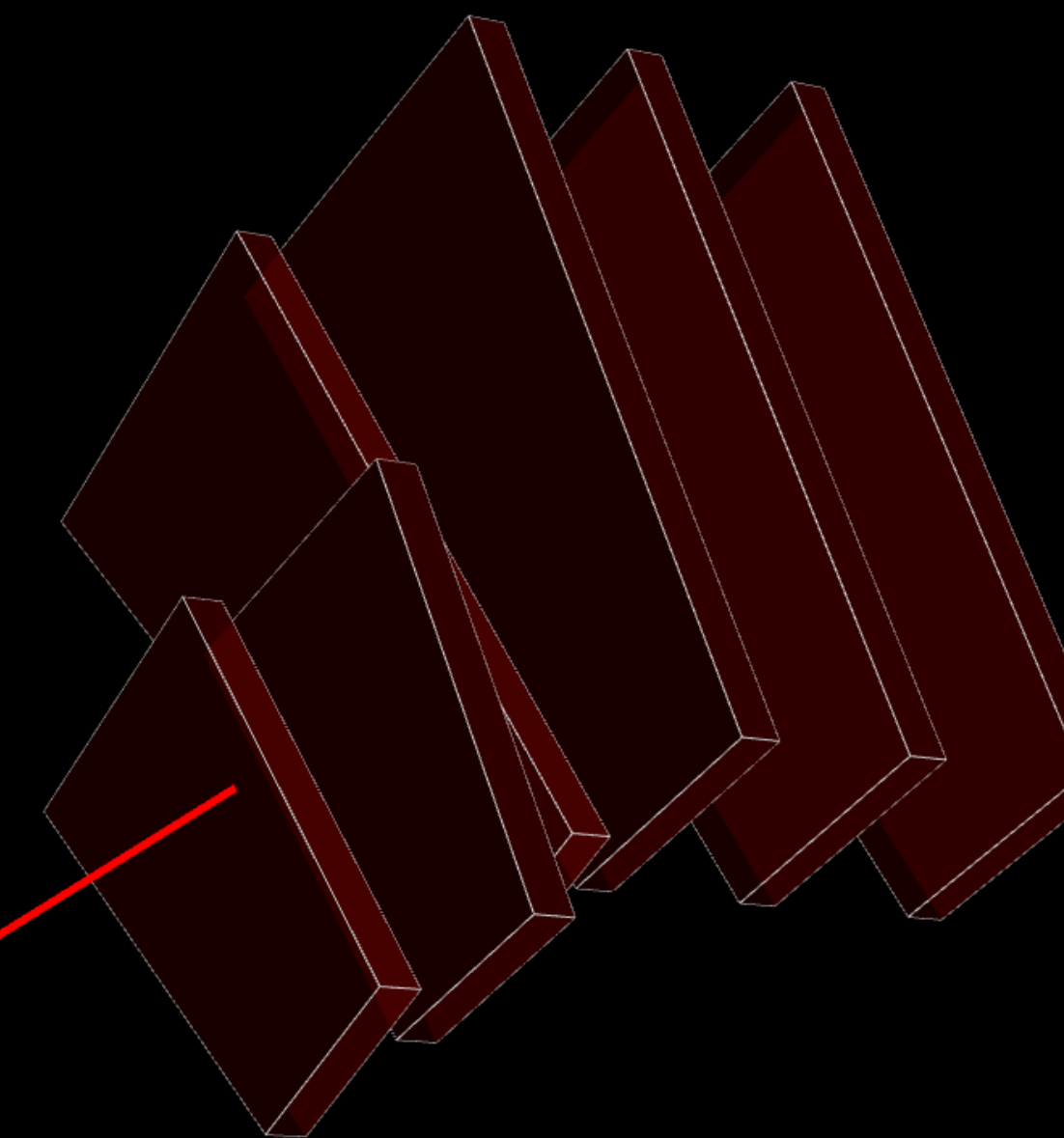

ATLAS, PRL 131 (2023) 151802
CMS, PRL 131 (2023) 151803

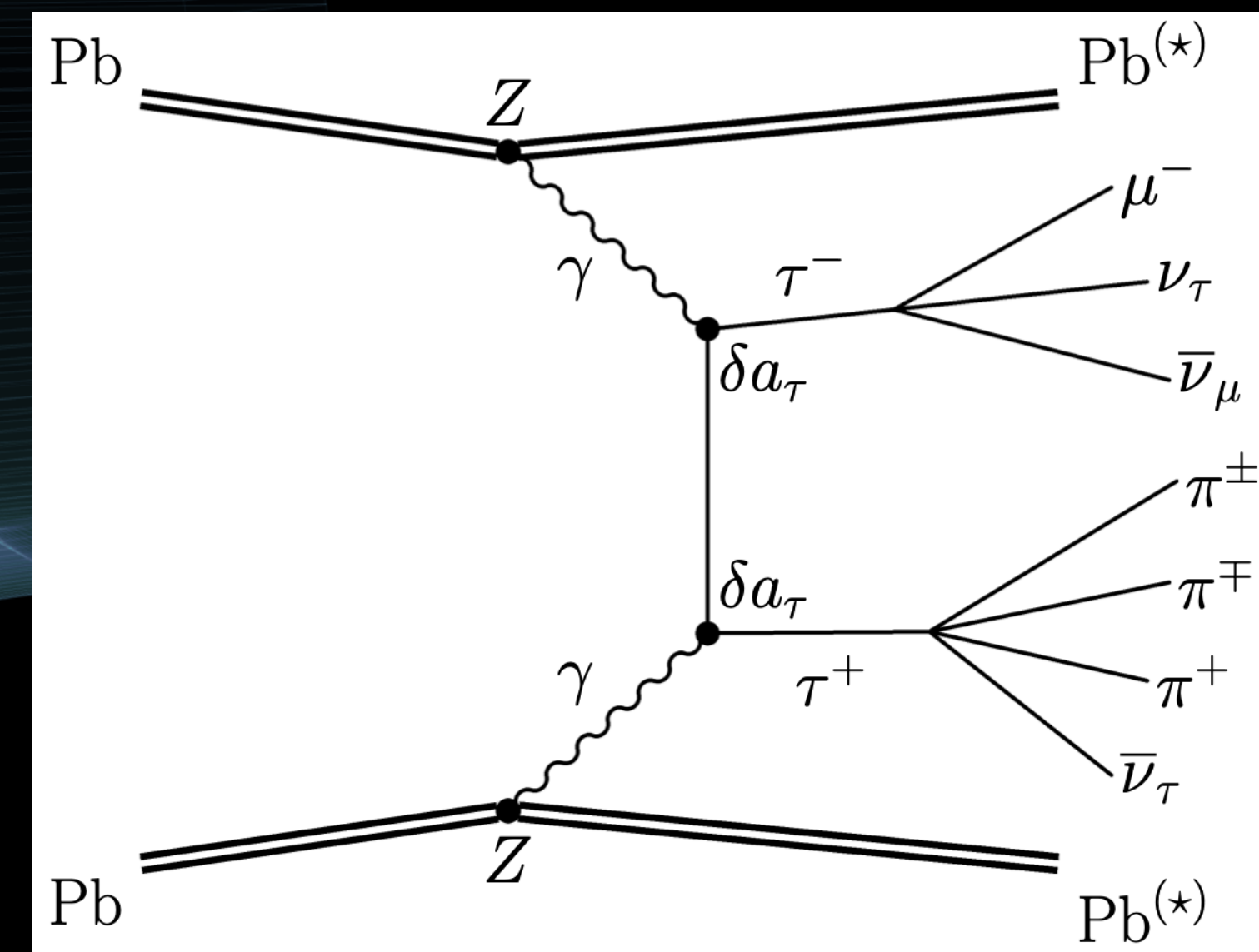

Constrain $a_\tau = (g_\tau - 2)/2$

ATLAS, PRL 131 (2023) 151802

CMS, PRL 131 (2023) 151803

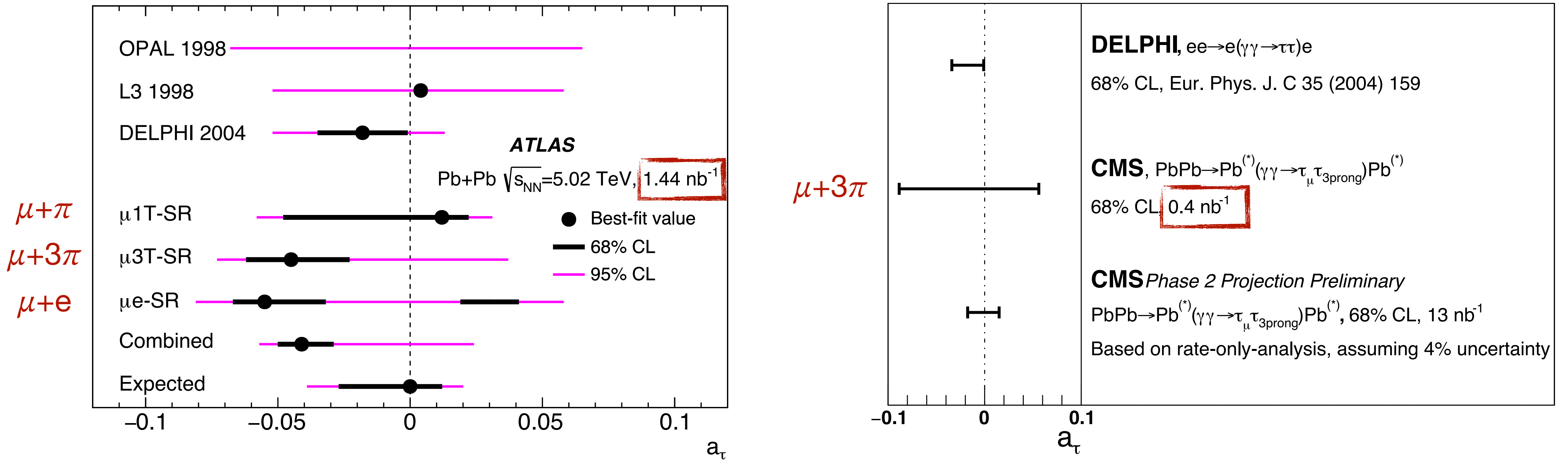

- ◎ Sensitivity to the BSM physics
 - Model-dependent value of a_τ
 - Comparable with DELPHI result

Higher excitation of QED vacuum

Zhang, Zhang, and Shao, arxiv: 2406.05618

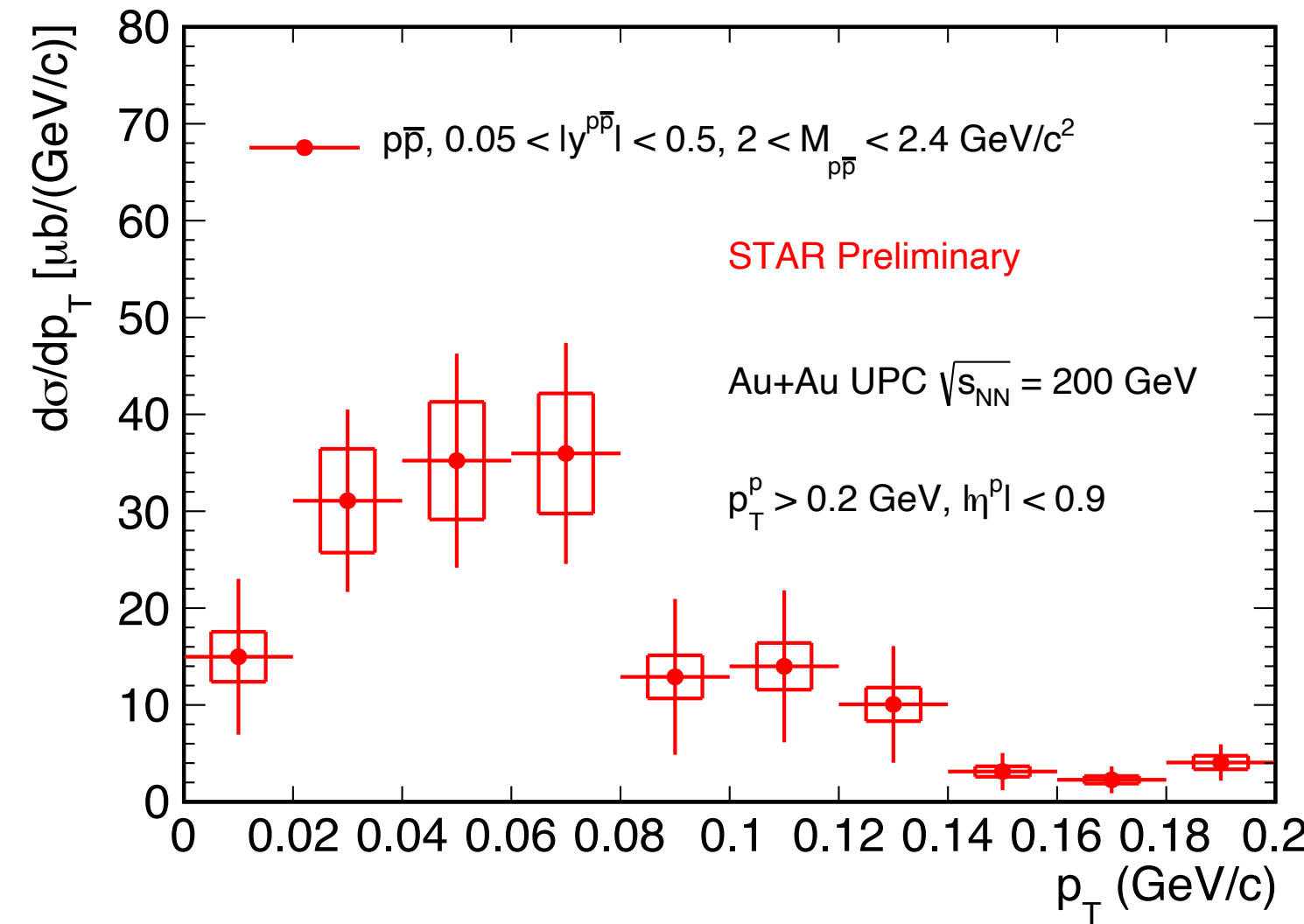
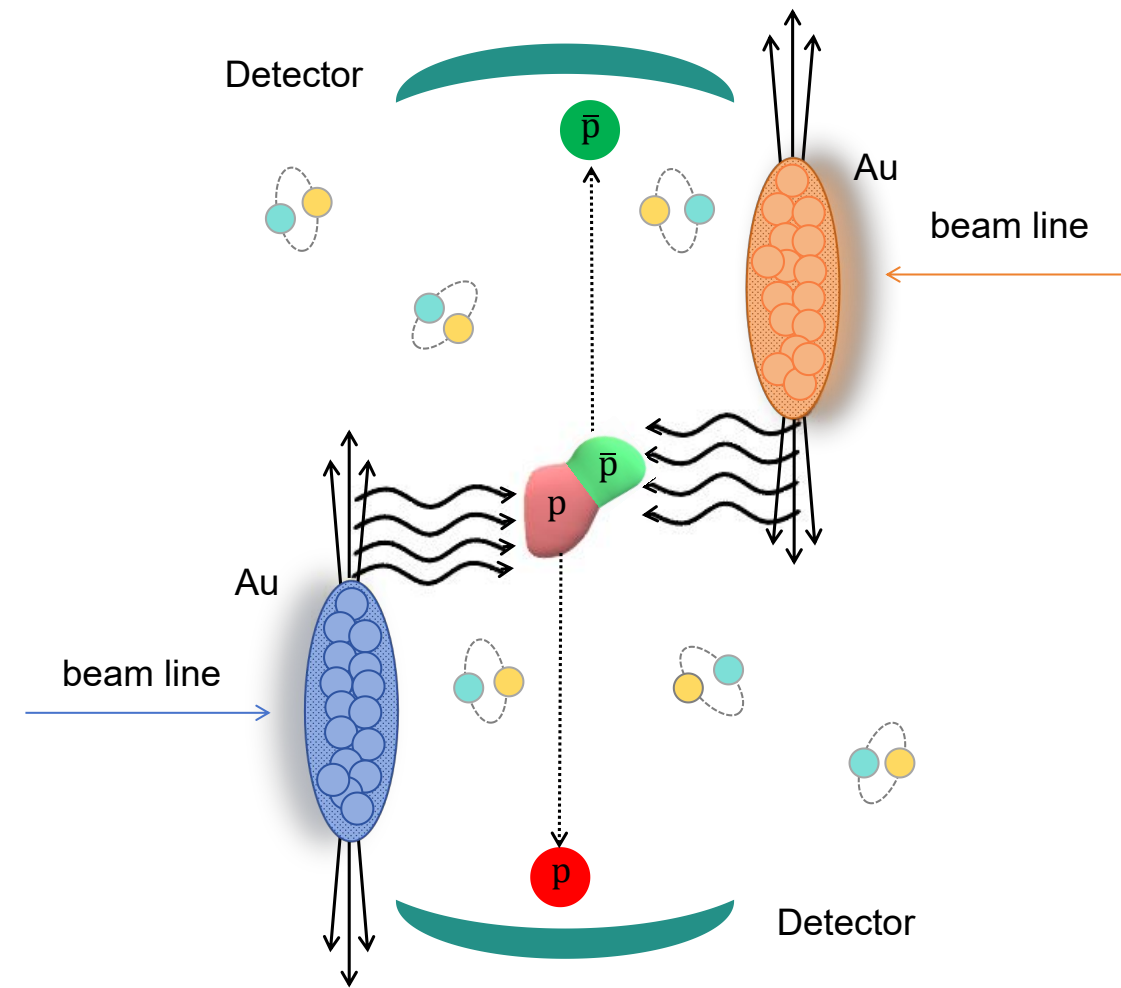

- ◎ First observation of $\gamma\gamma \rightarrow$ dibaryon production in UPC
 - Contribution of Drell-Söding process is significantly lower than data
 - Consistent with $\gamma\gamma \rightarrow p\bar{p}$ production

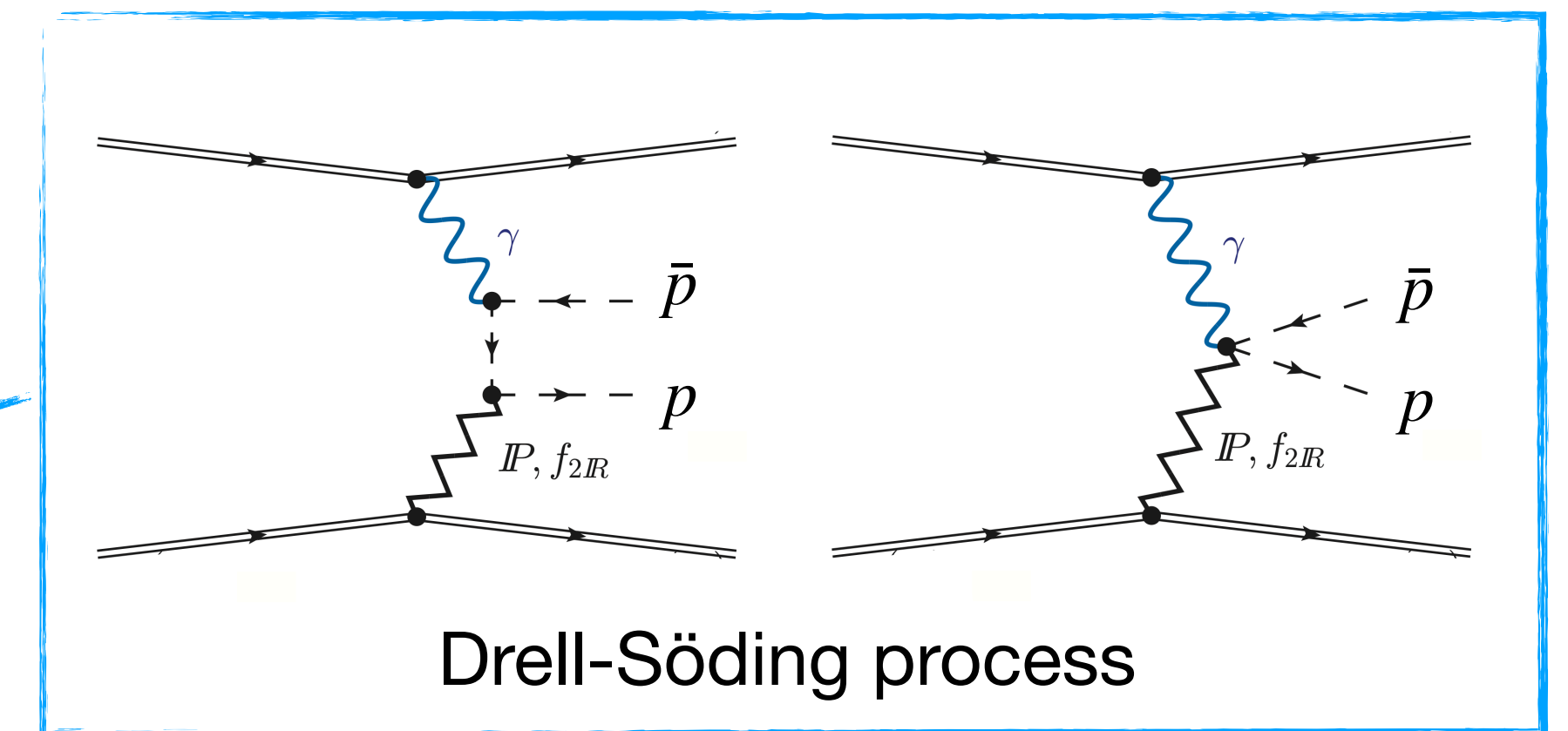
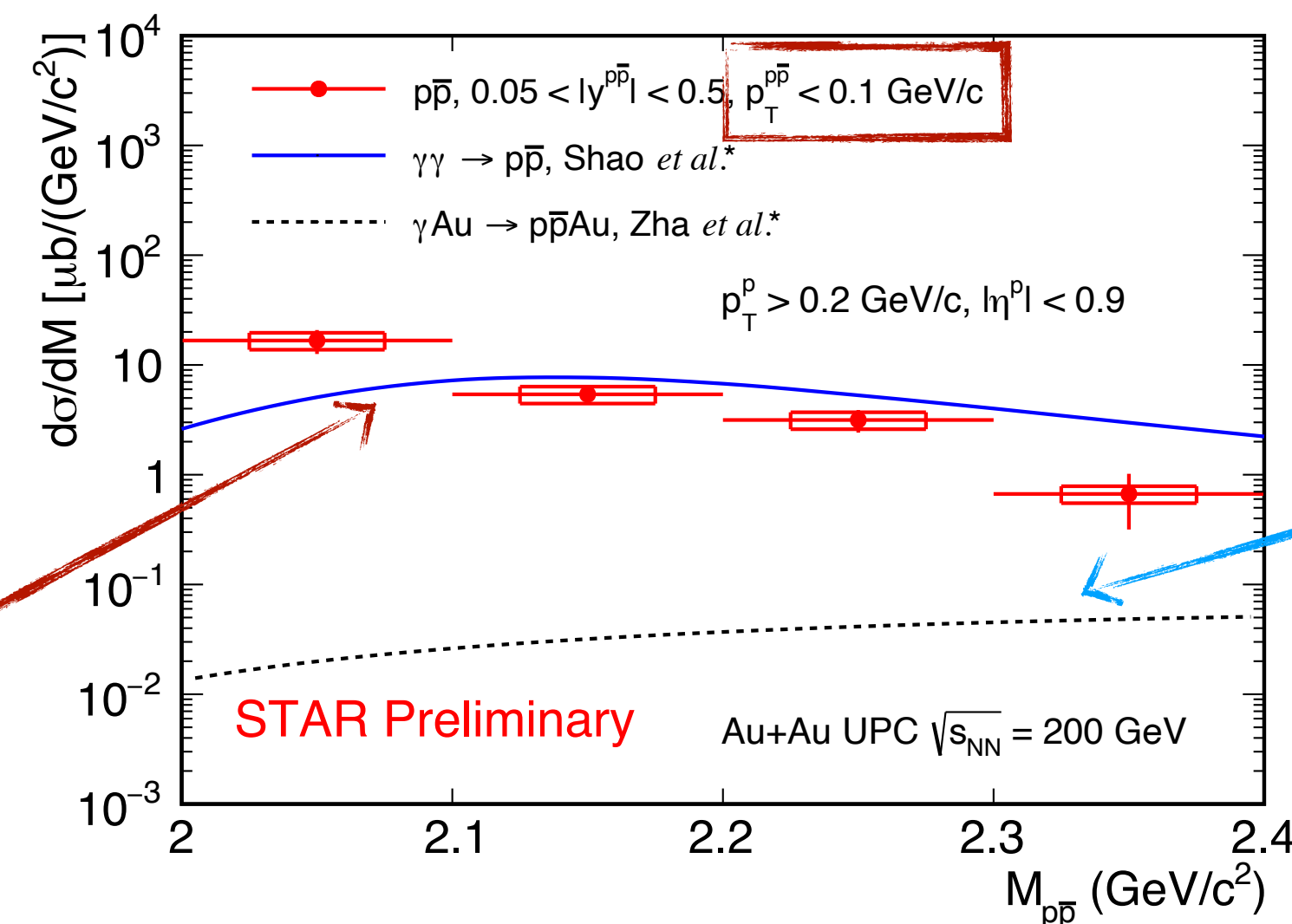
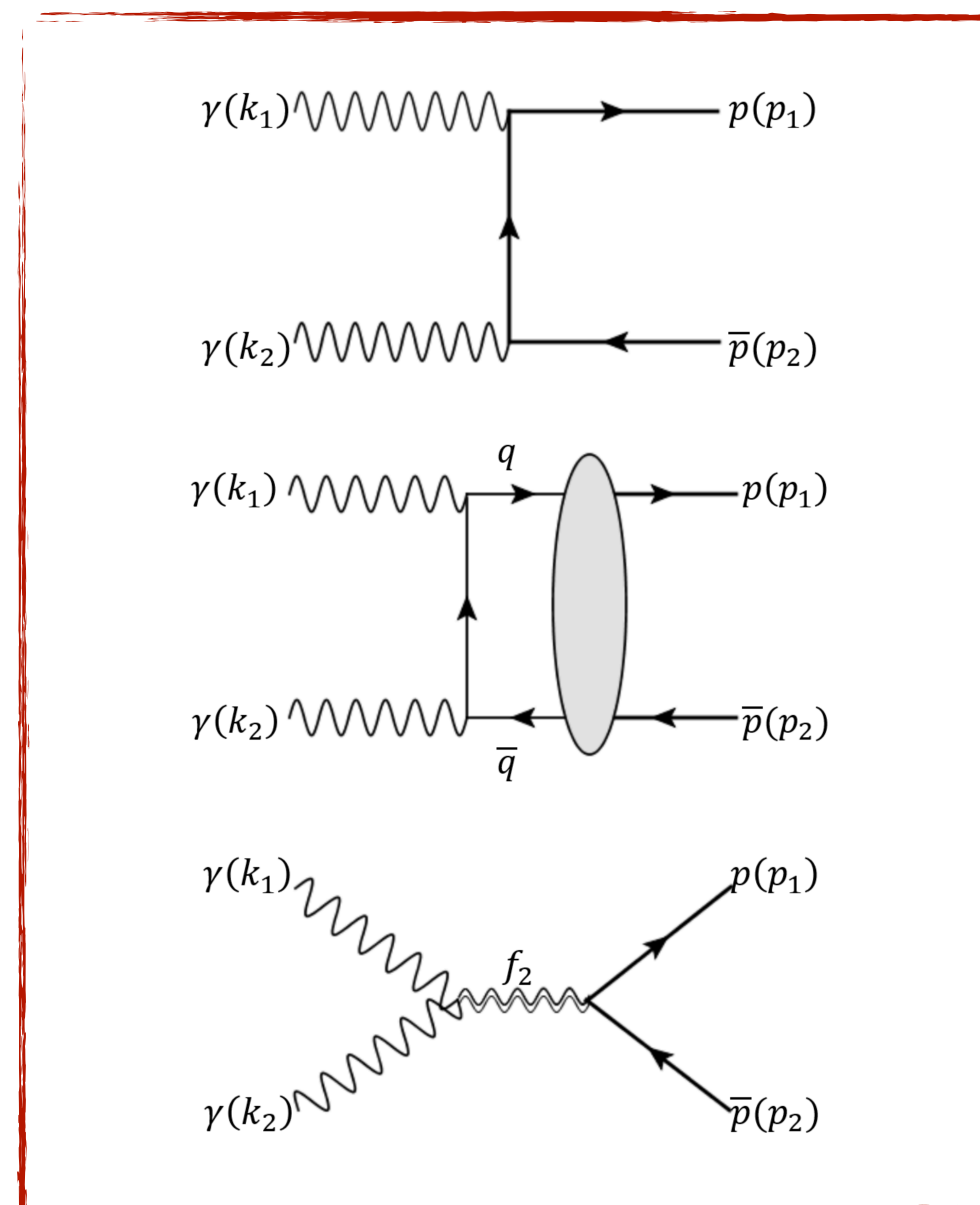

Photon-nuclear interactions

Photon-nuclear interactions

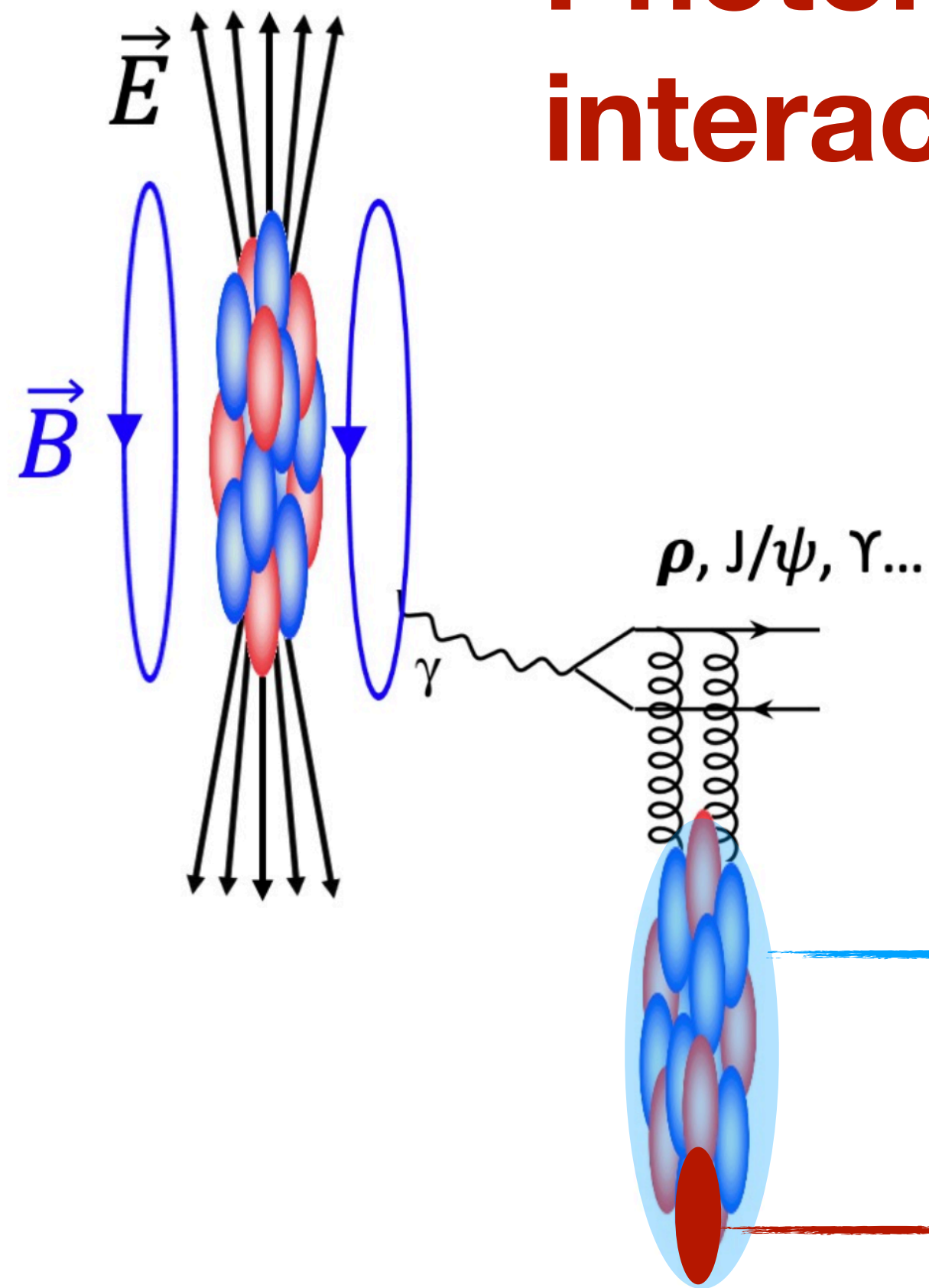

Drell-Söding process

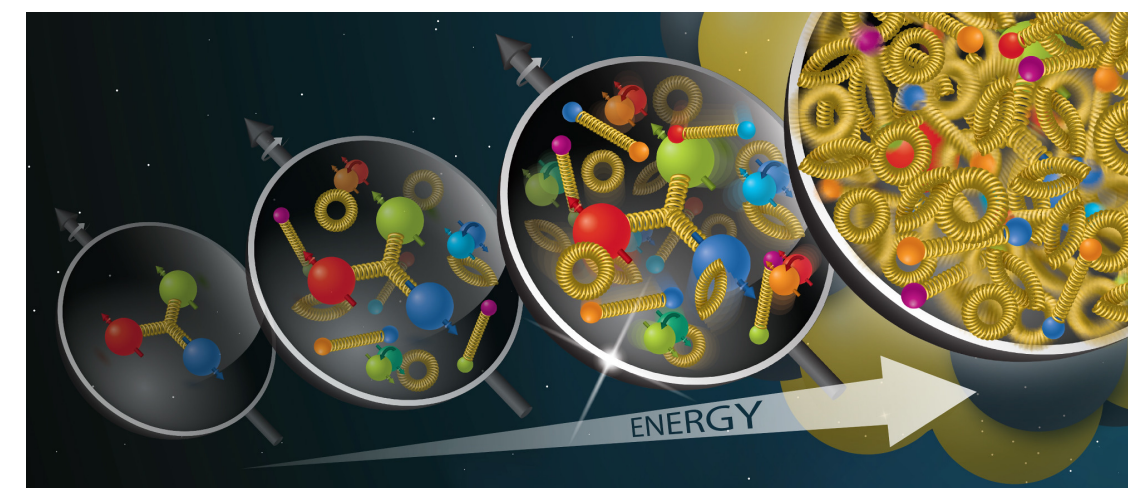
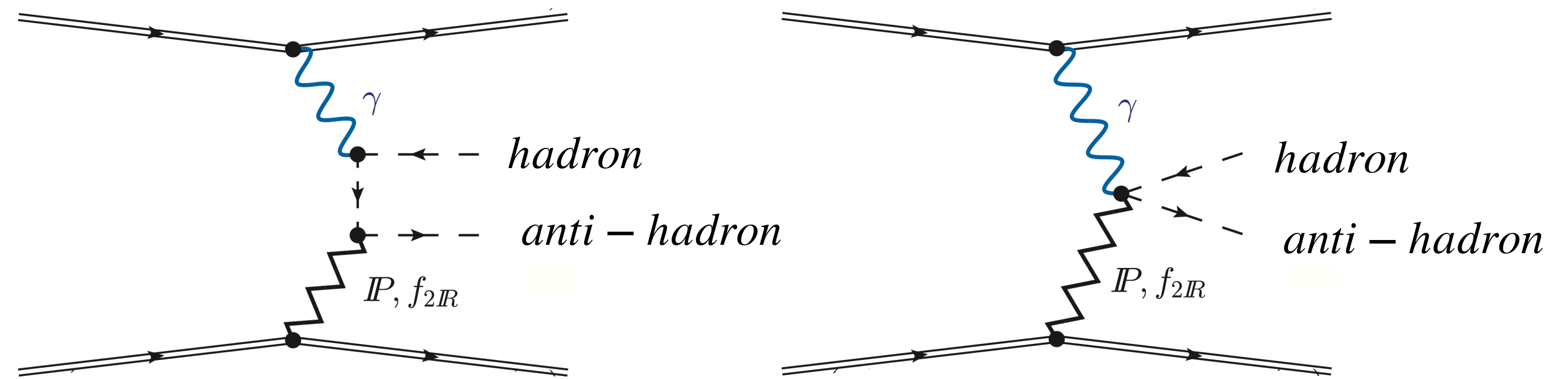

gluonic structure

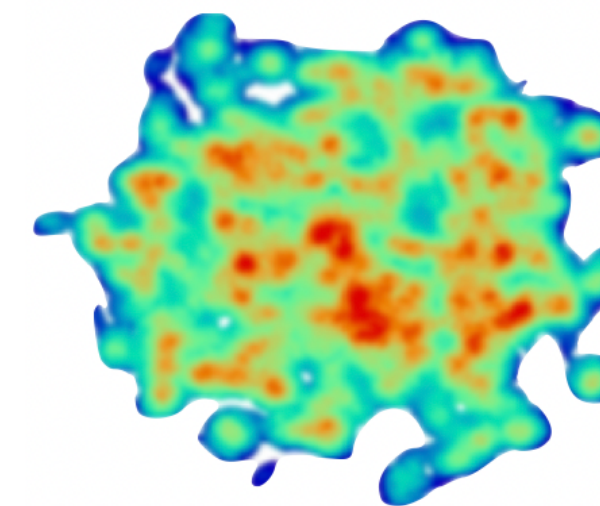

sub-nucleon fluctuation

© Little "EIC"

Photoproduction of K^+K^- pairs

ALICE, PRL 132 (2024) 222303

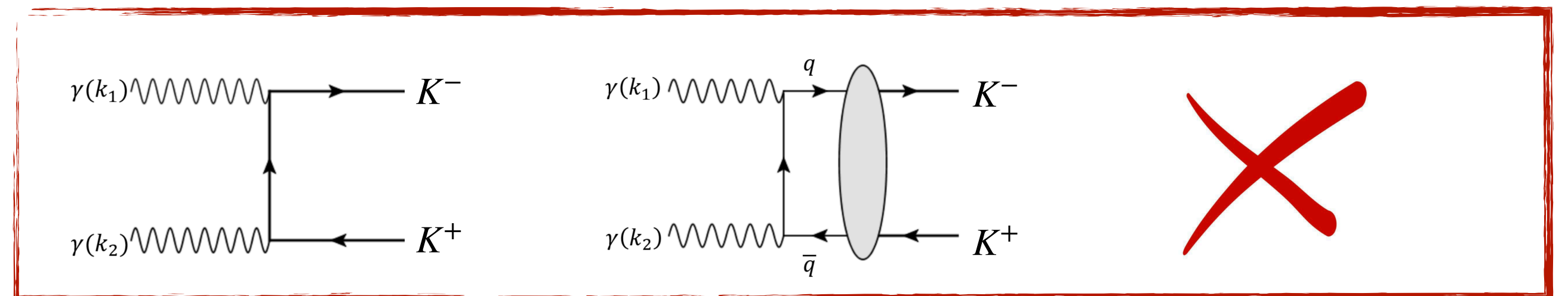
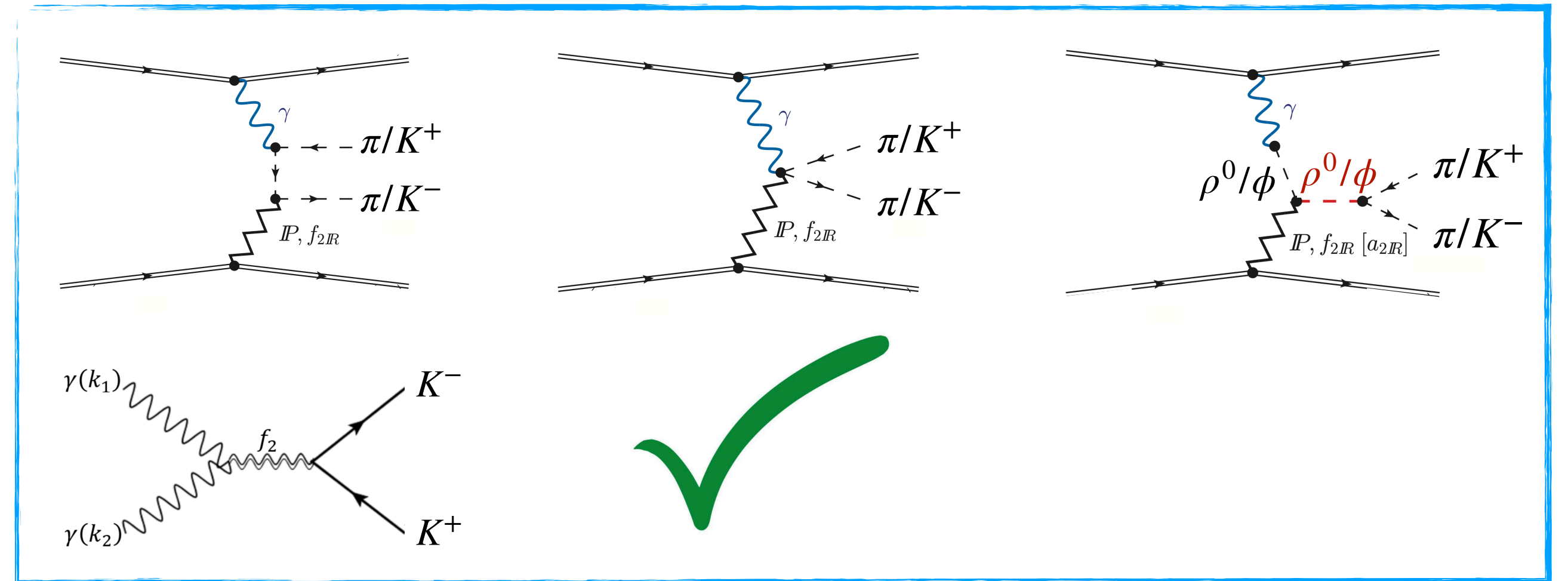
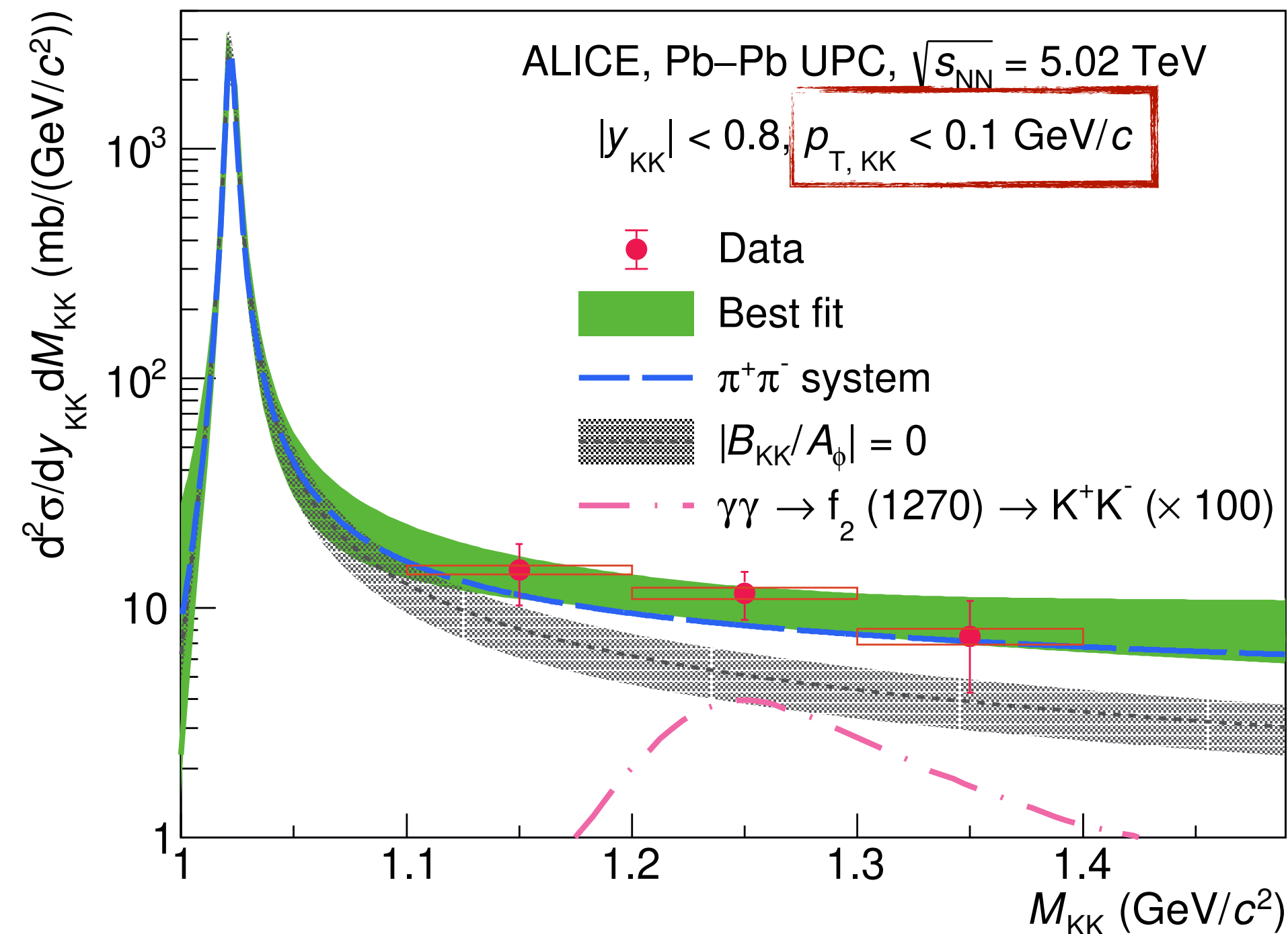

- Data favor the coherent $\phi(1020) \rightarrow K^+K^-$ + direct K^+K^- photoproduction, with interference considered
 - The contribution of $\gamma\gamma \rightarrow K^+K^-$ is not estimated

Imaging heavy nuclear with coherent J/ψ

ALICE, EPJC 81 (2021) 712
CMS, PRL 131 (2023) 262301
LHCb, JHEP 06 (2023) 146

- ◉ LHC experiments complement each over a wide range of y region

- $R_g^{Pb} = 0.64 \pm 0.04$ at $x \sim 10^{-3}$ ($y=0$)

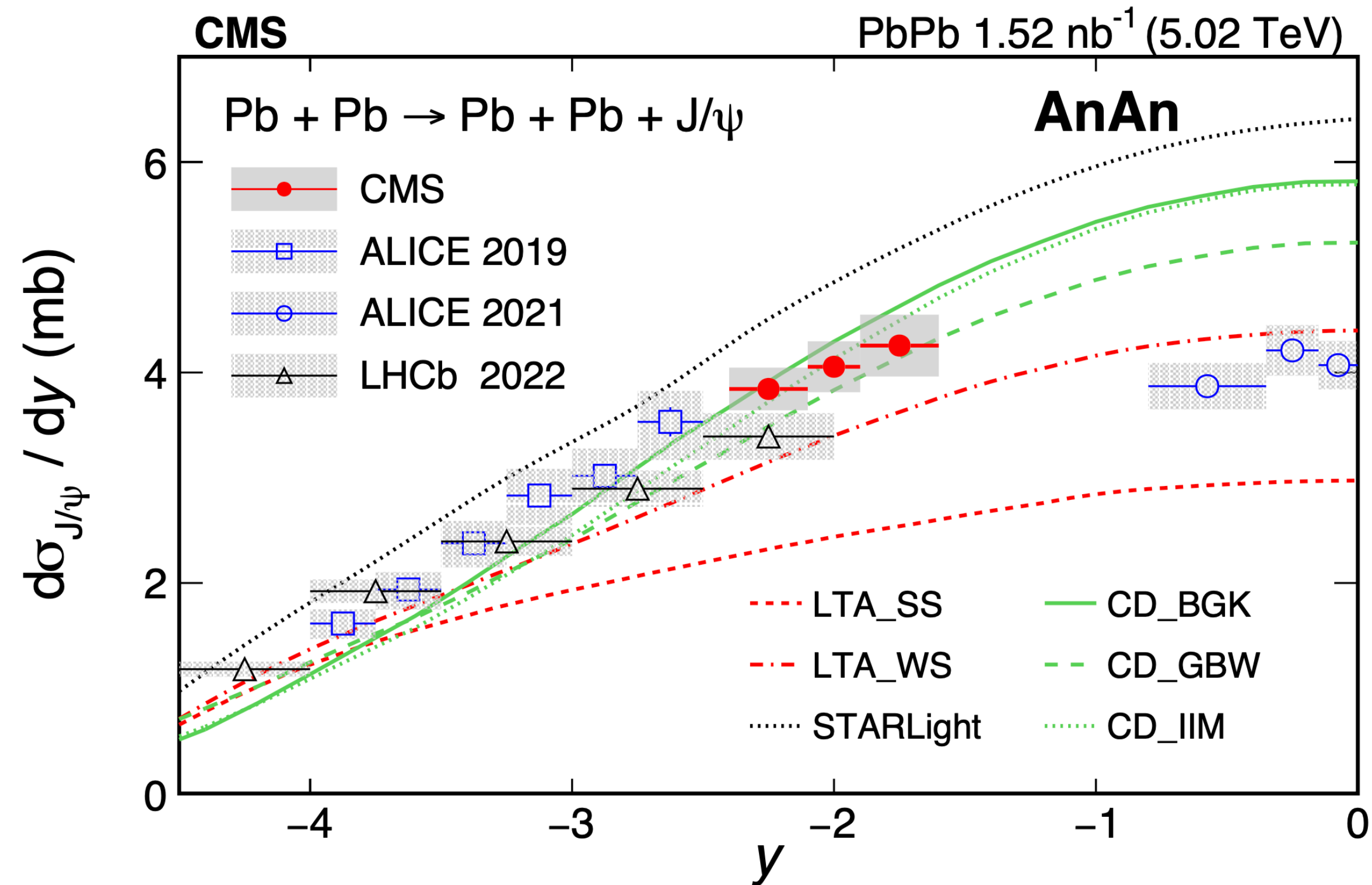

Imaging heavy nuclear with coherent J/ψ

ALICE, EPJC 81 (2021) 712
 CMS, PRL 131 (2023) 262301
 LHCb, JHEP 06 (2023) 146

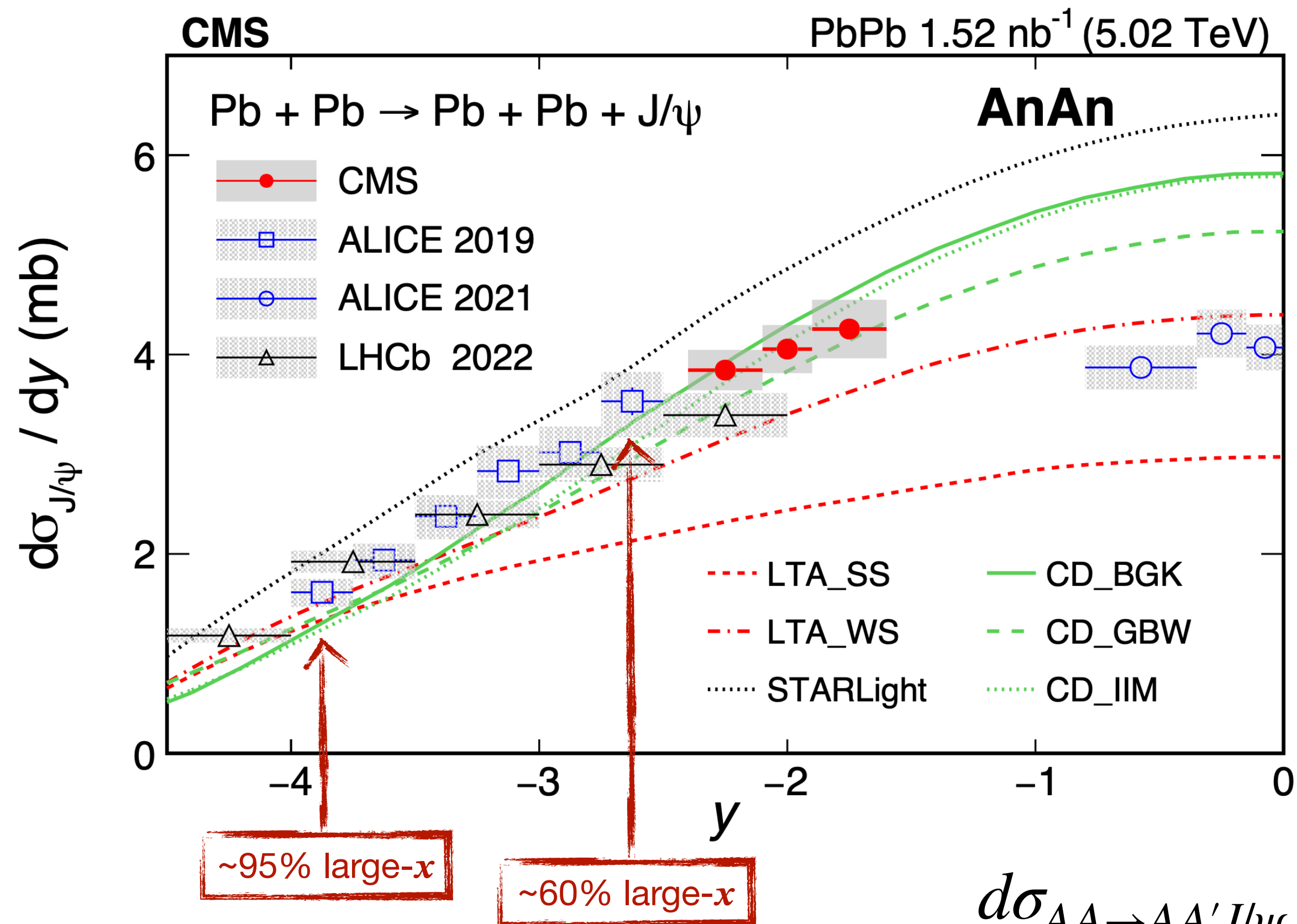

◉ LHC experiments complement each over a wide range of y region

• $R_g^{Pb} = 0.64 \pm 0.04$ at $x \sim 10^{-3}$ ($y=0$)

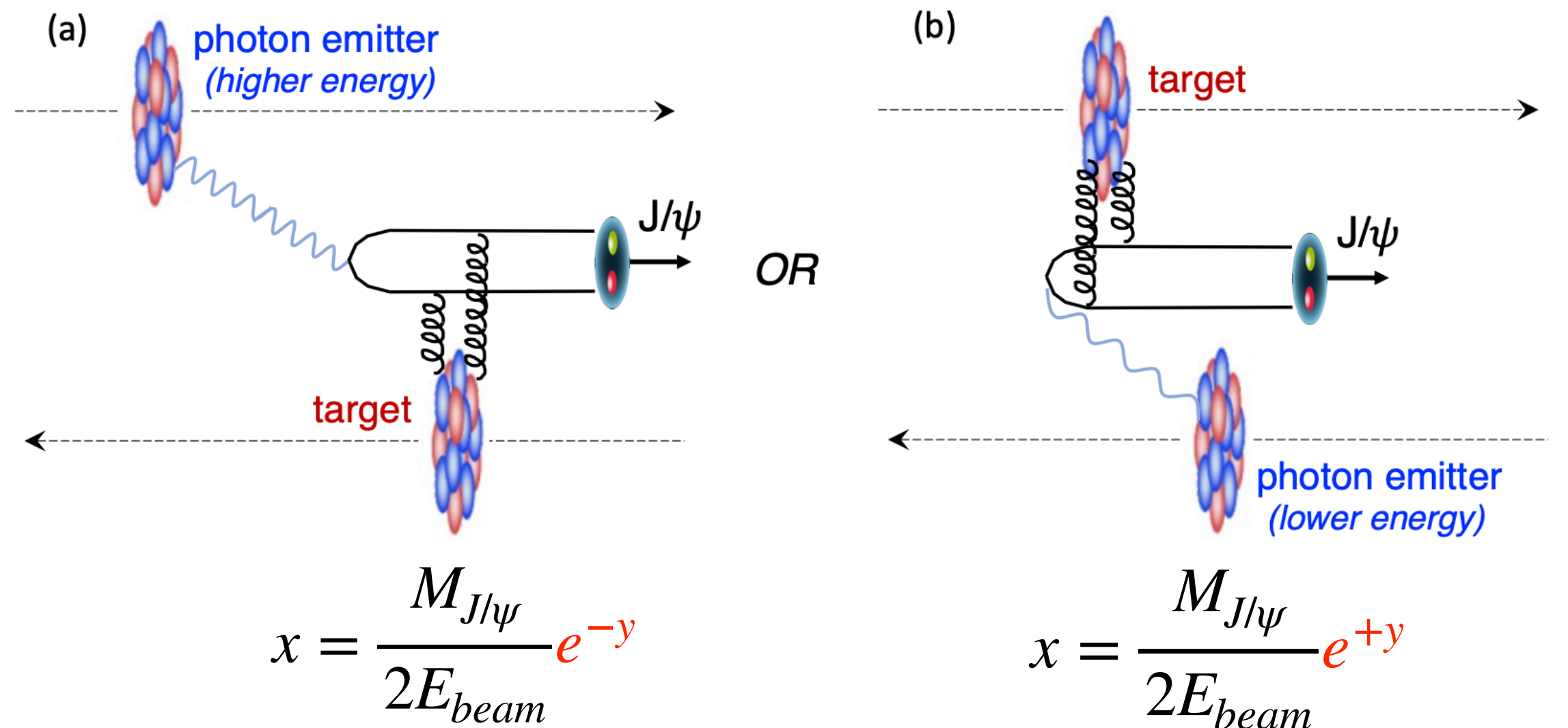

$$\frac{d\sigma_{AA \rightarrow AA' J/\psi}}{dy} = N_{\gamma/A}(\omega_1) \cdot \sigma_{\gamma A \rightarrow J/\psi A'}(\omega_1) + N_{\gamma/A}(\omega_2) \cdot \sigma_{\gamma A \rightarrow J/\psi A'}(\omega_2)$$

Imaging heavy nuclear with coherent J/ψ

CMS, PRL 131 (2023) 262301
ALICE, JHEP 10 (2023) 119

LO pQCD:
 $\sigma^{VM} \propto [xG(x)]^2$

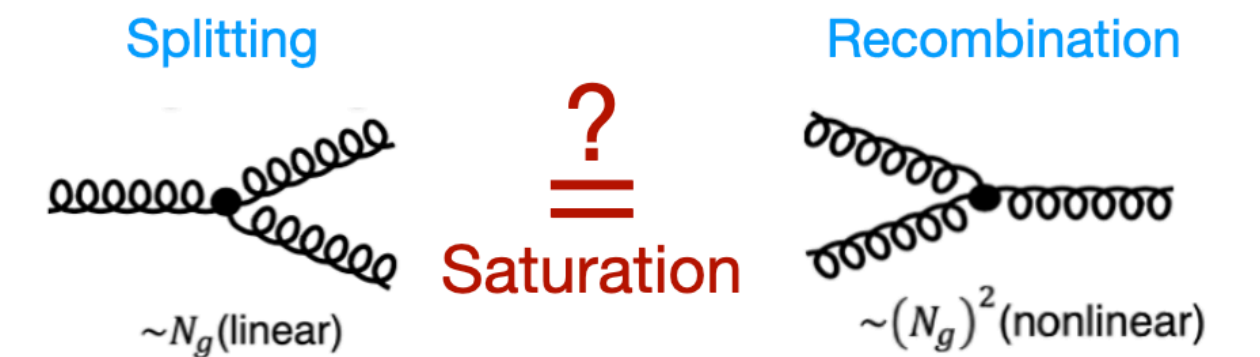
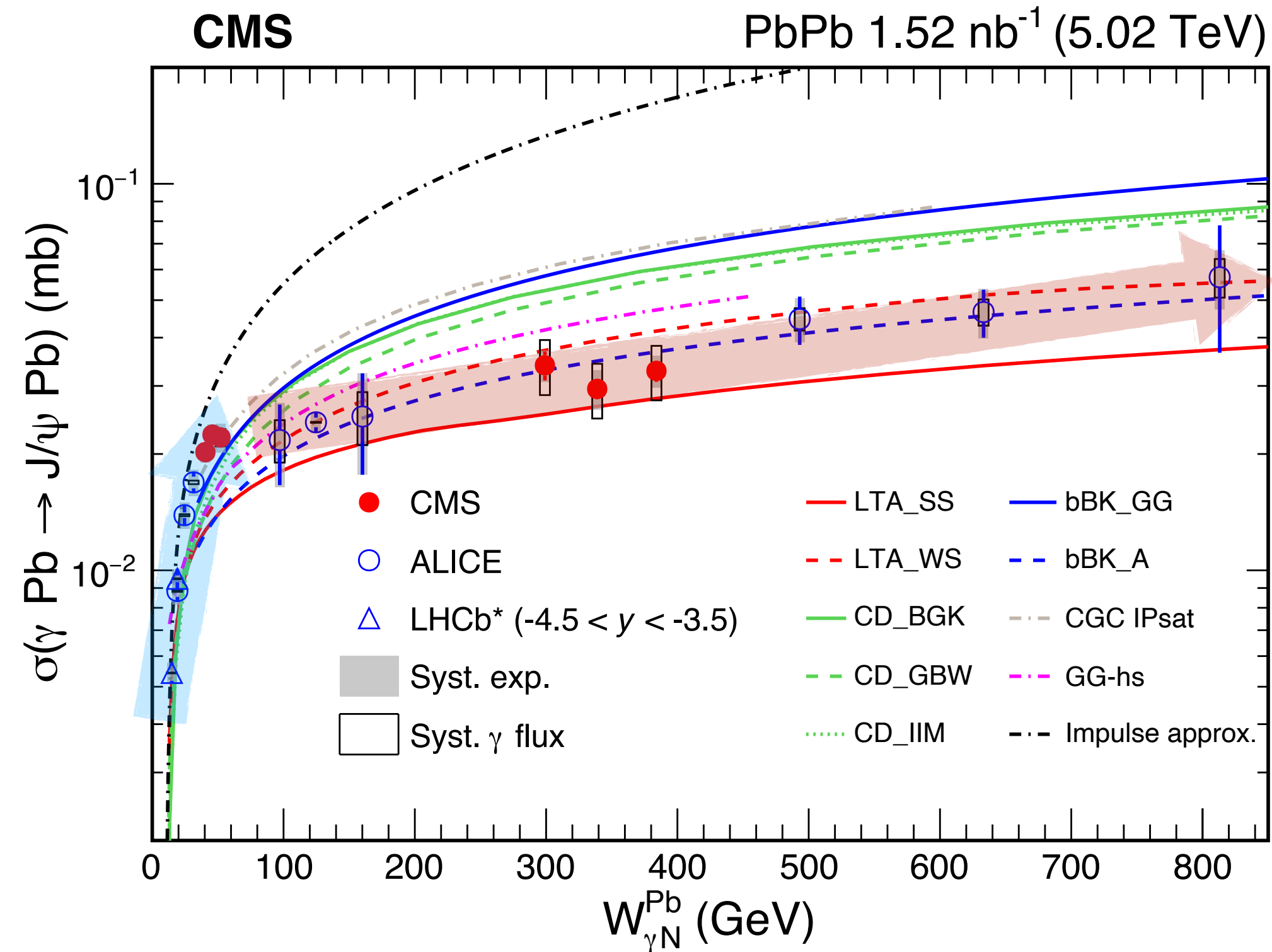

- ◉ Forward neutron tagging is employed to solve the “two-way” ambiguity
- ◉ Direct evidence of gluon saturation inside heavy nuclei?
 - $W_{\gamma N}^{Pb} < 40$ GeV: rapidly rising
 - $40 < W_{\gamma N}^{Pb} < 800$ GeV: nearly flat with a much slower rising

Incoherent J/ψ production at LHC

ALICE, PRL 132 (2024) 162302

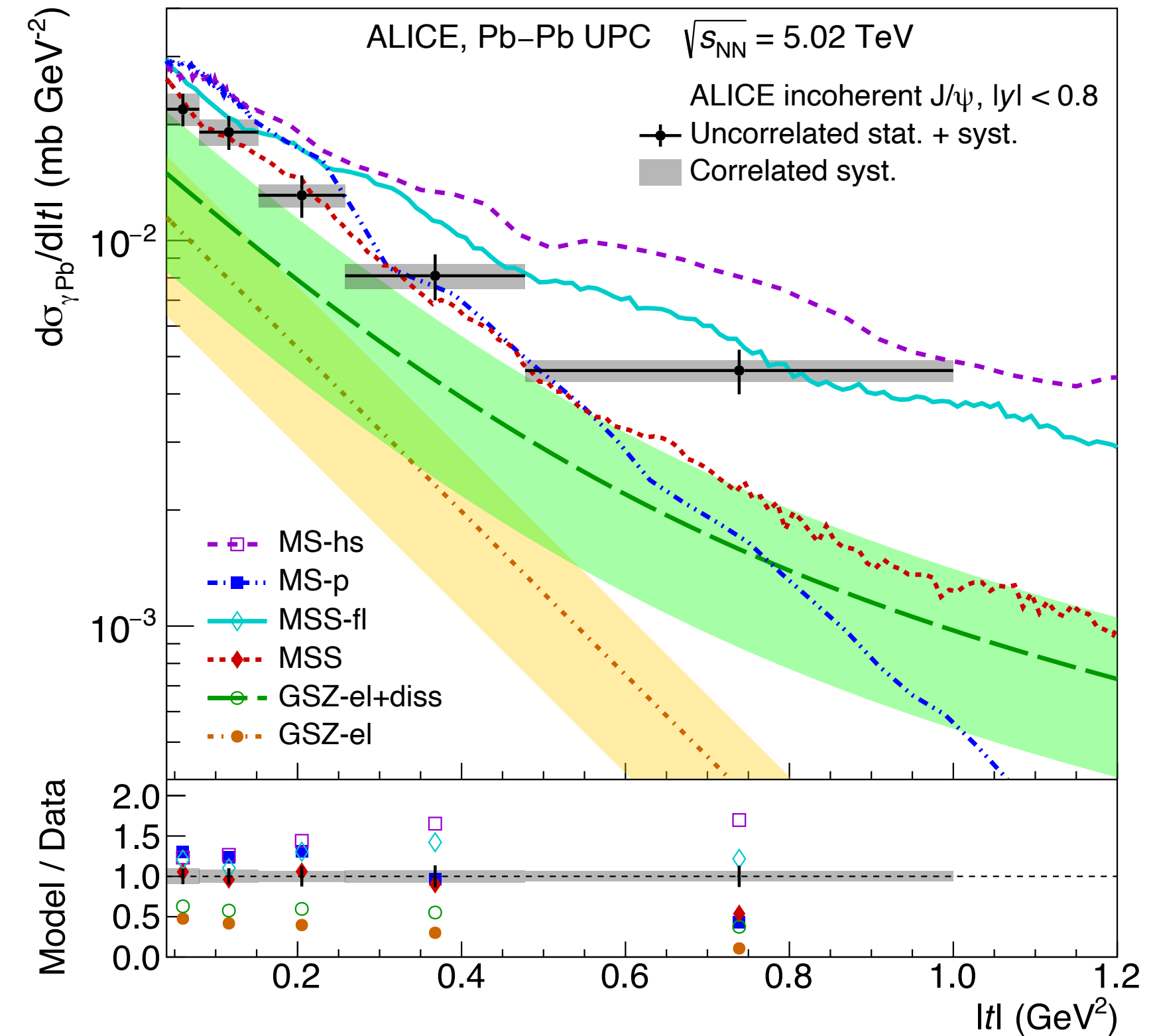
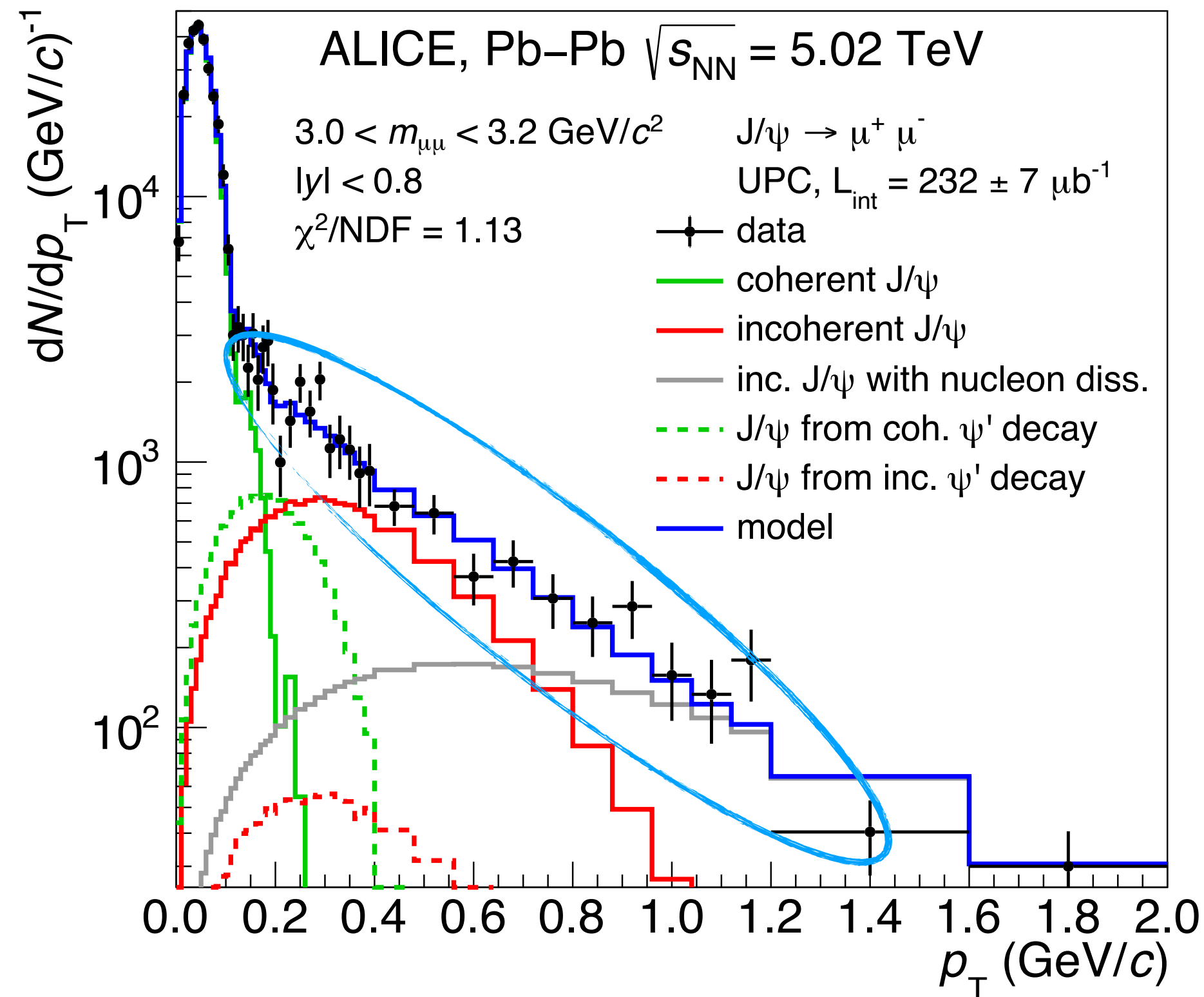

- ◎ The first measurement of $|t|$ spectrum of incoherent J/ψ
 - No model describes both the absolute yield and the shape of $|t|$ spectrum
 - A reasonably good description of the $|t|$ spectrum is achieved when models incorporate sub-nucleon fluctuation

Incoherent J/ψ production at RHIC

STAR, PRC 110 (2024) 14911

STAR, PRL 133 (2024) 523

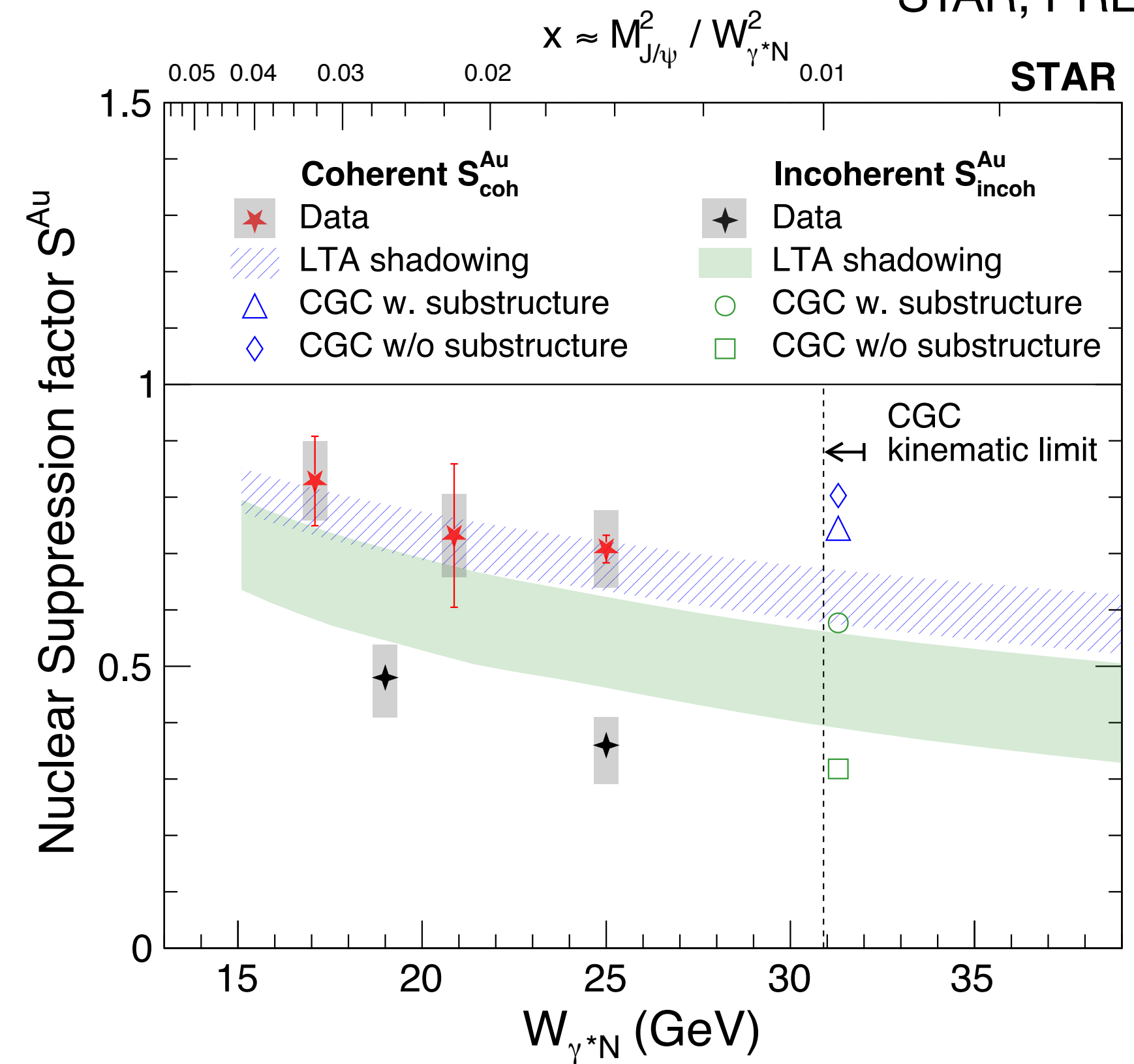
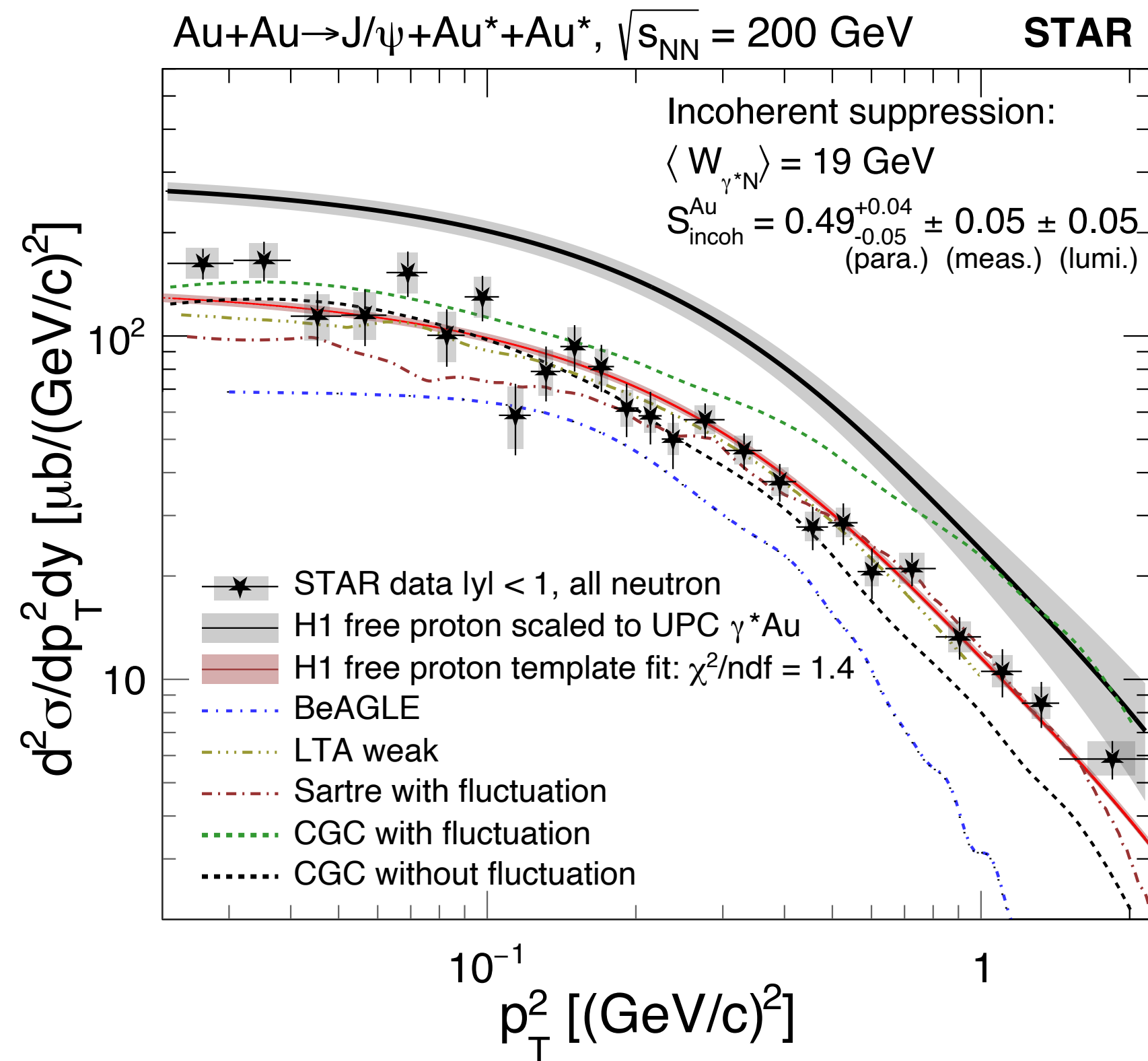

- The $|t|$ shapes of incoherent J/ψ are similar between bound and free nucleons
- The incoherent suppression factor is less than that of the coherent production
 - Cannot conclude if sub-nucleon fluctuation is present in the incoherent photoproduction

Spin-interference for photoproduced ρ^0

STAR, Sci. Adv. 9 (2023) eabq3903

$$\Delta\phi = \phi(\vec{e}^+ + \vec{e}^-) - \phi(\vec{e}^+ - \vec{e}^-)$$

Xing et al., JHEP 10 (2020) 064

Zha et al., PRD 103 (2021) 033007

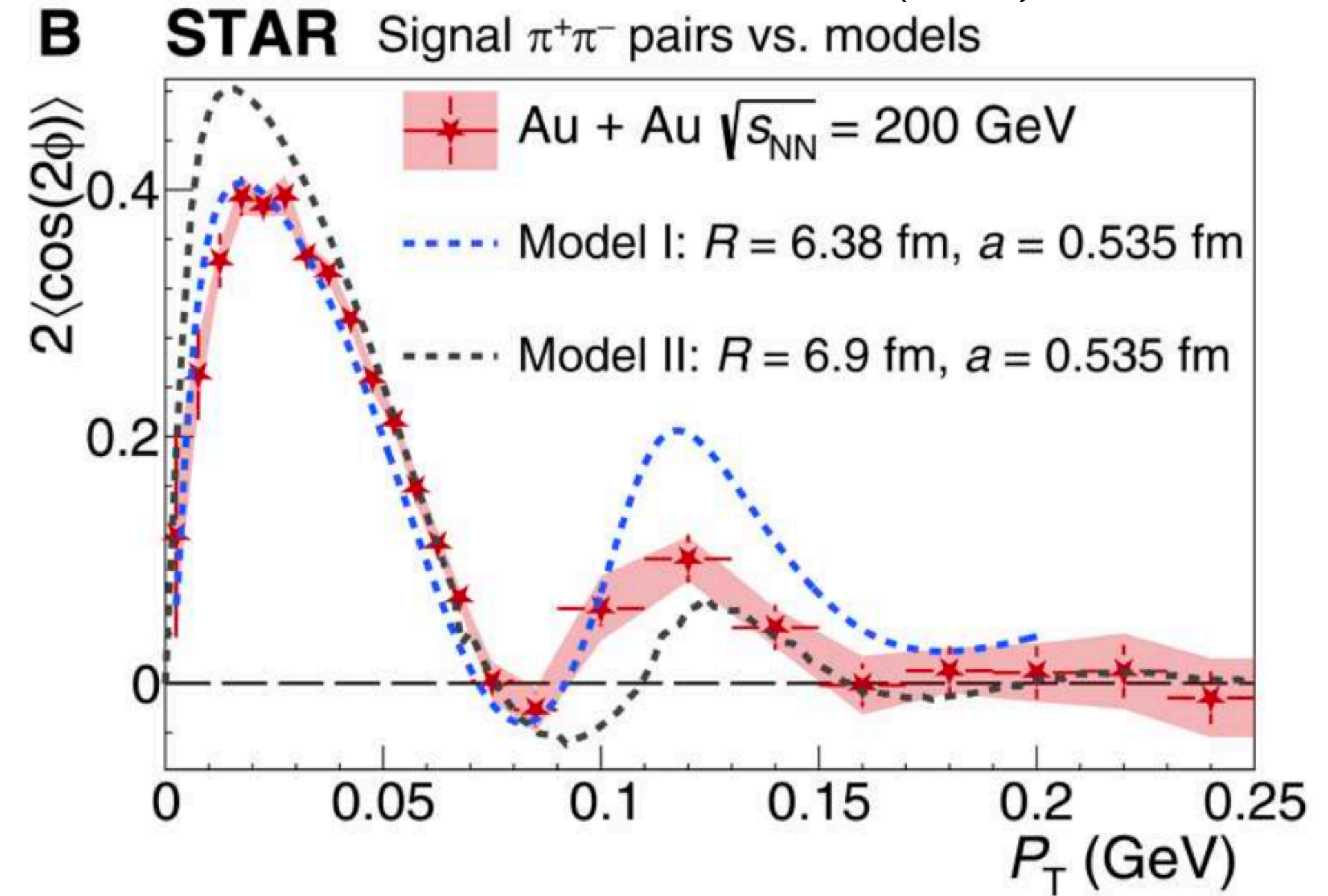
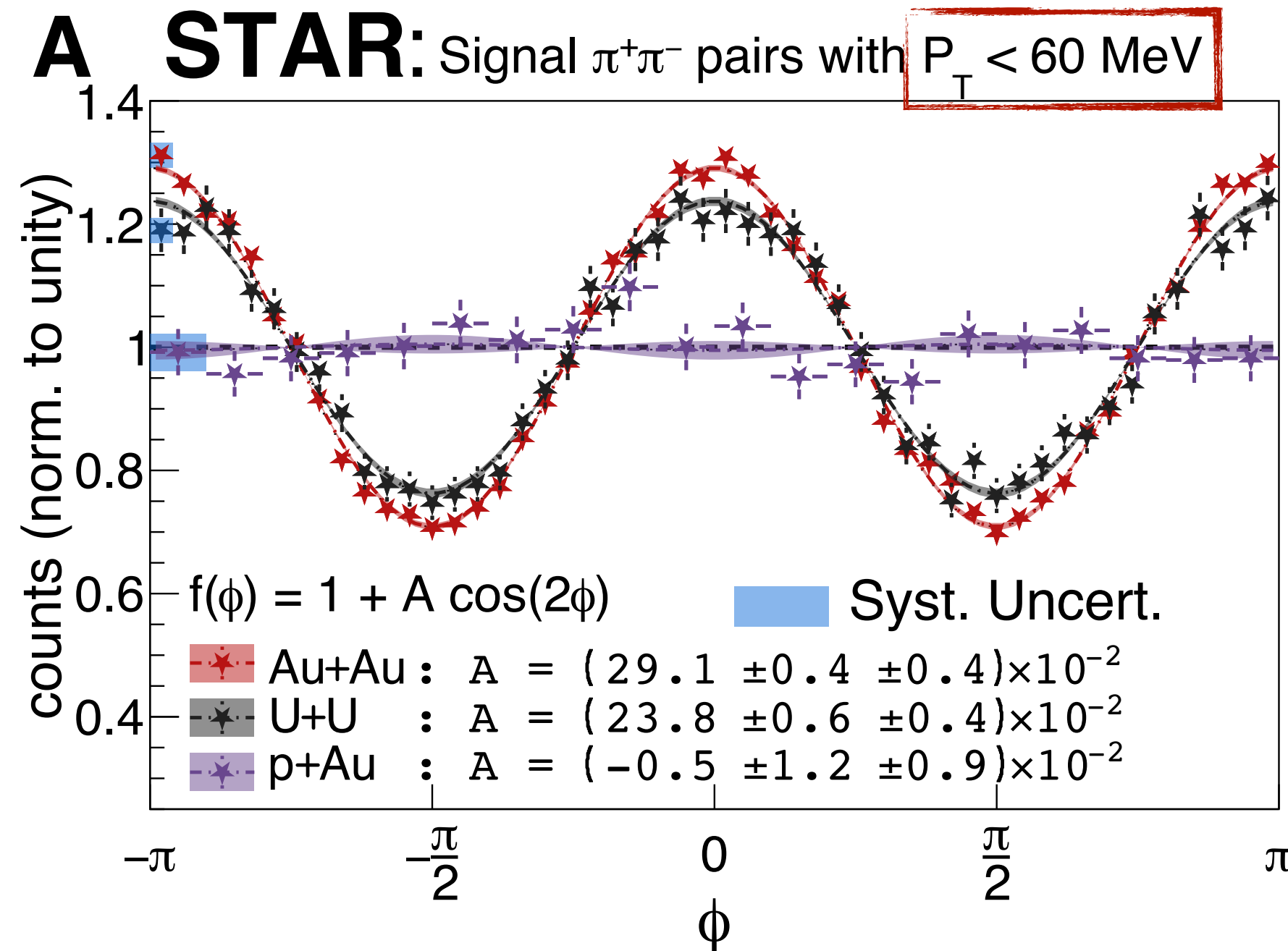
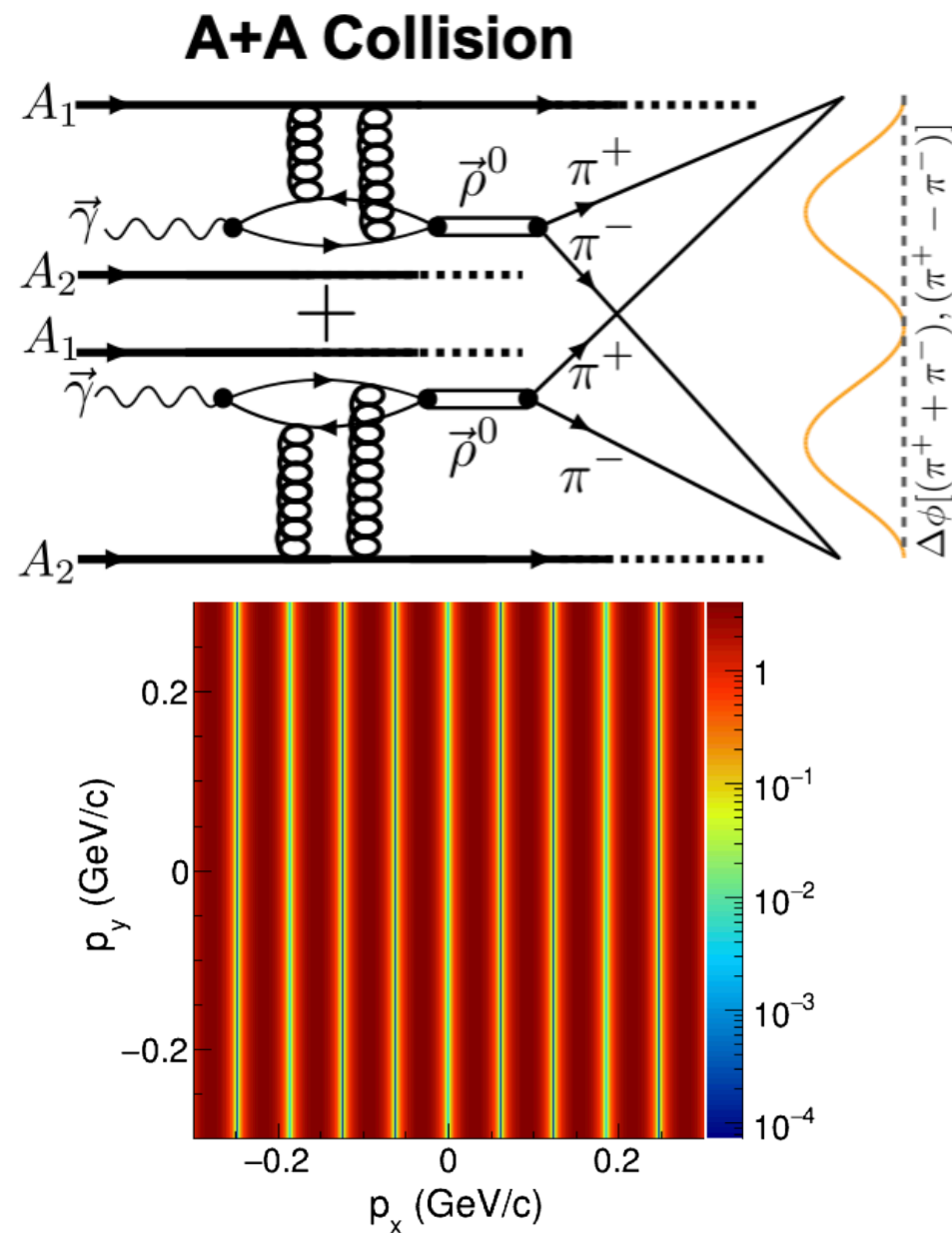

- Strong $\cos 2\Delta\phi$ modulations due to photon polarization
 - “Double-slit” interference is critical to this observable
- Sensitive to nuclear geometry \rightarrow strong interaction radius
 - New techniques for multidimensional imaging of nuclei

Spin-interference for photoproduced J/ψ

Zha et al., PRD 103 (2021) 033007

Brandenburg et al., PRD 106 (2022) 074008

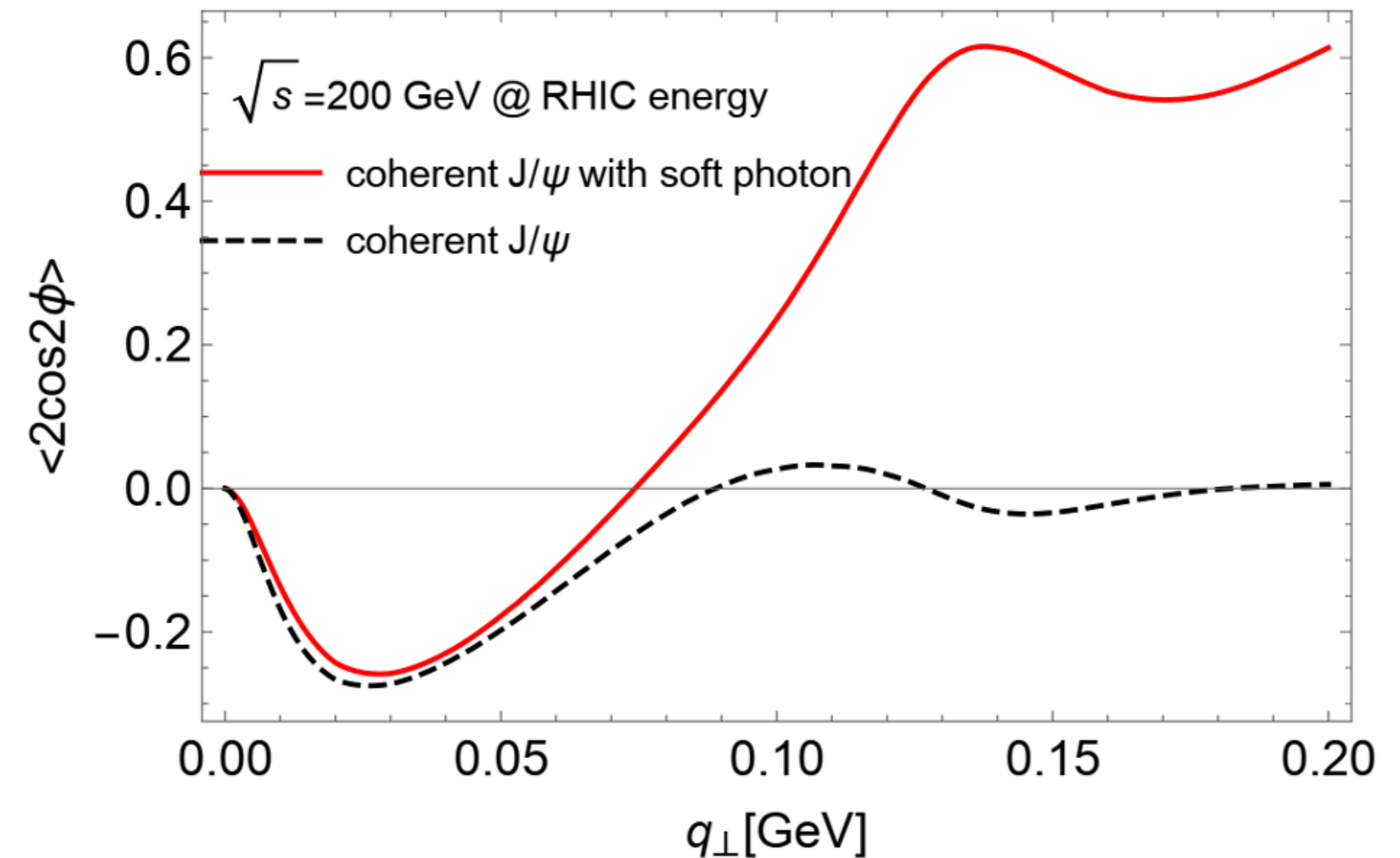
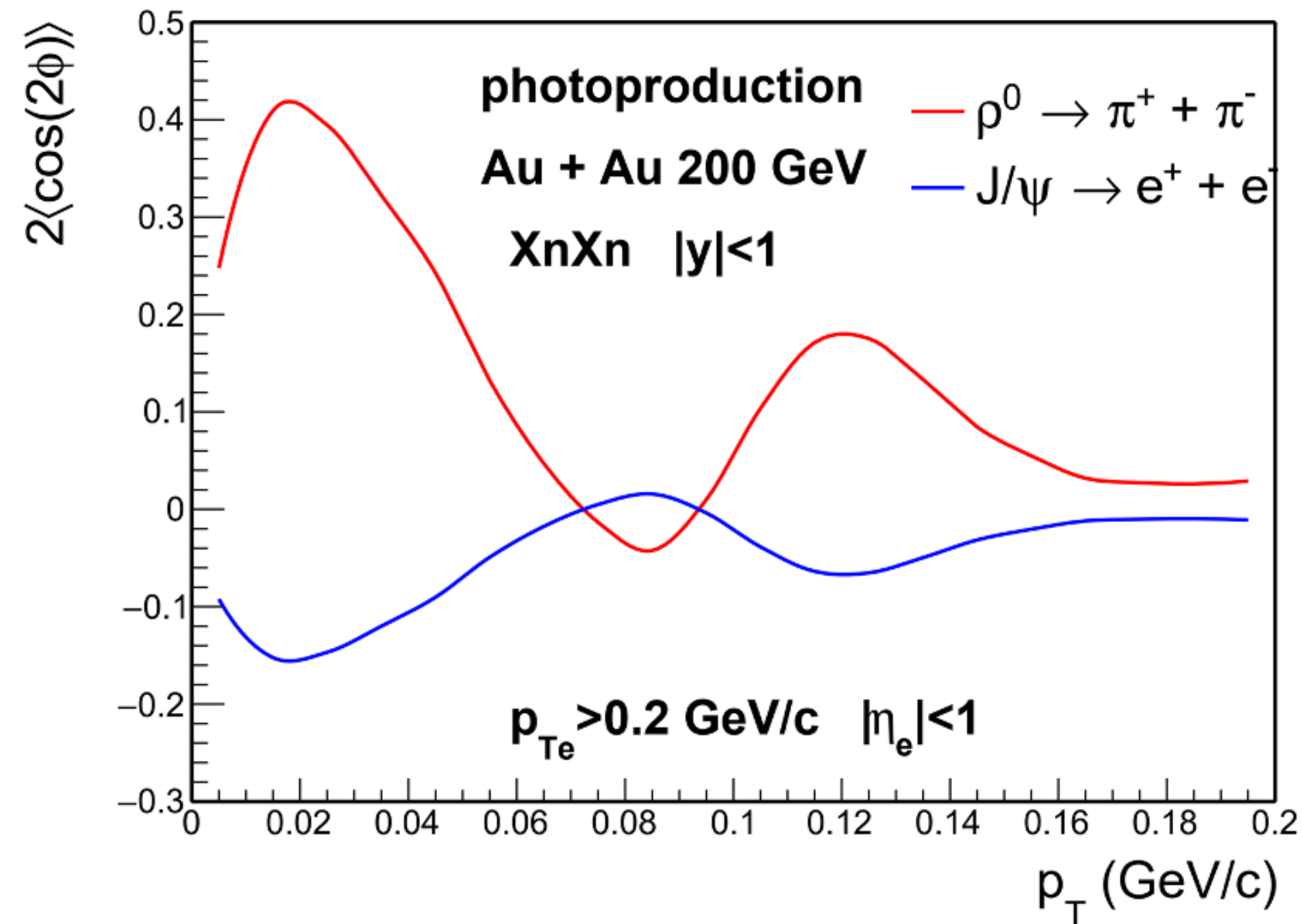

- ◉ Negative modulation predicted for J/ψ
 - Decay daughters are fermions \rightarrow different angular momentum projection along z-axis
- ◉ Need to consider the effect of soft photon radiation

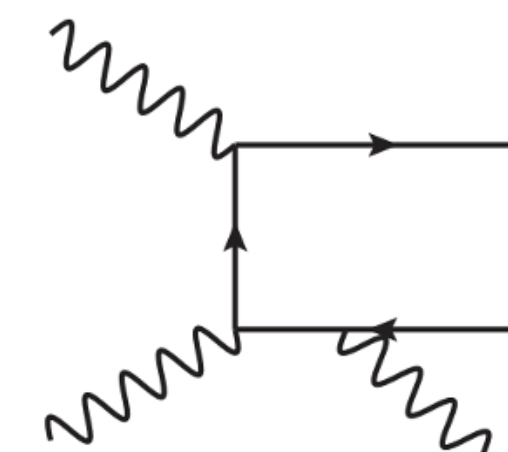

Spin-interference for photoproduced J/ψ

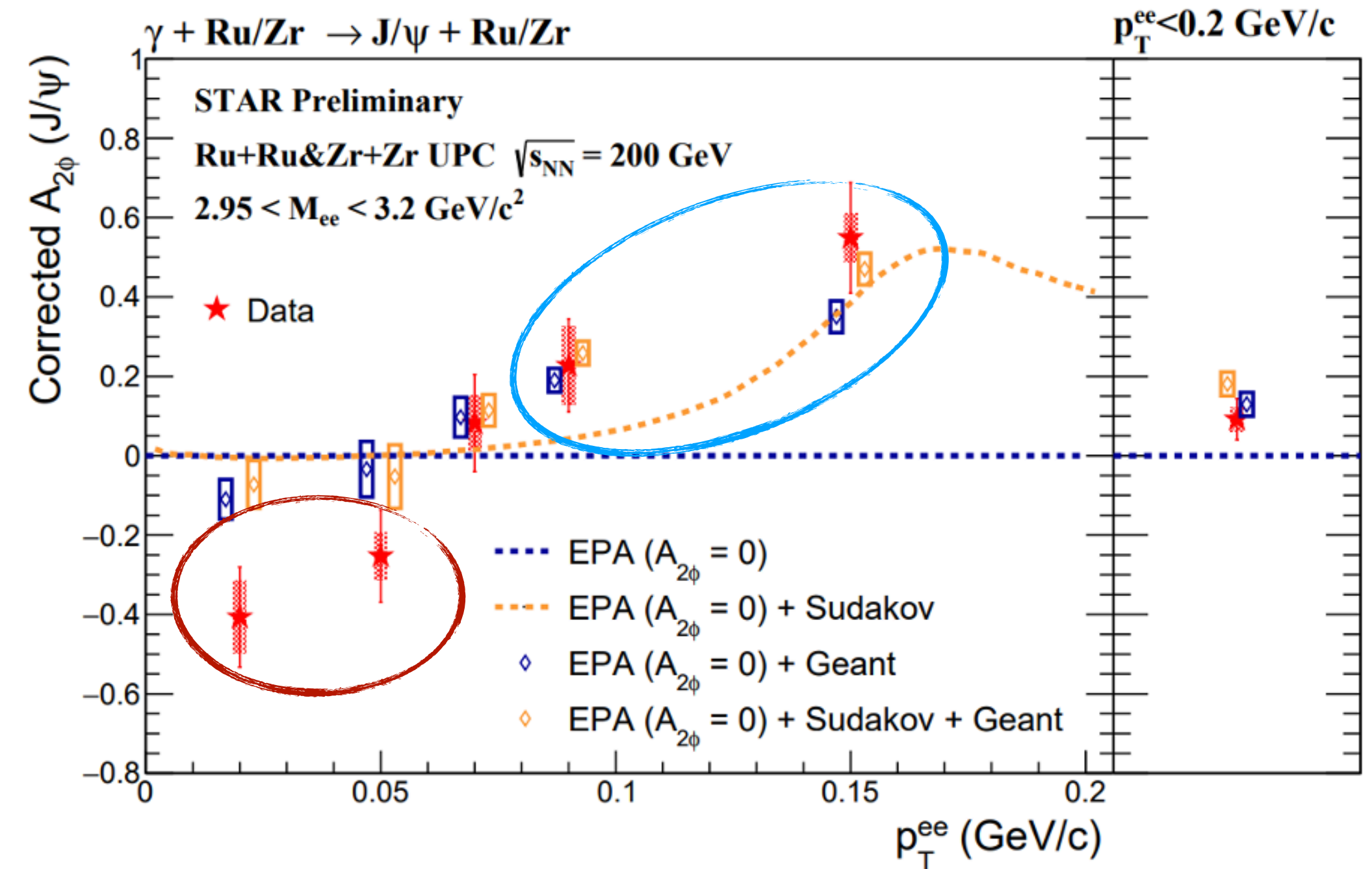
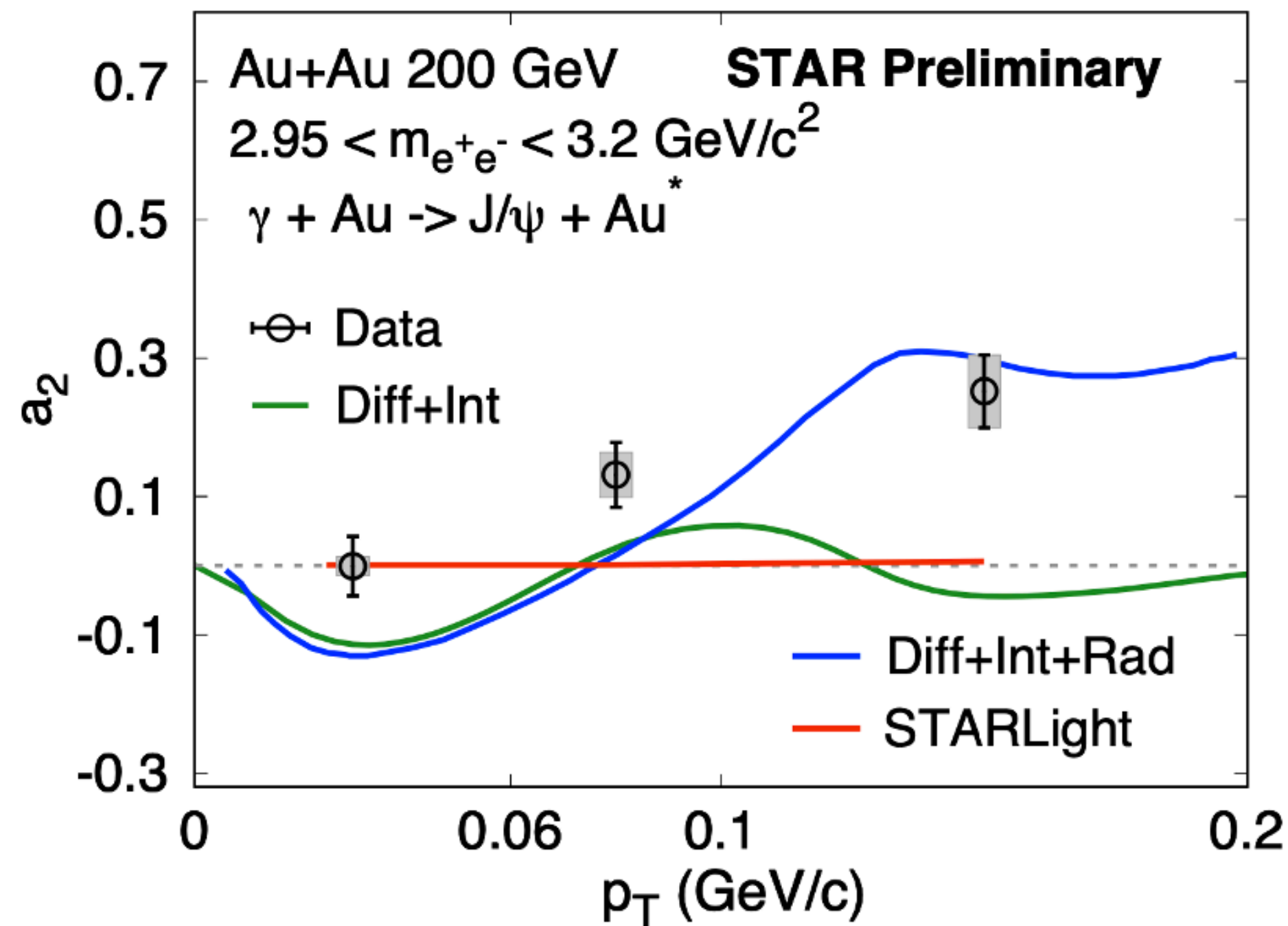

Experimental challenges of photoproduced J/ψ

- $\gamma\gamma \rightarrow e^+e^-$ background
- Soft photon radiation
- Bremsstrahlung & detector effects

Indication of negative spin interference of photoproduced J/ψ at low p_T

Summary

● Significant experimental progress of two-photon interactions

- Demonstrated the b -dependence of photon $p_T \rightarrow$ baseline to probe QGP EM effects
- Experimental signal of linearly polarized photon \rightarrow new techniques to image nuclear
- Observed $\gamma\gamma \rightarrow \tau\tau$ in UPC and showed the sensitivity to BSM physics
- Observed $\gamma\gamma \rightarrow p\bar{p}$ production \rightarrow higher excitation of QED vacuum

● Multidimensional imaging of nuclei with photon-nuclear interactions

- Direct experimental evidence of gluon saturation?
- Observed spin interference of photoproduced vector meson \rightarrow strong interactions radius
- First measurement of the $|t|$ -spectra of incoherent $J/\psi \rightarrow$ sub-nucleon fluctuation
- Observed Drell-Söding process?

Summary

● Significant experimental progress of two-photon interactions

- Demonstrated the b -dependence of photon $p_T \rightarrow$ baseline to probe QGP EM effects
- Experimental signal of linearly polarized photon \rightarrow new techniques to image nuclear
- Observed $\gamma\gamma \rightarrow \tau\tau$ in UPC and showed the sensitivity to BSM physics
- Observed $\gamma\gamma \rightarrow p\bar{p}$ production \rightarrow higher excitation of QED vacuum

● Multidimensional imaging of nuclei with photon-nuclear interactions

- Direct experimental evidence of gluon saturation?
- Observed spin interference of photoproduced vector meson \rightarrow strong interactions radius
- First measurement of the $|t|$ -spectra of incoherent $J/\psi \rightarrow$ sub-nucleon fluctuation
- Observed Drell-Söding process?

感谢大家聆听!

Backups

Energy dependence of $\gamma\gamma \rightarrow e^+e^-$ production

STAR, arXiv:2407.14821

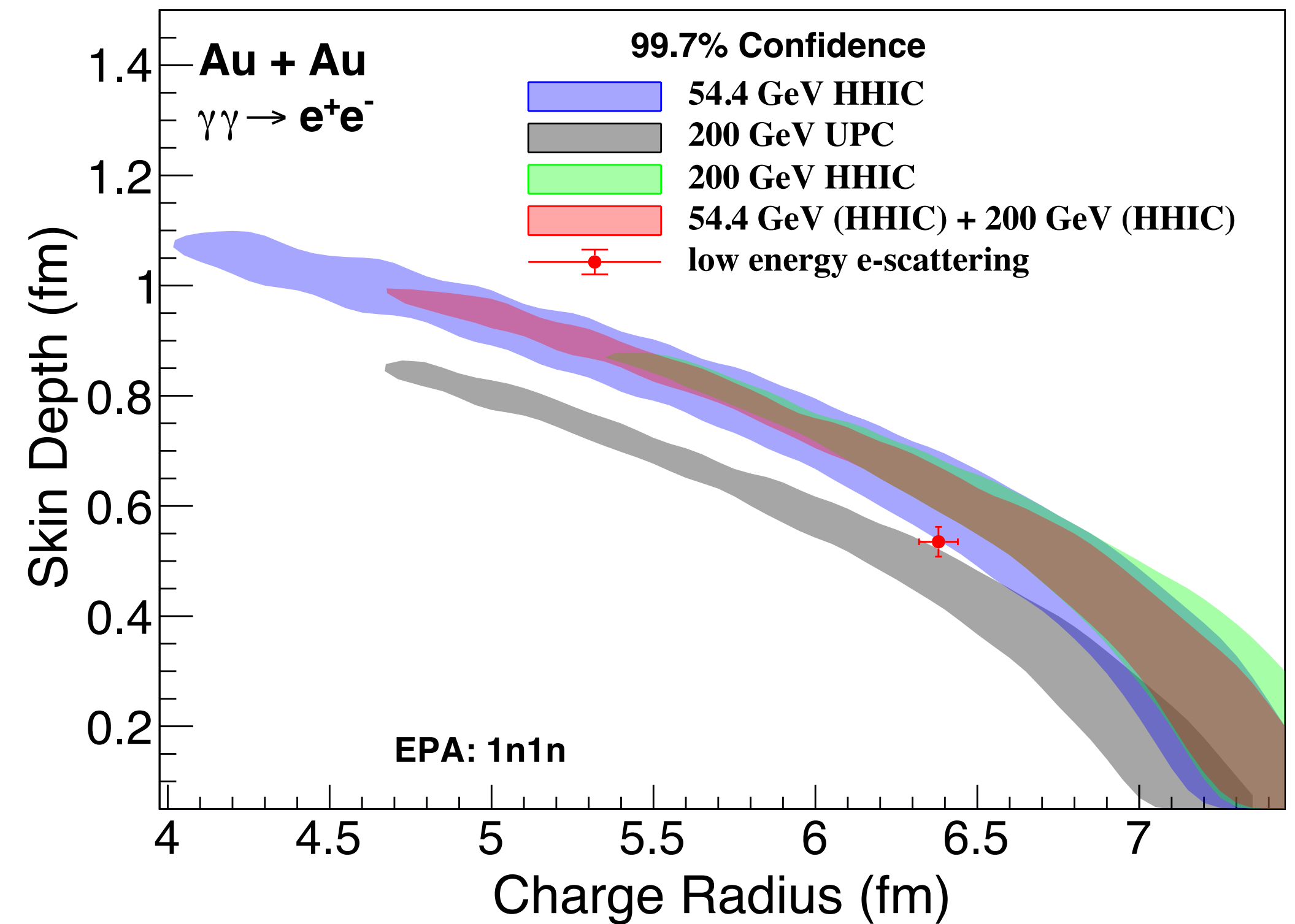
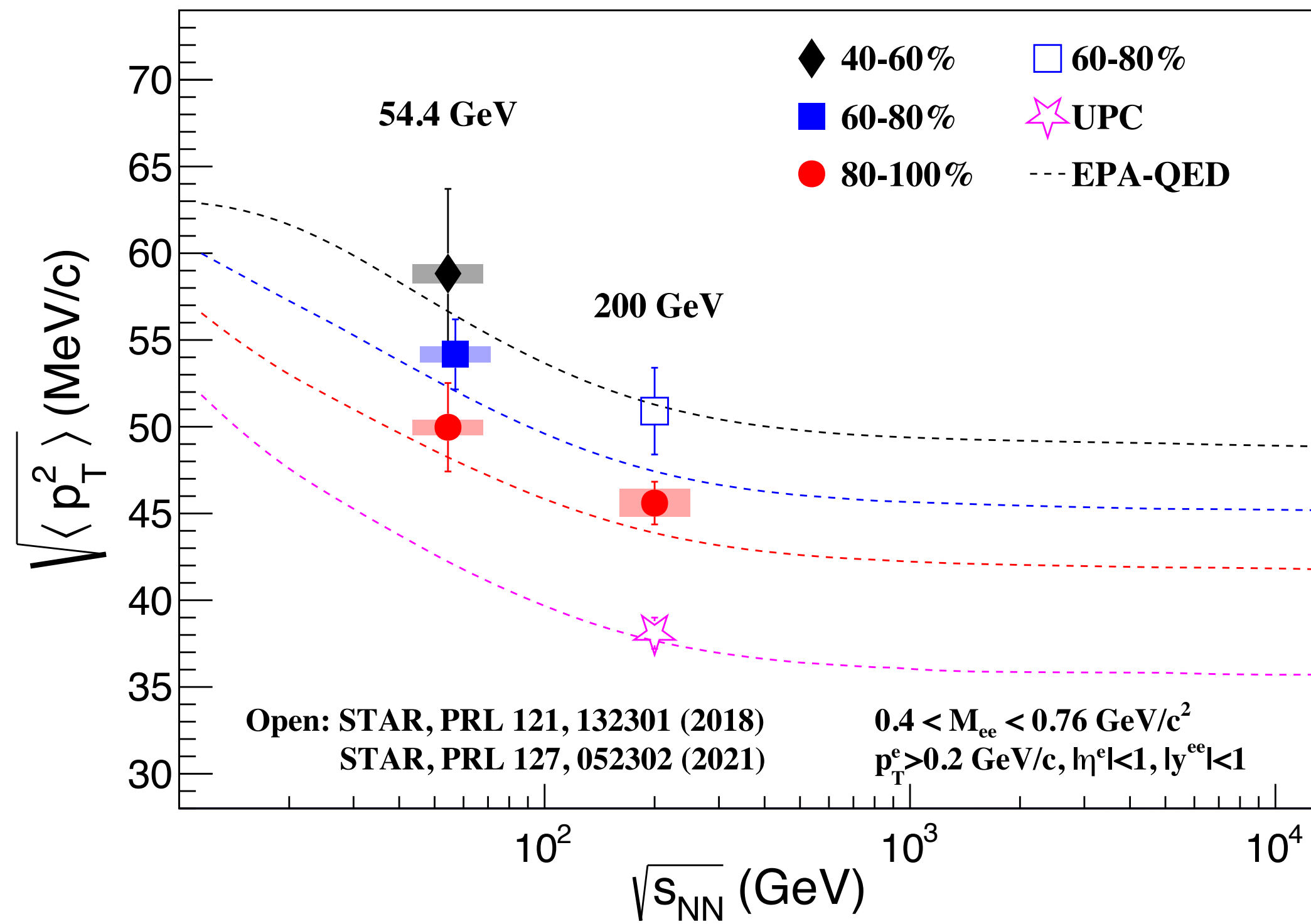

- ◎ Clear energy and centrality (b) dependence of $\gamma\gamma \rightarrow e^+e^-$ production
 - Consistent with EPA-QED baseline
- ◎ Constrain the nuclear charge distribution with $\gamma\gamma \rightarrow e^+e^-$ production

Control impact parameter in UPC

Nuclei **may** exchange soft photon(s) \Rightarrow **nuclear dissociation**

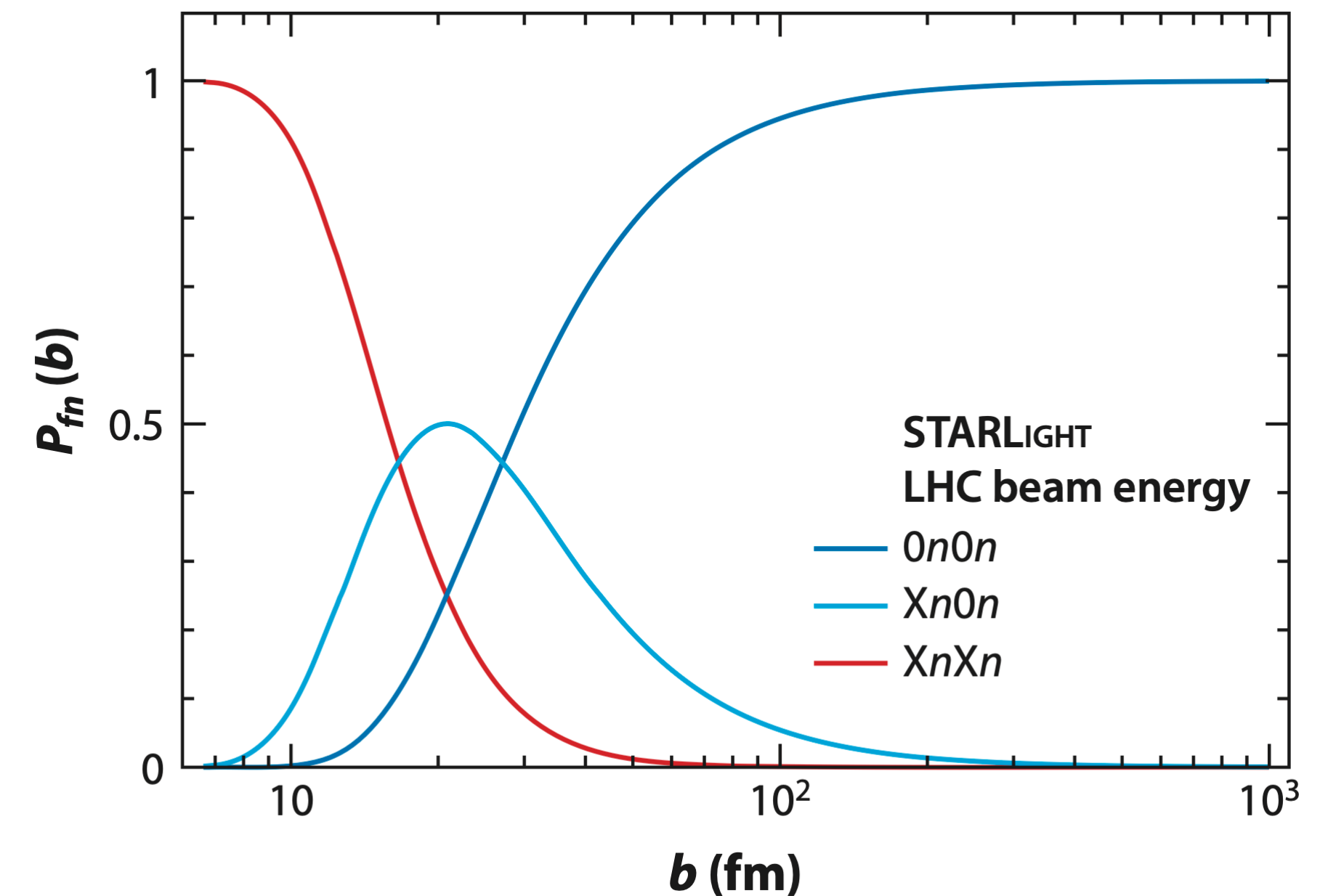
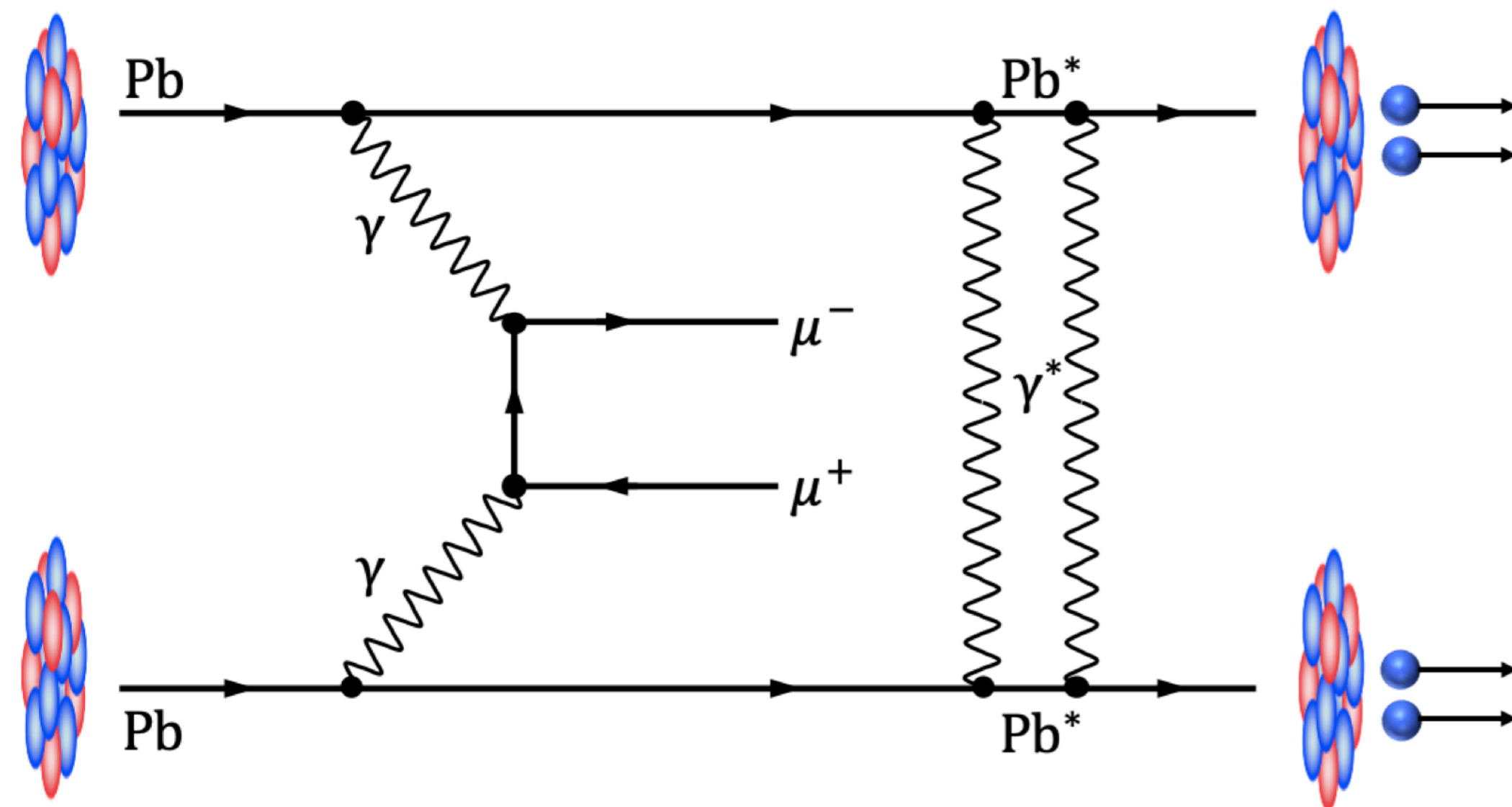

Klein and Steinberg, Ann. Rev. Nucl. Part. Sci. 70 (2020) 323

◎ **Control the impact parameter via forward neutron multiplicity**

- $b_{XnXn} < b_{0nXn} < b_{0n0n}$

A solution to the “two-way ambiguity”

CMS, PRL 127 (2021) 122001

Guzey et al., EPJC 74 (2014) 2942

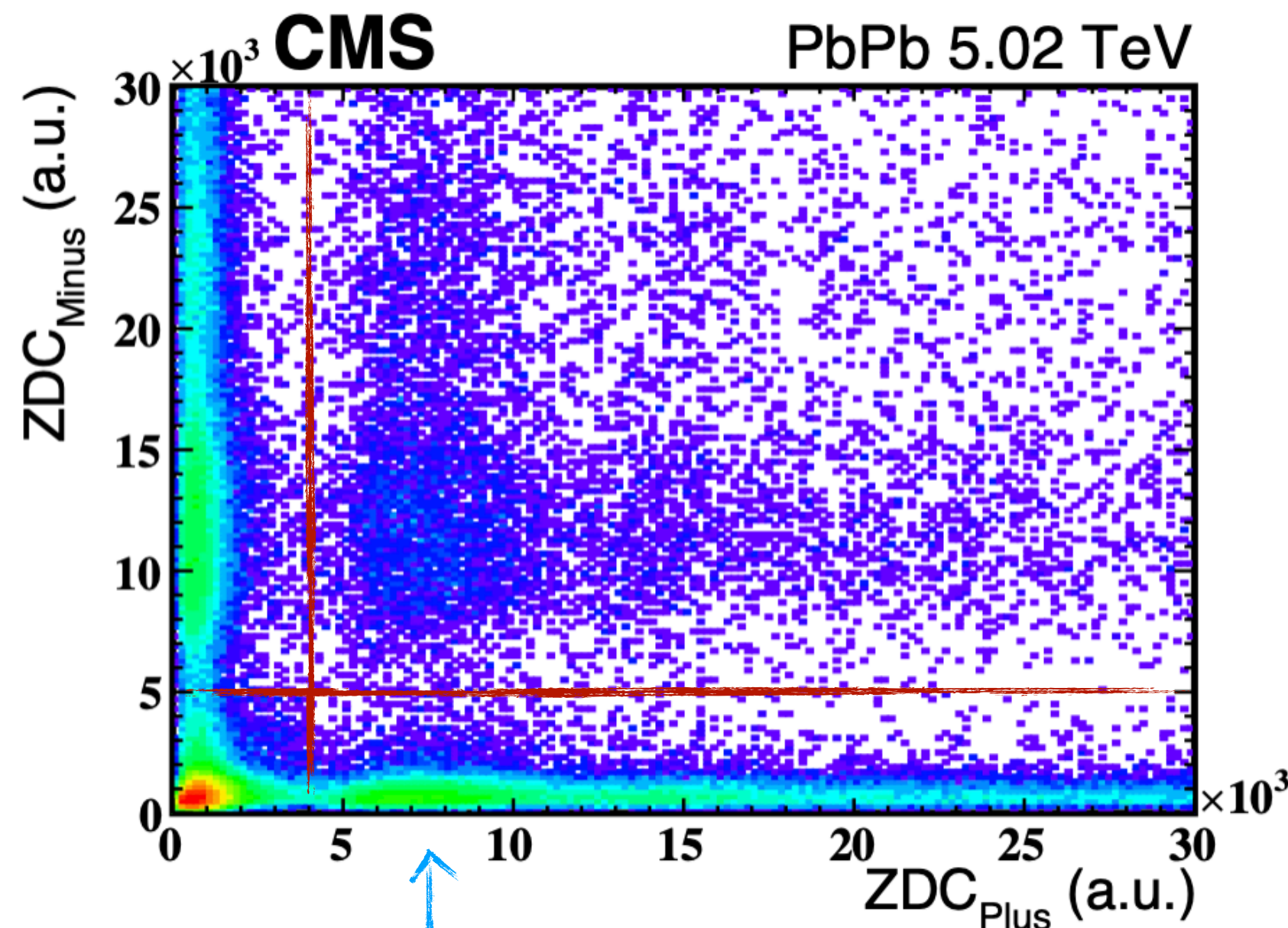

Single neutron peak

Experimental measurements

$$\frac{d\sigma_{AA \rightarrow AA' J/\psi}^{0n0n}}{dy} = N_{\gamma/A}^{0n0n}(\omega_1) \cdot \sigma_{\gamma A \rightarrow J/\psi A'}(\omega_1) + N_{\gamma/A}^{0n0n}(\omega_2) \cdot \sigma_{\gamma A \rightarrow J/\psi A'}(\omega_2)$$

$$\frac{d\sigma_{AA \rightarrow AA' J/\psi}^{0nXn}}{dy} = N_{\gamma/A}^{0nXn}(\omega_1) \cdot \sigma_{\gamma A \rightarrow J/\psi A'}(\omega_1) + N_{\gamma/A}^{0nXn}(\omega_2) \cdot \sigma_{\gamma A \rightarrow J/\psi A'}(\omega_2)$$

$$\frac{d\sigma_{AA \rightarrow AA' J/\psi}^{XnXn}}{dy} = N_{\gamma/A}^{XnXn}(\omega_1) \cdot \sigma_{\gamma A \rightarrow J/\psi A'}(\omega_1) + N_{\gamma/A}^{XnXn}(\omega_2) \cdot \sigma_{\gamma A \rightarrow J/\psi A'}(\omega_2)$$

Photon flux from theory

What we need!

Solve the “two-way ambiguity”

Probe gluons at $x \sim 10^{-5} - 10^{-4}$ in heavy nucleus!

Coherent J/ψ production vs. $W_{\gamma N}^{Pb}$

ALICE, JHEP 10 (2023) 119
 ALICE, EPJC 81 (2021) 712
 ALICE, PLB 798 (2019) 134926

CMS, PRL 131 (2023) 262301
 LHCb, JHEP 06 (2023) 146

ALICE, EPJC 79 (2019) 402

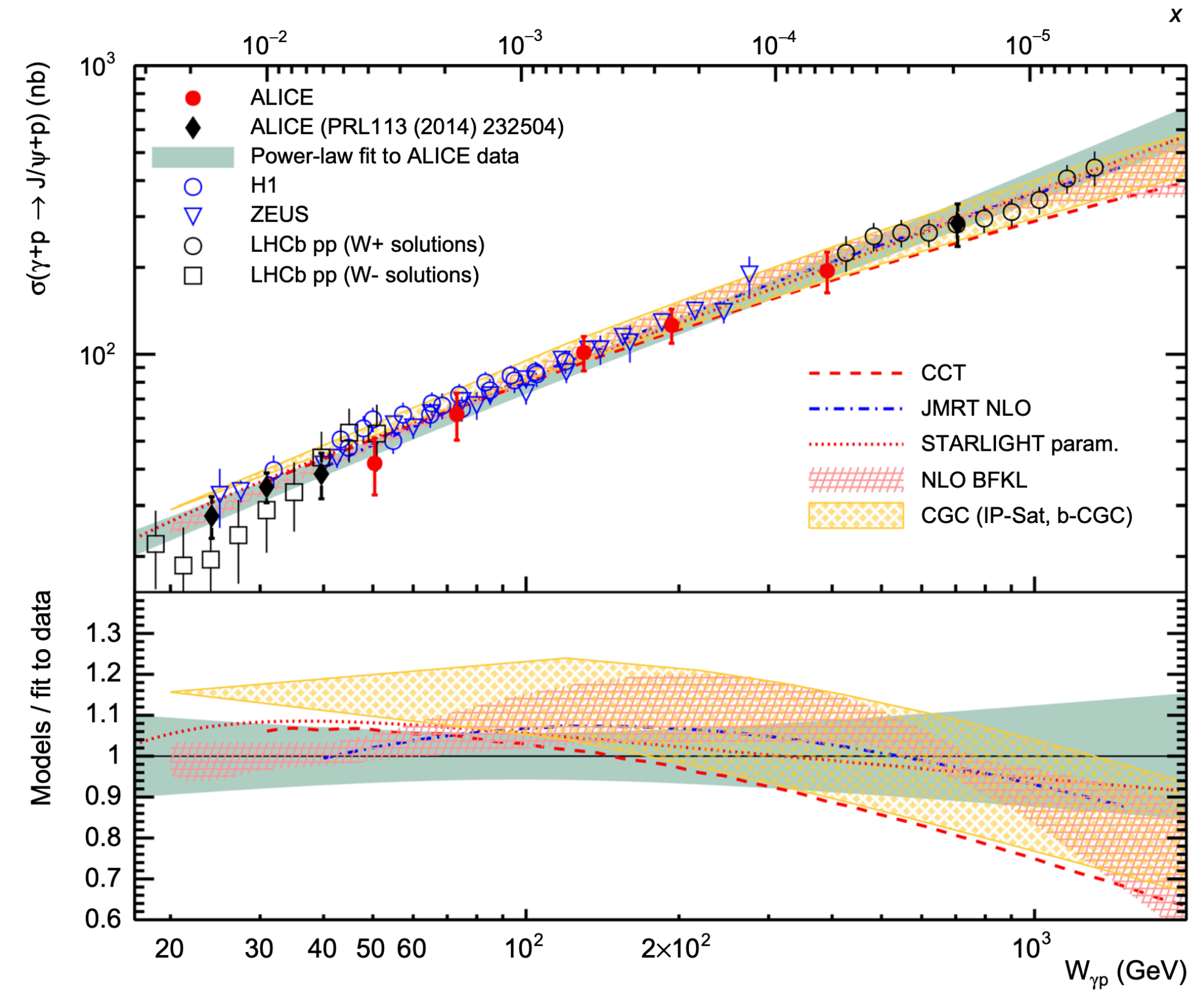
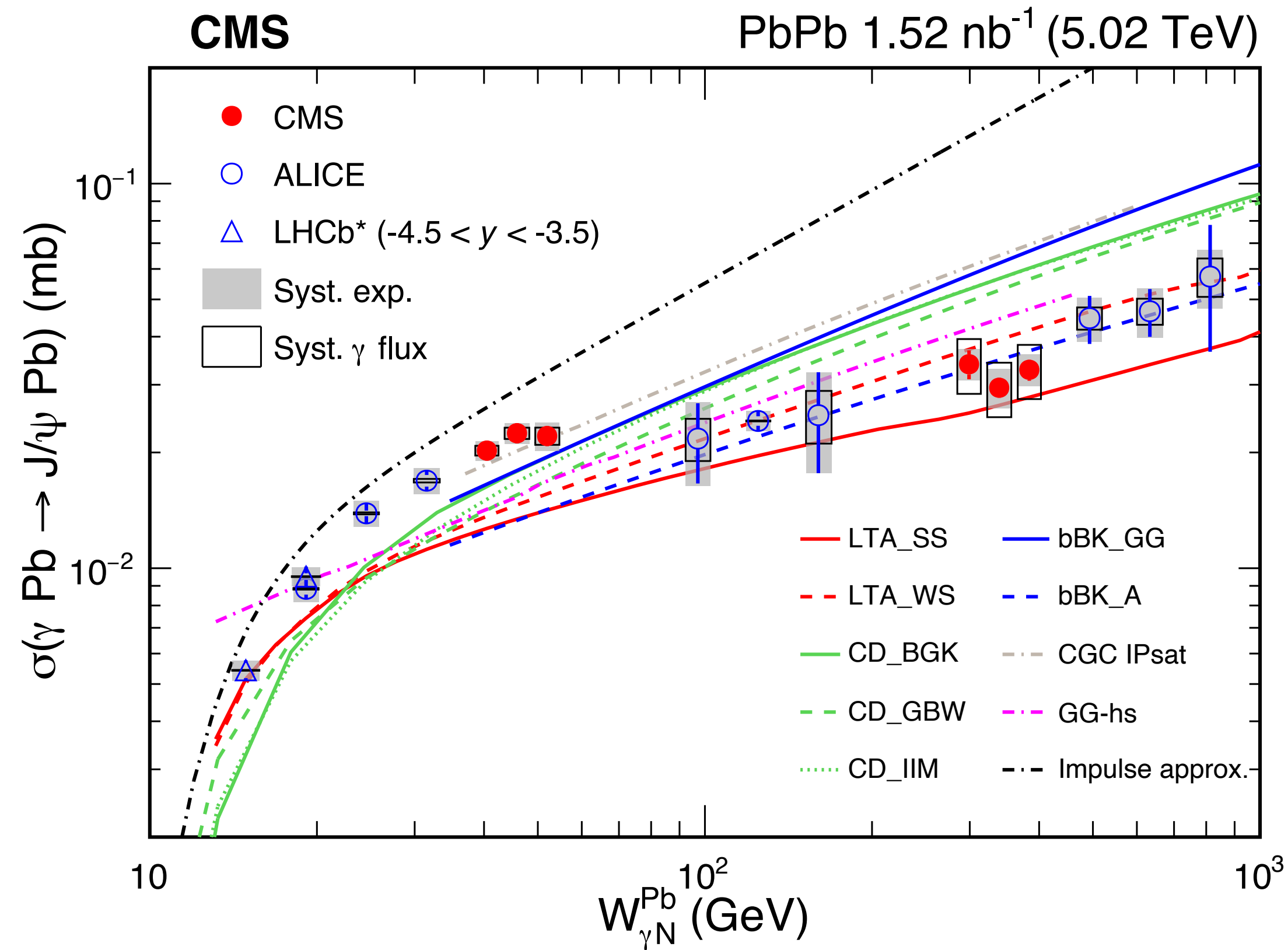

$$\gamma A \rightarrow J/\psi A$$

$$\gamma p \rightarrow J/\psi p$$