

Mechanical Design of the CEPC Vertex Detector

Jinyu Fu
2024-5-22

Layout - long barrel

The VTX - section view

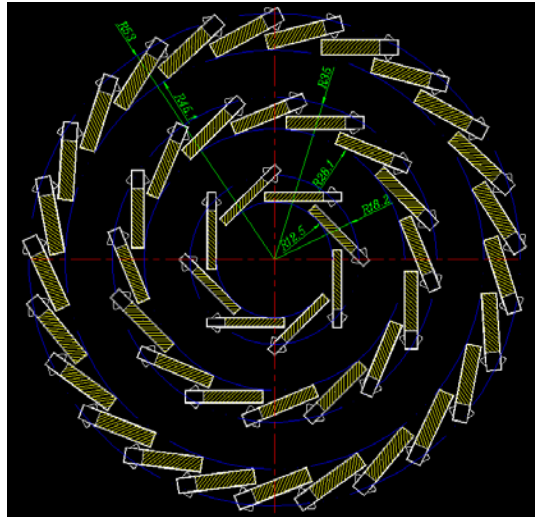

Three different sizes of ladders(section size and length) for barrels.

Ladder support size

layer	Size .mm (W x H x L mm)
inner	17.4x1.7x260
middle	17.4x2.5x486
outer	17.4x3.2 x749

The VTX - side view

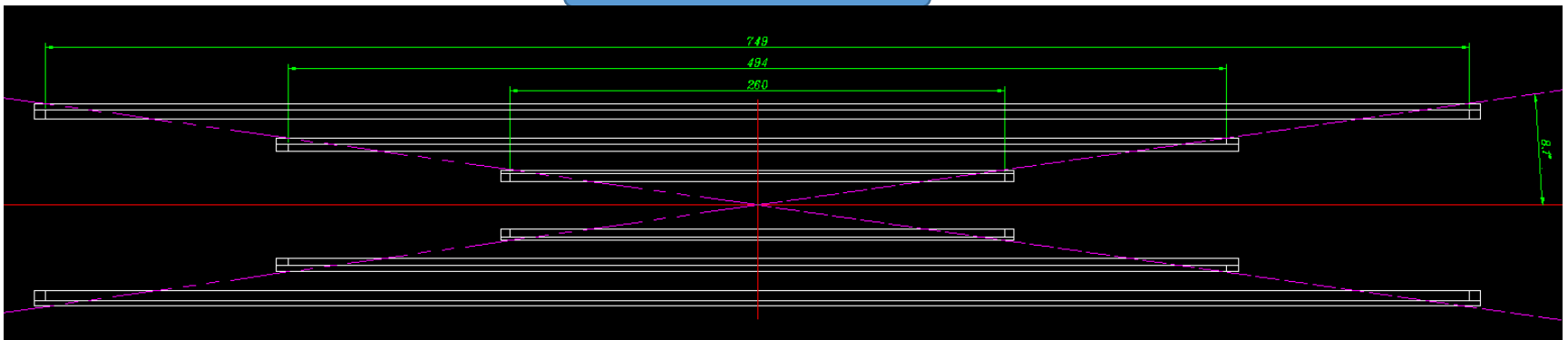

Ladder and ladder support

Ladder components are similar to most2 prototype

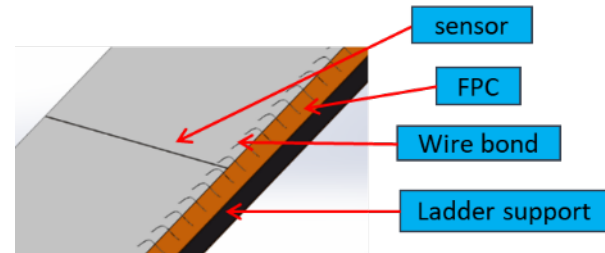
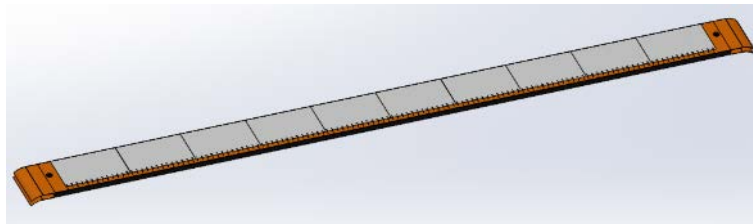

The max length of the ladder support is ~ 750 mm, about 3 times of that we made for the prototype.

The doable new sections design of such long CFRP ladder support (compared and confirmed):

- material selection - CFRP
- 4 to 5 layers of plies with the maximum thickness of 0.15 mm

VTX assembly

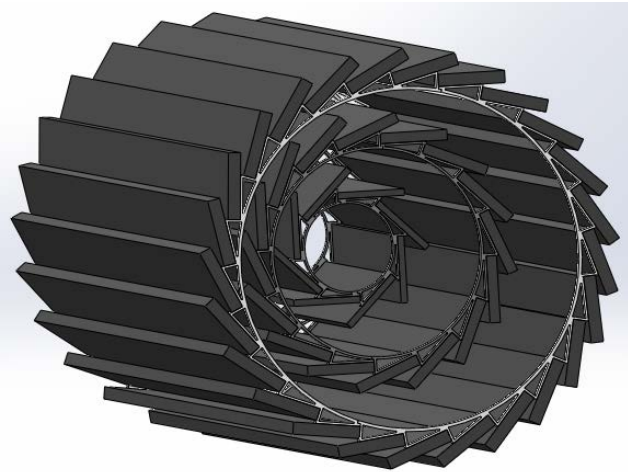

Support rings / Al alloy

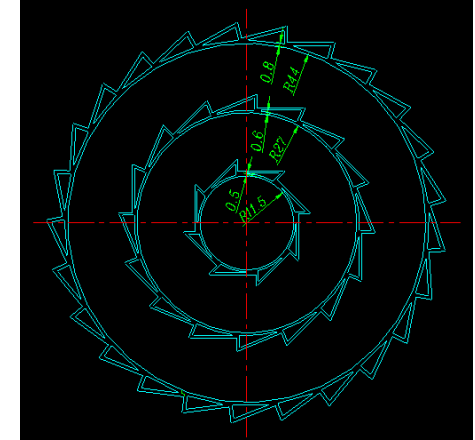
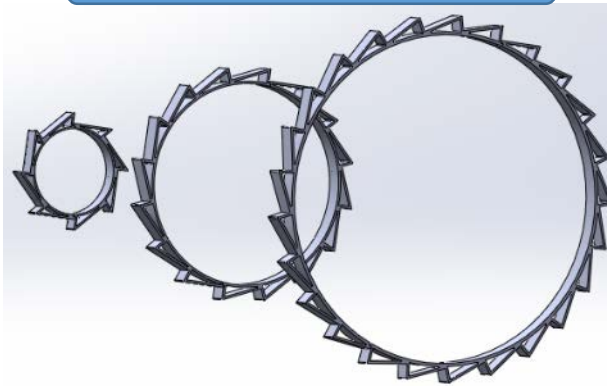

Ladder can be glued / bolted to the support ring. Gluing will save space to make the ratchet teeth hollow, which helps ventilation, currently we prefer this method.

Two methods to assemble the VTX:

- Assemble the barrel in advance (consisting of two halves), then install the barrel on the beam pipe.
- Install (*or machined*) the support rings on beam pipe in advance, then directly install the ladders (preferred for inner most layer).

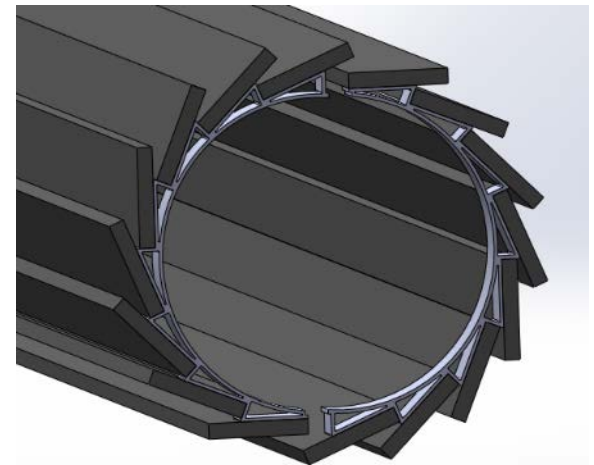

VTX installation on the beam pipe

The support ring can be either glued/bolted to or pre machined on the beam pipe related parts. (for the inner most layer bolted connection is too difficult)

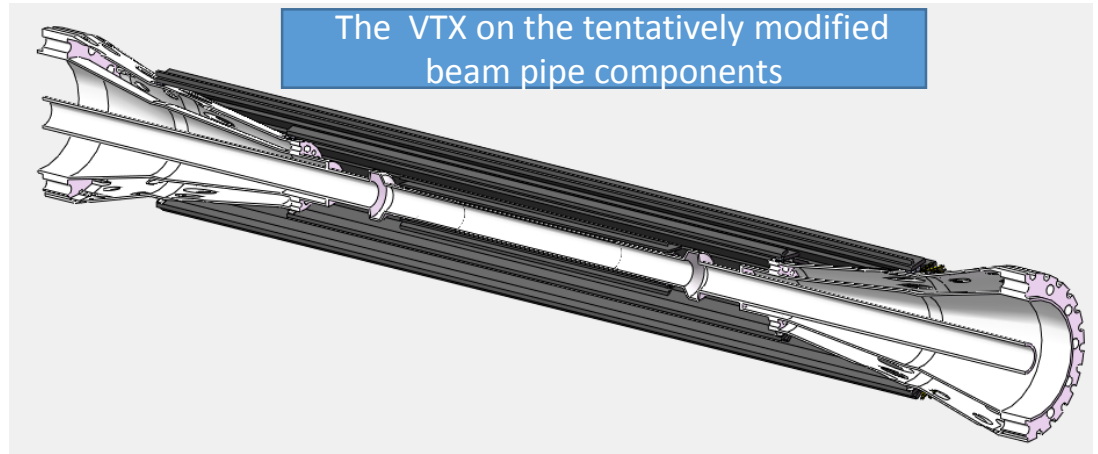

The option that pre-assembled halves of barrels mounted onto the beam pipe (dedicated tooling required)

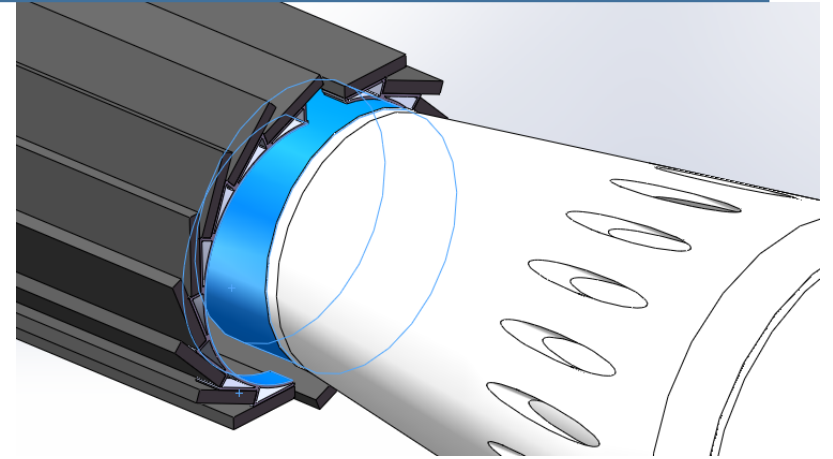
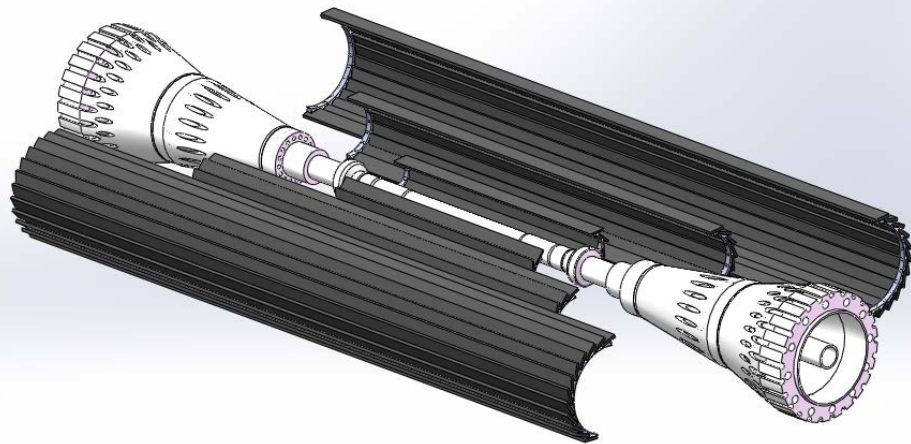

*More consideration - different constraint on two ends?

Air channels and cables routing

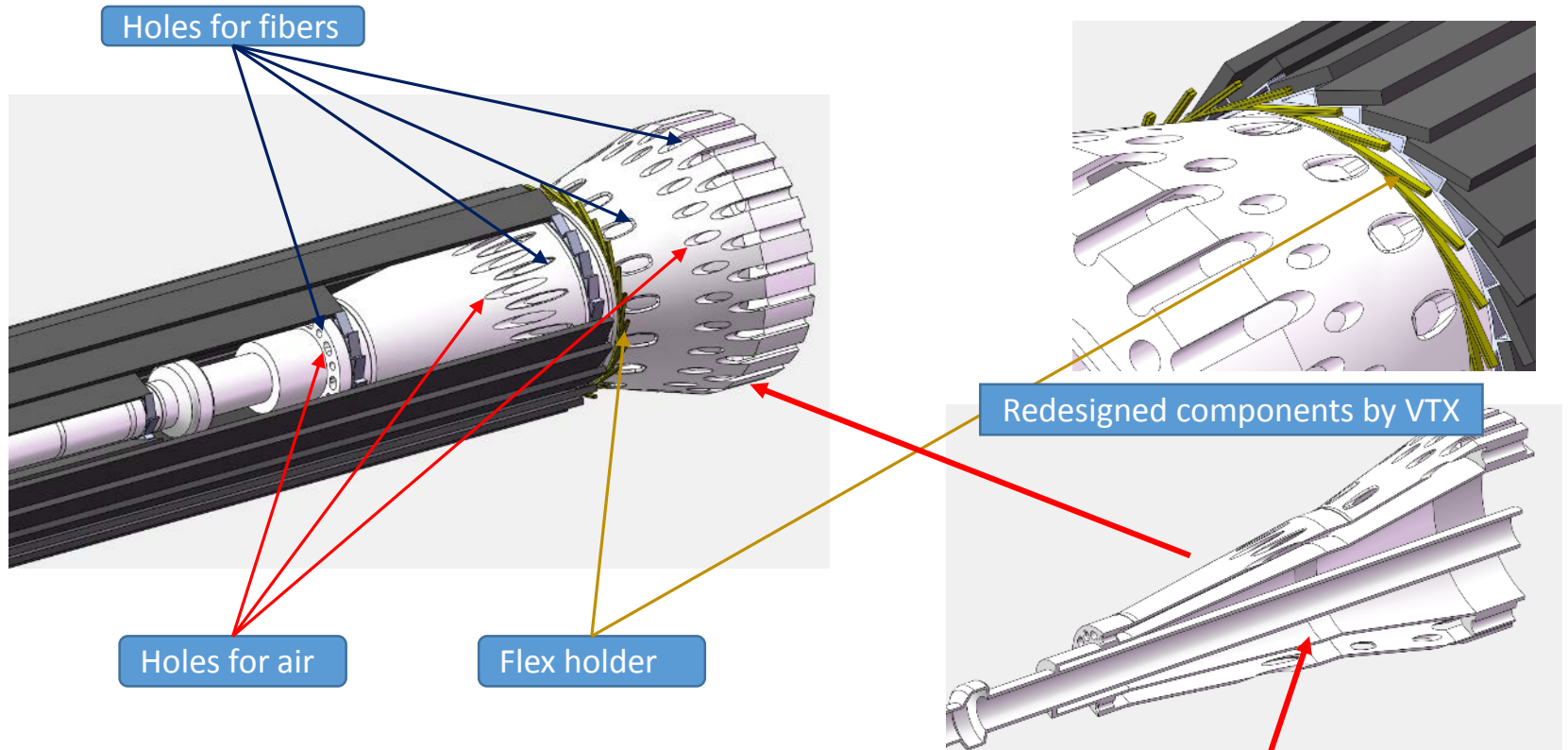

According to the current plan, assuming the flex will be switched to fiber where beyond and near the end of the ladder.

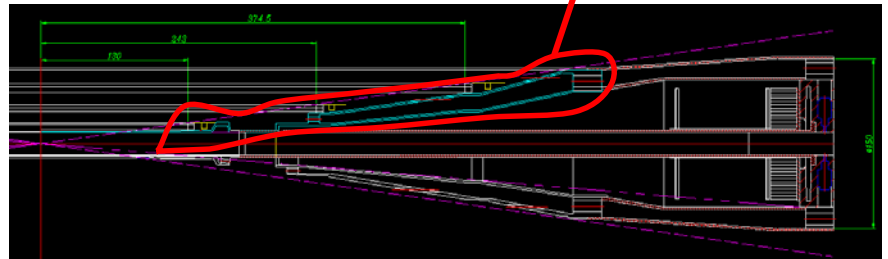

Cooling simulation of the VTX - long barrel

Power dissipation: 50 mW/cm²

Total heat generation of the VTX: 421 W

Inlet air temperature 5 °C

In current simulation beam pipe temperature not considered



Layer of barrel	Chip coverage (mm)	Number of ladders	Heat generation-of barrels(W)	Simulation results the Max temp (Celsius)
inner	14.8x260	8	27	82
middle	14.8x494	16	117	34.5
outer	14.8 x749	25	277	37.2

- Based on a rough calculation, given 15 degrees Celsius rise, the estimated air flow rate is 1.49 m³/min. *In the sectional area of the barrels the average speed about 2.3 m/s.*
- In the simulation, transfer the flow rate to 12 inlet pipes with ID-8mm, the air speed is 41 m/s (it can be reduced by increasing the inlets)
- Cooling setup with a lower flow rate was also tried but resulted with much higher temperature then this case.

Cooling simulation of the VTX - long barrel -updated

Power dissipation: 50 /40/30 mW/cm²

Total heat generation of the VTX: 421 /337/253 W

Inlet air temperature 5 °C

Beam pipe temperature not considered



Layer of barrel	Chip coverage (mm)	Number of ladders	Heat generation- of barrels(W)	Simulation results the Max temp (Celsius)		
inner	14.8x260	8	27	82	66.6	51.4
middle	14.8x494	16	117	34.5	27.8	22.1
outer	14.8 x749	25	277	37.2	30.2	24

Cooling simulation of the VTX - long barrel -updated

Power dissipation: 50 /40/30 mW/cm²

Total heat generation of the VTX: 421 /337/253 W

Inlet air temperature 5 °C

Beam pipe temperature 26 °C



Layer of barrel	Chip coverage (mm)	Number of ladders	Heat generation- of barrels(W)	Simulation results the Max temp (Celsius)		
inner	14.8x260	8	27	60.6	49.1	42.2
middle	14.8x494	16	117			
outer	14.8 x749	25	277			

Considerations on cooling

- Change the ladder support material – high conductivity (X, more material increase)
- Adding a thin layer of material that has a high thermal conductivity (no much contribution - previous study)
- Low temperature environment? (thermal isolation required to avoid condensation within tracker / or flushed N2 within tracker, also high flow, too much material / cost)
- *Adjust the gap to beam pipe*
- *Higher air flow rate*
- ***A potential solution for the inner most layer detector is adding thermal conductive glue between the detector and beam pipe.***

The cooling scheme of gluing detector to beam pipe

- ✓ *Add thermal conductive glue between the inner most layer detector and beam pipe.*
- ✓ *Material is being investigated*
- ✓ *New analysis to evaluate the contribution of cooling by heat conductivity to the beam pipe is being prepared.*

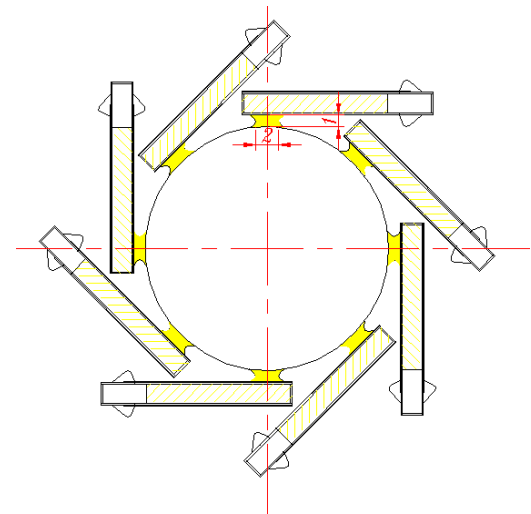

backup

Analysis of Cooling Effect of High Thermal Conductivity Material

A trial analysis to evaluate the influence of employing material with a high thermal conductivity (Mhc) on ladder cooling.

A given ladder with a sensor (20 x 258 x 2 mm) on one side, dissipation 150 mW/cm².

- ladder support (Aluminum)
- support block (Aluminum alloy).
- sensor (silicon with a thickness of 0.05 mm)
- FLEX

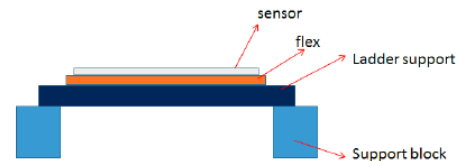

*a thickness of 0.124mm,
material: PCB (0.3w/m.K) VS Mhc (1500w/m.K)*

FPC materials	T: °C (V=3m/s)	T: °C (V=3m/s*)	T: °C (V=1m/s)	T: °C (V=1m/s*)
PCB	36.3	<u>32.6</u>	46.9	<u>36.7</u>
Mhc	35.5	<u>30.7</u>	45.7	<u>33.6</u>
T difference:	0.8	<u>1.9</u>	1.2	<u>3.1</u>

The results show that such a thin material with high conductivity contributes little to enhance cooling effect.