

IDRC Review on HCAL: Feedback and Work Plan

WWW.IHEP.CAS.CN

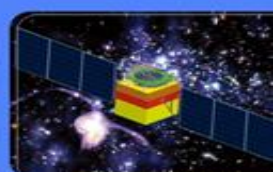

qians@ihep.ac.cn

2024-10-28

CALORIMETRY

Findings

The electromagnetic calorimeter (ECal) and hadronic calorimeter (HCal) teams are strong and productive. They are generally making good progress on their technologies.

Three technologies have also been investigated and studied for the HCal:

- semi-digital RPC-based calorimeter;
- plastic scintillator calorimeter;
- and glass scintillator calorimeter.

The glass scintillator has been chosen for the hadron calorimeter baseline based on its significantly better energy resolution below 80 GeV, where the hadrons populate from Higgstrahlung at 240 GeV. R&D has demonstrated excellent performance on a limited scale. The other two approaches have been developed and are potential alternatives.

The simulated jet reconstruction using PFA based on these two ECal and HCal baseline choices shows excellent performance.

The HCal effort also confronts large challenges. While significant progress has been made, including beam testing of a prototype detector, much remains to achieve the maturity that is required. The glass scintillator concept is innovative, with limited experience in the particle physics detector community to draw from. Some of the critical aspects that need urgent attention include:

- Mature development of the glass scintillator technology, demonstrating mass production and cost containment with uniform properties such as high density, high light yield, large attenuation length, and short decay time;
- Optimization of ECal design granularity based on simulated physics performance;
- Optimization of other aspects including GS-SiPM coupling, mechanics, cooling, and electronics;
- Preparation and beam testing of full-size HCal prototype.
- The ECal-HCal transition region must be evaluated with attention to physics performance.

Given the short time scale, management oversight and support is essential to ensure successful achievement of these goals.

Comments from IDRC

- Mature development of the glass scintillator technology, demonstrating mass production and cost containment with uniform properties such as high density, high light yield, large attenuation length, and short decay time;
- ● Optimization of ECal HCal design granularity based on simulated physics performance;
----(Physics + Design)
- ● Optimization of other aspects including GS-SiPM coupling, mechanics, cooling, and electronics;
----GS-SiPM coupling (GS+SiPM);
----mechanics +cooling (Mechanics),
----electronics (Electronics)
- ● Preparation and beam testing of full-size HCal prototype.
----(Detector, also need more money for the full-size prototype)
- ● The ECal-HCal transition region must be evaluated with attention to physics performance.
----(Physics + Design)

The Manpower of the subsystem of GSHCAL

Physics: Manqi Ruan(IHEP), Haijun Yang (SJTU) ,

Software: Sengsen Sun(IHEP);

Design: Fangyi Guo(IHEP), Hengne Li(SCNU), Qingming Zhang(XJTU), Weizheng Song(IHEP), Peng Hu(261)
Dejing Du(IHEP), Hongbing Diao(SUTC), Jiyuan Chen(SJTU),

--to design the GS-HCAL detector based on the CEPCSW;

Glass Scintillator: Sen Qian(IHEP), Jing Ren(HEU), the GS collaboration Group;

--R&D of the GS for CEPC-HCAL, a special group independent of CEPC;

SiPM: Yuguang Xie(IHEP), Jifeng Han(SCU), Guang Luo(SYSU),

--to do the research of SiPM for CEPC-HCAL, the electronics of SiPM for the GS performance test;

Electronics: Jingfan Chang(IHEP),

--to design the ASIC and FEE for CEPC-HCAL; the power supply, the cables and so on;

DAQ: Chen Boping(IHEP),

Mechanics: Yatian Pei(IHEP), Junsong Zhang(IHEP), Shang Bofeng(ZZU)

--to design the Mechanics of the GS-CEPC-HCAL; also the cell, the module, the cooling system;

Detector: Boxiang Yu(IHEP), Yunlong Zhang (USTC)

--to study the module of the GS-HCAL with GS and SiPM, the cosmic ray test, the beam test;

the Conceptual Detector Design of GS-HCAL

➤ Endcap-module

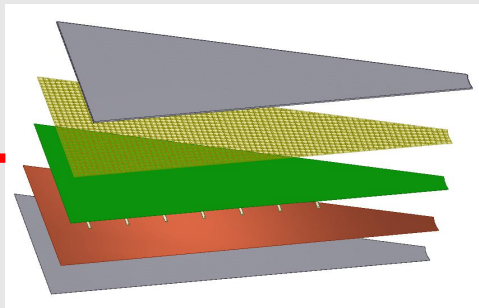

X 1400

➤ GS-Cell
5.20M Pics

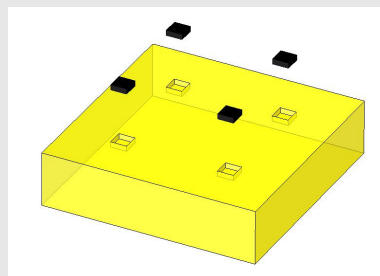

X 4000

➤ Barrel-module

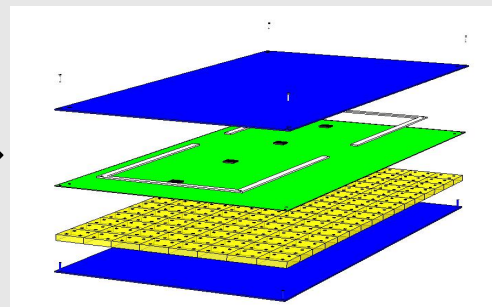

X 48

X 48

➤ Endcap-Prototype

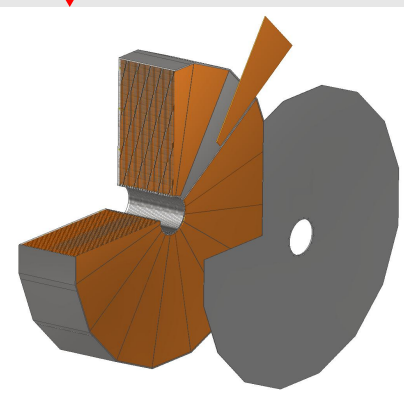

➤ Endcap-Detector

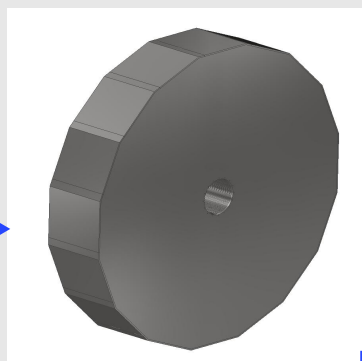

X 16

➤ CEPC-GS-HCAL

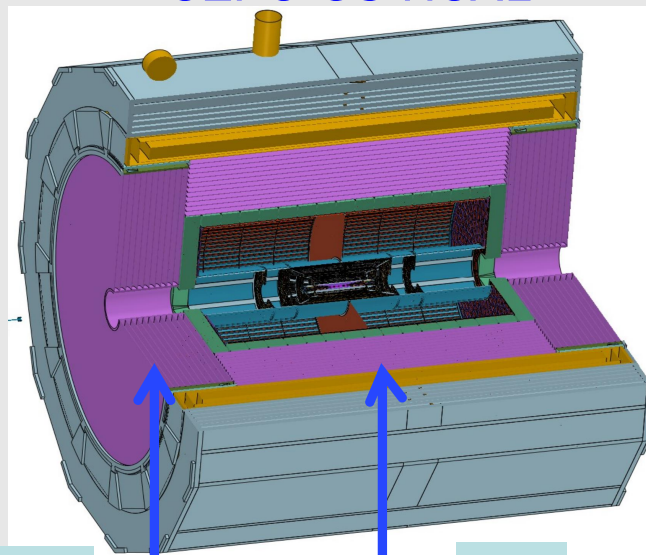

X 2

X 1

➤ Barrel-Prototype

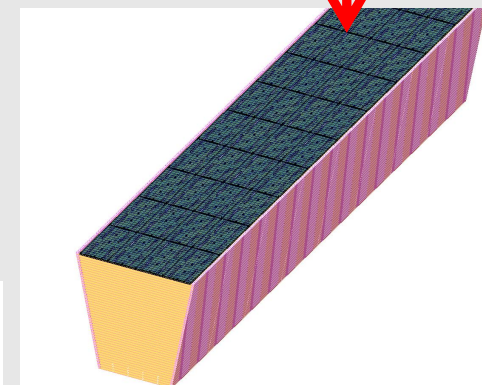

➤ Barrel-Detector

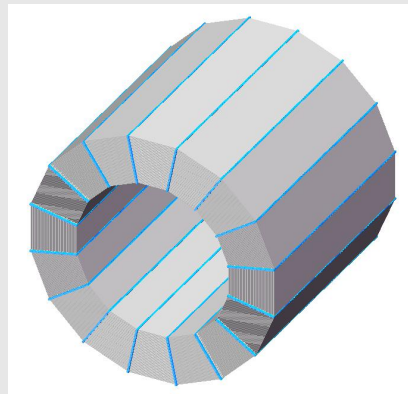

X 16

Recommendations

1. The new technologies chosen for the baseline ECal and HCal technologies are innovative and challenging. Steady progress must be maintained in prototyping and simulation. The concepts are feasible and attractive, but need steady and significant preparation to prove readiness, along with final specifications.
2. One aspect that must be monitored and perfected is the reproducibility of glass scintillators.
3. Design choices should be thoroughly justified by physics goals achieved with simulation of a full detector model. Alternative parameter choices should be considered and evaluated for physics outcomes. For example, ECal crystals of 1 cm (transverse) x 2 cm (depth) would reduce channel count and cost. Does it impact physics performance?
4. Some specific performance issues that would be interesting to more fully understand. These include higher energy pi zero reconstruction, which may benefit, for example, from a staggered bar arrangement or finer granularity in the first few layers. Also electron ECal resolution when the bending of electrons match the 12 degree incline angle. Does this impact electron measurements?

the V1.0 of the Chapter of HCAL

Chapter 8 Hadron calorimeter--V1.0

- 8.1 Introduction
- 8.2 Requirements
- 8.3 Survey of HCAL technical options
 - 8.3.1 Semi-Digital HCAL based on RPC (SDHCAL)
 - 8.3.2 Analogue HCAL based on plastic scintillator(PS-HCAL)
 - 8.3.3 Analogue HCAL based on glass scintillator (GS-HCAL)
 - 8.3.4 HCAL option selection for the reference detector
- 8.4 Critical issues and technical challenges
- 8.5 R&D efforts and results
- 8.6 Designs including electronics, mechanics and cooling
- 8.7 Performance from simulation and beam test
- 8.8 Summary

- 8.1 Physics Requirements of HCAL
- 8.2 Design of the GS-HCAL
 - 8.2.1 the introduction of CEPC-SW-HCAL
 - 8.2.2 the beam background simulation
 - 8.2.3 the standalone module simulation
 - 8.2.4 the PFA performance simulation
- 8.3 The Glass Scintillator
 - 8.3.1 the Scintillator materials
 - 8.3.2 the performance of 5cm cube sample of GS1
 - 8.3.3 the performance of 5cm cube sample of GS1+
 - 8.3.4 the performance of 4cmX4cmX1cm sample of GS1
 - 8.3.5 the MIP response of the GS1
- 8.4 The SiPM
 - 8.4.1 the introduction of SiPM
 - 8.4.2 the electronics for the SiPM test
 - 8.4.3 the performance study of the SiPMs
 - 8.4.4 the performance of the GS-HCAL-Cell
- 8.5 The Electronics & DAQ
 - 8.5.1 the Electronics for SiPM
 - 8.5.2 Readout Electronics
 - 8.5.3 the DAQ for GS-HCAL
- 8.6 The Mechanics
 - 8.6.1 the Barrel part
 - 8.6.2 the endcap part
 - 8.6.3 the cooling part
- 8.7 The Detector Layout
 - 8.7.1 the GS-HCAL-Module
 - 8.7.2 the GS-HCAL-Prototype
 - 8.7.3 the beam test
- 8.8 The Backup Design
 - 8.8.1 Semi-Digital HCAL based on RPC (SDHCAL)
 - 8.8.2 Analogue HCAL based on plastic scintillator (PS-HCAL)