



中子和基础物理

童欣

中国散裂中子源

中国科学院高能物理研究所



Contents

- ❑ Introduction of Neutron Scattering and Neutron Sources
- ❑ Neutrons for fundamental Neutron Physics
- ❑ Concluding remarks

I've borrowed slides / pictures from:....

- Geoff Greene
- Mike Snow
- Nadia Fomin
- Takeyaso Ito
- Florian Piegsa
- Wiki / Google

Discovery of Neutrons

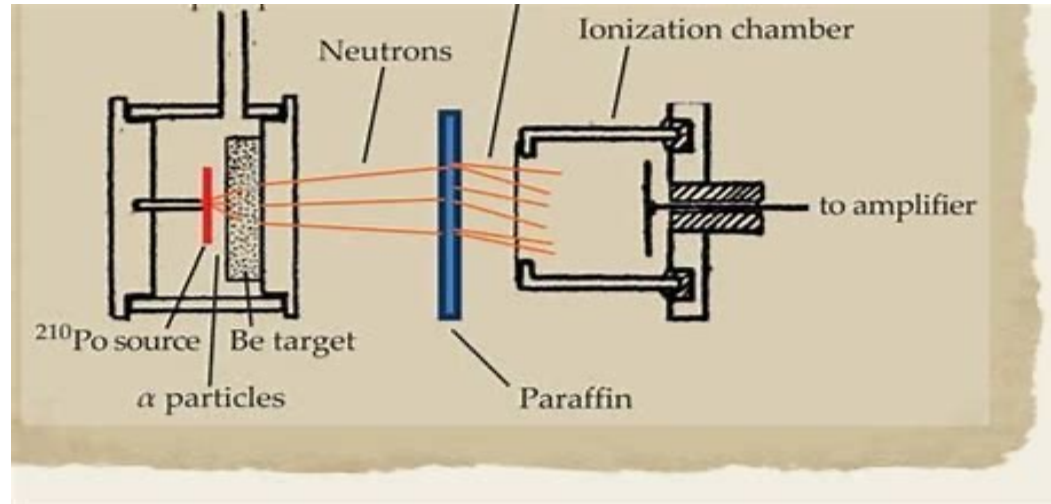
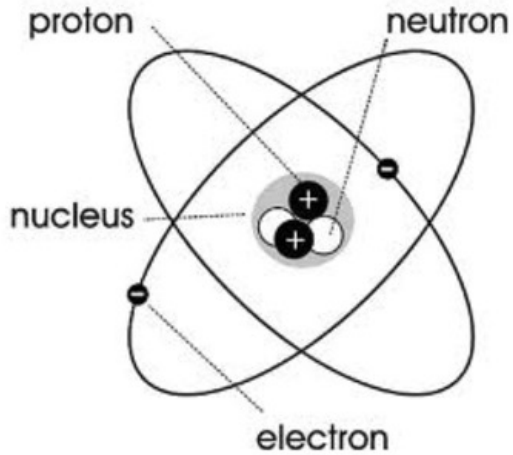

“It is, of course, possible to suppose that the neutron may be an elementary particle...
This view has little to recommend it at present.”

James Chadwick
1932年发现中子
1935年物理学诺奖

J. Chadwick, Proc. Roy. Soc., A 136 692 (1932)

Properties of free neutrons

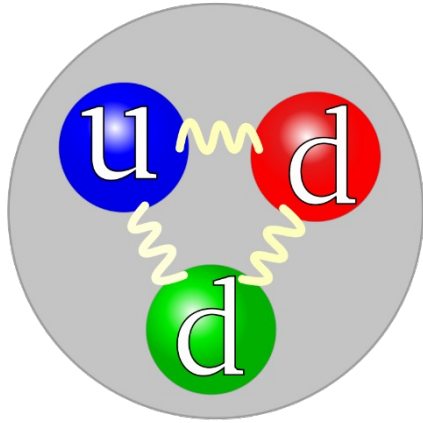

- Baryons
- Electrical Neutral ($<10^{-22}e$)
- Spin = $\frac{1}{2}$
- Magnetic moment: $-1.913 \mu_N$
- Mass = 939.566 MeV
- Lifetime $\sim 880s$
- Electrical dipole moment: $< 1.3 \times 10^{-26} e \cdot cm$

- Difficult to handle, can't accelerate/guide/focus
- Destruction to detect
- Low flux
- Respond to all four forces, and possibly "fifth" force
- Simpler compare to nucleus
- Polarization is a unique feature



Free Neutrons are hard to get

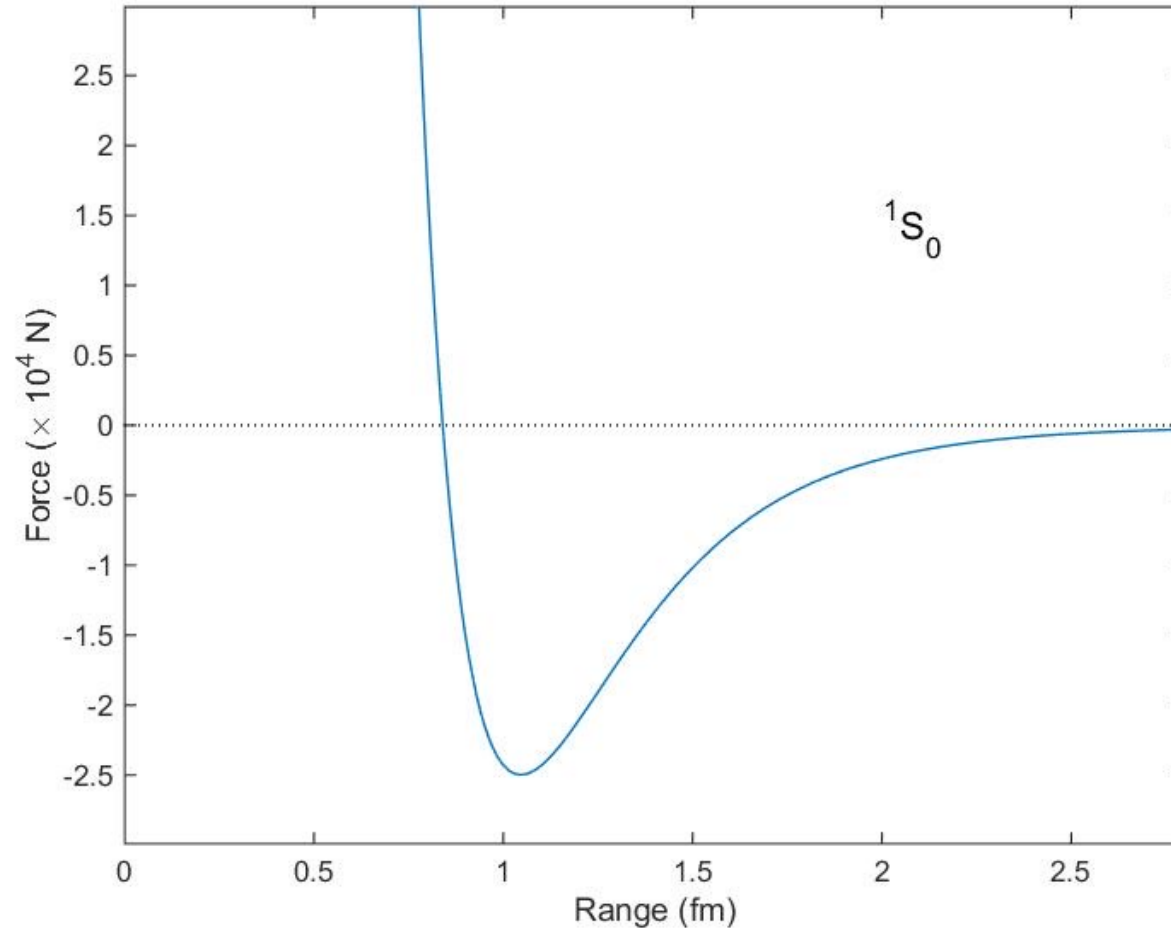

- Neutrons are bound in nuclei, need several MeV for liberation
- Neutron decays \rightarrow can't accumulate
- We want free neutrons, very expensive to get



First Reactors

1940s CP1

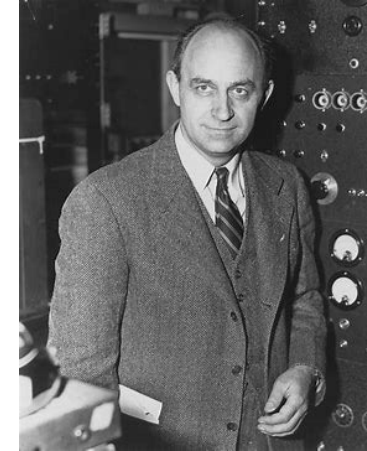
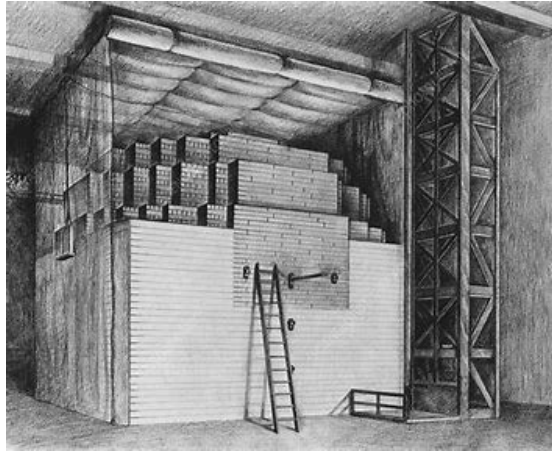

1950s 美国橡树岭国家实验室

- First continuous reactor
- First neutron scattering
- First neutron EDM
- First neutron lifetime



Neutron Scattering

Neutron Scattering for material structure and dynamics

- Wavelength $\sim \text{\AA}$
- Energy $\sim \text{meV}$

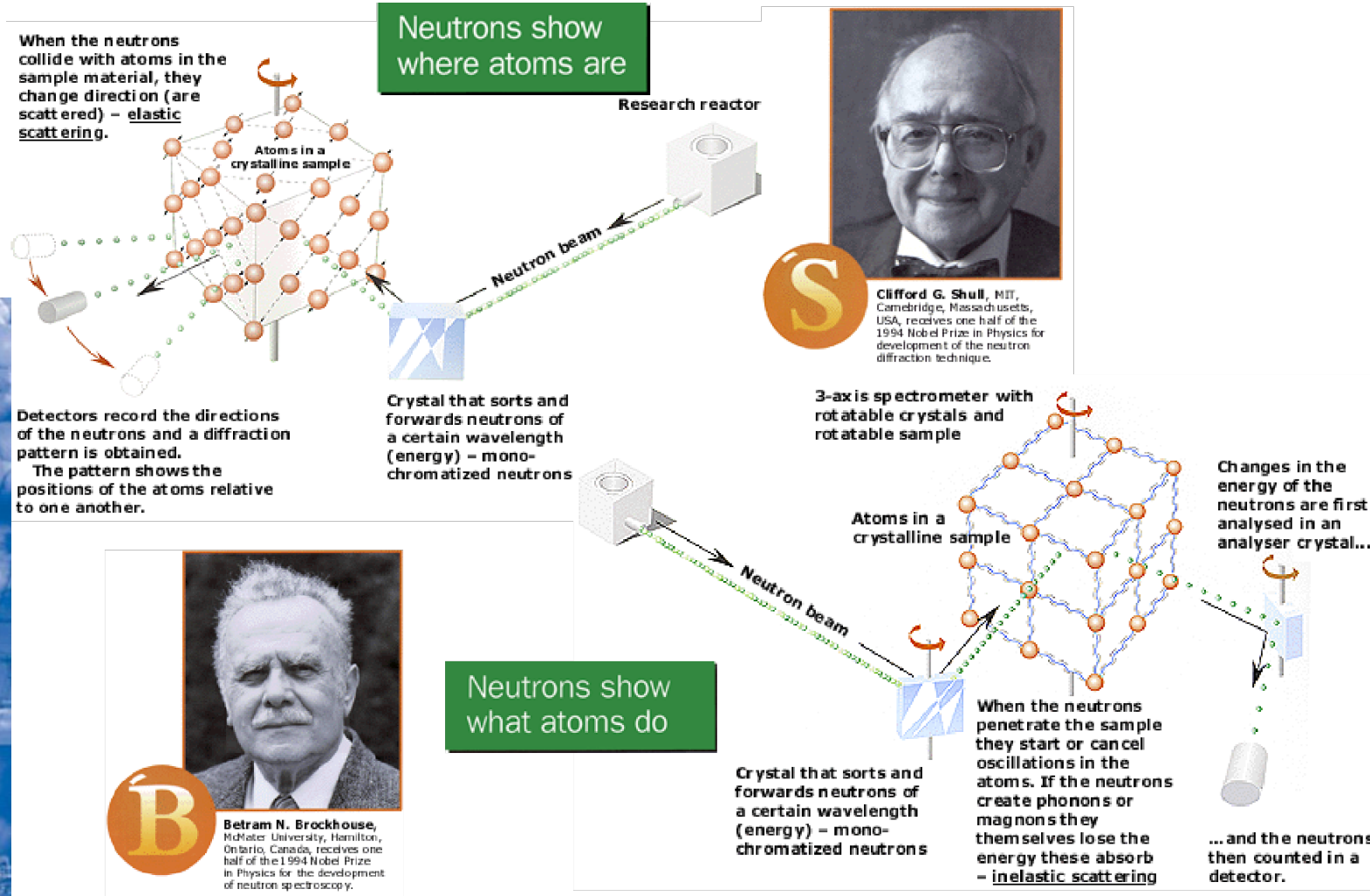
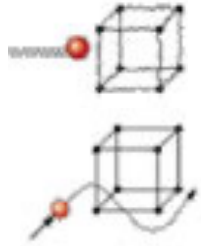

Spallation Neutron Sources

Large-scale National science facility

CSNS, Dongguan China



- ❖ Commissioned 2018, ¥ 2.3 billion
- ❖ Phase-II upgrade: ¥ 3 billion

SNS, Oak Ridge US



- ❖ Commissioned 2006, \$1.4 billion
- ❖ Phase-II upgrade: \$2 billion

- ❑ Large-scale open user facility for neutron scattering experiment
- ❑ Complimentary to X-Ray and electron scattering



China Spallation Neutron Source

散裂中子源为材料科学技术、物理、化学化工、资源环境、新能源、纳米、生命科学、国家安全等前沿研究和国家重大需求，特别是高水平科技自立自强提供先进的中子散射**研究平台**。

- 主管部门：中国科学院
- 共建部门：广东省人民政府
- 法人单位：高能物理研究所
- 共建单位：物理研究所
- 批复概算：18.6632亿元
- 建设选址：广东省东莞市大朗镇

- 开工时间：2011年9月
- 建设周期：6.5年，2018年3月完工
- 开放运行：2018年8月
- 二期开工：2024年1月
- 二期批复：~29亿元



Schematics of CSNS

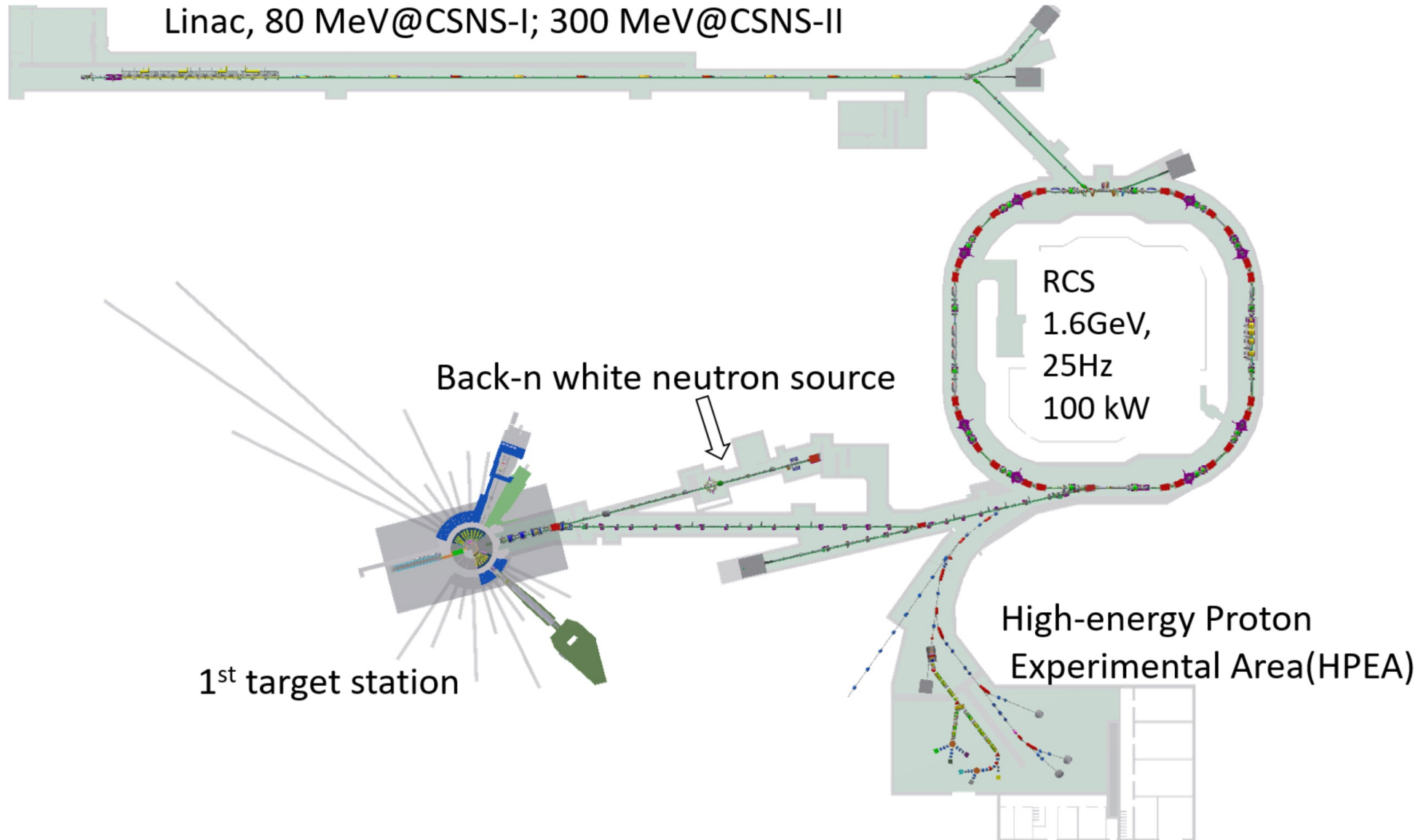



- Low-cost D&P steel with high yield strength (~ 2 GPa), excellent toughness ($102 \text{ MPa} \cdot \text{M}^{1/2}$), and good ductility (19% uniform elongation) from Hongkong University.
- Important microscopic parameter information such as phase volume fraction and dislocation density was obtained through neutron diffraction @GPPD

Science

REPORTS

Cite as: L. Liu *et al.*, *Science* 10.1126/science.aba9413 (2020).

Making ultrastrong steel tough by grain-boundary delamination

L. Liu^{1*}, Qin Yu^{2*}, Z. Wang¹, Jon Ell^{2,3}, M. X. Huang^{1†}, Robert O. Ritchie^{2,3†}

¹Department of Mechanical Engineering, The University of Hong Kong, Pokfulam Road, Hong Kong, China. ²Materials Sciences Division, Lawrence Berkeley National Laboratory, Berkeley, CA 94720, USA. ³Department of Materials Science and Engineering, University of California, Berkeley, CA 94720, USA.

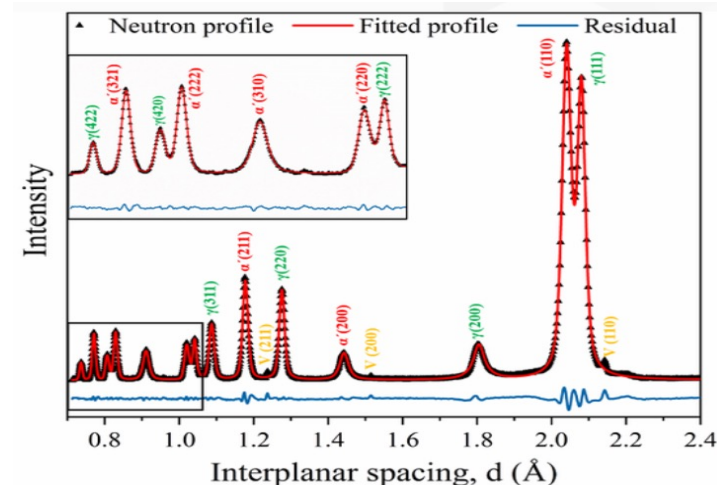
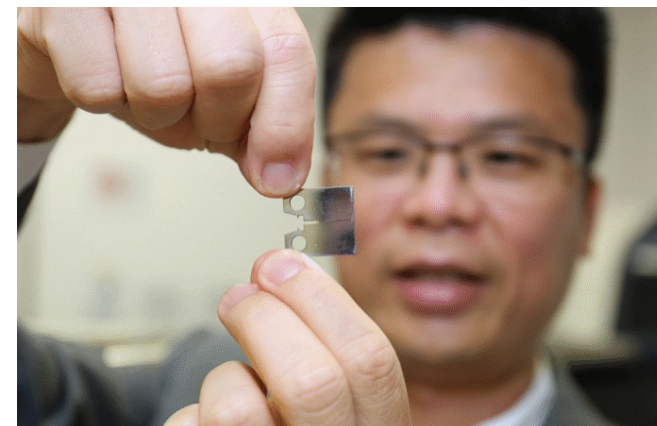

Liu *et al.* *Science*
2020, 368, 1347-1352



Catalyst & MOF

- Neutron Diffraction @ GPPD determines the fine structure of carbon dioxide in iron-containing mordenite, which has record high of carbon dioxide uptakes.

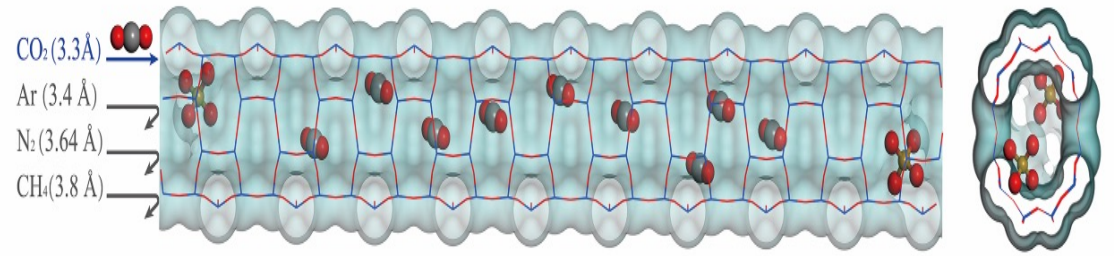

RESEARCH

GAS SEPARATION

Self-assembled iron-containing mordenite monolith for carbon dioxide sieving

Yu Zhou^{1†}, Jianlin Zhang^{1†}, Lei Wang^{2†}, Xili Cui^{3,4†}, Xiaoling Liu^{1†}, Sie Shing Wong^{5,6}, Hua An^{5,6}, Ning Yan^{5*}, Jingyan Xie¹, Cong Yu³, Peixin Zhang³, Yonghua Du^{7,8}, Shibo Xi⁷, Lirong Zheng⁹, Xingzhong Cao¹⁰, Yajing Wu², Yingxia Wang¹¹, Chongqing Wang¹, Haimeng Wen¹, Lei Chen¹, Huabin Xing^{3,4*}, Jun Wang^{1*}

Zhou *et.al.* Science, 2021,373,315-320

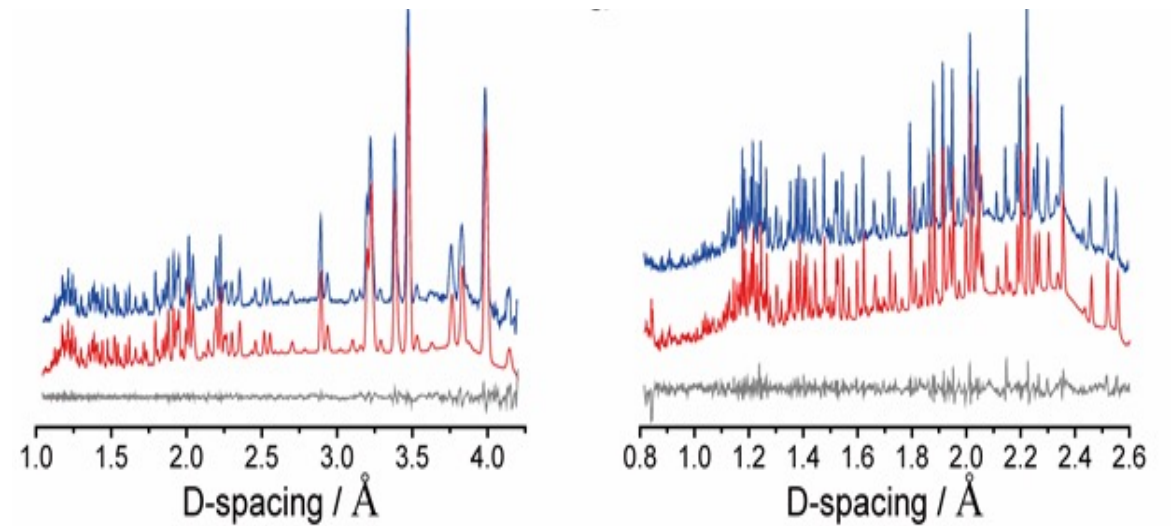

富勒烯

- Long-range ordered porous carbon crystal (LOPC) by USTC. It is a new class of carbon-based crystal structures between graphite and C60 molecular.

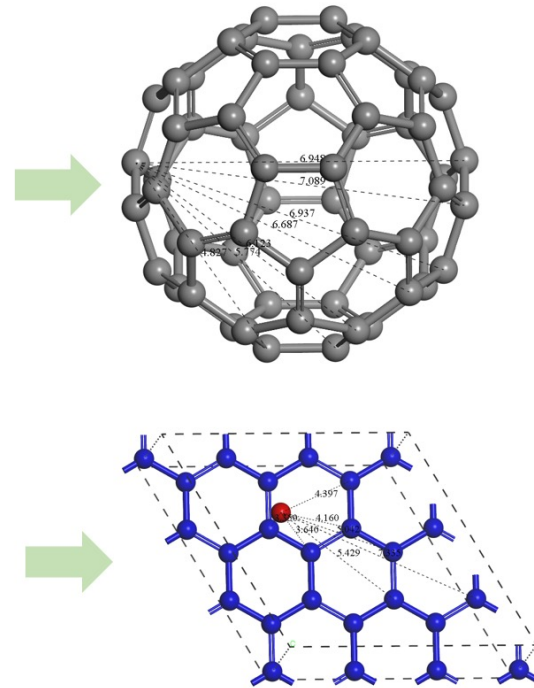
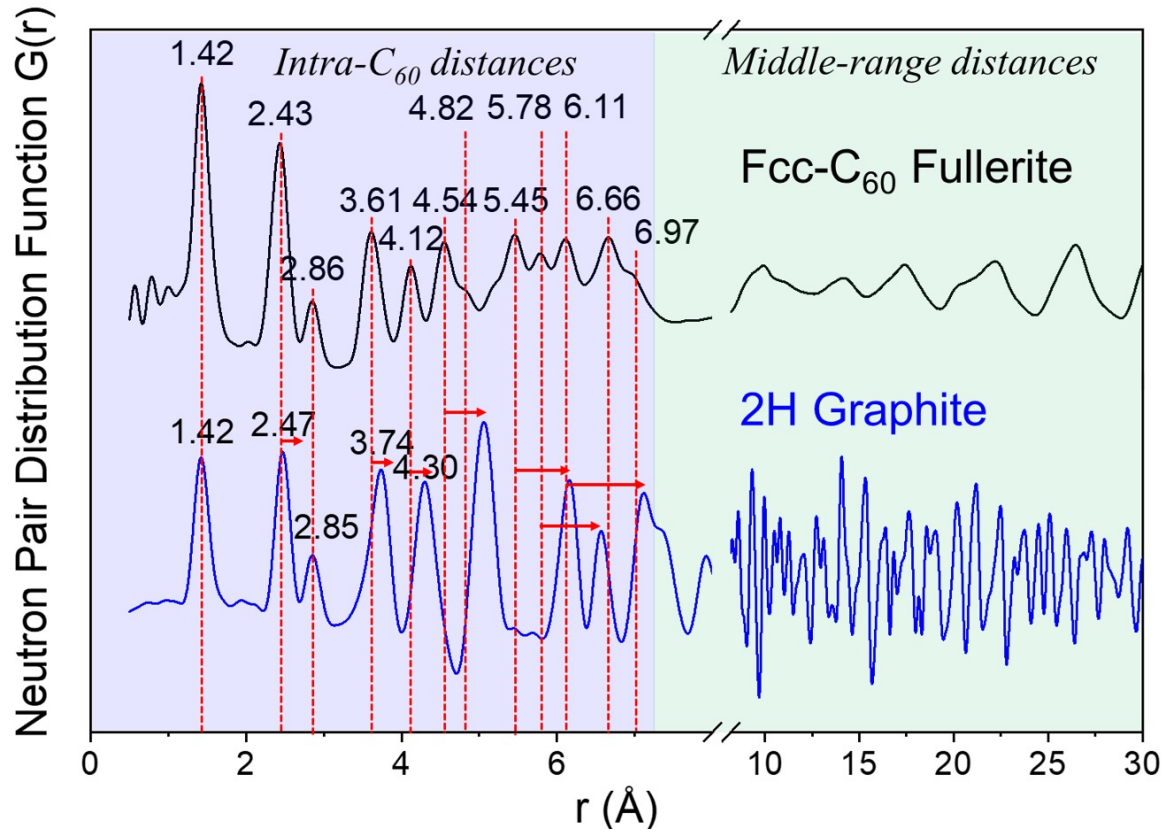

@MPI accurately reveal the short and medium range ordered structures of Fullerene and 2H graphite.

Battery

- The lanthanide all solid-state electrolyte material with good interface compatibility achieves rapid conduction of lithium ions and stable cycling of solid-state lithium batteries. USTC Hong-Bin Yao' s group.
- Combined refinement of TOF neutron data (@MPI) and synchrotron X-ray was conducted to acquire a more convincing crystal structure.

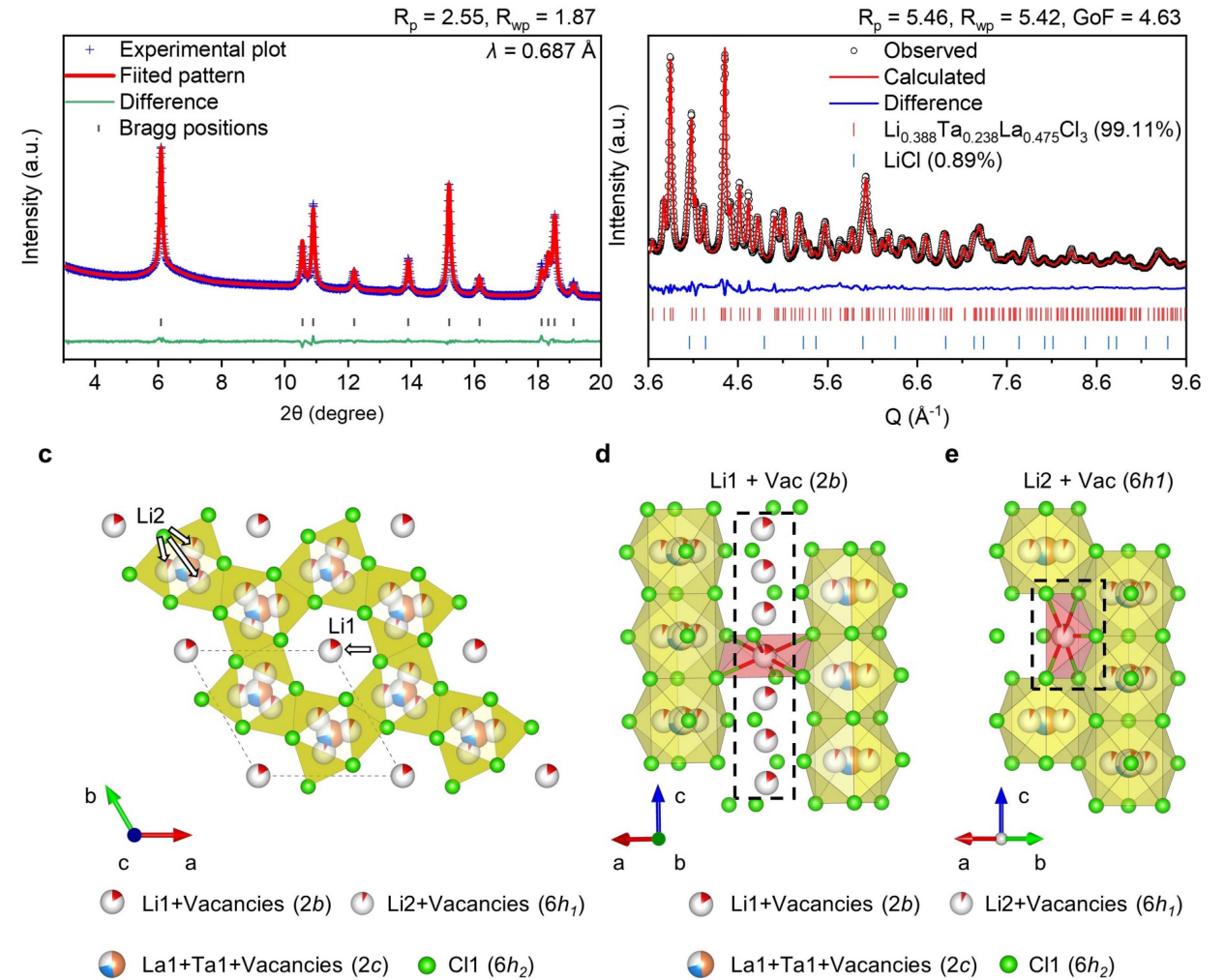

Strategical goals of neutron sources

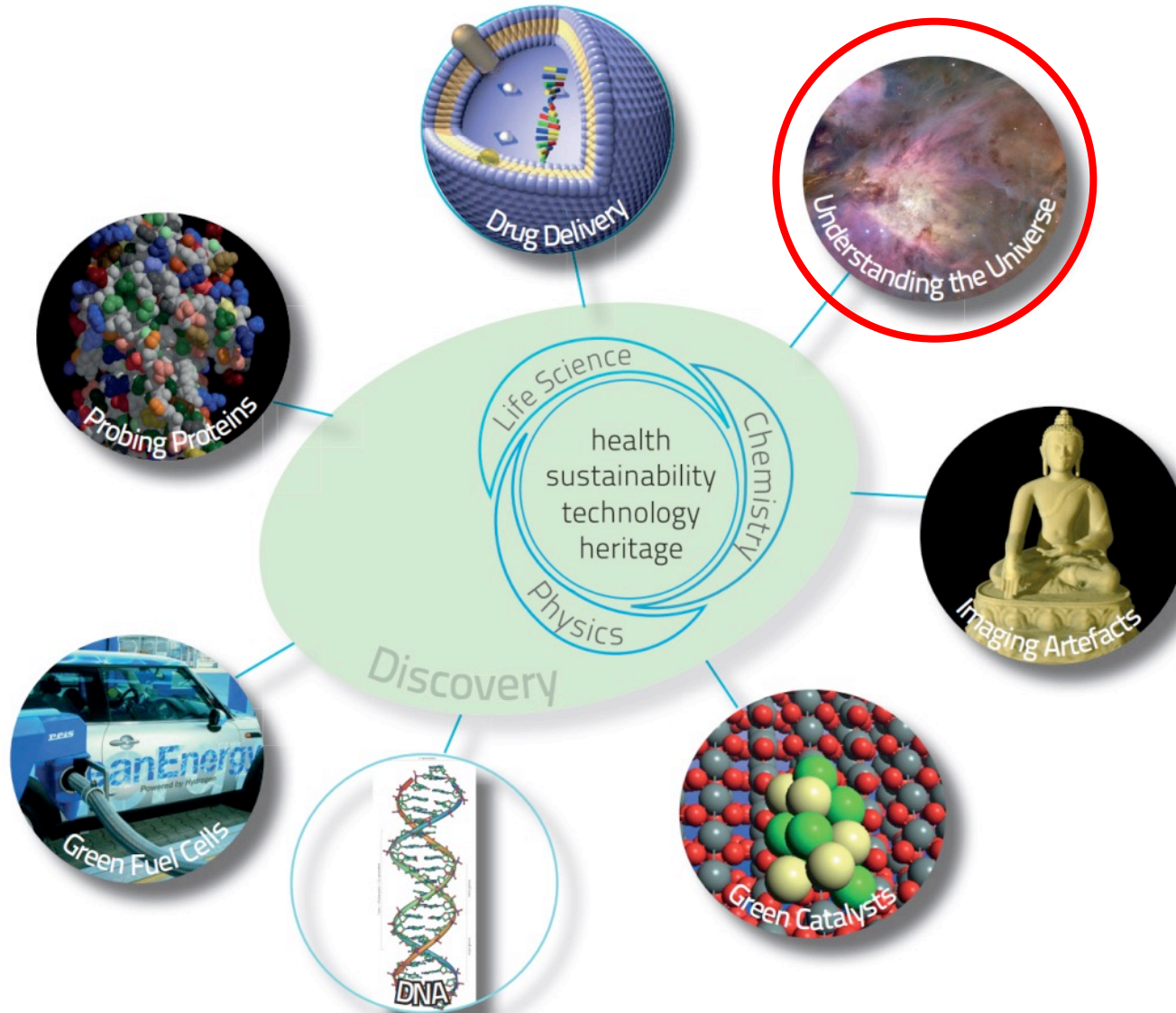



Neutron Physics can address “big” questions

- Why does the universe contain only matter but not Anti-matter? **Baryon Asymmetry**
- How were the elements made at the birth of the universe? **Nucleosynthesis**
- Why does the universe shows a preference between left and right handedness? **Parity Violation**
- Beyond Standard Model? **Dark Matter, New Physics**
- Direct macroscopic quantum effect **Bell' s inequality, quantum phases**



Several high-impact experiments



Baryogenesis and CP Violation

A. Sakharov's solution to Baryon Asymmetry Problem

- Baryon number violating process
- A period of Non- thermal equilibrium
- The presence of C and **CP violation**

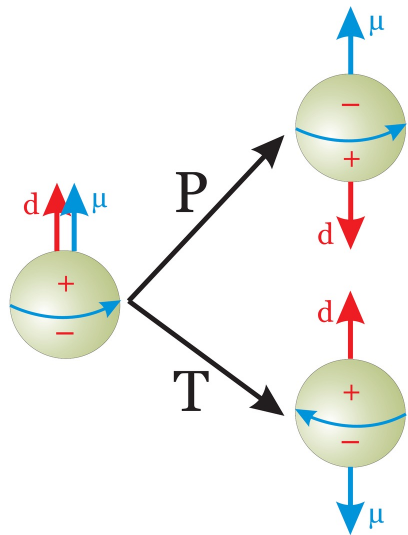

Non-zero neutron electrical dipole moment --> P and CP violation

Neutron EDM experiment (a negative experiment)

- CP Violation, Baryogenesis
- New Physics

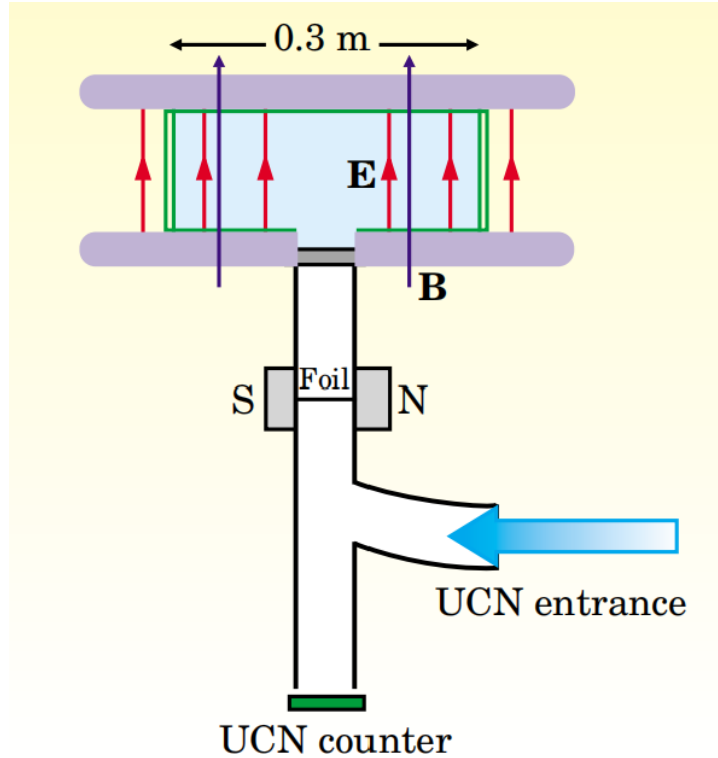

E. Purcell
N. Ramsey

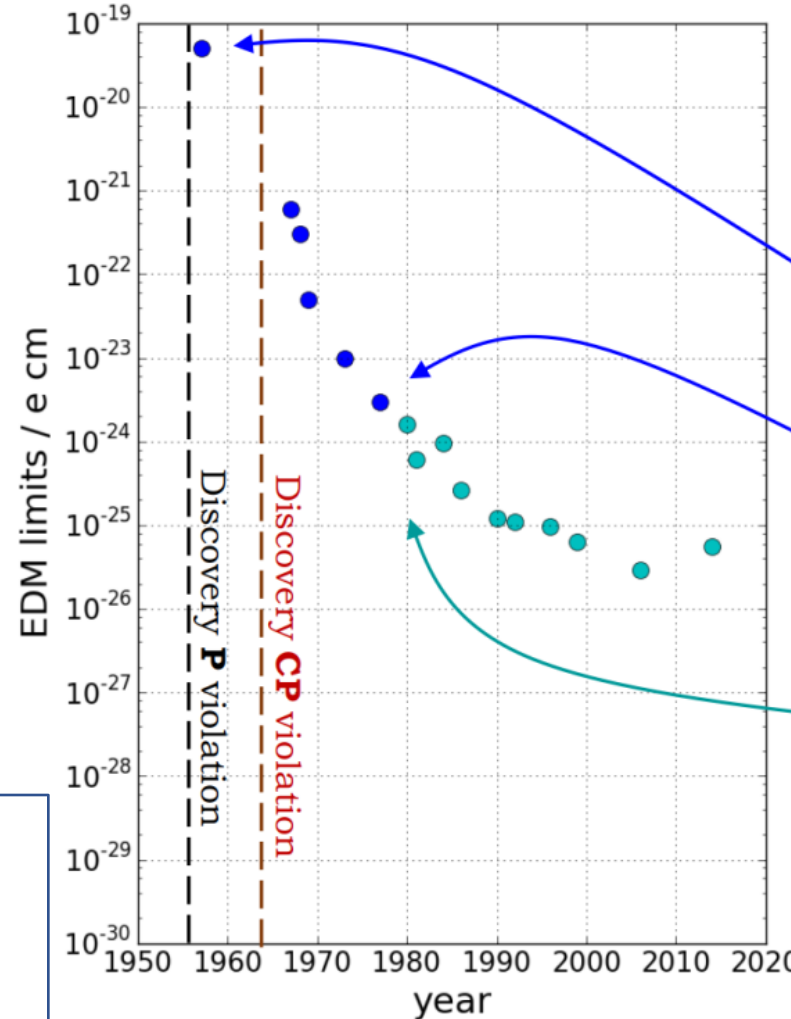

First experiment by Smith, Purcell and Ramsey with a **beam of thermal neutrons**, interrogation time $T \approx 1$ ms

Best « beam » experiment in Grenoble with **slower neutrons**, interrogation time $T \approx 20$ ms

« Modern » experiments with **ultracold neutrons** started. interrogation time $T \approx 100$ s

Reversing electrical field provides a different neutron Larmor precession frequency



Premordial nucleosynthesis

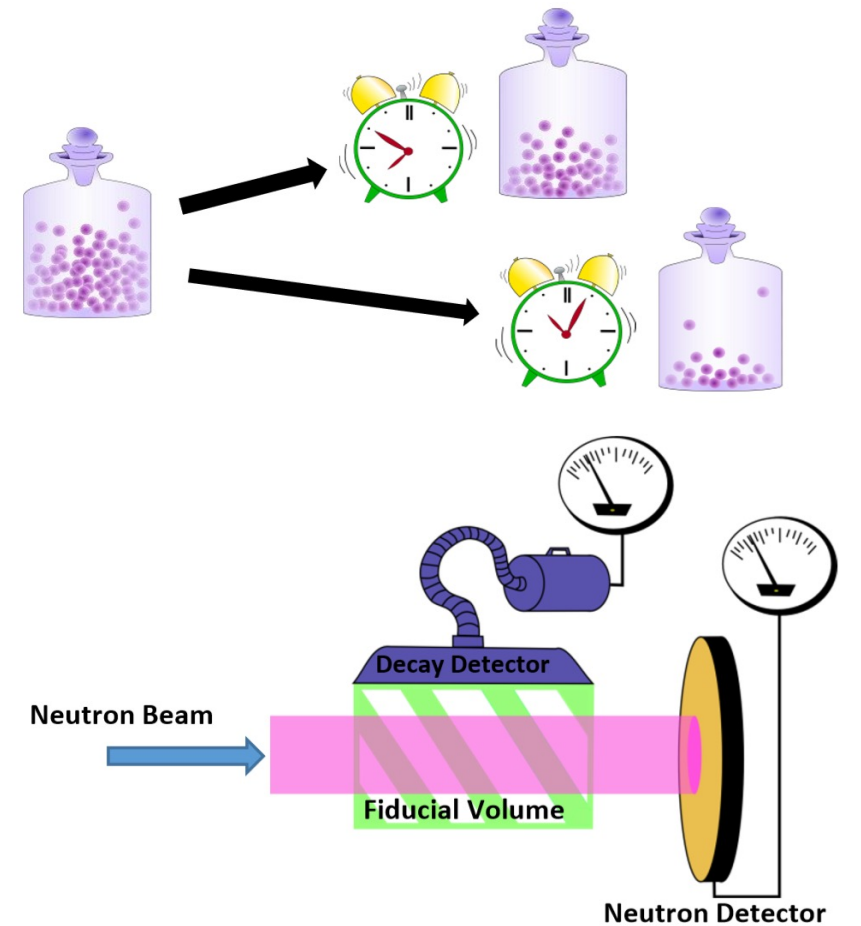
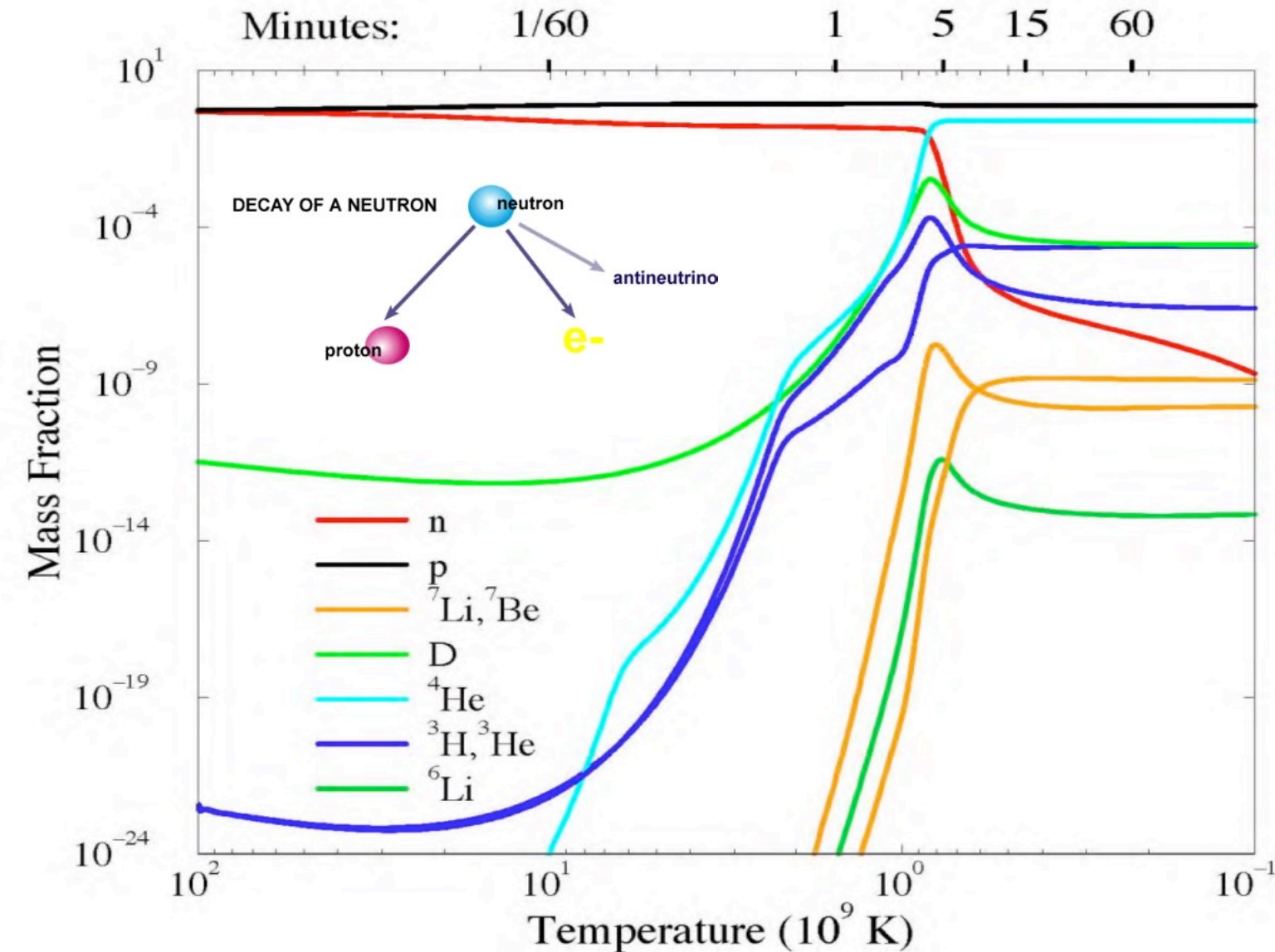



Neutron lifetime puzzle

UNRESOLVED DIFFERENCES

Mysteriously, neutrons in a beam live several seconds longer on average than do those trapped in a vacuum bottle.

Science **360**, 6389 (2018)
Nature **598**, 549 (2021)
Phys. Rev. Lett. **127**, 162501 (2021)

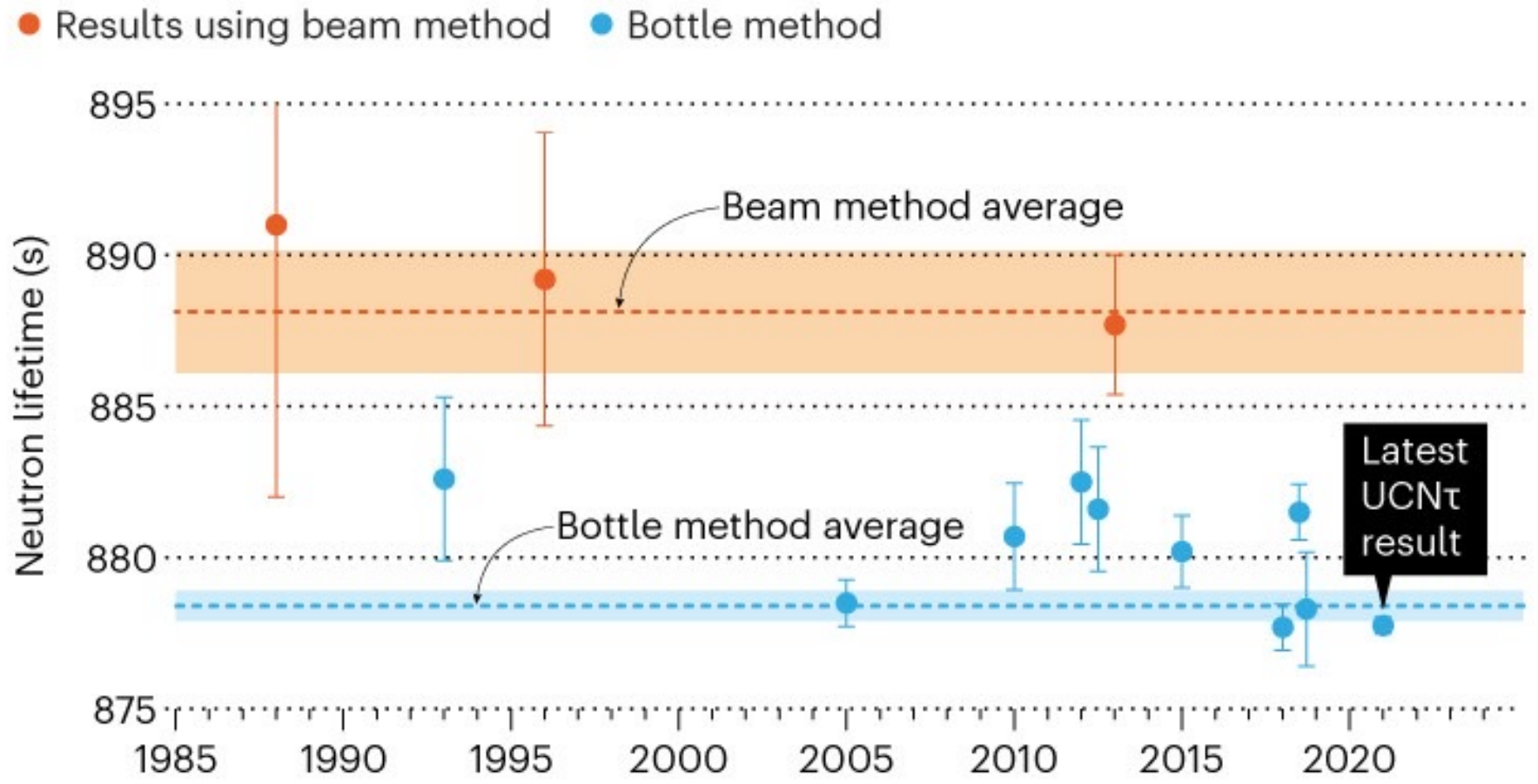

Hadronic weak interaction

Fermions			Bosons	
Quarks	u up	c charm	t top	γ photon
	d down	s strange	b bottom	Z Z boson
	ν_e electron neutrino	ν_μ muon neutrino	ν_τ tau neutrino	W W boson
Leptons	e electron	μ muon	τ tau	g gluon
	Higgs* boson			

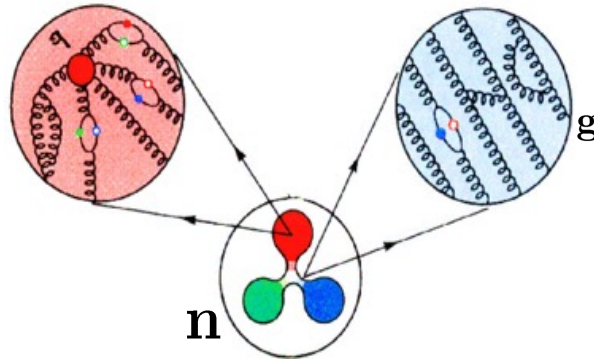

Strong Interaction

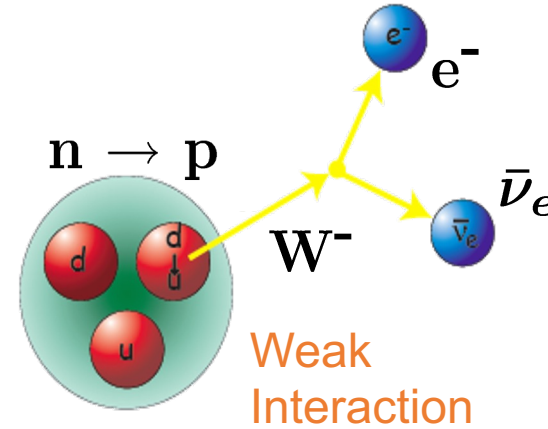

Weak Interaction

Matter is composed of quarks and leptons, which interact through the exchange of bosons (force carriers). The nuclear force (between neutrons and protons) is a residual effect of both the strong and weak interactions, and can be interpreted as the exchange of quark-antiquark pairs (π , ρ , ω -mesons).

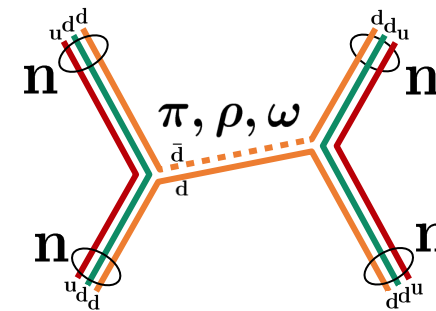

Hadronic Interaction
(residual nuclear force)

$$\sim [g_W^2/M_W^2]/[g_s^2/m_\pi^2] \sim 10^{-7}$$

Polarized neutrons for HWI measurements

- Asymmetry, P violation

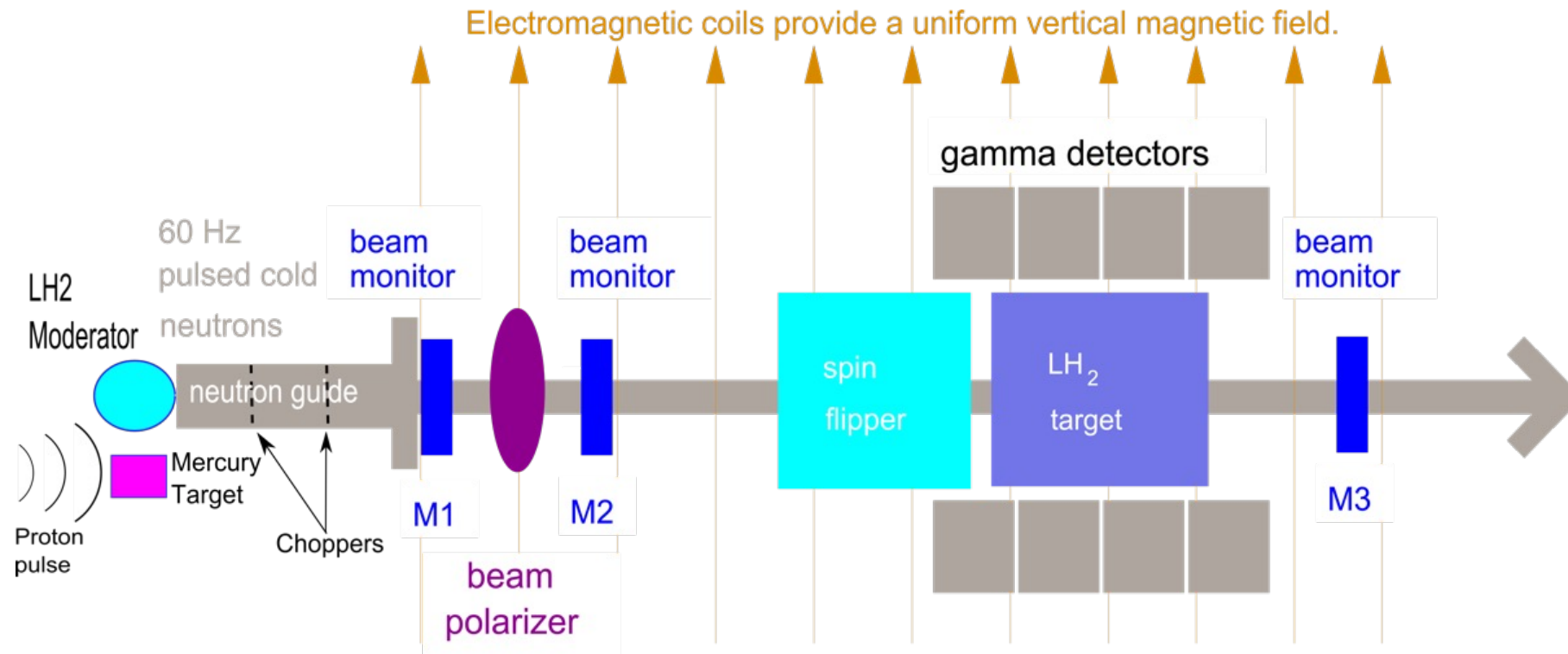
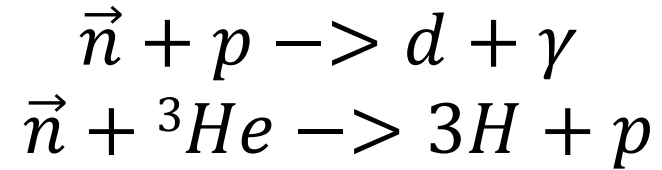

Phys. Rev. Lett. **121**, 242002 (2018)
Phys. Rev. Lett. **125**, 131803 (2020)



Gravity and Quantum effects

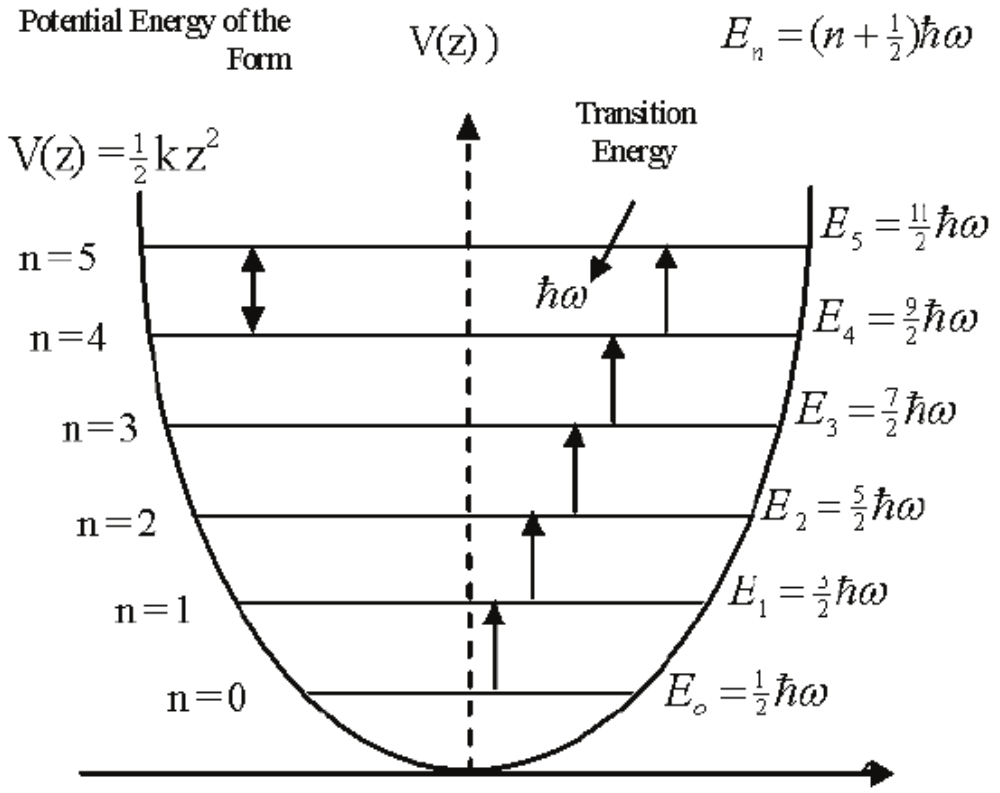
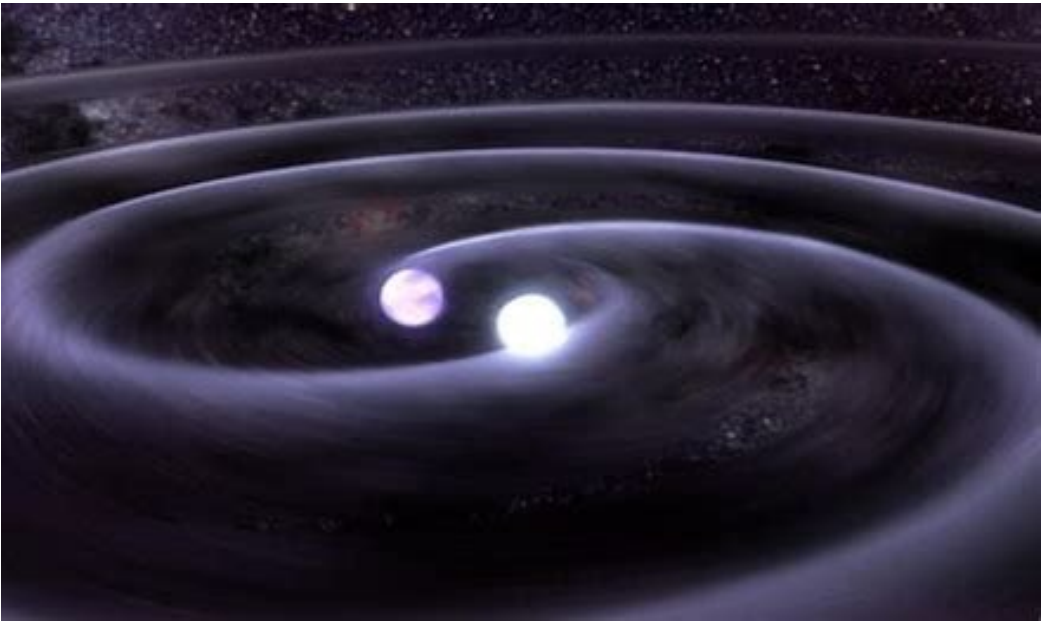



Ultra cold neutron to test quantum gravity

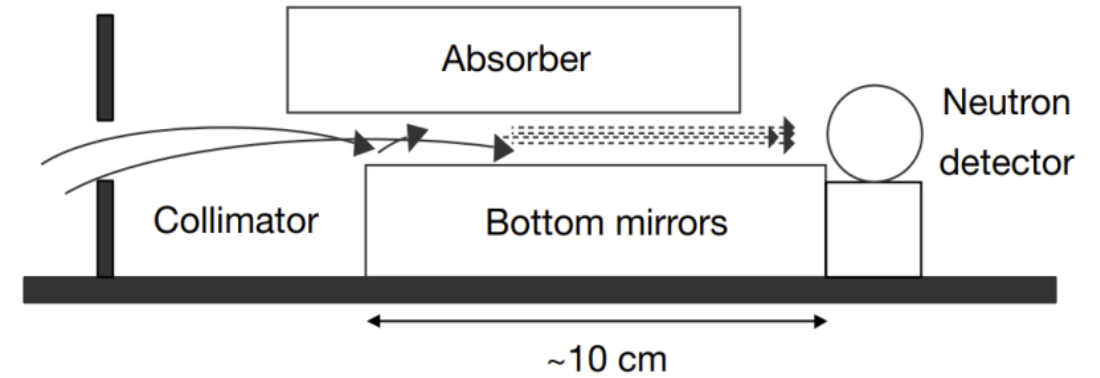
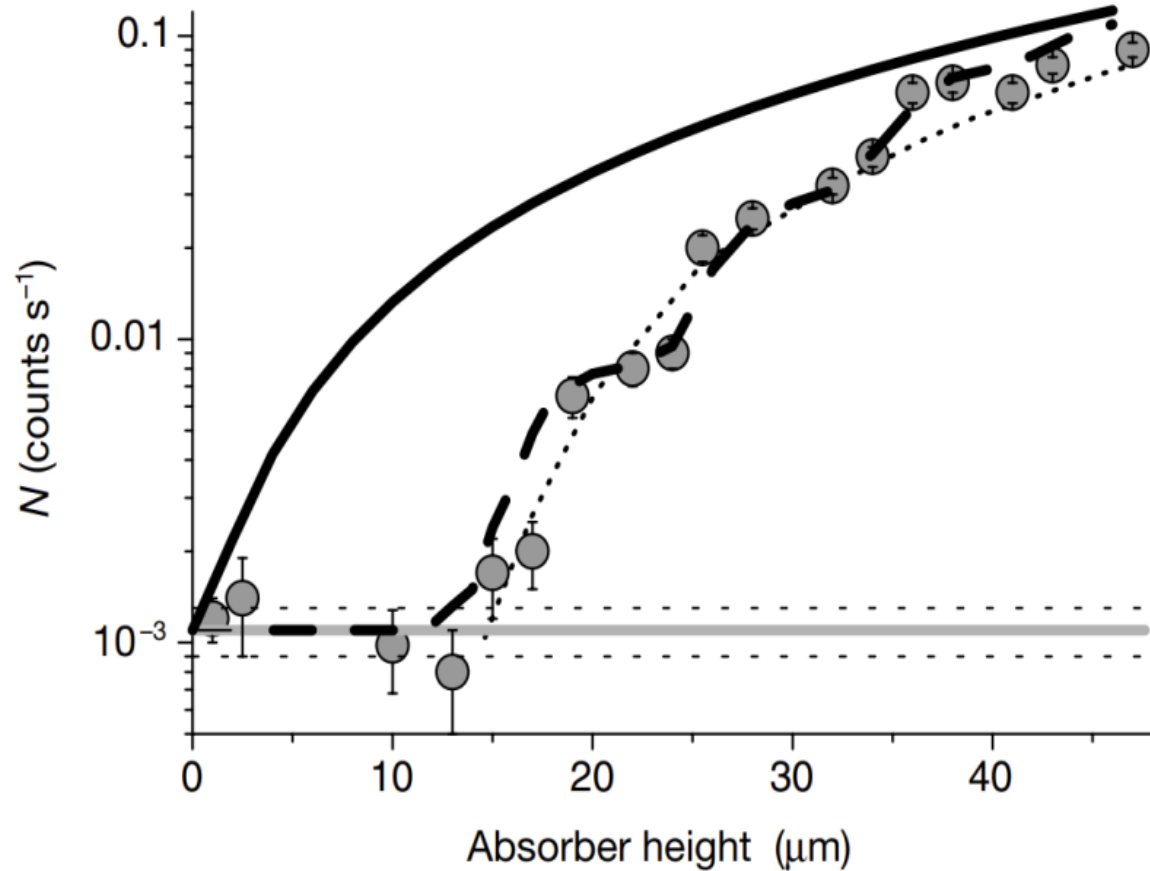

- Test of Newton's gravitation law (Hidden dimension)
- Spin-dependent new forces

Nature **415**, 297(2002)

Weak Axial Vector Coupling

A: the β -asymmetry coefficient

B: the neutrino-asymmetry coefficient

C: the correlation between neutron spin and proton momentum

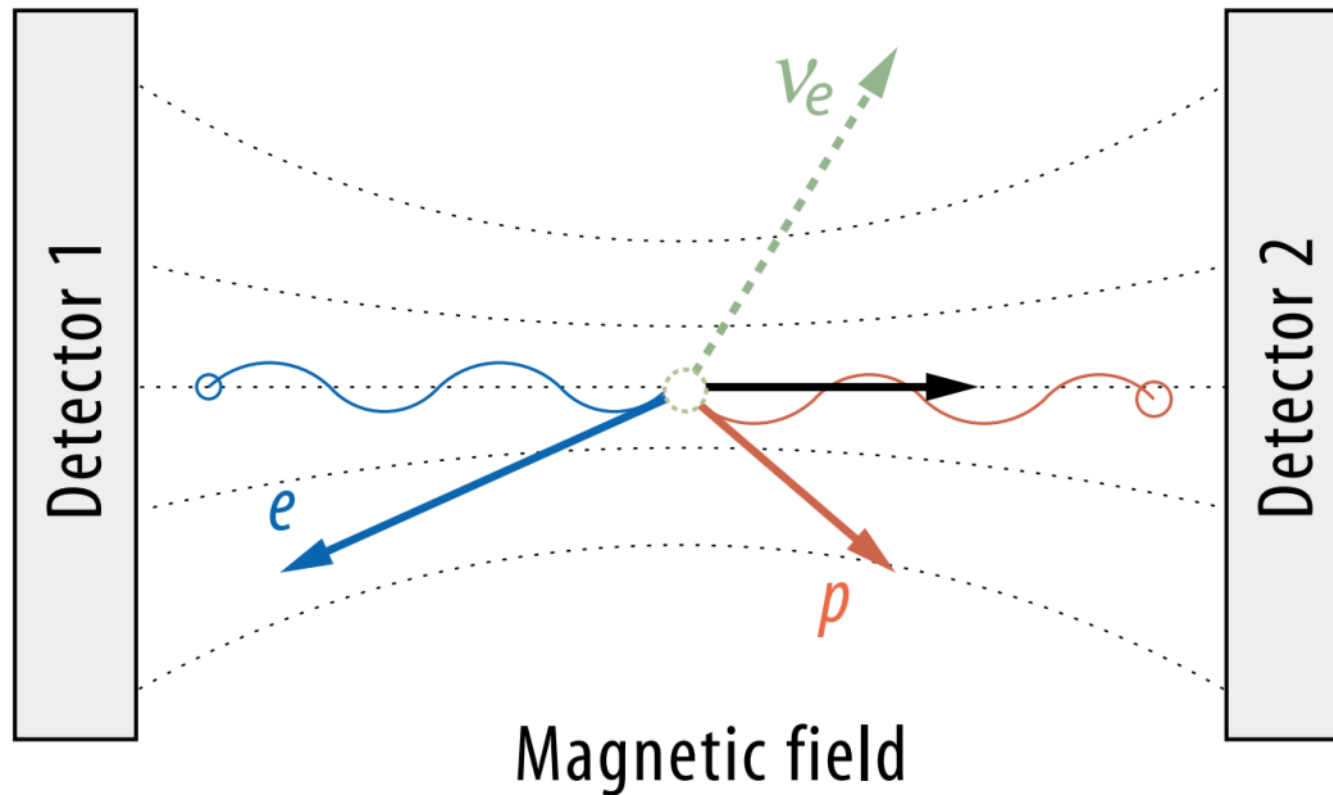

Phys. Rev. Lett. **110**, 172502 (2013)
Phys. Rev. Lett. **100**, 151801 (2008)
Phys. Rev. Lett. **99**, 191803 (2007)

Neutron interferometer to measure spinors

$$I_0 = |\psi_0(0) + \psi_0(\alpha)|^2 = 2|\psi_0^I|^2 \left(1 + \cos \frac{\alpha}{2}\right)$$

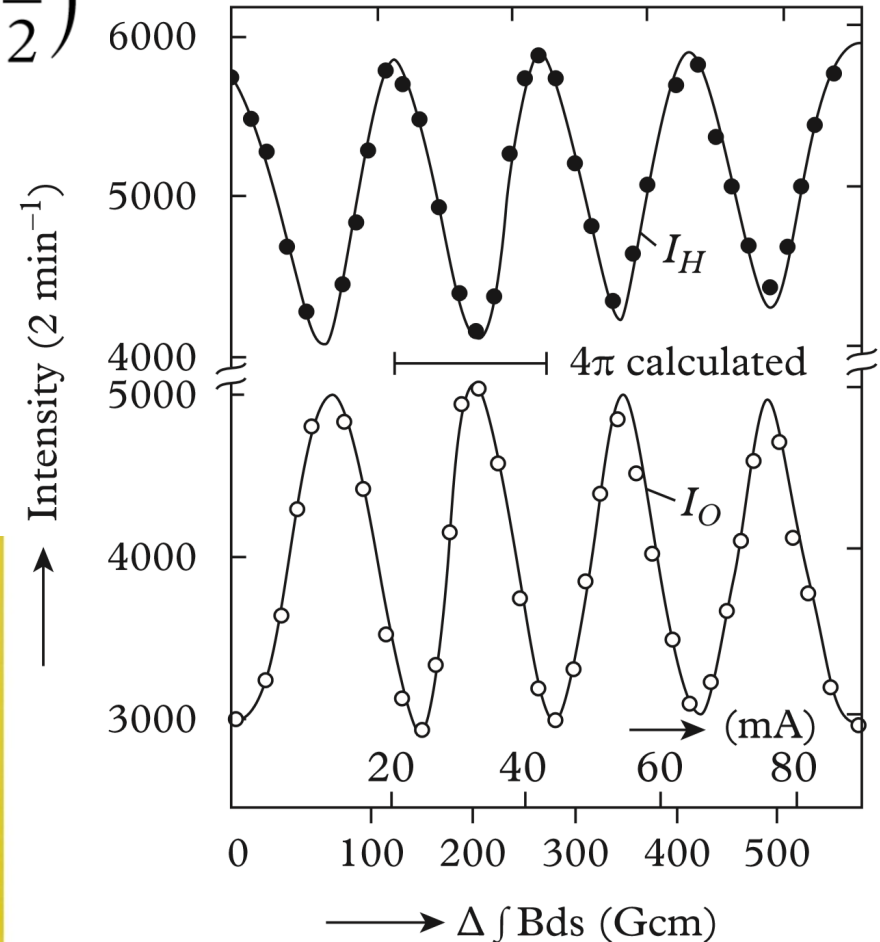
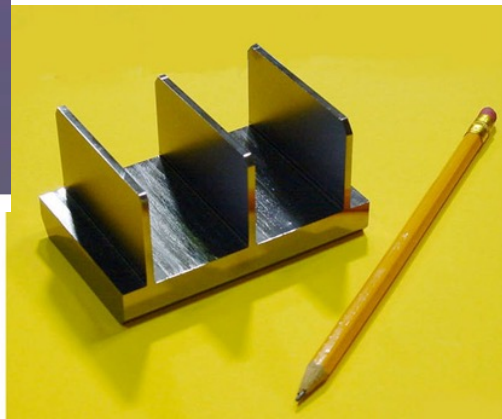
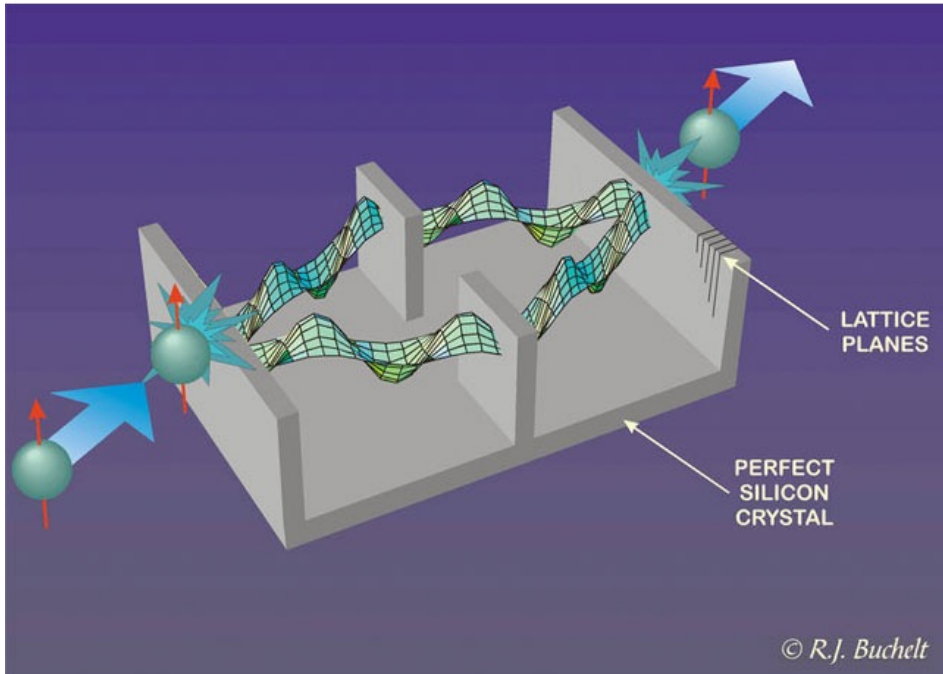

Test of Bell's inequality

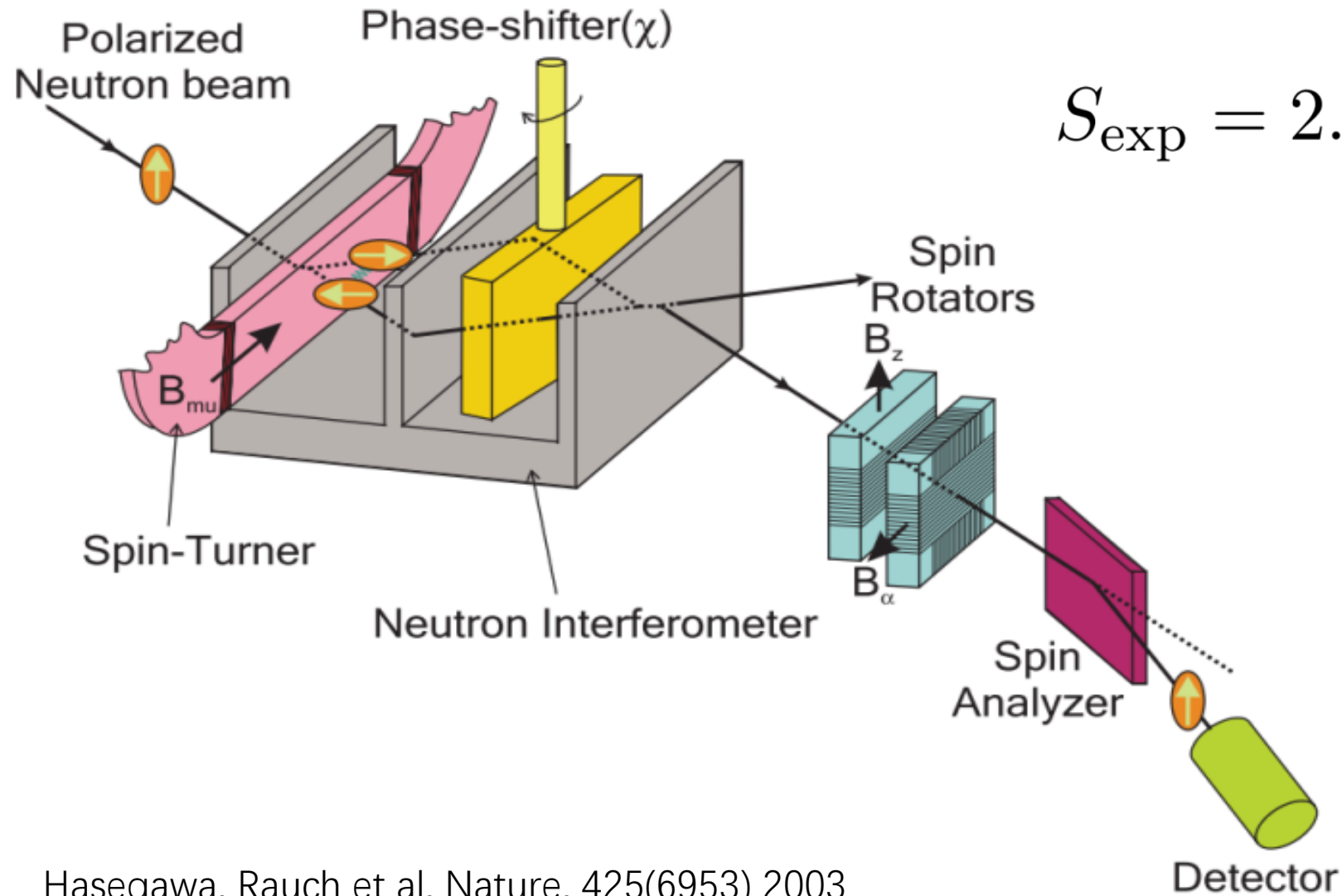

$$S_{\text{exp}} = 2.051 \pm 0.019 \not\leq 2$$

Hasegawa, Rauch et al. Nature, 425(6953) 2003

Neutrons for turbulence visualization

超流氦湍流的可视化——开辟中子研究高雷诺数湍流的新领域

利用低能中子束，首次在超流氦流体内部，观测到中子激发产生的亚稳态 $^4\text{He}_2^*$ 团簇发光，并通过对荧光团簇的追踪，获得了流场的运动轨迹，有望在高雷诺数流体的研究中提供实验依据。

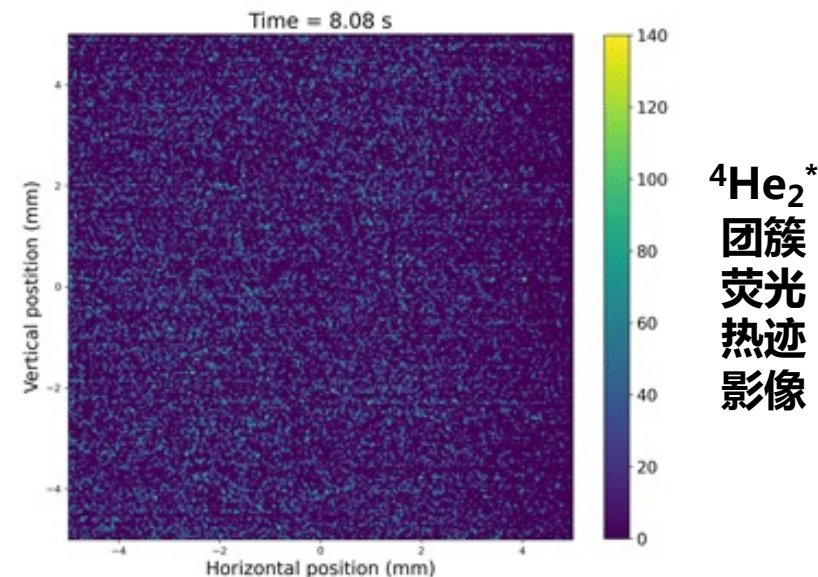
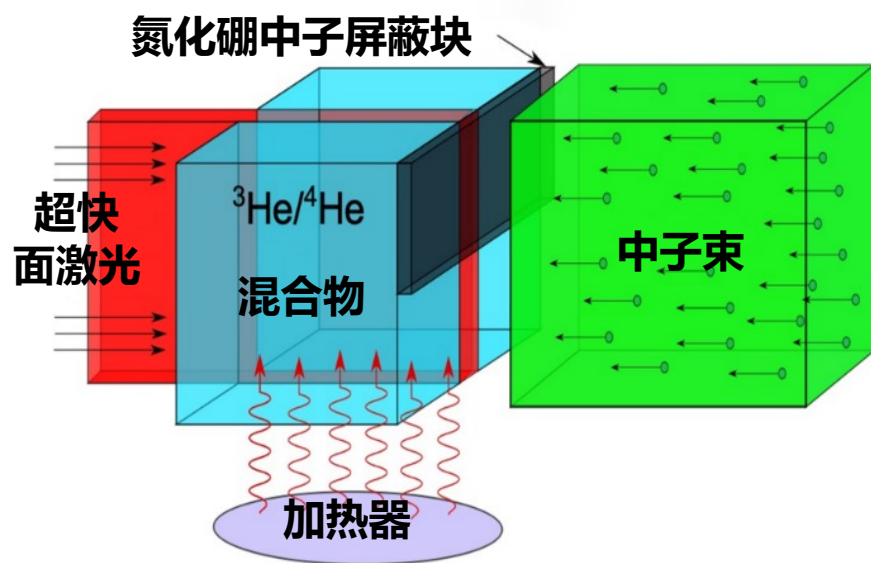

Phys. Rev. Lett., 124, 134502 (2020)



An incomplete list of neutron experiments

- Neutron interaction with the Earth's gravitational field **GRAVITY**
- Correlations in neutron decays **WEAK INTERACTION**
- Limits on neutron charge **E&M**
- Determinations of neutron scattering lengths **STRONG INTERACTION**
- Determinations of neutron magnetic moment **E&M**
- Limits on possible new short range interactions **???**
- Search of neutron anti-neutron oscillations **BAU**
- Search for other sources of time-reversal violation **CPT**
- Neutron's Weak coupling with nucleons **WEAK INTERACTION**
- Search for a non-zero neutron electrical dipole moment **E&M, CPT**
- Determination of neutron lifetime **???**



Production of polarized neutrons

Methods to produce polarized neutrons

Single Crystal Monochromators



Polarizing Supermirrors



Polarized ^3He Target

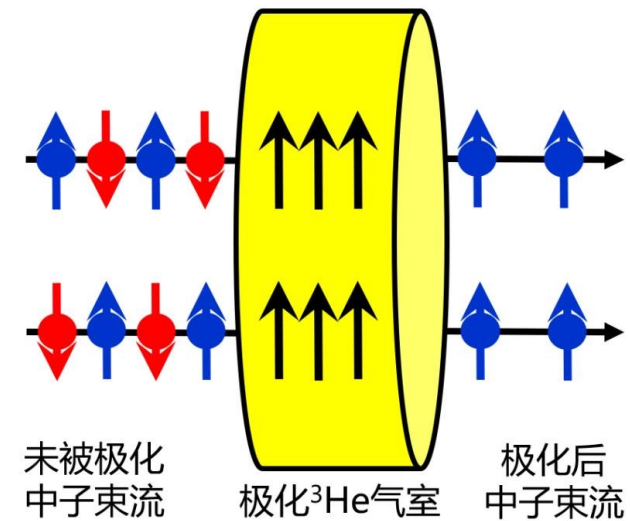

SEOP ^3He neutron spin filter systems at CSNS

SEOP method is a major way of utilizing polarized ^3He for neutron spin filtering

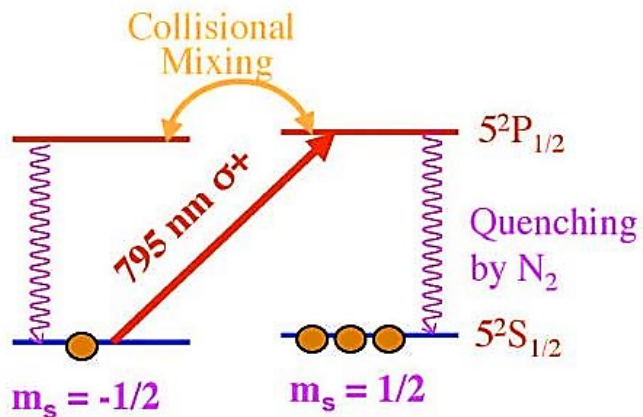

1. Laser pumping Alkali atom electron

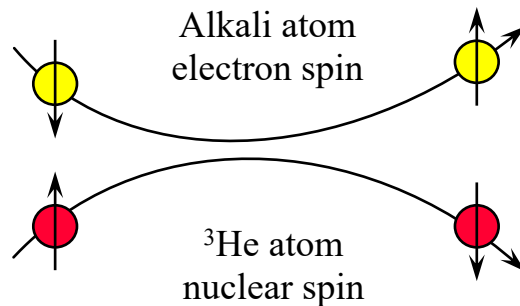

2. Exchange polarization to ^3He atom

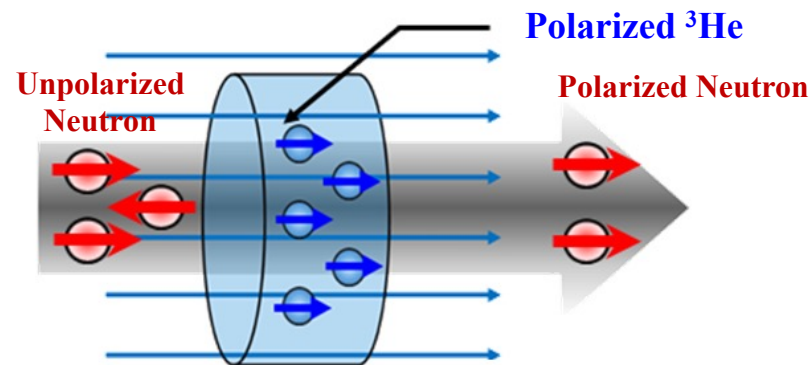

3. Neutron spin filtering by polarized ^3He



SEOP glass cell containing ^3He gas

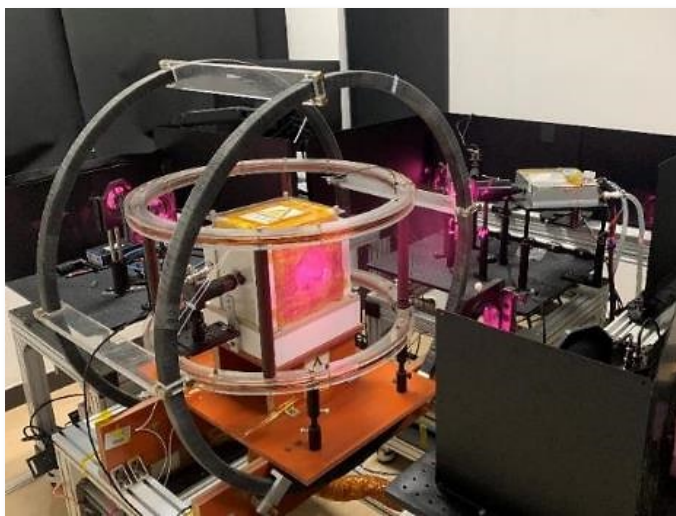

Off-situ SEOP pumping station

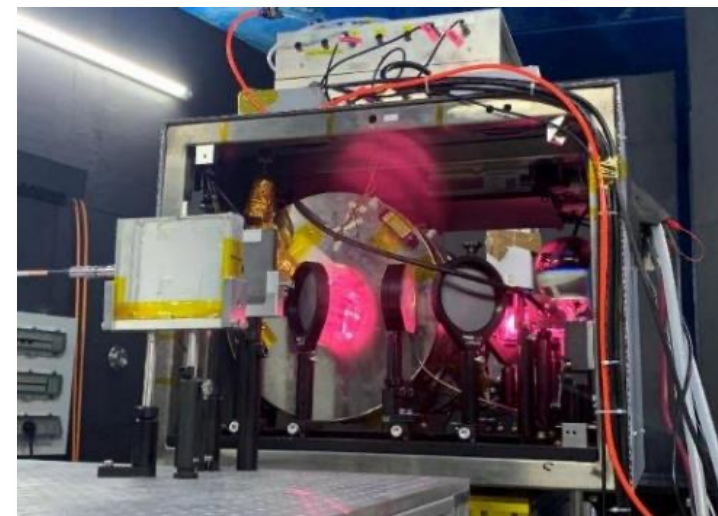

In-situ SEOP Neutron spin filter system

Polarized ^3He Magnetometer and Co-magnetometer

- cryogenic compatibility
- similar magnetic moments with neutrons
- frequency resolution of 7 nHz

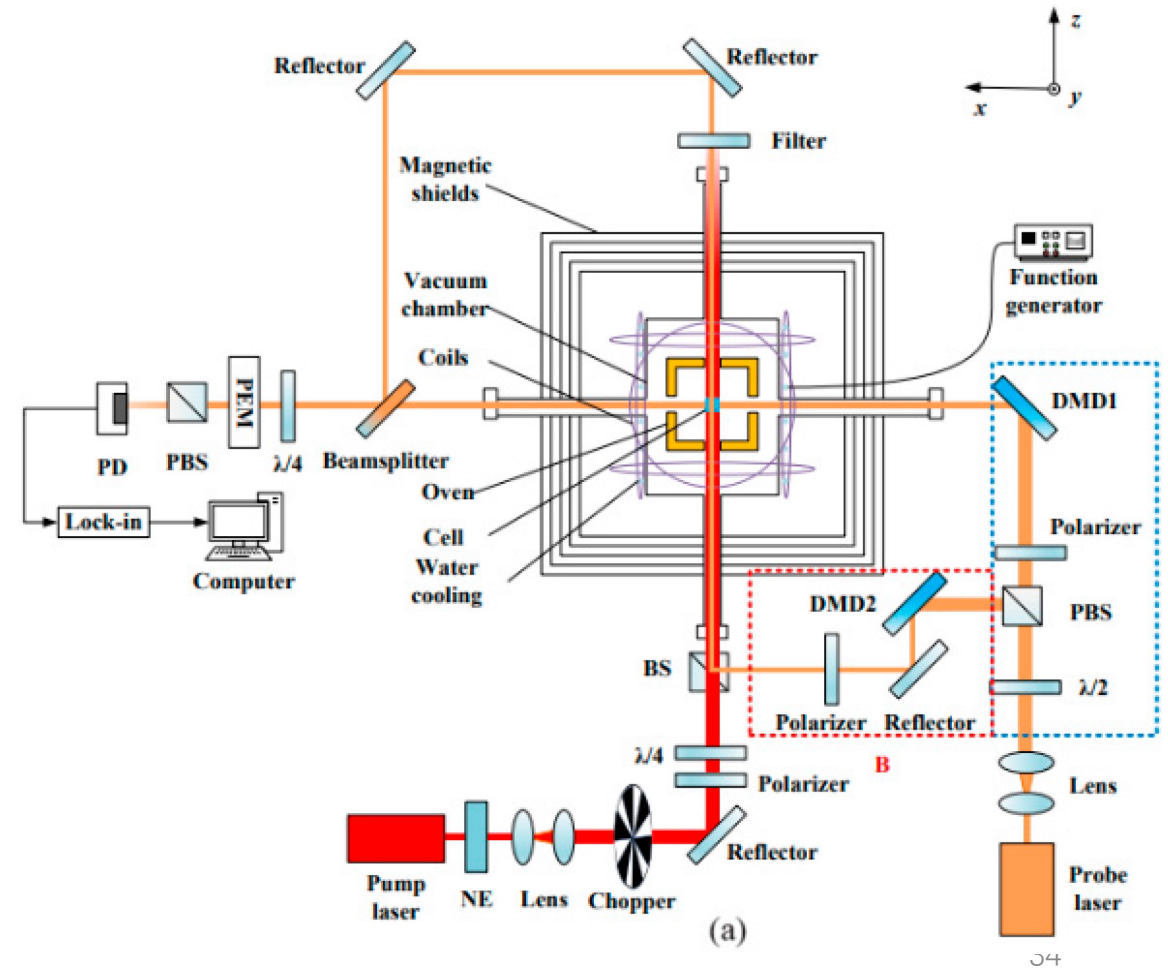
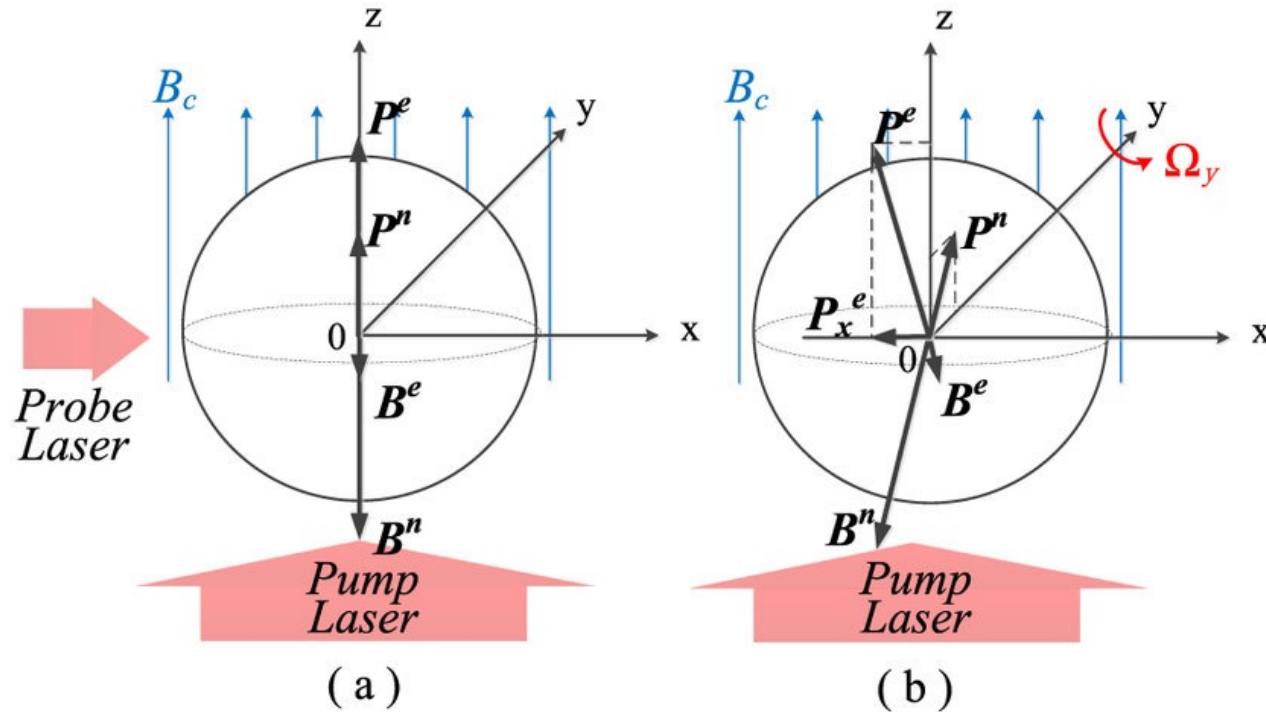



It is so named after the eponymous American laundry detergent, using the axial anomaly to clean up the mess of CP symmetry in the strong interactions



Frank Wilczek
2004 Nobel in Physics

Phys. Rev. Lett. 40, 279 (1978)
Phys. Rev. Lett. 111, 100801 (2013)
Phys. Rev. Lett. 133, 191801 (2024)

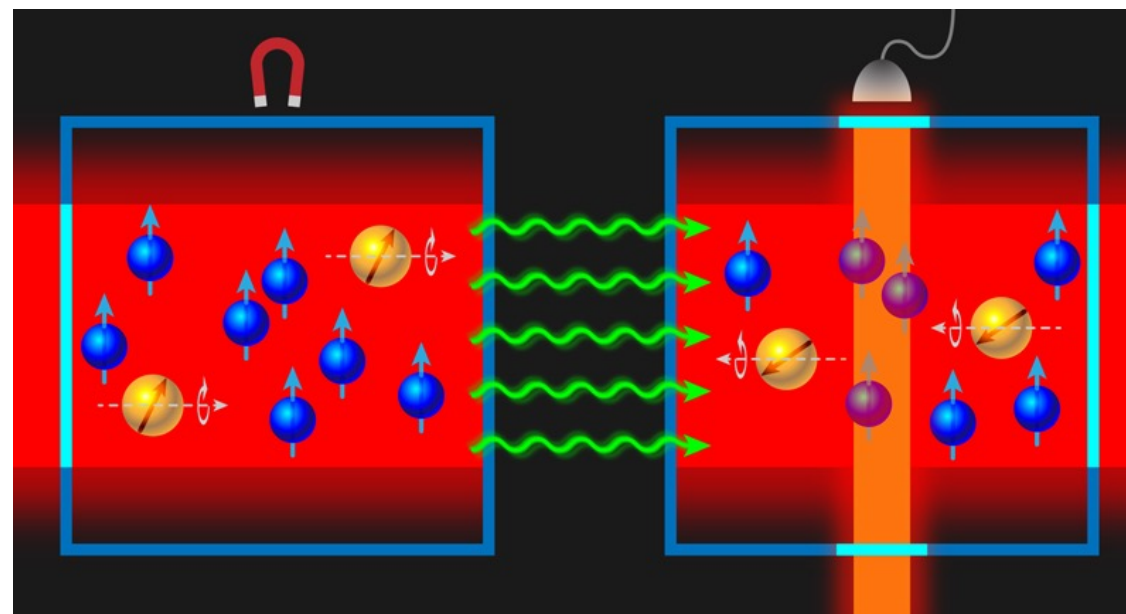



Polarized ^3He as a Neutron Target

- Polarized DIS crucial for study of neutron spin structure
 - PPDFs; tests of QCD, Bjorken sum rule; higher energies

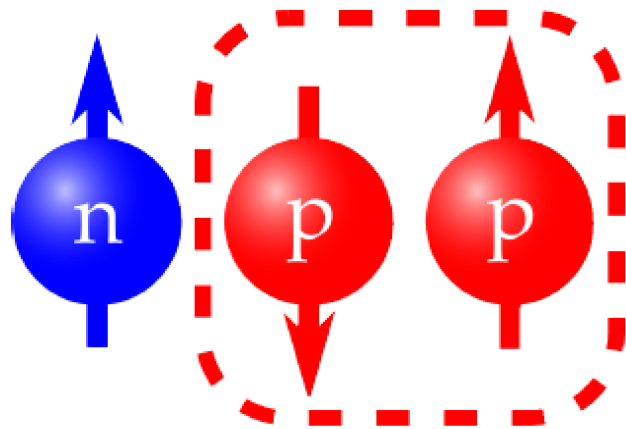

State	Probability
S	88.6%
S'	1.5%
D	8.4%

- S-state ^3He : nuclear spin carried by the neutron
- ^3He 's magnetic moment close to n, compatible with RHIC spin manipulation
- Polarized ^3He ions offer a “polarized neutron beam” for RHIC and a future EIC

Polarized $^3\text{He}^{++}$ ion beam

Identified as high priority R&D for EIC by EICAC review in 2009, Office of Nuclear Physics Community Review in 2017, and the 2018 assessment of the US National Academy of Sciences.

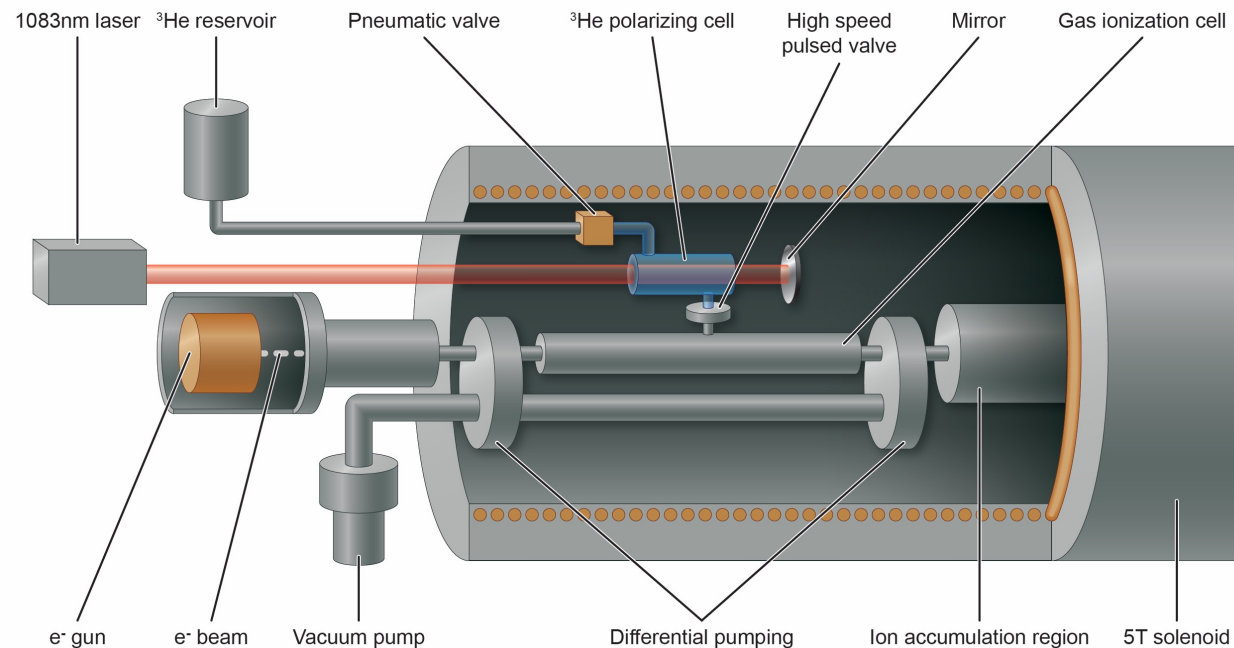
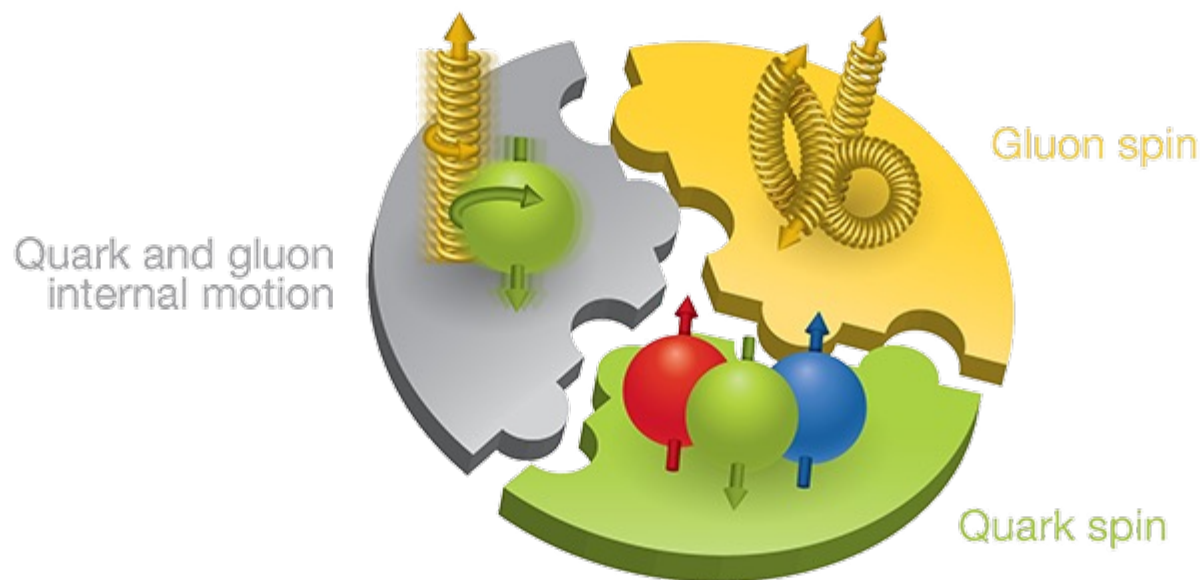



Polarized ^3He program at Jlab (from J.P. Chen)

- **Neutron Spin Structure**

Valance quark: A1n, E99-117

GDH sum rule: E94-010, E97-110

Quark-hadron duality: E01-012

Higher-twist, g_2/d_2 : E97-103, E06-014

Reviews:

Sebastian, Chen, Leader,

PPNP 63 (2009) 1;

J. P. Chen, IJMPE 19 (2010) 1893

- **Single Target Spin Asymmetries**

Transversity and TMDs: E06-010

$2-\gamma$ exchange, Inclusive A_y : E05-015, E07-013

- **^3He Spin/Wave Function Study**

A_x/A_z in QE: E05-102; A_y in QE: E08-005

- **From Factors**

GMn: E95-001;

GEn: E02-013



Neutron Spin Structure (from G. Cates)

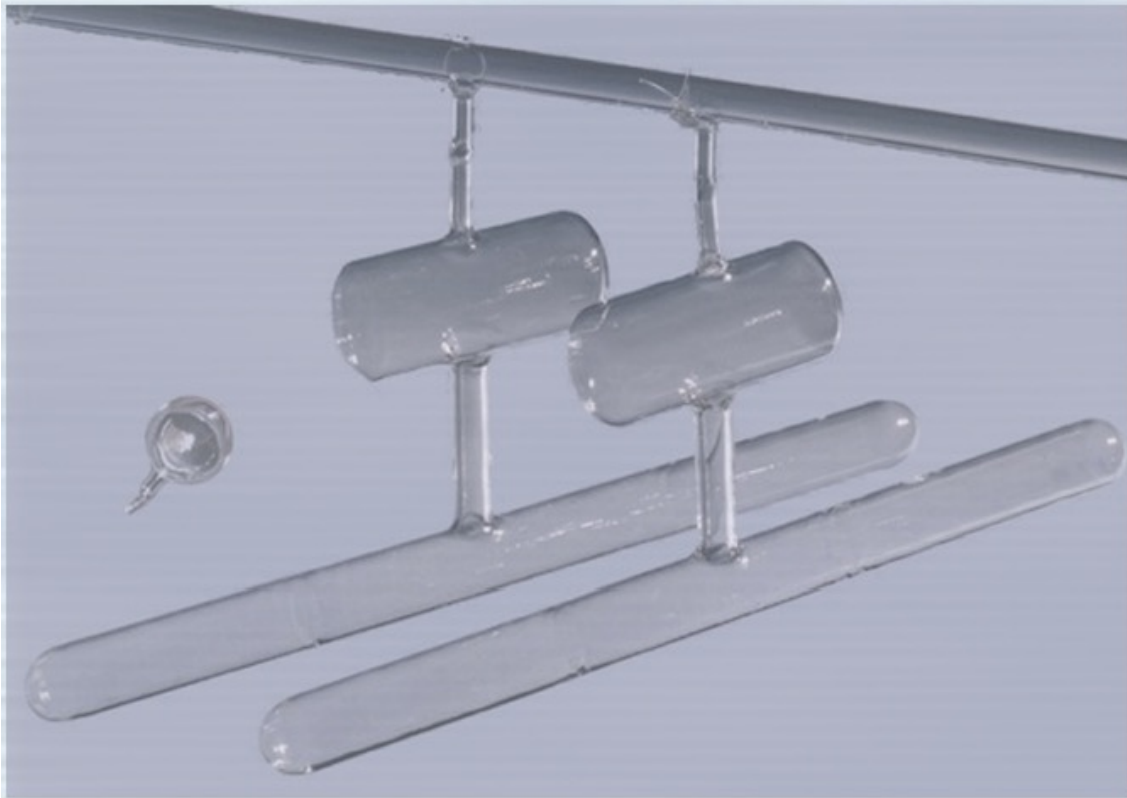

With volumes of 150-200 cc's and nearly 10 atmospheres, these targets contained 1-2 STP liters of gas.

To this day, the data from E142 and E154 provide the most accurate data on the spin structure functions of the neutron over the kinematic range studied.

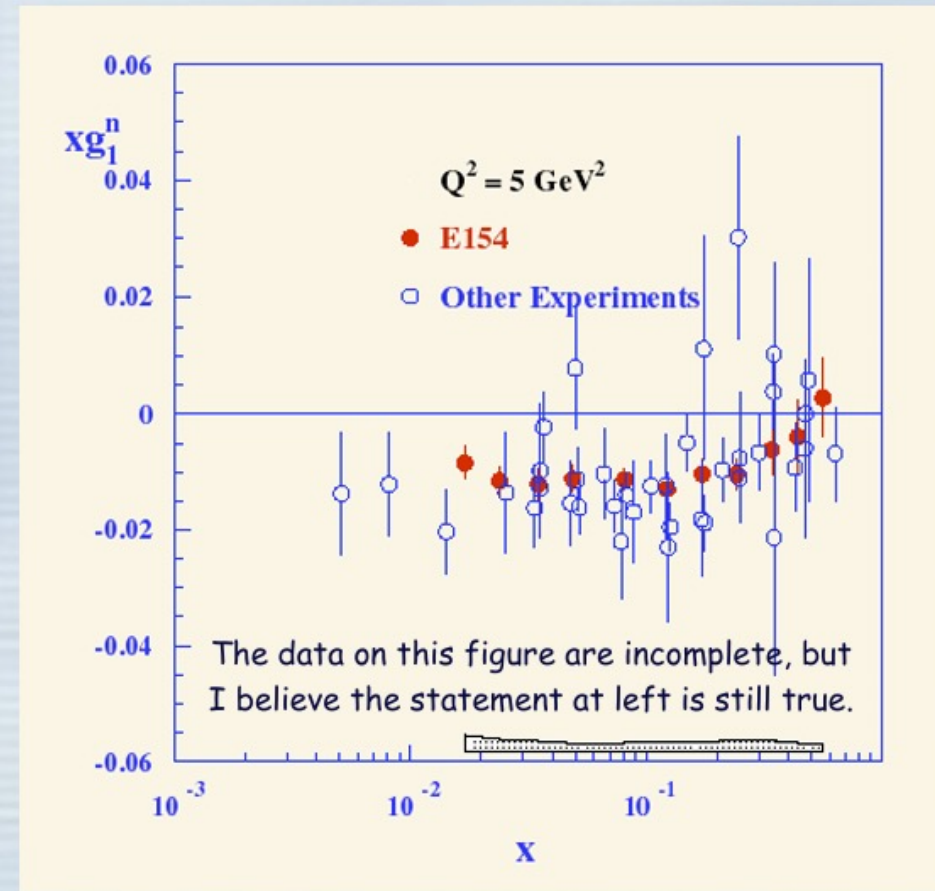

T-violation experiment with polarized neutron and ^3He

□ The CSNS in-situ ^3He system is compatible for epithermal (eV) neutron experiment

Developing SEOP Polarized ^3He for epithermal neutron (740meV) spin filtering allows application in search for Parity-odd Time-reversal-odd interactions

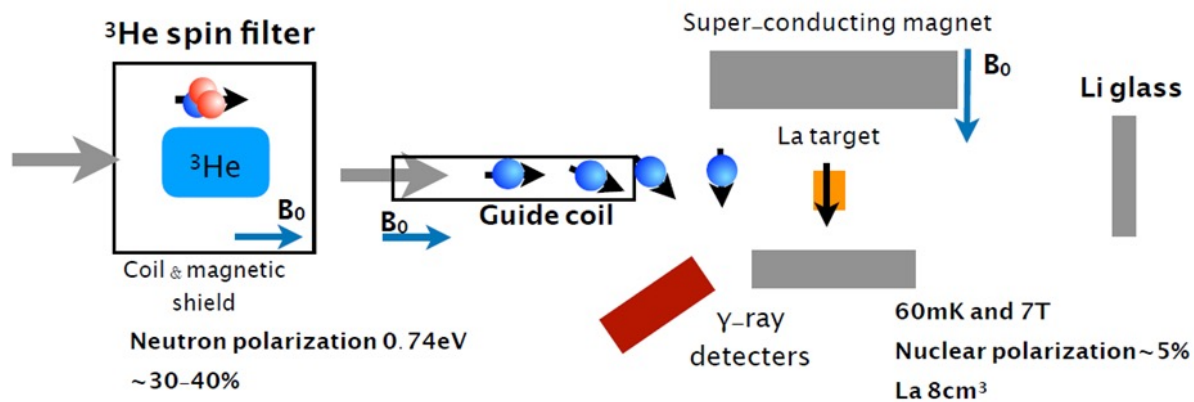

$$f = \underbrace{A'}_{\substack{\text{Spin Independent} \\ \text{P-even T-even}}} + \underbrace{B' \sigma \cdot \hat{I}}_{\substack{\text{Spin Dependent} \\ \text{P-even T-even}}} + \underbrace{C' \sigma \cdot \hat{k}}_{\substack{\text{P-violation} \\ \text{P-odd T-even}}} + \underbrace{D' \sigma \cdot (\hat{I} \times \hat{k})}_{\substack{\text{T-violation} \\ \text{P-odd T-odd}}}$$

Preliminary setup at CSNS back-n beamline using in-situ ^3He

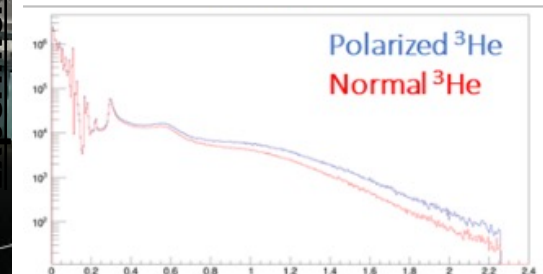
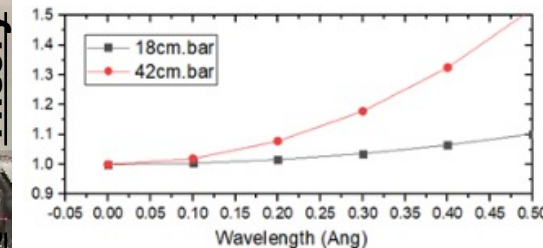

Mofan Zhang, X. Tong*.et. al; First Use of a Polarized ^3He Neutron Spin Filter on the Back-n White Neutron Source of CSNS. ; <https://doi.org/10.48550/arXiv.2409.16598>



- The neutron exhibits much of the richness of nuclear physics, but is vastly simpler, and thus more interpretable, than complex nuclei.
- The neutron can be used to probe Strong, Weak, EM Gravitational as well as quantum phenomena.
- Neutron decay is the archetype for all nuclear beta decay and is a key process in astrophysics.
- The neutron is well suited as a laboratory for tests of physics beyond the Standard Model.

The neutron is complicated enough to be “interesting” , but simple enough to be understandable.