

CEPC CMOS Strip Tracker

Xin Shi

On behalf of CMOS Strip Tracker Team

2025.01.03

CMOS Strip Barrel Module Design

- 单个模块采用倾角斜铺

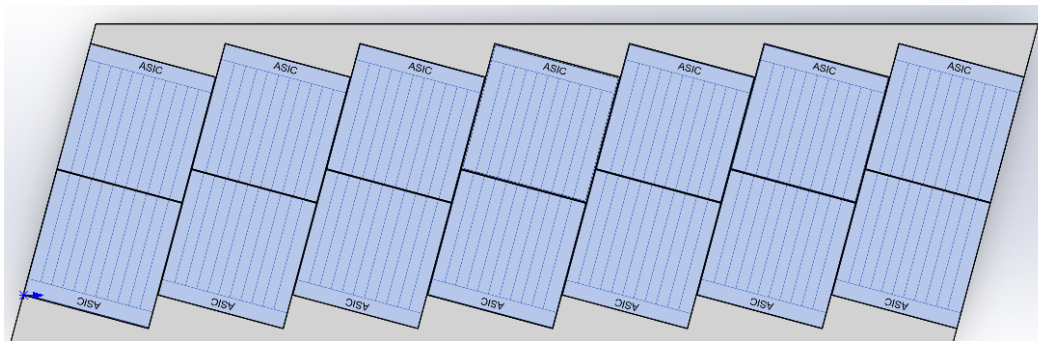

- 四层微条模块交错 30°

$\sigma_{\phi} \sim 4.3 \mu\text{m}$
 $\sigma_z \sim 15.8 \mu\text{m}$

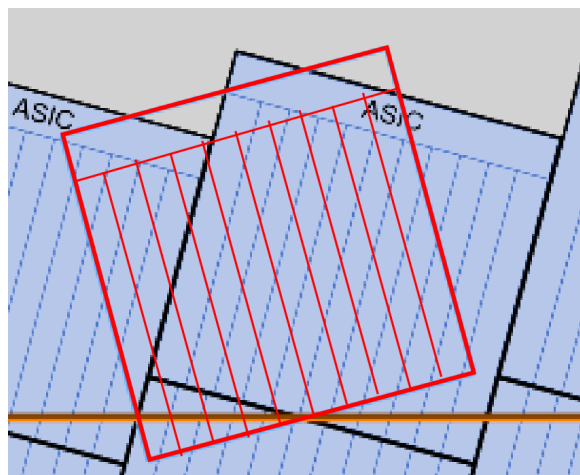

- 两层模块覆盖达到无探测死区

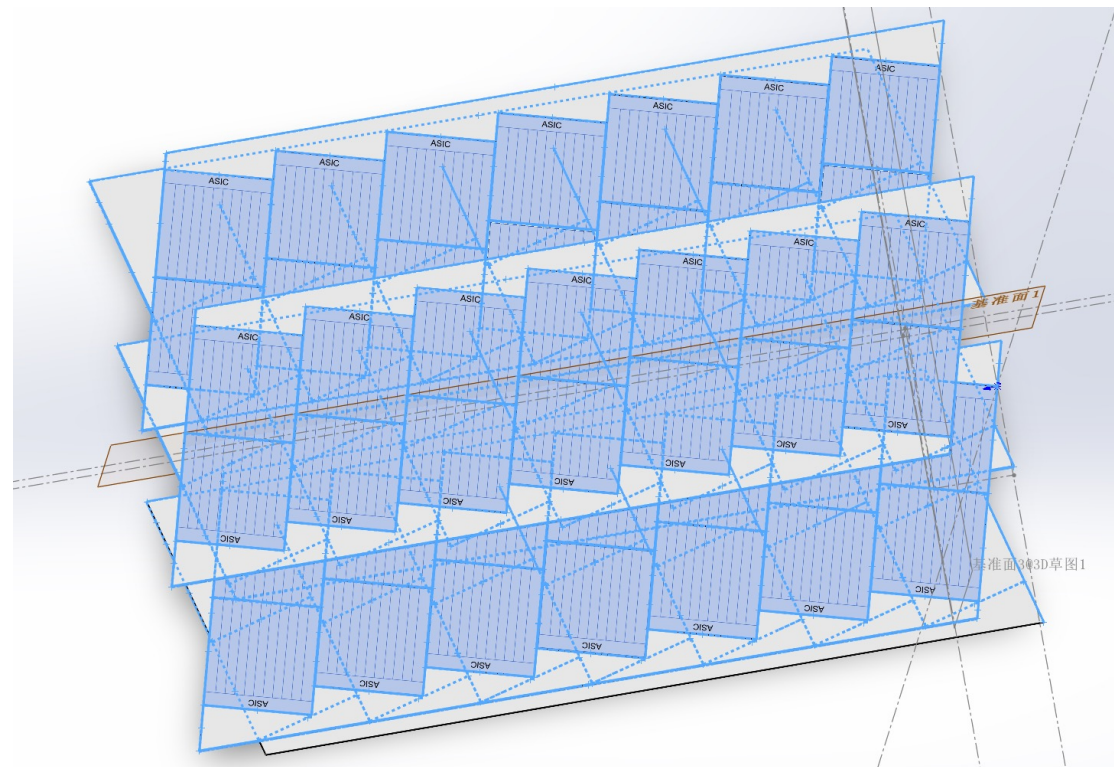

正在进行中： 更新Ref-TDR内容

AFE 版图更新

- 完成带隙基准电路的版图设计

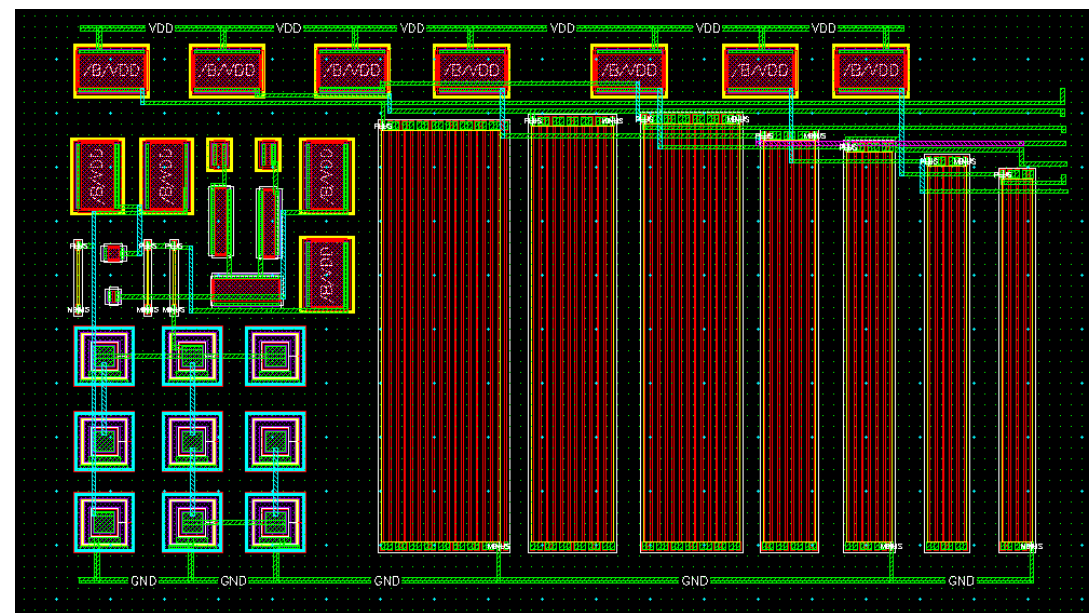
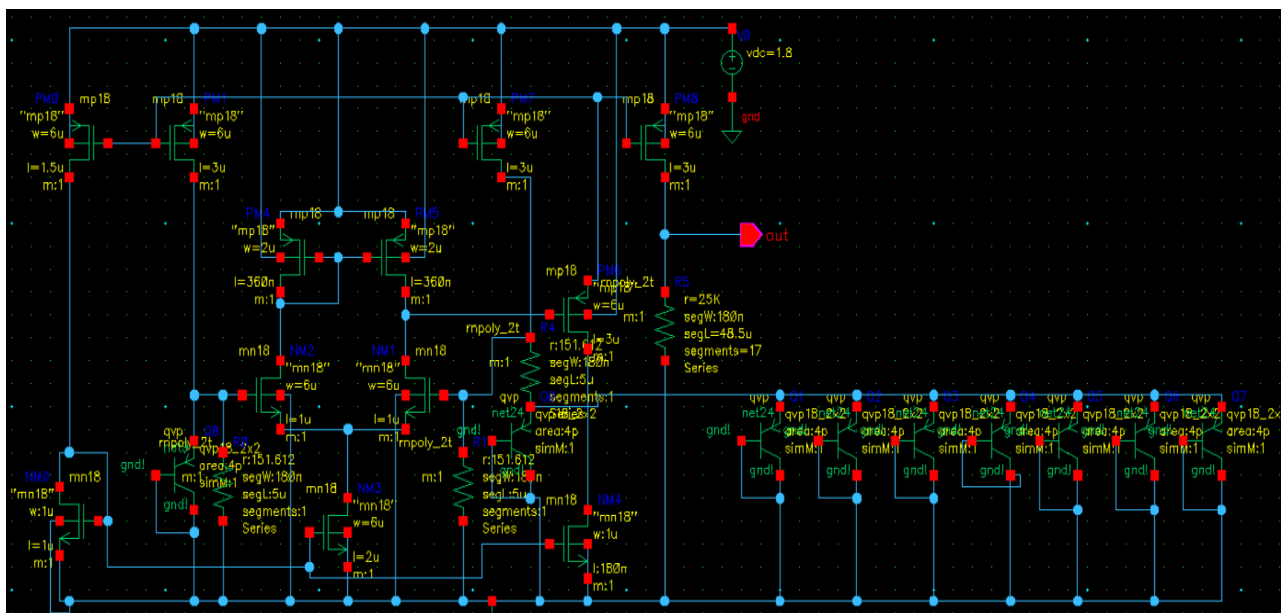

正在进行中：设计 50 μm 窄间距传感器