

# CEPC Silicon Tracker Ref-TDR Overview

Qi Yan *on behalf of the Silicon Tracker Group*

Feb 25, 2025, IHEP

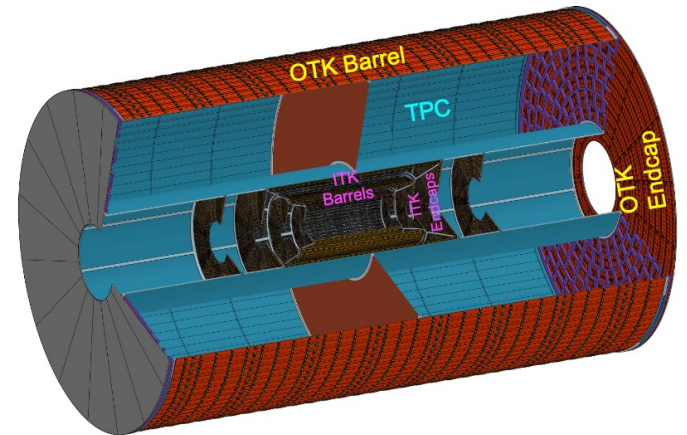

# CEPC Ref-TDR Silicon Tracker章节概况

致力于完成一个合理自洽的 Silicon Tracker 技术性设计报告（Ref-TDR）。Silicon Tracker 章节的全部内容超过100页，是Ref-TDR中最大的一个章节。全部撰写工作需要在本月前完成，以应对4月份的国际评审。目前时间紧、任务重。

当前Ref-TDR填充完成的内容超过90%，剩下的少部分内容正在抓紧补充。希望能最终达到一定的技术水平，在能力范围内做到最好。虽然不能尽善尽美，也有许多不足的地方，请大家谅解。

特别感谢叶竞波、王所近期在阅读后提供的宝贵反馈意见，我们正在抓紧时间修改。也欢迎更多的人能花时间多读一读、提供建设性的意见，帮助一起更好地完成这部分的内容。

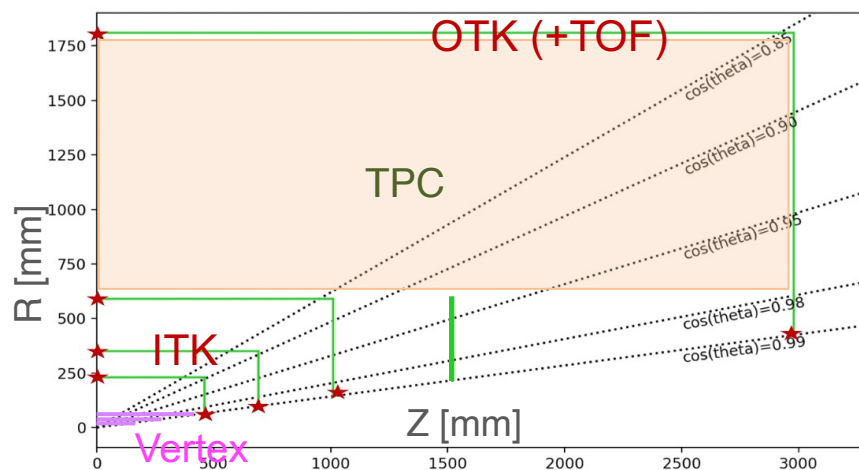
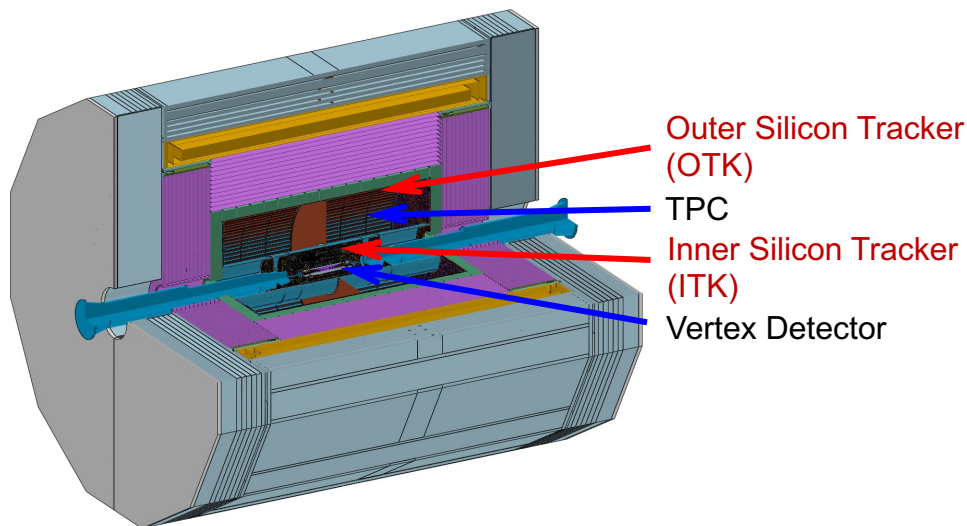

# Outline of Silicon Tracker Ref-TRD

## Chapter 5 Silicon Trackers 总负责人: 严琪

5.1	Requirements	1
5.1.1	Physics requirements	1
5.1.2	Specific requirements on Silicon Tracker	2
5.2	Overview of ITK and OTK	3
5.2.1	Technology options and boundary conditions	4
5.2.2	Optimization tool	4
5.2.3	Layout optimization	4
5.2.3.1	Geometrical envelope of the tracking system	4
5.2.3.2	Layout in Barrel Region	5
5.2.3.3	Layout in Endcap Region	7
5.2.4	Optimization summary	7
5.3	Inner silicon tracker (ITK)	9
5.3.1	CMOS chip R&D	9
5.3.1.1	HV-CMOS pixel R&D	9
5.3.1.1.1	Technology survey for silicon pixel detectors	9
5.3.1.1.2	Development of HV-CMOS pixel sensor for CEPC	10
5.3.1.1.3	COFFEE1	10
5.3.1.1.4	COFFEE2	12
5.3.1.2	CMOS strip R&D	16
5.3.1.2.1	Motivation	16
5.3.1.2.2	Overall design of CMOS strip chip (CSC)	17
5.3.1.2.3	Fast simulation with RASER	20
5.3.2	ITK design	23
5.3.2.1	ITK barrel design	23
5.3.2.2	ITK endcap design	25
5.3.2.3	Alternative design for the ITK	26
5.3.3	Readout electronics	33
5.3.4	Mechanical and cooling design	34
5.3.4.1	Barrel local support	34
5.3.4.1.1	Materials	34
5.3.4.1.2	Structural characterisation	35
5.3.4.1.3	Thermal characterisation	36
5.3.4.2	Endcap local support for HV-CMOS pixel detector	37
5.3.4.2.1	Materials	37
5.3.4.2.2	Structural characterisation	38
5.3.4.2.3	Thermal characterisation	38
5.3.4.3	Endcap local support for CMOS strip detector	38
5.3.4.3.1	Materials	39
5.3.4.3.2	Structural characterisation	39
5.3.4.3.3	Thermal characterisation	39
5.3.5	Prospects and plan	41
5.3.5.1	Development of the CMOS pixel sensor	41
5.3.5.2	Development of the CMOS strip sensor	42
5.3.5.3	Module and system level development	43
5.4	Outer silicon tracker (OTK) with TOF	44
5.4.1	AC-LGAD sensor and ASIC R&D	44
5.4.1.1	AC-LGAD Sensor R&D	44

5.4.1.1	AC-LGAD simulation	45
5.4.1.2	Testing setup	46
5.4.1.3	Pixelated AC-LGAD prototypes	48
5.4.1.4	Strip AC-LGAD prototype and properties	50
5.4.1.2	AC-LGAD ASIC R&D	55
5.4.1.2.1	General requirements	55
5.4.1.2.2	ASIC architecture	56
5.4.1.2.3	Single-channel readout electronics	56
5.4.1.2.4	Data process and digital blocks	59
5.4.1.2.5	Prototype	60
5.4.1.2.6	Power distribution and grounding	63
5.4.1.2.7	Radiation tolerance	63
5.4.1.2.8	Monitoring	64
5.4.1.2.9	Development plan and schedule	64
5.4.2	OTK design	65
5.4.2.1	OTK barrel design	65
5.4.2.2	OTK endcap design	66
5.4.3	Readout electronics	72
5.4.3.1	Front-end board	72
5.4.3.2	Concentrator Card and power distribution	73
5.4.3.3	Slow control and monitoring	73
5.4.3.4	Clock distribution	73
5.4.4	Mechanical and cooling design	74
5.4.4.1	Barrel support	74
5.4.4.1.1	Materials	75
5.4.4.1.2	Structural characterisation	76
5.4.4.1.3	Thermal characterisation	77
5.4.4.2	Endcap support	78
5.4.4.2.1	Materials	80
5.4.4.2.2	Structural characterisation	80
5.4.4.2.3	Thermal characterisation	81
5.4.5	Prospects and plan	82
5.4.5.1	Development of AC-LGAD strip sensor for CEPC	82
5.4.5.2	Development of AC-LGAD readout ASIC	82
5.4.5.3	Development of mechanical and cooling system	83
5.4.5.4	Summary	83
5.5	Beam background estimation	84
5.5.1	Beam background simulation	84
5.5.1.1	Pair production background	84
5.5.1.2	Single beam background	84
5.5.1.2.1	Beam Thermal Photon Scattering (BTH)	84
5.5.1.2.2	Beam Gas Coulomb Scattering (BGC) and Beam Gas Bremsstrahlung Scattering (BGB)	84
5.5.1.2.3	Touschek Scattering (TSC)	85
5.5.2	Hit rate estimation for beam background	85
5.5.3	ITK tolerable hit rate	85
5.5.4	OTK tolerable hit rate	86
5.6	Performance	88
5.6.1	The performance of the barrel region	88
5.6.1.1	Momentum resolution	88
5.6.1.2	Roles of gaseous and silicon trackers	88
5.6.1.3	Particle identification performance	90
5.6.2	The performance of the forward region (endcap)	90
5.6.2.1	Momentum resolution performance	90
5.6.2.2	Particle identification performance	92

# Section 5.1: Requirements

The CEPC is designed to operate across a wide energy region, including Z-pole (91 GeV),  $W^+W^-$  threshold (160 GeV), the energy maximizing  $ZH$  production (240 GeV), and  $t\bar{t}$  threshold after upgrade (360 GeV). In High Lumi Z mode, the luminosity reaches  $\mathcal{L} = 115 \times 10^{34} \text{cm}^{-2}\text{s}^{-1}$  at 30 MW ( $192 \times 10^{34} \text{cm}^{-2}\text{s}^{-1}$  at 50 MW), with a 23 ns interval between bunch crossings. The stringent requirements of both physics and operational conditions impose high demands on the CEPC tracking system.

## 5.1.1 Physics requirements

- Higgs and electroweak physics studies
- Flavor physics, the precise reconstruction of B and D hadrons
- Flavor physics studies and jet substructure analysis

Summarized physics requirements:

- Momentum resolution
- Impact parameter measurement
- Particle identification
- Solid angle coverage

## 5.1.2 Specific requirements on Silicon Tracker

- Layout
- Spatial resolution and material budget
- Timing resolution



# Section 5.2: Overview of ITK and OTK

The layout of the tracker system is crucial for accurately identification and determination of particle trajectories. This section provides an overview of the CEPC tracker system, with a particular focus on the Silicon Trackers and their layout optimization to enhance performance.

## 5.2.1 Technology options and boundary conditions

- Spatial Measurements
- Materials
- Particle Identification (PID) Compatibility

## 5.2.2 Optimization tool

- Lic Toy (LDT): a MatLab software designed to model and optimize the layout of detector taking in to account physical constraints, material budget, and performance metrics.

## 5.2.3 Layout optimization

- Optimization of geometrical envelope of the tracking system
- Optimization of the Layout in barrel region
- Optimization of the Layout in endcap region
- Optimization summary

# Section 5.3: Inner Silicon Tracker (ITK)

## 5.3.1 CMOS chip R&D

- 5.3.1.1 HV-CMOS pixel R&D . . . . .
  - 5.3.1.1.1 Technology survey for silicon pixel detectors . . .
  - 5.3.1.1.2 Development of HV-CMOS pixel sensor for CEPC
  - 5.3.1.1.3 COFFEE1 . . . . .
  - 5.3.1.1.4 COFFEE2 . . . . .
- 5.3.1.2 CMOS strip R&D . . . . .
  - 5.3.1.2.1 Motivation . . . . .
  - 5.3.1.2.2 Overall design of CMOS strip chip (CSC) . . . . .
  - 5.3.1.2.3 Fast simulation with RASER . . . . .

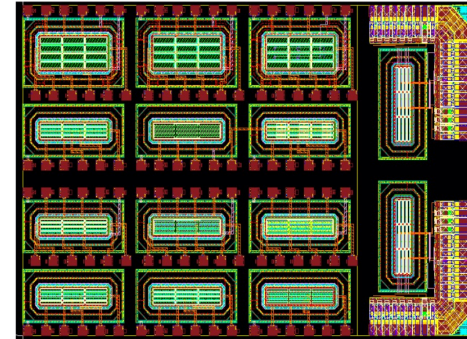

COFFEE1

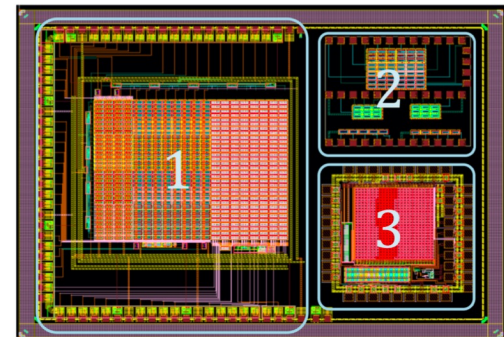

COFFEE2

## 5.3.2 ITK design

- 5.3.2.1 ITK barrel design . . . . .
- 5.3.2.2 ITK endcap design . . . . .
- 5.3.2.3 Alternative design for the ITK . . . . .

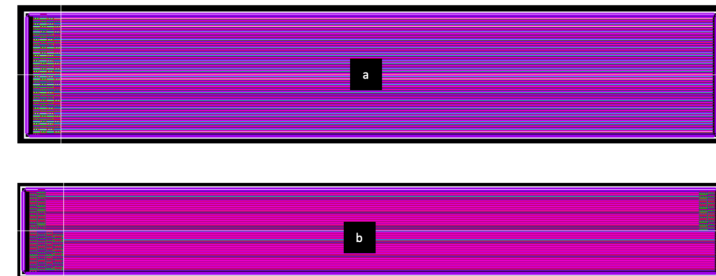

CSC1

# Section 5.3.2.1: ITK barrel design (Baseline)

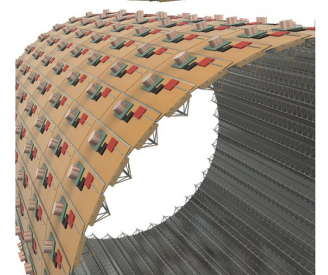
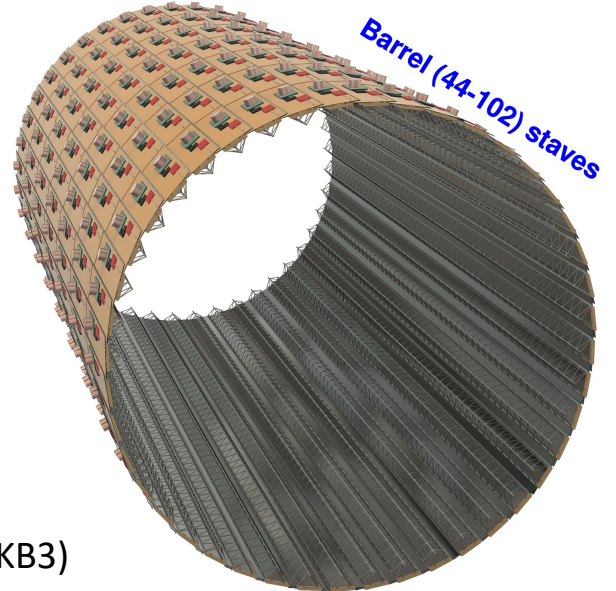
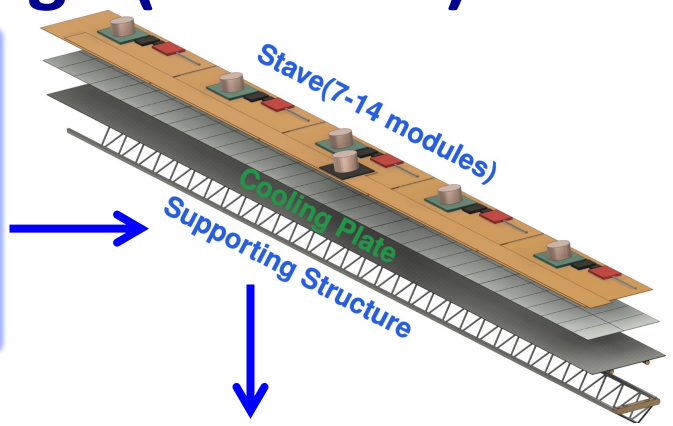
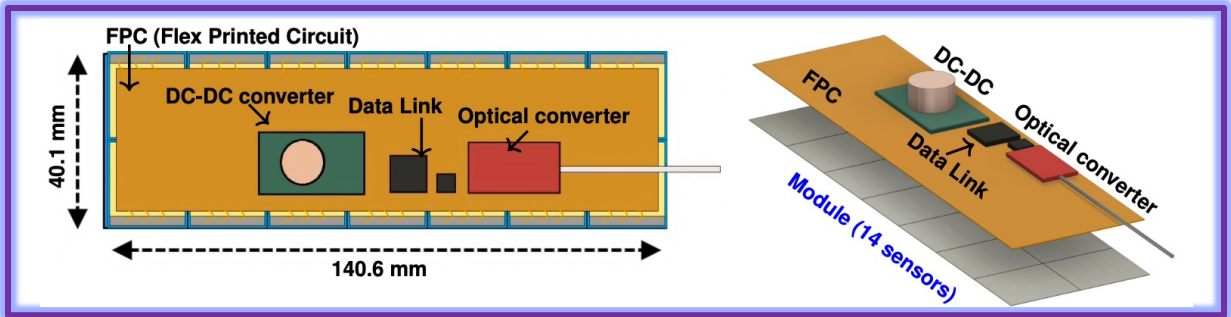

■ **HVCMOS pixel sensor:**

- Sensor size: 20 mm × 20 mm (active area of 17.4 mm × 19.2 mm)
- Array size: 512 rows × 128 columns
- Pixel size: 34 μm × 150 μm (spatial resolution: 8 μm × 40 μm)
- Time resolution: 3-5 ns
- Power consumption: ~200 mW/cm<sup>2</sup>

■ **Module:**

- 14 sensors (2 rows × 7 columns)
- Sensor gap: 100 μm
- Module dimensions: 140.6 mm × 40.1 mm

■ **Stave:**

- Module gap: 300 μm
- Length: 986.6 mm (ITKB1), 1,409.6 mm (ITKB2), and 1973.2 mm (ITKB3)

■ **Barrel radii:** 235 mm (ITKB1), 345 mm (ITKB2), and 555.6 mm (ITKB3)

Information about staves, modules, and sensors used for 3 ITK barrels construction

Barrel	Number of staves	Modules per stave	Sensors per module	Total number of sensors	Sensor area [m <sup>2</sup> ]
ITKB1	44	7	14	4312	1.72
ITKB2	64	10	14	8960	3.58
ITKB3	102	14	14	19992	8.00
Total	210			33264	13.31



# Section 5.3.2.2: ITK endcap design (Baseline)

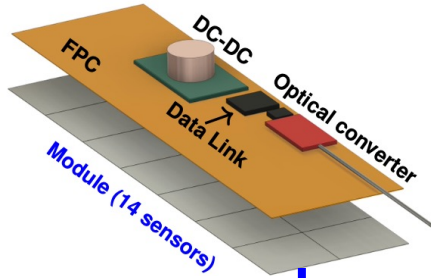

■ **Module:**

- 3 types of modules: 8, 12, and 14 sensors for all 4 ITK endcaps

■ **Endcap active area radii:**

- $81.5 \text{ mm} < r < 242.5 \text{ mm}$  (ITKE1),  $110.5 \text{ mm} < r < 352.3 \text{ mm}$  (ITKE2),  $163 \text{ mm} < r < 564 \text{ mm}$  (ITKE3), and  $223 \text{ mm} < r < 564 \text{ mm}$  (ITKE4)

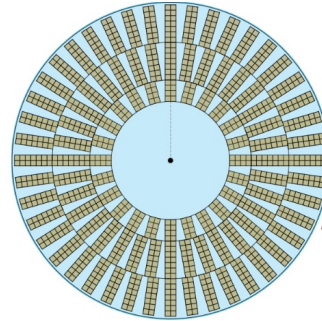
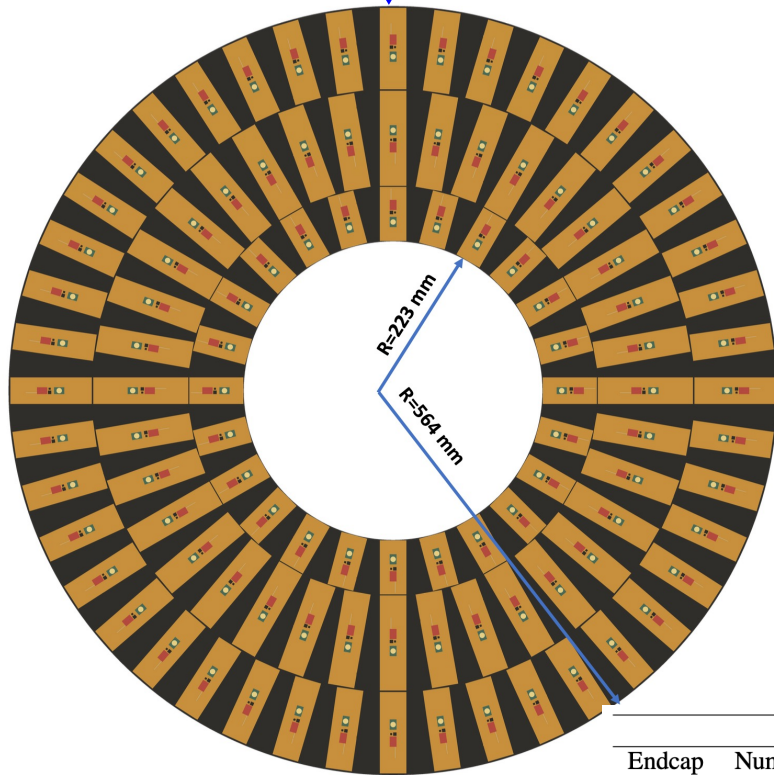

Front view of endcap

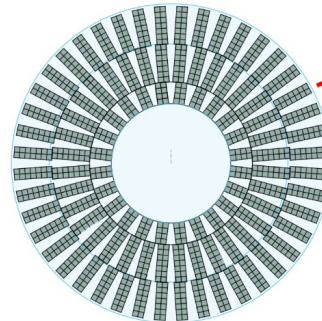

Back view of endcap

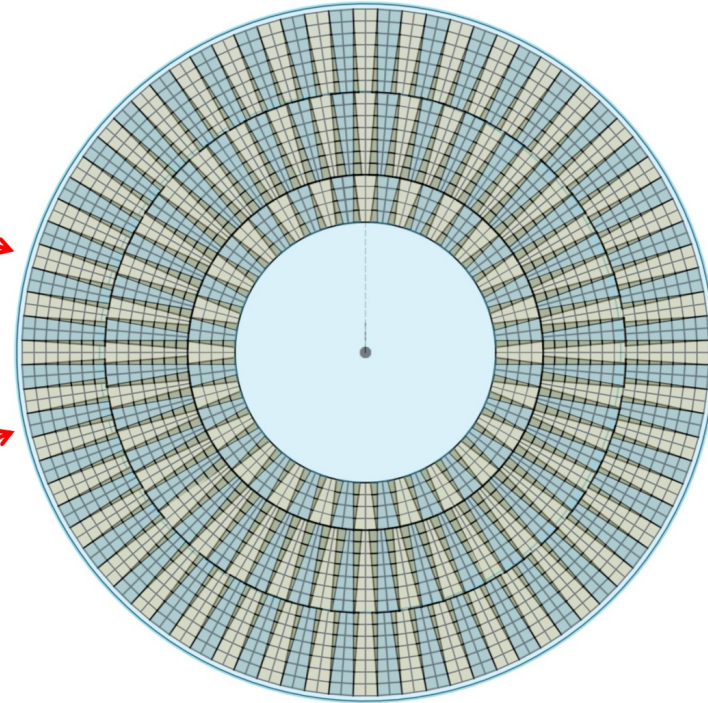

Perspective view of full endcap

The Module and Sensor Layout of a Single Face of Each ITK Endcap

Endcap	Number of module rings	Number of modules per module ring	Number of sensors per module	Total sensors
ITKE1	2	13,20	8,8	264
ITKE2	3	16,24,28	8,8,8	544
ITKE3	3	24,36,44	12,14,14	1408
ITKE4	3	24,36,44	8,14,12	1224
Total				3440



# Section 5.3.2.3: Alternative design for the ITK

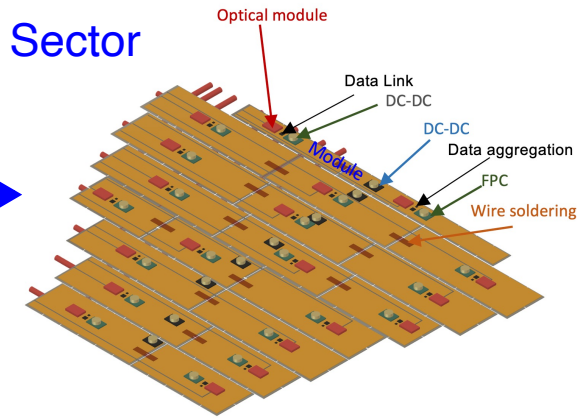
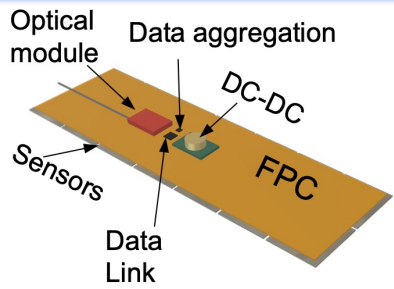
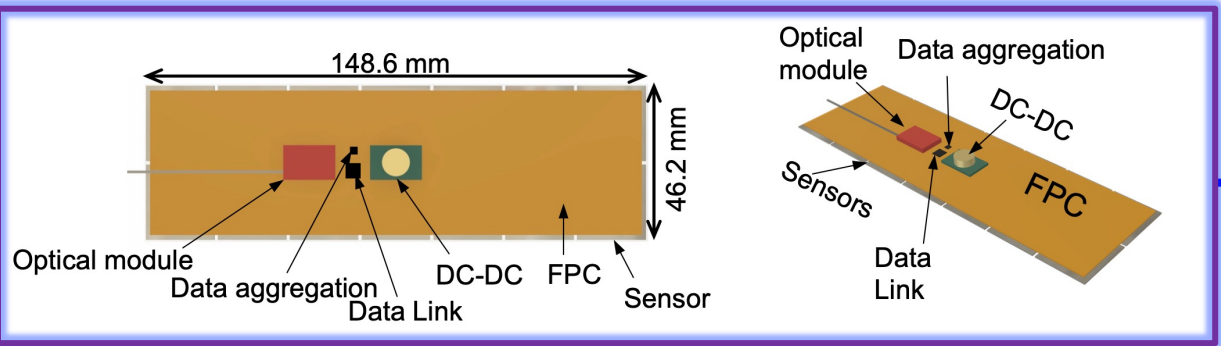

## CMOS Strip Chip/Sensor (CSC) for CEPC:

- Chip size: 21 mm × 23 mm
- Strip number per chip: 1024
- Strip pitch size: 20 μm (spatial resolution 5 μm)
- Time resolution: 3-5 ns
- Power consumption: ~80 mW/cm

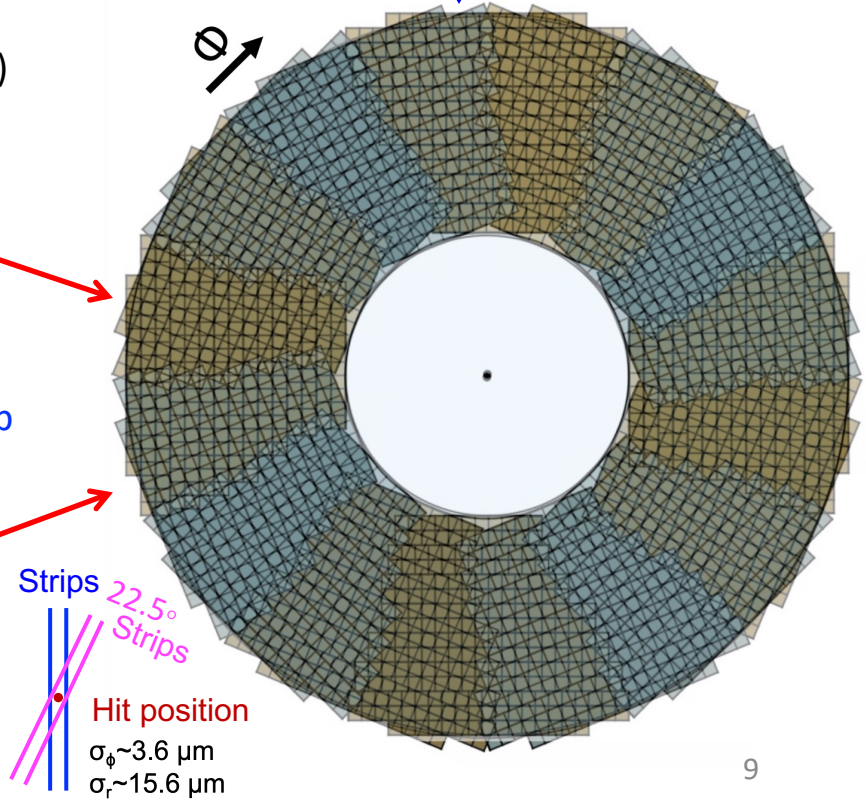
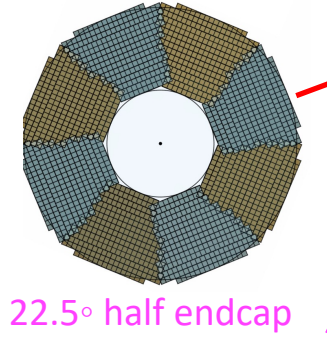
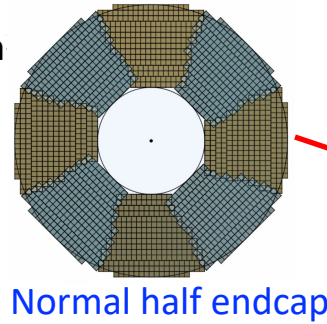
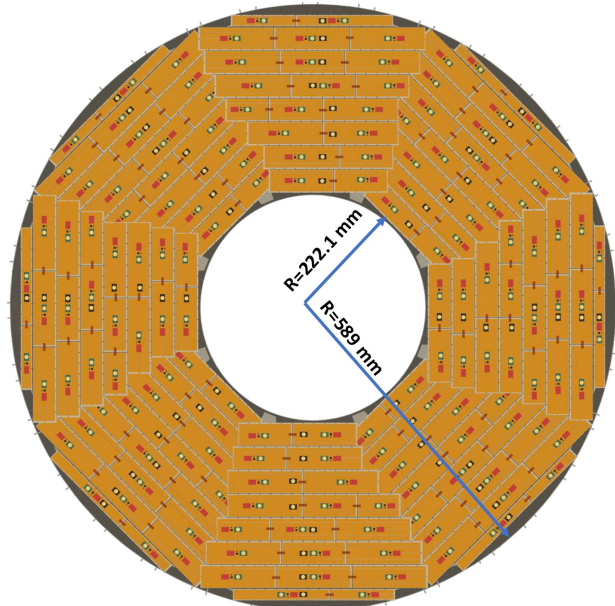

# Section 5.3.3: Readout electronics

## 5.3.3 Readout electronics

In each ITK module, 14 monolithic HV-CMOS pixel sensors are bonded to a common flexible PCB (FPC), as shown in Fig. 5.34. The FPC transmits digital signals from the sensors to the data aggregation chips and subsequently to the optical fiber. To ensure error-free data transmission, the FPC integrates two ASICs for data aggregation: the TaoTie chip and the ChiTu chip and the ChiTu chip.

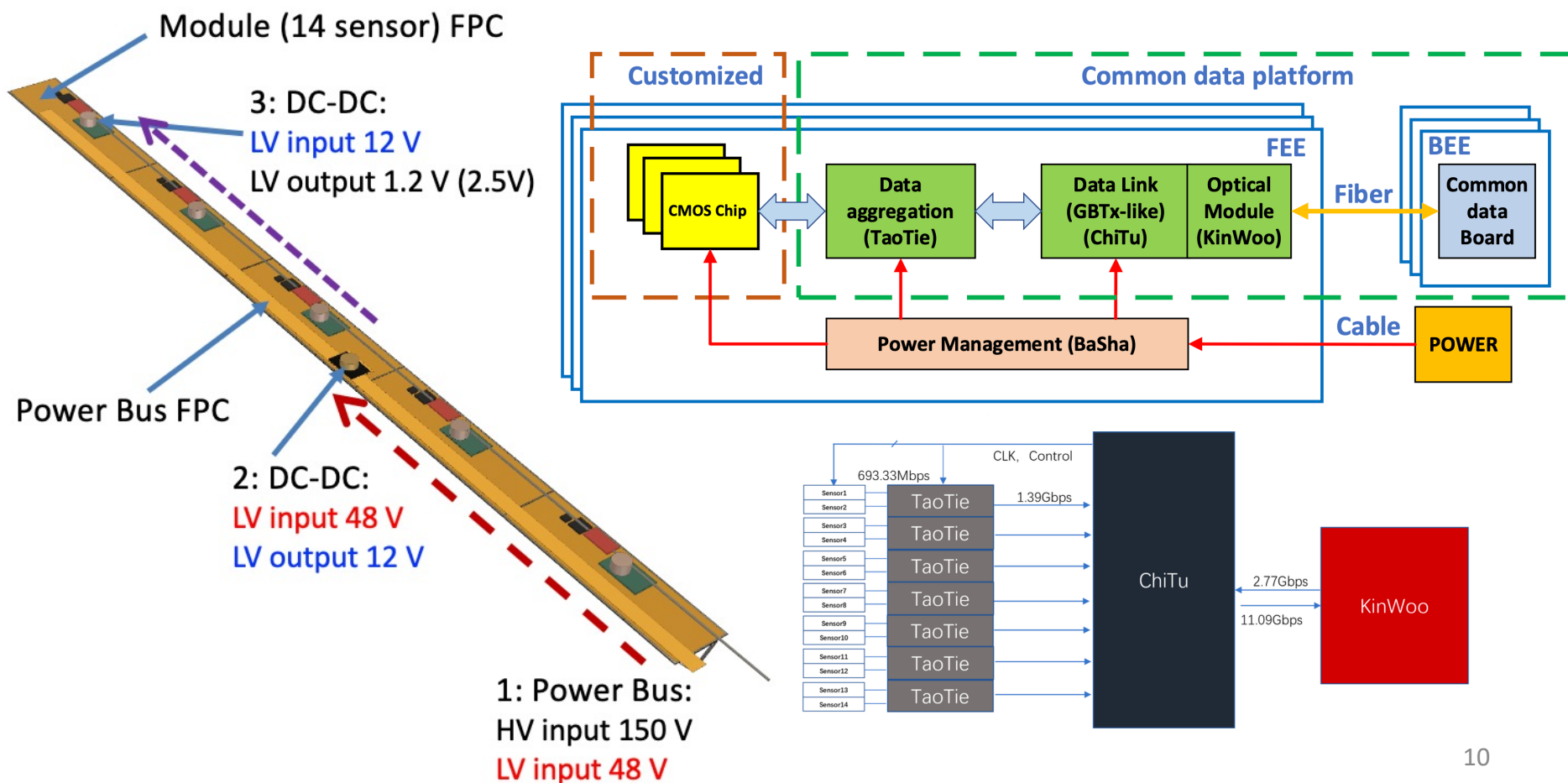



# Section 5.3.4: Mechanical and cooling design

## 5.3.4 Mechanical and cooling design

- 5.3.4.1 Barrel local support . . . . .
- 5.3.4.1.1 Materials . . . . .
- 5.3.4.1.2 Structural characterisation . . . . .
- 5.3.4.1.3 Thermal characterisation . . . . .
- 5.3.4.2 Endcap local support for HV-CMOS pixel detector
- 5.3.4.2.1 Materials . . . . .
- 5.3.4.2.2 Structural characterisation . . . . .
- 5.3.4.2.3 Thermal characterisation . . . . .
- 5.3.4.3 Endcap local support for CMOS strip detector . . . . .
- 5.3.4.3.1 Materials . . . . .
- 5.3.4.3.2 Structural characterisation . . . . .
- 5.3.4.3.3 Thermal characterisation . . . . .

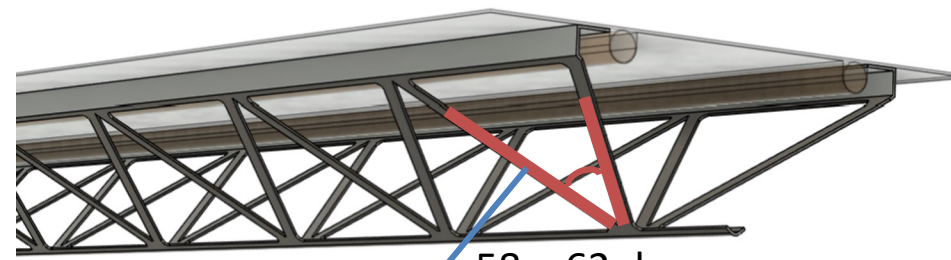

CEPC ITK Barrel stave  
58 – 62 deg

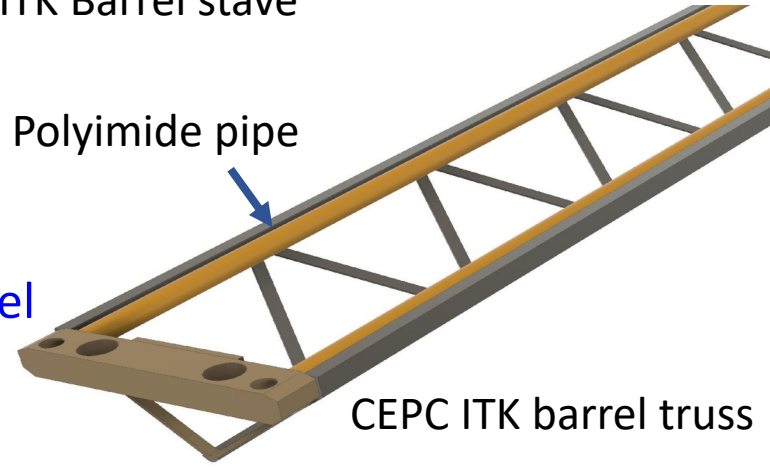

Polyimide pipe  
Barrel  
CEPC ITK barrel truss

### Endcap

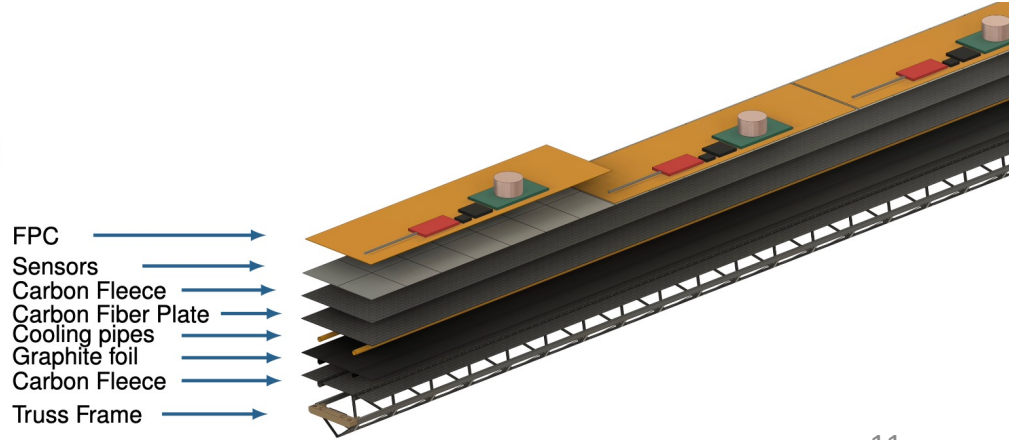
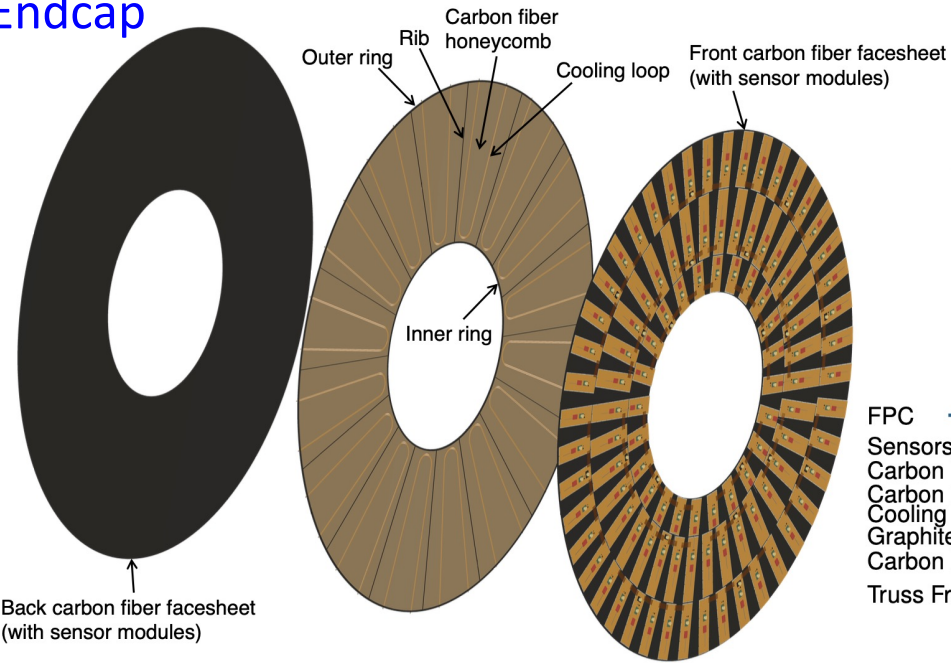

# Section 5.3.5: Prospects and plan

The CEPC team has successfully developed several fully functional Monolithic Active Pixel Sensors (MAPS), including JadePix, TaichuPix, and CPV, based on the CMOS Image Sensor (CIS) process. The HV-CMOS pixel sensor and the CMOS strip sensor, both new monolithic full-depletion sensors, are distinguished by their exceptional radiation tolerance, high spatial resolution, and particularly good timing for bunch tagging. These two sensor approaches are key detector technologies targeted for application in the CEPC ITK.

Notably, the HV-CMOS pixel sensor as the baseline for ITK, developed using the 55 nm process, has undergone two rounds of prototype tape-outs, achieving critical principle verification. Meanwhile, the CMOS strip sensor as an alternative approach, offers advantage in spatial resolution and has technological differentiation. Its first design has been completed, and fabrication is scheduled. Over the next few years of iterations, both CMOS sensors will move steadily toward fully functional, full-size sensors. In parallel, the development of module level and system level integration, including R&D on supporting electronics, mechanical structures, cooling systems, as well as detailed integration methodologies, is also in progress.

- 5.3.5 Prospects and plan . . . . .
- 5.3.5.1 Development of the CMOS pixel sensor . . . . .
- 5.3.5.2 Development of the CMOS strip sensor . . . . .
- 5.3.5.3 Module and system level development . . . . .

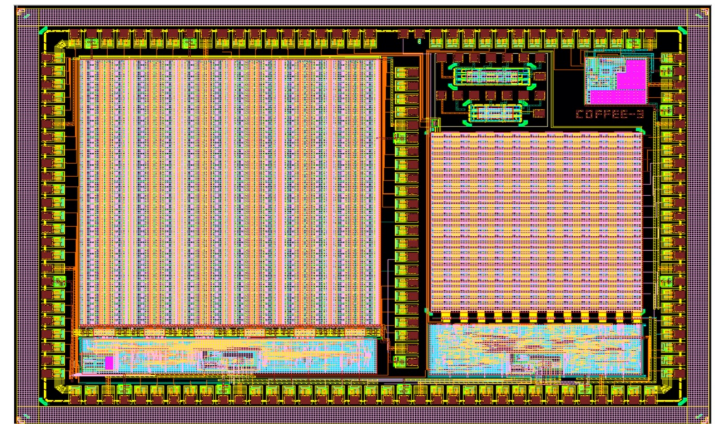

COFFEE3

这部分的内容会根据这几月COFFEE3的最新流片情况做一定的补充。

# Section 5.4: Outer Silicon Tracker (OTK)

## 5.4.1 AC-LGAD sensor and ASIC R&D

- 5.4.1.1 AC-LGAD Sensor R&D . . . . .
  - 5.4.1.1.1 AC-LGAD simulation . . . . .
  - 5.4.1.1.2 Testing setup . . . . .
  - 5.4.1.1.3 Pixelated AC-LGAD prototypes . . . . .
  - 5.4.1.1.4 Strip AC-LGAD prototype and properties . . . . .
- 5.4.1.2 AC-LGAD ASIC R&D . . . . .
  - 5.4.1.2.1 General requirements . . . . .
  - 5.4.1.2.2 ASIC architecture . . . . .
  - 5.4.1.2.3 Single-channel readout electronics . . . . .
  - 5.4.1.2.4 Data process and digital blocks . . . . .
  - 5.4.1.2.5 Prototype . . . . .
  - 5.4.1.2.6 Power distribution and grounding . . . . .
  - 5.4.1.2.7 Radiation tolerance . . . . .
  - 5.4.1.2.8 Monitoring . . . . .
  - 5.4.1.2.9 Development plan and schedule . . . . .

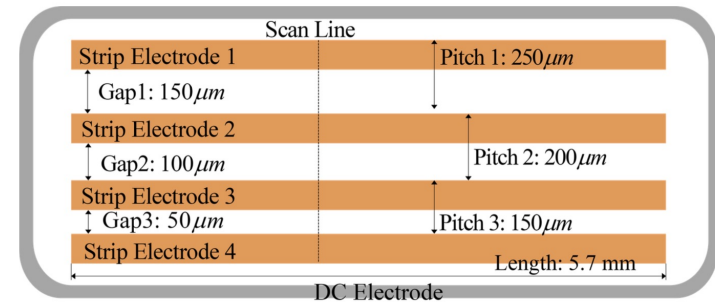
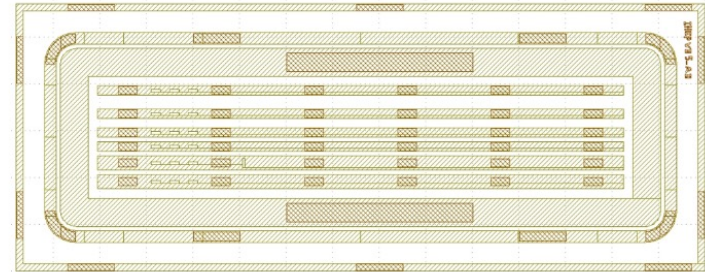

Strip AC-LGAD

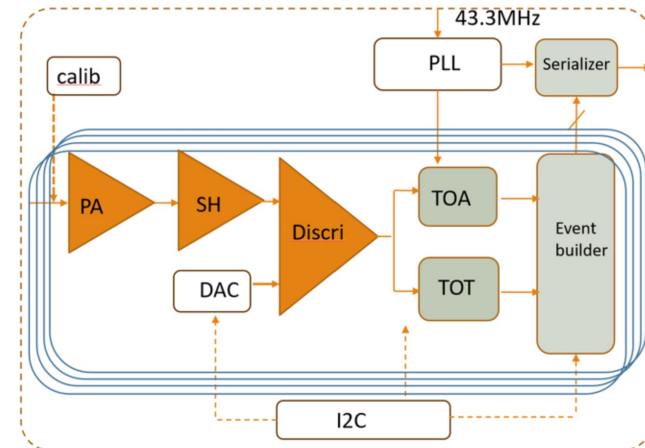

AC-LGAD ASIC

## 5.4.2 OTK design

- 5.4.2.1 OTK barrel design . . . . .
- 5.4.2.2 OTK endcap design . . . . .
- 5.4.2.3 OTK backup design . . . . .



# Section 5.4.2.1: OTK barrel design

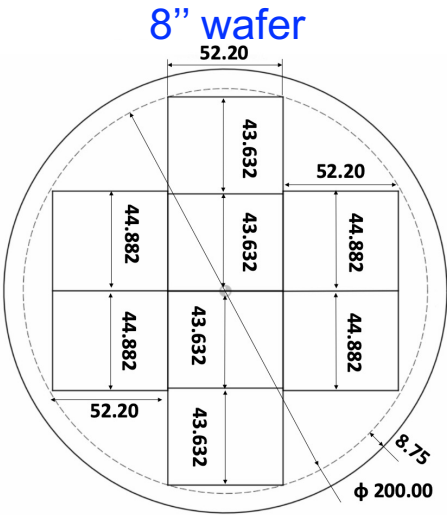

Module (2×2 sensors)

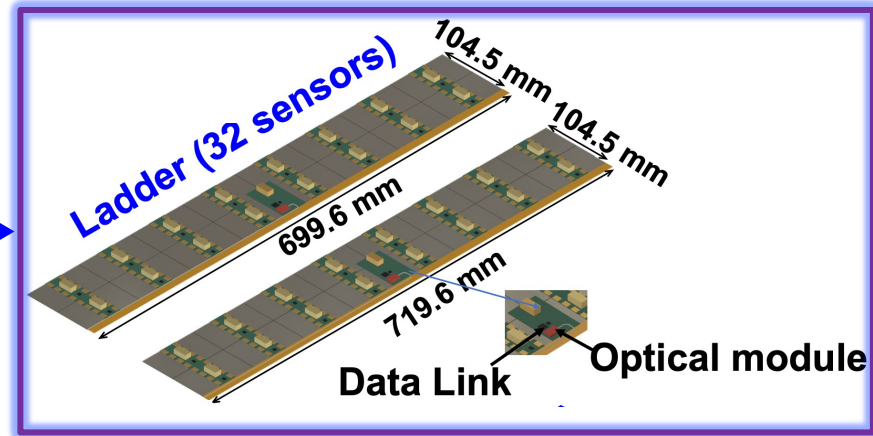
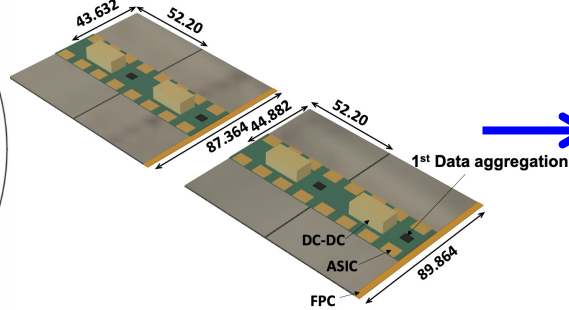

## ■ AC-LGAD strip sensor:

- Sensor size: 43.632 mm × 52.20 mm  
44.882 mm × 52.20 mm
- Strip length: 43.032 mm or 44.282 mm
- Strip number: 512 × 2
- Strip pitch: 100 μm
- Time resolution: 50 ps
- Power consumption: 300 mW/cm<sup>2</sup>

## ■ Module: 4 sensors (16 readout ASICs with 128-channels)

## ■ Ladder:

- 8 modules (32 sensors)
- Length: 699.6 mm or 719.6 mm

## ■ Stave: 8 ladders (4 short+4 long)

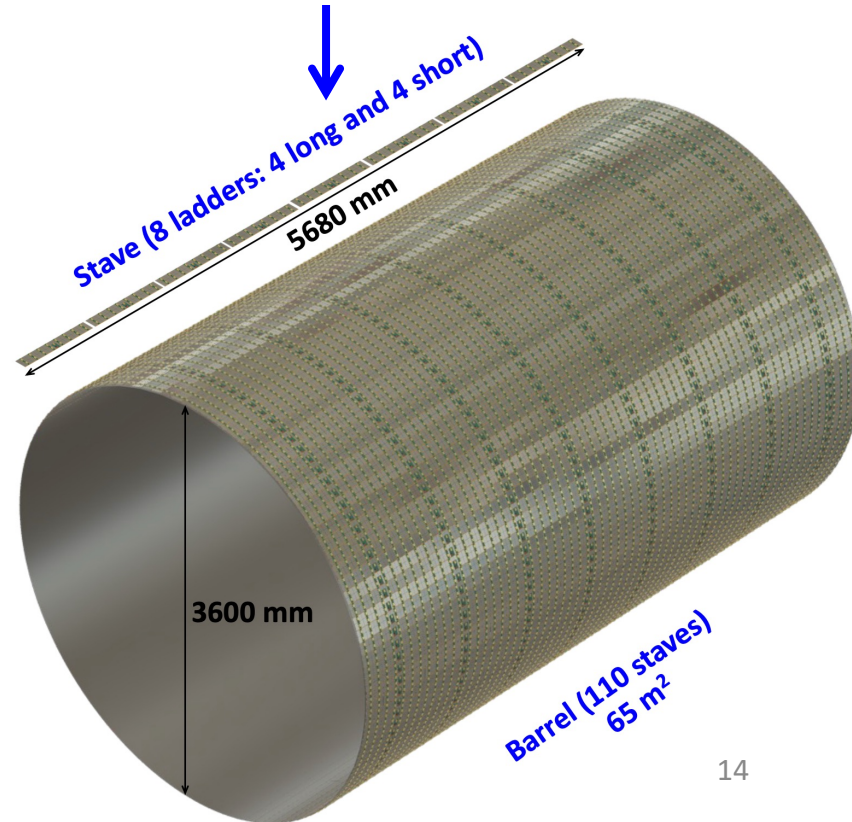

# Section 5.4.2.2: OTK endcap design

Endcap (16 sectors, 10 m<sup>2</sup>)

1/16 Sector

Sensor: 8'' wafer (group C sensors)

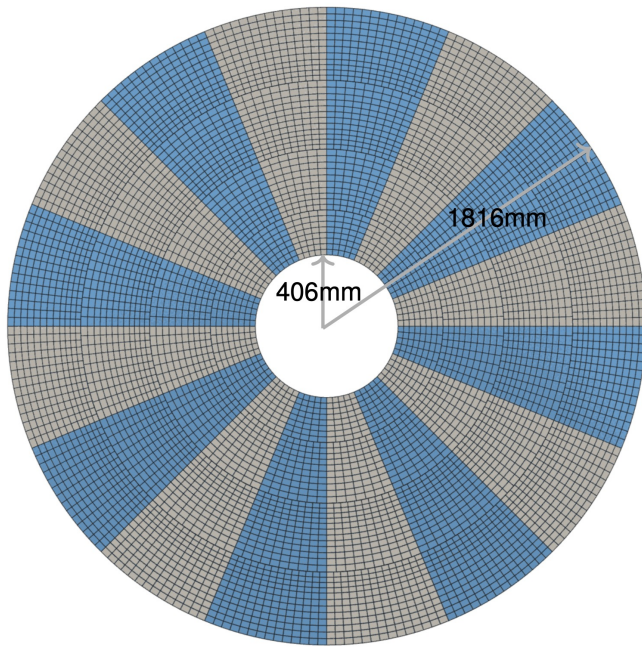

Group D:  
1400mm-1816mm

Group C:  
1008mm-1400mm

Group B:  
662mm-1008mm

Group A:  
406mm-662mm

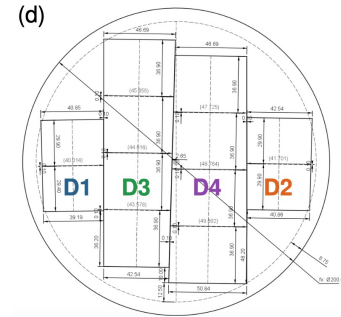
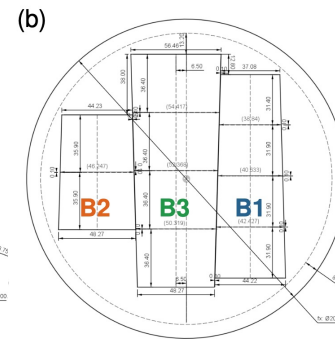
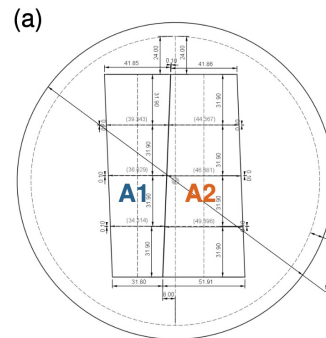
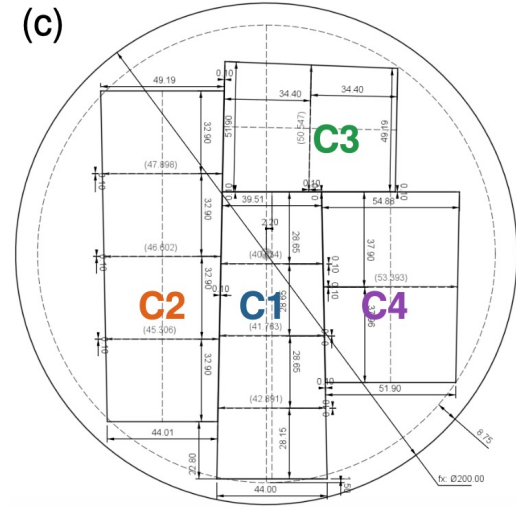
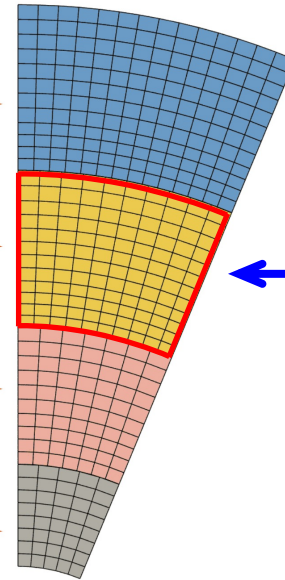

- OTK endcap consists of 42 rings, arranged into 4 groups.
- Each group contains 2-4 subgroups of trapezoid sensors, dicing from one 8'' silicon wafer.
- Each group of sensors is aligned to a 1/16 sector.
  - Strip pitch : 80.59-113.026  $\mu\text{m}$
  - Strip length : 28.05-36.3 mm

8'' wafer (group A, B, D sensors)

Maximize the use of silicon wafers and facilitate detector assembly.



# Section 5.4.2.3: OTK backup design

Module (2 × 5 Sensors)

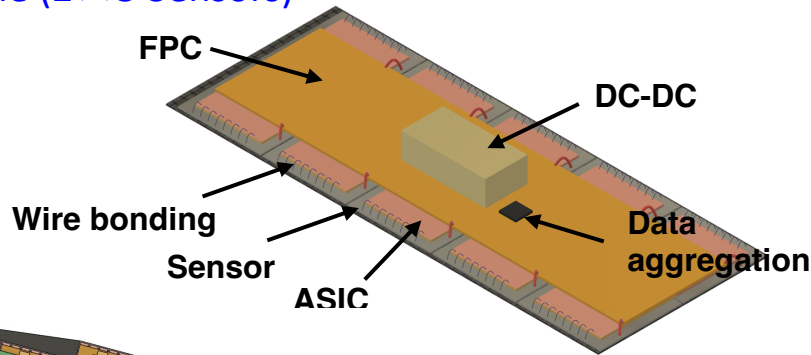

Ladder (17 or 18 modules)

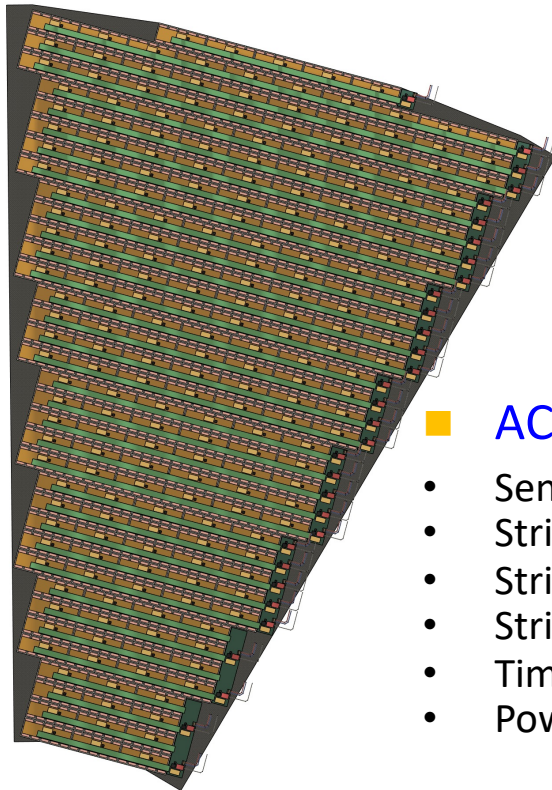
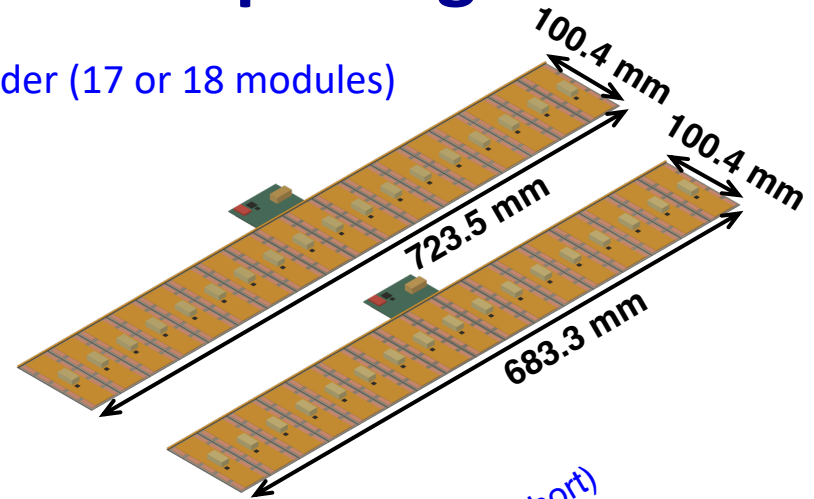

## ■ AC-LGAD strip sensor:

- Sensor size: 20 mm × 20 mm
- Strip length: 19.4 mm
- Strip number: 128
- Strip pitch: 151.56 μm
- Time resolution: 50 ps
- Power consumption: 300 mW/cm<sup>2</sup>

1/12 Endcap Sector

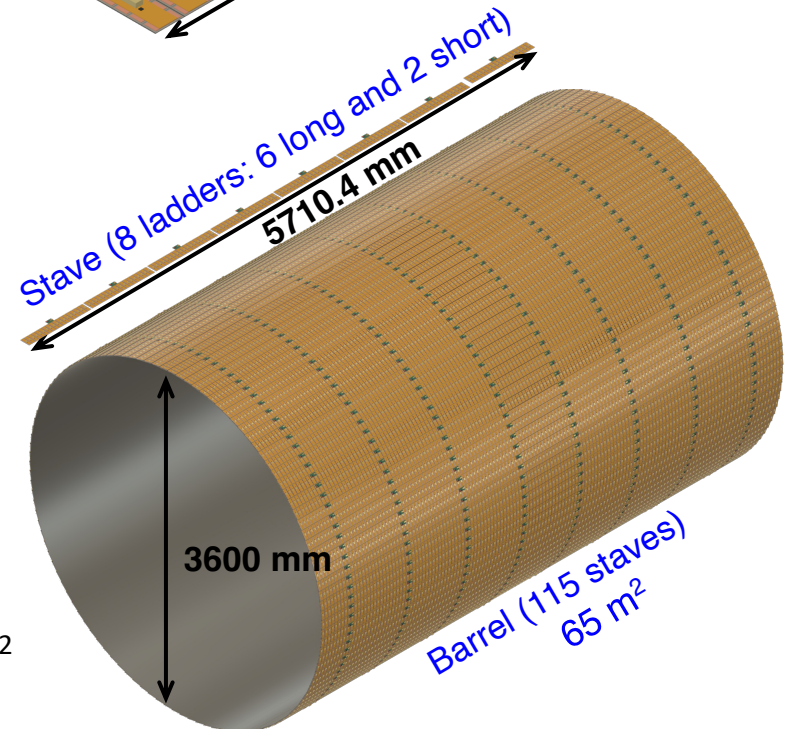



# Section 5.4.3: Readout electronics

- 5.4.3 Readout electronics . . . . .
- 5.4.3.1 Front-end board . . . . .
- 5.4.3.2 Concentrator Card and power distribution . . . . .
- 5.4.3.3 Slow control and monitoring . . . . .
- 5.4.3.4 Clock distribution . . . . .

Group C sensors

1/16 Sector

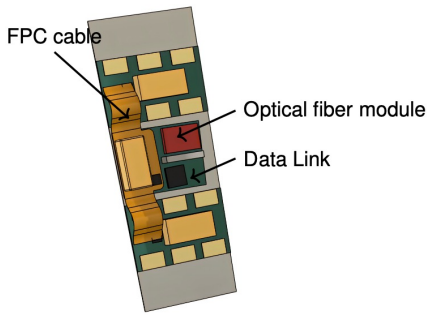
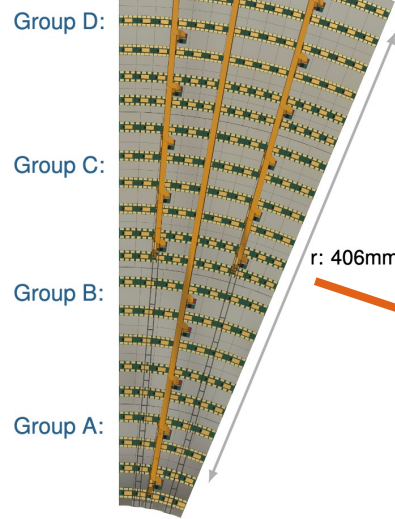
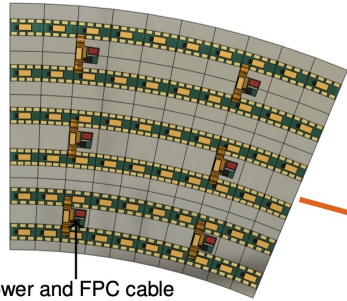

Endcap (16 sectors)

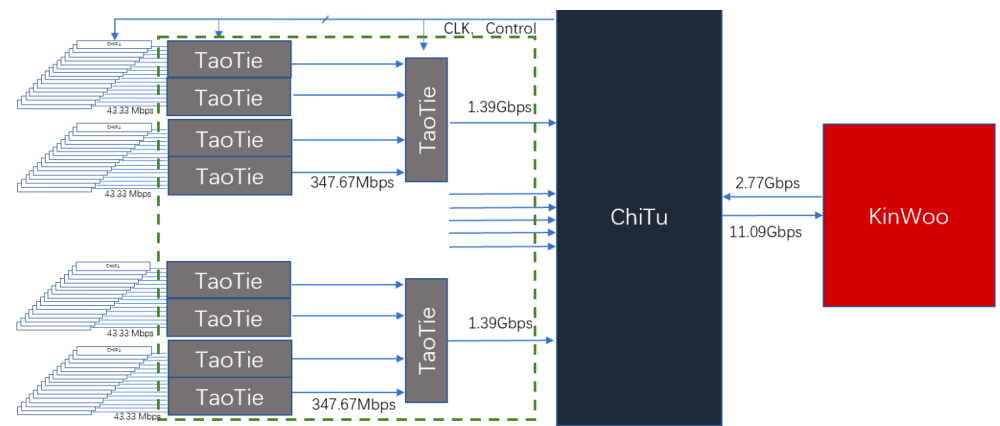
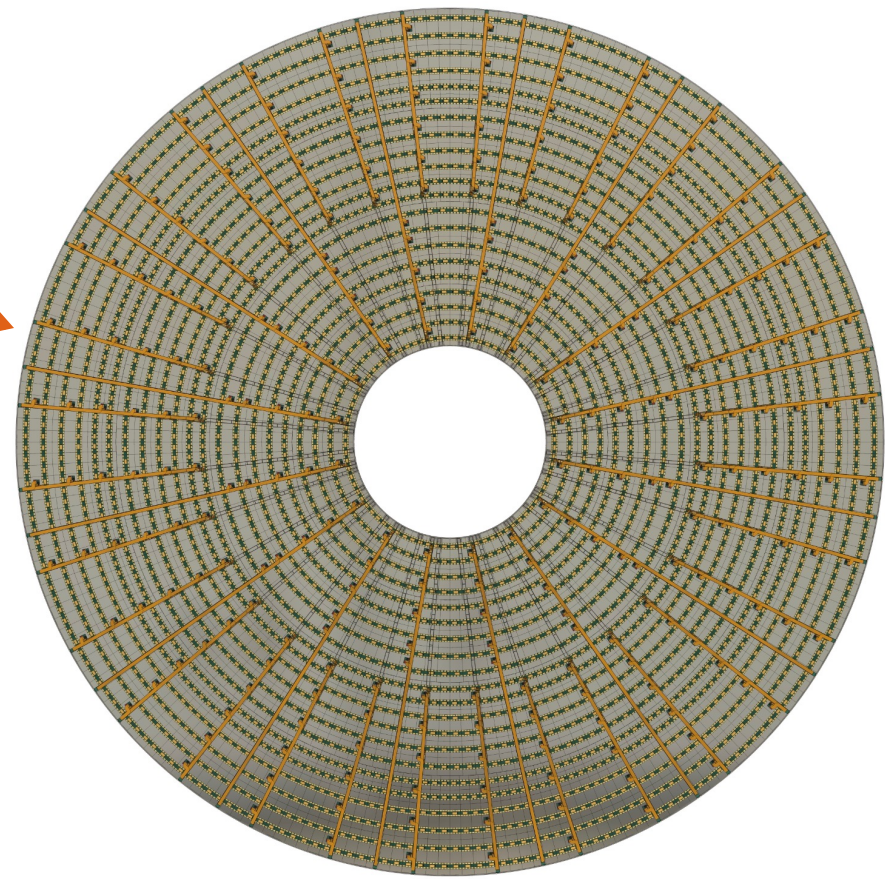

# Section 5.4.4: Mechanical and Cooling Design

## 5.4.4 Mechanical and cooling design

- 5.4.4.1 Barrel support . . . . .
- 5.4.4.1.1 Materials . . . . .
- 5.4.4.1.2 Structural characterisation . . . . .
- 5.4.4.1.3 Thermal characterisation . . . . .
- 5.4.4.2 Endcap support . . . . .
- 5.4.4.2.1 Materials . . . . .
- 5.4.4.2.2 Structural characterisation . . . . .
- 5.4.4.2.3 Thermal characterisation . . . . .

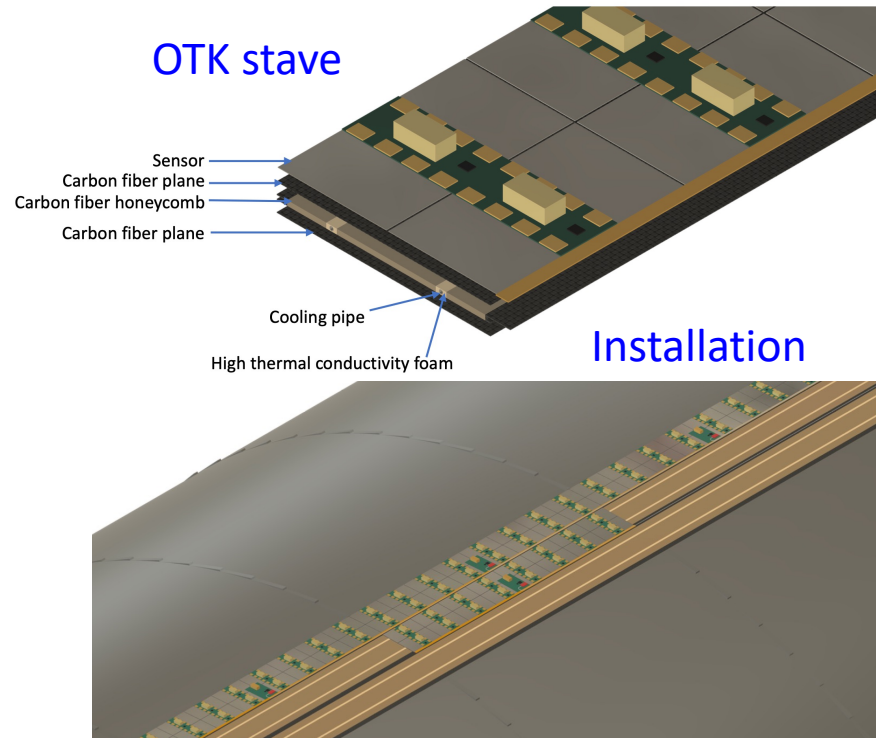

## OTK endcap 1/16 sector

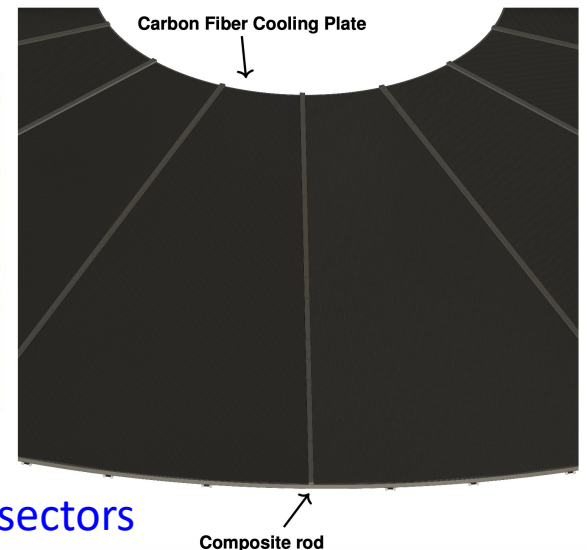
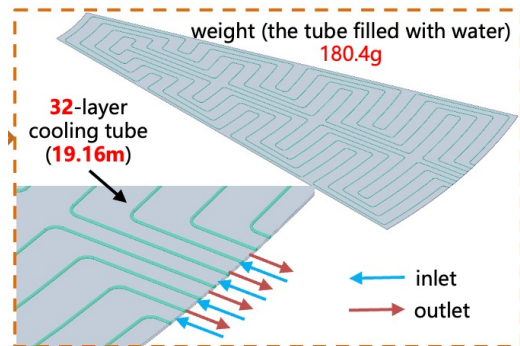
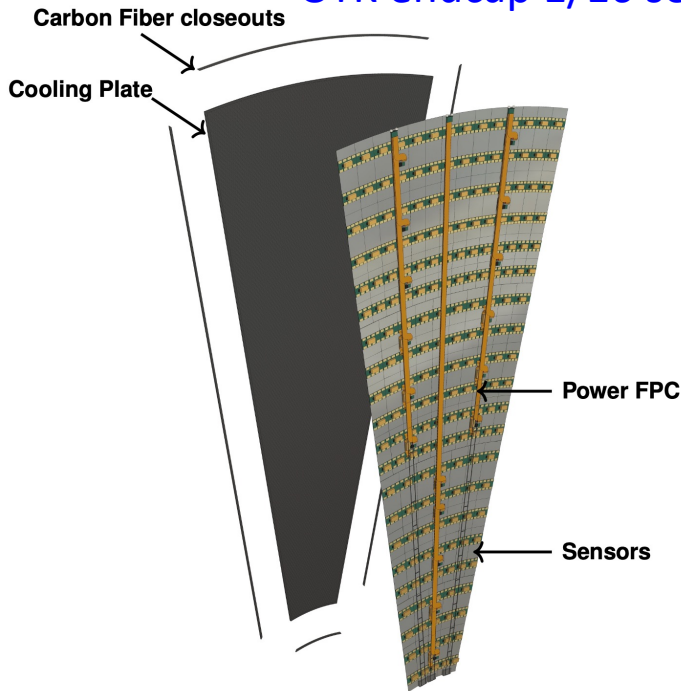

## Mounting 1/16 sectors



# Section 5.4.5: Prospects and plan

- 5.4.5 Prospects and plan . . . . .
- 5.4.5.1 Development of AC-LGAD strip sensor for CEPC . . . . .
- 5.4.5.2 Development of AC-LGAD readout ASIC . . . . .
- 5.4.5.3 Development of mechanical and cooling system . . . . .
- 5.4.5.4 Summary . . . . .

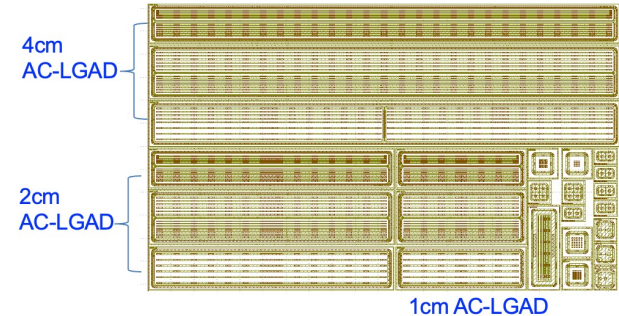

## 5.4.5.4 Summary

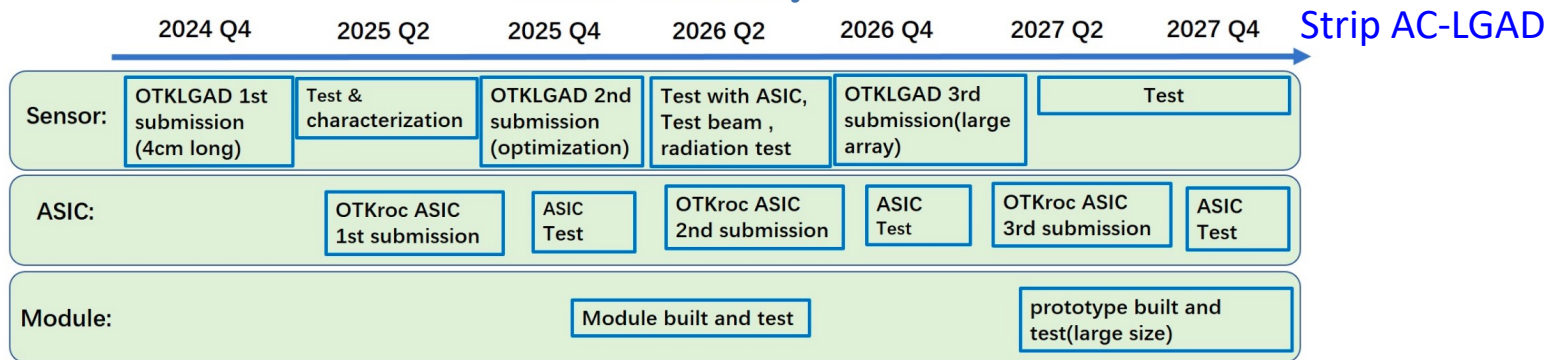

**Figure 5.106:** Timeline for OTK, including sensor, ASIC, mechanics and so on

All the R&D mentioned above is part of a 3-year plan, as detailed in Fig. 5.106. Considering the project timeline of more than 5 years from construction, the CEPC project is flexible enough to adjust its technical approach and has sufficient backup plans for the engineering phase. For example, if the performance of the AC-LGAD strip sensor degrades significantly for large-dimension strip sensor, we may consider using conventional large-dimension sensor, with or without an external time-of-flight detector, or opt for bump bonding or monolithic AC-LGAD technology if it becomes mature.

For the OTK system, including sensor, readout ASIC, and mechanical and cooling components, we are open to both domestic collaborations with research units and industry as well as international partnerships. In light of all these factors, we are confident in delivering a high performance OTK system that meets the physics requirements in a timely manner.

LGAD strip的流片会在本月提交。这部分的内容会根据最新流片情况做一定的补充。

# Section 5.5: Background (Hit rate) Estimation

## 5.5 Beam background estimation

- 5.5.1 Beam background simulation . . . . .
- 5.5.1.1 Pair production background . . . . .
- 5.5.1.2 Single beam background . . . . .
  - 5.5.1.2.1 Beam Thermal Photon Scattering (BTH) . . . . .
  - 5.5.1.2.2 Beam Gas Coulomb Scattering (BGC) and Beam Gas Bremsstrahlung Scattering (BGB) . . . . .
  - 5.5.1.2.3 Touschek Scattering (TSC) . . . . .
- 5.5.2 Hit rate estimation for beam background . . . . .
- 5.5.3 ITK tolerable hit rate . . . . .
- 5.5.4 OTK tolerable hit rate . . . . .

	Estimated Silicon Tracker Hit Rates [ $10^3$ Hz/cm <sup>2</sup> ]					
	Low Lumi Z		Higgs		High Lumi Z	
	Average	Max	Average	Max	Average	Max
ITKB1	3.11	4.70	0.60	0.91	24.16	34.76
ITKB2	1.85	4.21	0.44	1.11	13.04	21.15
ITKB3	0.95	1.94	0.27	0.50	5.98	10.17
OTKB	0.62	0.92	0.23	0.35	3.30	4.82
ITKE1	11.20	50.96	2.72	12.08	98.64	487.01
ITKE2	7.01	41.59	1.89	9.65	50.30	326.48
ITKE3	3.13	28.93	0.92	7.53	17.57	130.50
ITKE4	2.23	10.03	0.69	2.52	13.03	59.09
OTKE	0.98	4.00	0.37	1.45	5.45	23.89

### 5.5.4 OTK tolerable hit rate

For the AC-LGAD strip sensor used in the OTK, each fired strip generates 48 bits of data, with an average of  $\sim 2$  strips firing per hit. Data from 6 or 8 sensor readout ASICs (6 ASICs are used only in specific parts of the OTK endcap) is aggregated by a primary data aggregation chip. In the OTK barrel, 16 primary data aggregation chips (e-links) are connected to a common data link chip (ChiTu) on the second aggregation board, with each primary data aggregation chip connecting via a 346.67 Mbit/s e-link. In the OTK endcap, 10 to 14 primary data aggregation chips (e-links) are connected to a common data link chip on the second aggregation board, with each primary data aggregation chip connecting via a 693.33 Mbit/s or 346.67 Mbit/s e-link.

The supported data rate per sensor readout ASIC is up to 43.33 Mbit/s for the barrel and up to 86.67 Mbit/s for the endcap, corresponding to a maximum hit rate of  $8.0 \times 10^4$  Hz/cm<sup>2</sup> for the barrel (detector active area  $\sim 1.28$  cm  $\times$  4.4 cm per ASIC) and  $2.1 \times 10^5$  Hz/cm<sup>2</sup> for the endcap (detector active area  $\sim 1.28$  cm  $\times$  3.3 cm per ASIC). This detector's tolerable hit rate is  $\sim 17$  times larger than the estimated maximum background hit rate for the OTK barrel (OTKB,  $4.82 \times 10^3$  Hz/cm<sup>2</sup>) and  $\sim 9$  times larger than that for the OTK endcap at High Lumi Z (OTKE,  $23.89 \times 10^3$  Hz/cm<sup>2</sup>), as summarized in Table 5.19.

# Section 5.6 Performance

## 5.6 Performance

- 5.6.1 The performance of the barrel region . . . . .
  - 5.6.1.1 Momentum resolution . . . . .
  - 5.6.1.2 Roles of gaseous and silicon trackers . . . . .
  - 5.6.1.3 Particle identification performance . . . . .
- 5.6.2 The performance of the forward region (endcap) . . . . .
  - 5.6.2.1 Momentum resolution performance . . . . .
  - 5.6.2.2 Particle identification performance . . . . .

Momentum resolution in the barrel region:

$$\left(\frac{\sigma_{p_t}}{p_t}\right)_{\text{Si}} = ap_t \oplus \frac{b}{\beta\sqrt{\sin\theta}}$$

$$\left(\frac{\sigma_{p_t}}{p_t}\right)_{\text{TPC}} = as_1 p_t \oplus \frac{bs_2}{\beta\sqrt{\sin\theta}}$$

$$\left(\frac{\sigma_{p_t}}{p_t}\right)_{\text{Combined}} = \frac{1}{\sqrt{\left(\frac{\sigma_{p_t}}{p_t}\right)_{\text{Si}}^{-2} + \left(\frac{\sigma_{p_t}}{p_t}\right)_{\text{TPC}}^{-2}}}$$

where  $a = 1.5 \times 10^{-5}$ ,  $b = 1.4 \times 10^{-3}$ ,  
 $s_1 \approx 6$ , and  $s_2 \approx 0.8$ .

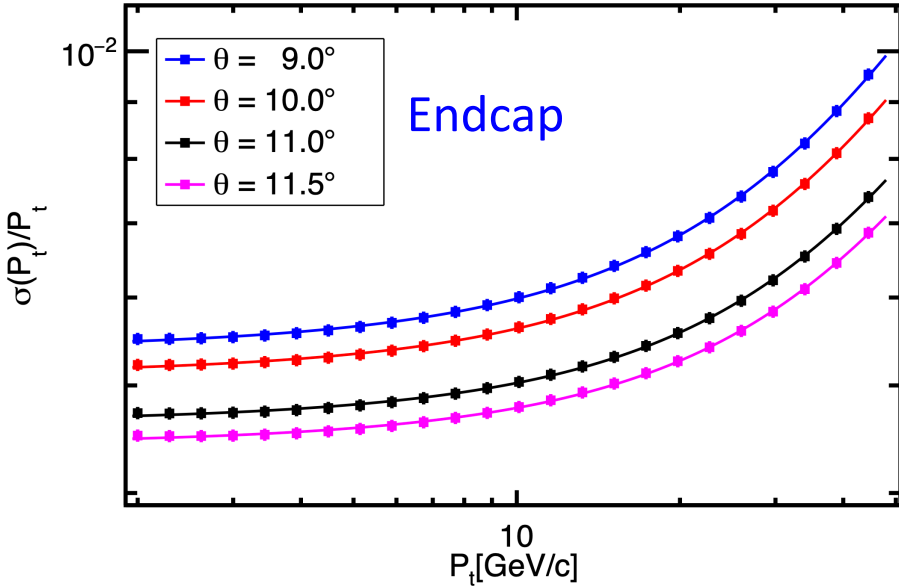

Momentum resolution in the endcap region:

$$\frac{\sigma_{p_t}}{p_t} = \frac{a'p_t}{(\tan\theta)^2} \oplus \frac{b'}{\beta\tan\theta\sqrt{\cos\theta}} \oplus \frac{c'\sqrt{p_t}}{\sqrt{\beta}(\tan\theta)^{\frac{3}{2}}(\cos\theta)^{\frac{1}{4}}}$$

where  $a' \approx 0.4 \times 10^{-5}$ ,  $b' \approx 0.9 \times 10^{-3}$ , and  $c' = 4.5 \times 10^{-5}$ .

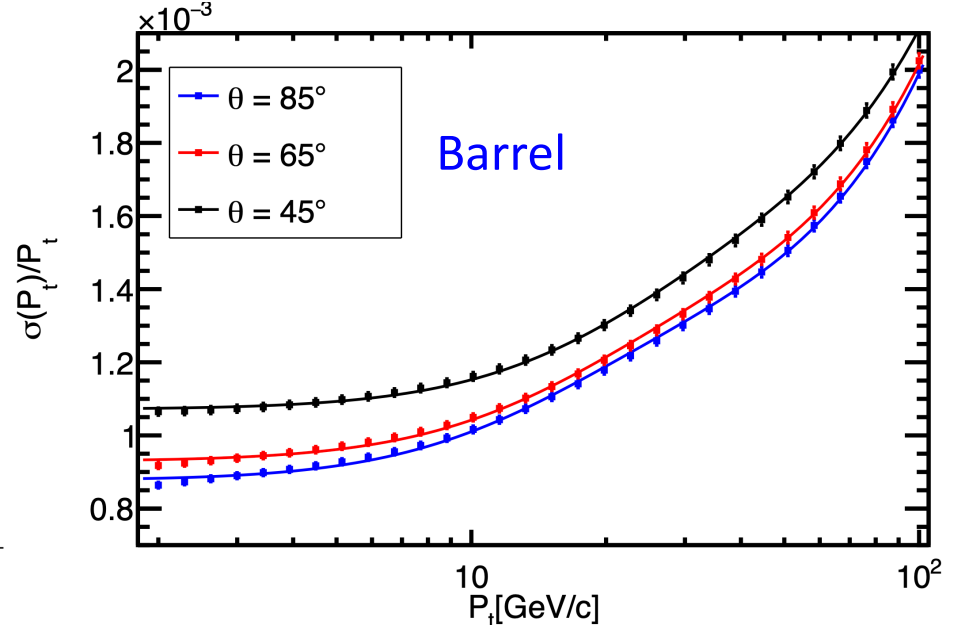

# Silicon Tracker Ref-TDR的下一步工作

- 进一步完成Silicon Tracker章节的内容填充、完善（包括Alignment章节撰写）。
- 完成对references和figure captions的系统性整理。

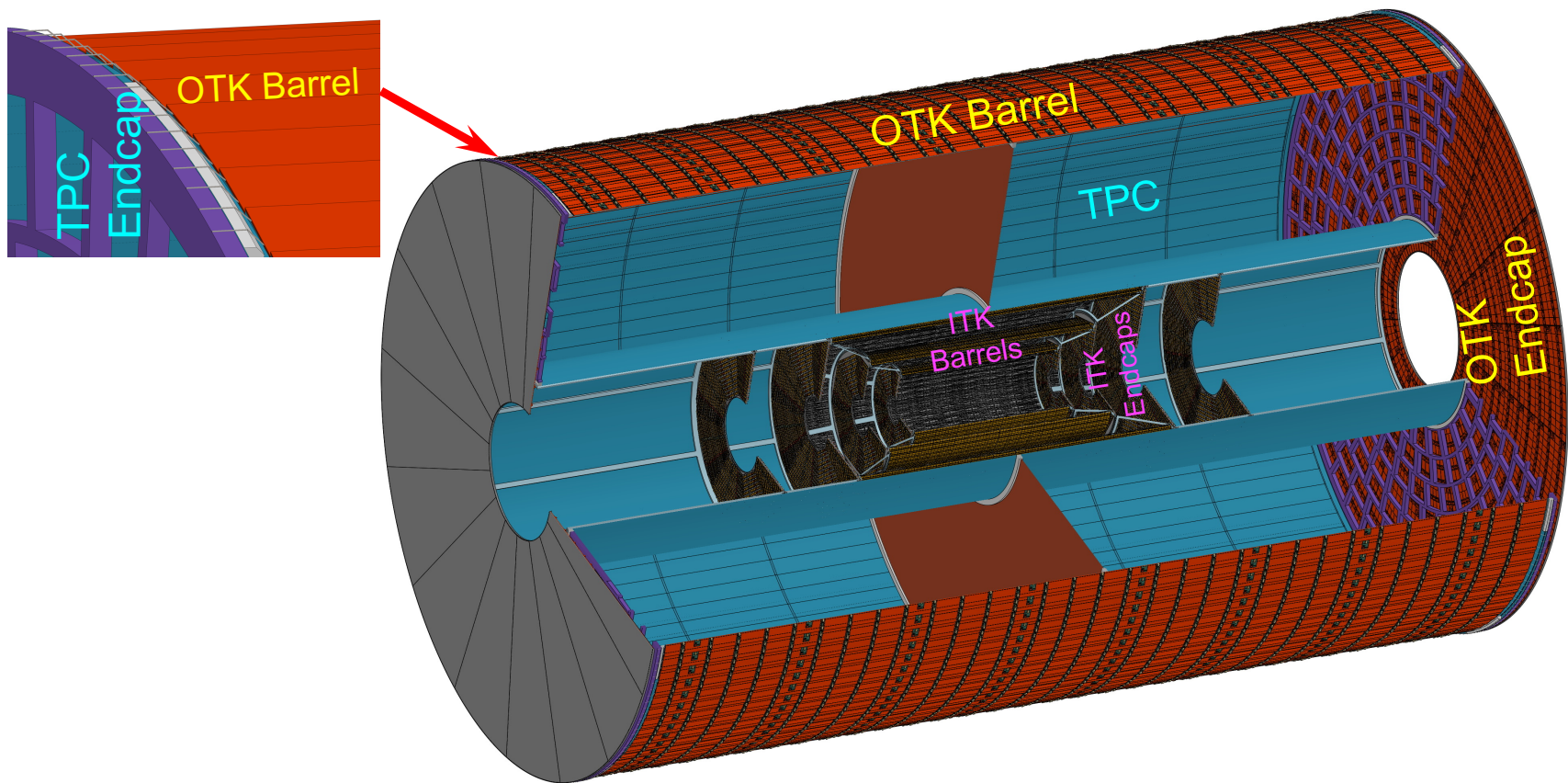

更新的内容会近期上传，不足的地方，请大家批评指正！







# Mechanical and Cooling Design for the OTK Endcap

OTK endcap 1/16 sector

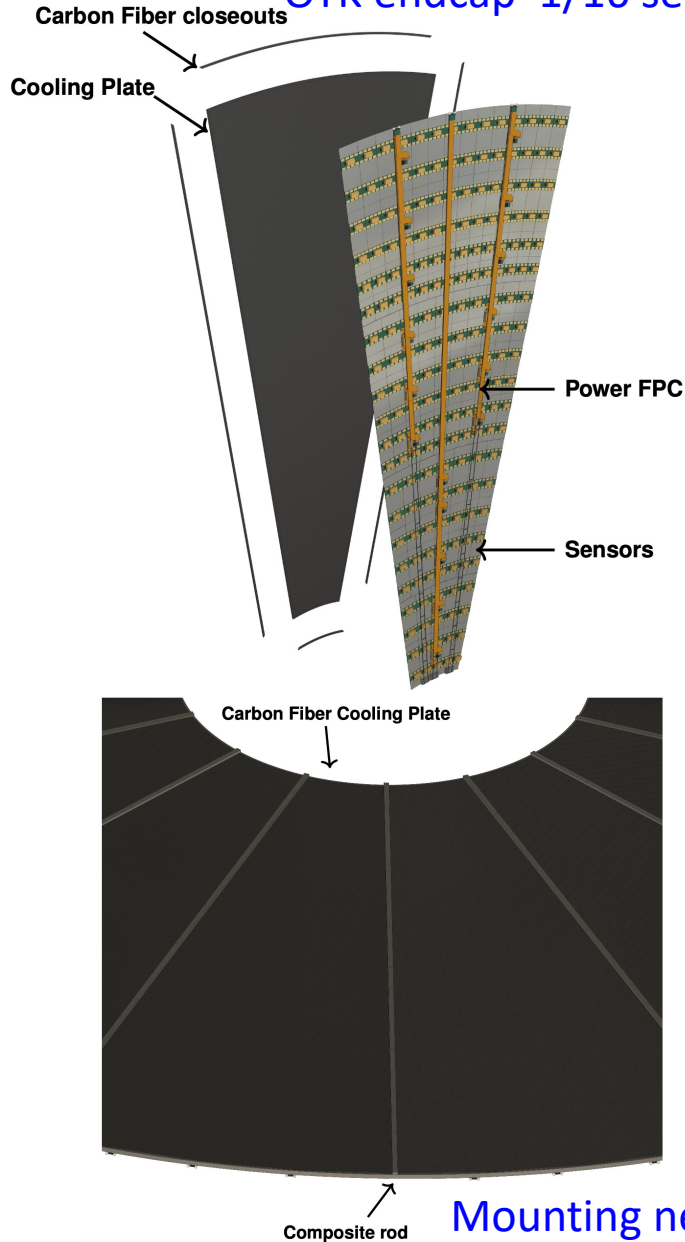

OTK Endcap

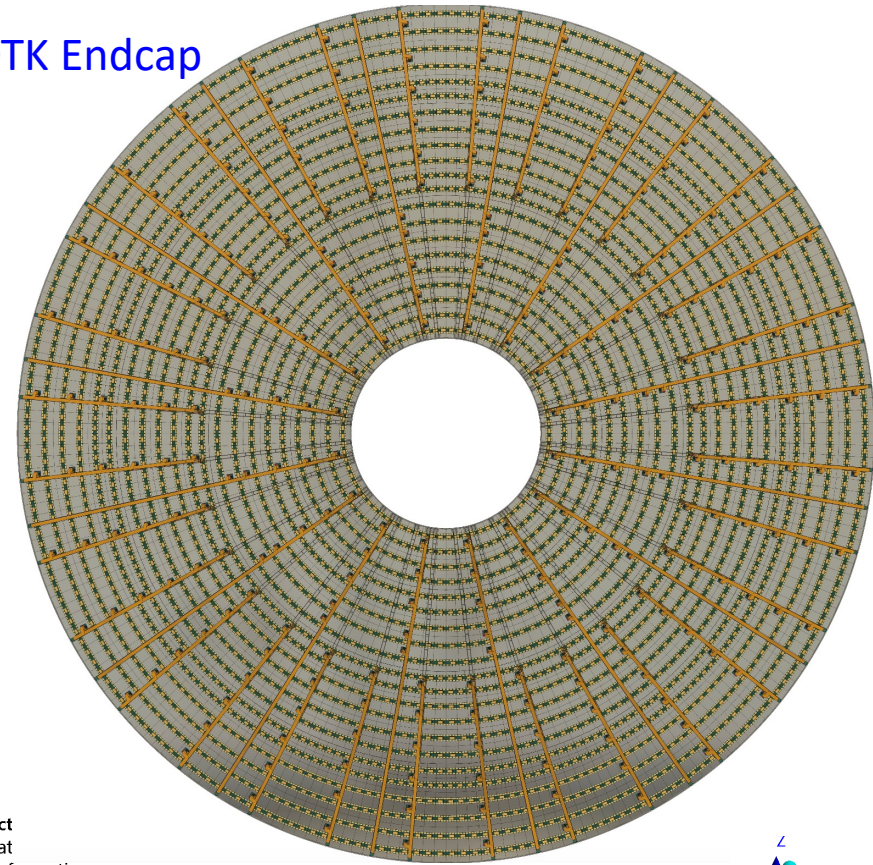

D: Static Struct  
Total Deformat  
Type: Total Deformation  
Unit: mm  
Time: 1

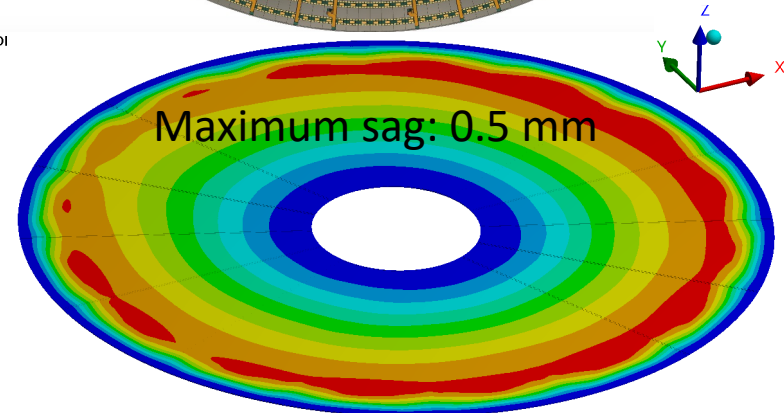
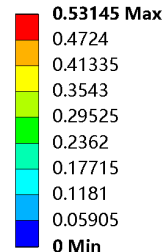

# Cooling Loop Design for the OTK Endcap

A few months ago, Quan Ji, Gang Li, and I visited Zhengzhou University of Light Industry, to explore ways to strengthen CEPC's R&D capabilities in mechanical and thermal systems.

The School of Energy and Power Engineering at Zhengzhou University of Light Industry has extensive experience and a strong focus on thermal system development, including CO<sub>2</sub> cooling. During our visit, we were highly impressed by their expertise in both thermal and mechanical engineering.

On Jan 10, the Dean of the School of Energy and Power Engineering, Professor Xuehong Wu, and his team, visited IHEP in return. They are now actively contributing to the design and analysis of the CEPC thermal system.

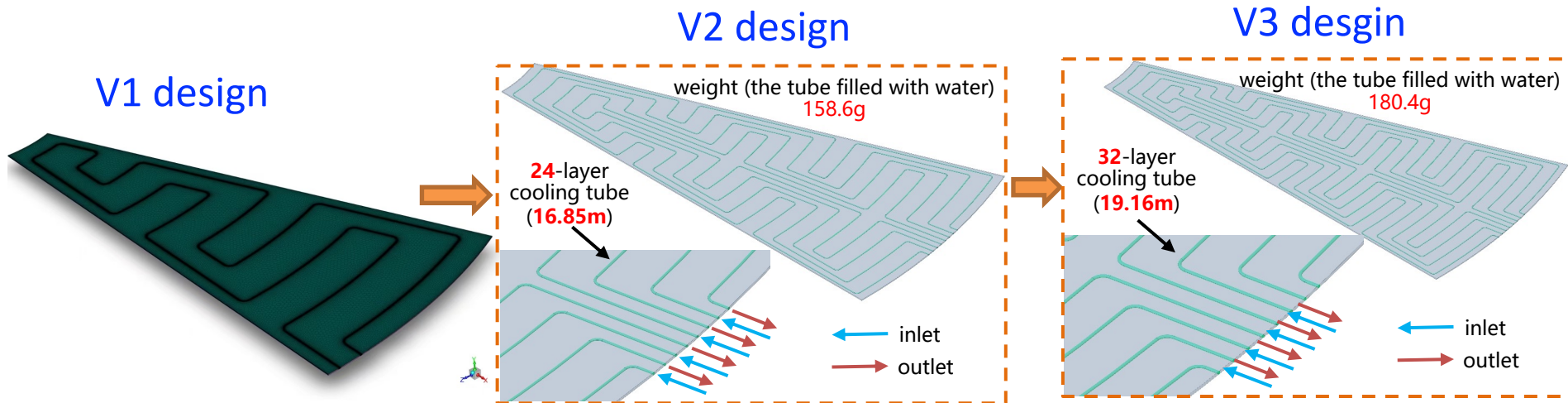

Cooling loops design and thermal analysis for the OTK endcap performed by Zhengzhou University of Light Industry (郑州轻工业大学).



# OTK Endcap Thermal Mesh Generation

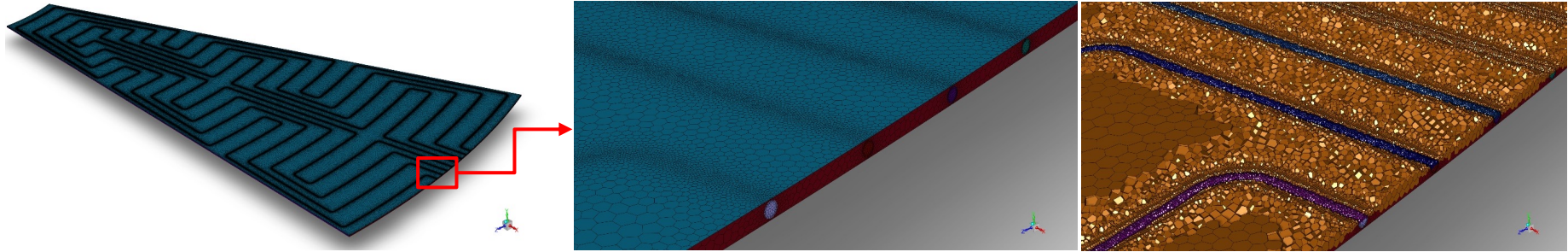

**24-layer cooling tube(16.85m, cell count 9356670, Orthogonal Quality $\geq$ 0.5)**

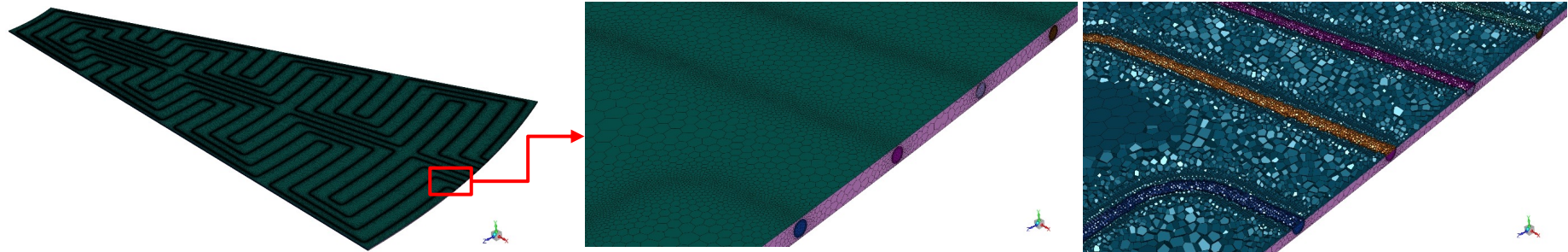

**32-layer cooling tube(19.16m, cell count 10645946, Orthogonal Quality $\geq$ 0.5)**

- ✓ The **mesh generation** is performed for **two different cooling tube arrangements**, and numerical solutions are obtained using **the finite volume method**.
- ✓ The **cooling performance** of both arrangements is **analyzed** and compared.

- Cooling tube diameter: 2.6 mm
- Water inlet velocity: 2.5m/s

Continuous optimization is ongoing!

Xuedong Wu, Yong Liu, ...  
(郑州轻工业大学)

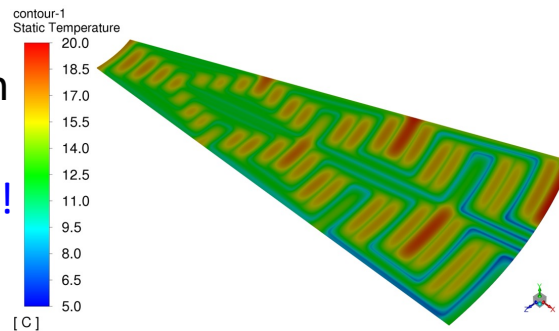

**24-layer cooling tube**

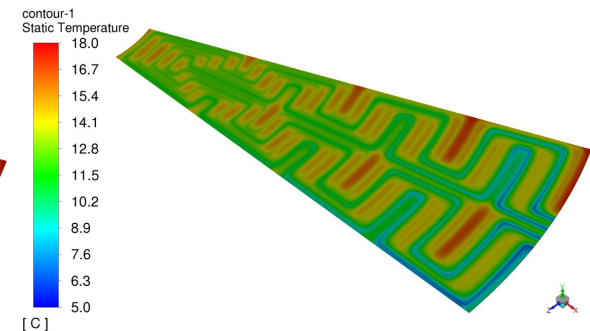

**32-layer cooling tube** 27

# Sensor and ASIC R&D Plan

## ➤ HV-CMOS Pixels (COFFEE3):

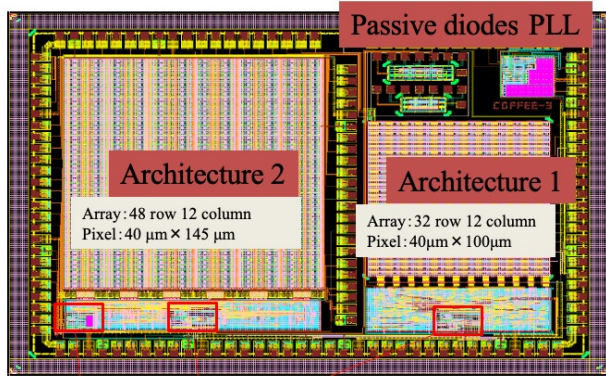

DLL LVDS driver/receiver up to 1.28Gb/s

Submitted in 2025.1 and expected received in 2025.5

## ➤ CMOS Strips (CSC1):

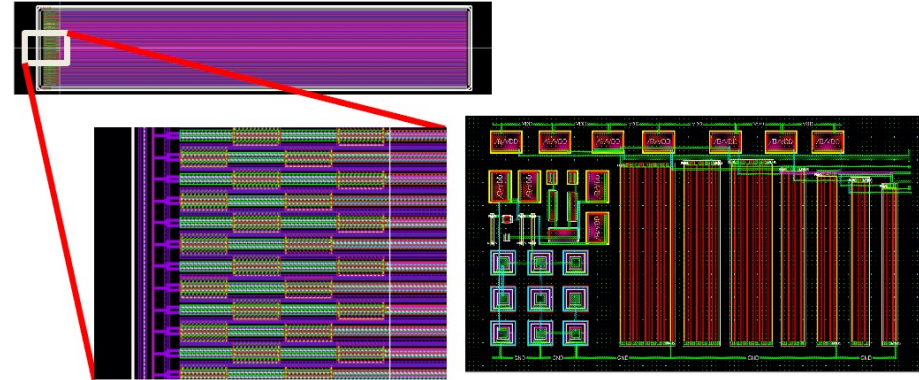

Scheduled for submission on March 5, 2025

## ➤ AC-LGAD Strips

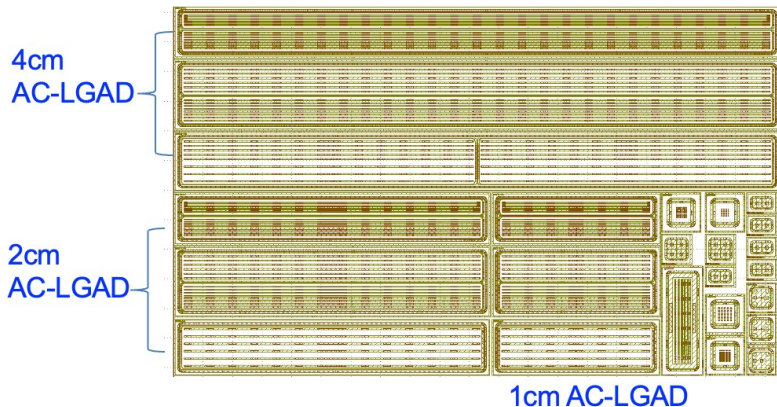

Scheduled for submission in Feb 2025

## ➤ Pre-prototype for AC-LGAD ASIC (JuLoong, 烛龙)

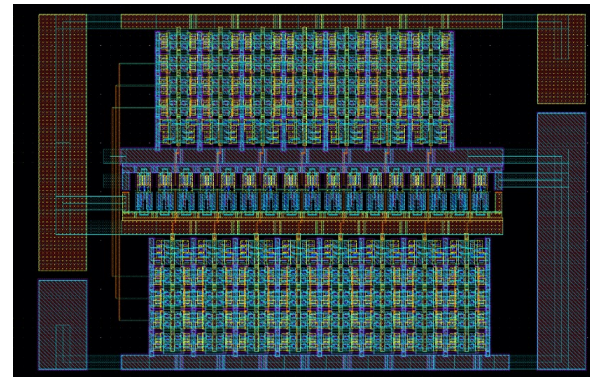

Scheduled for submission in April 2025



# OTK Backup Design

Module (10 Sensors)

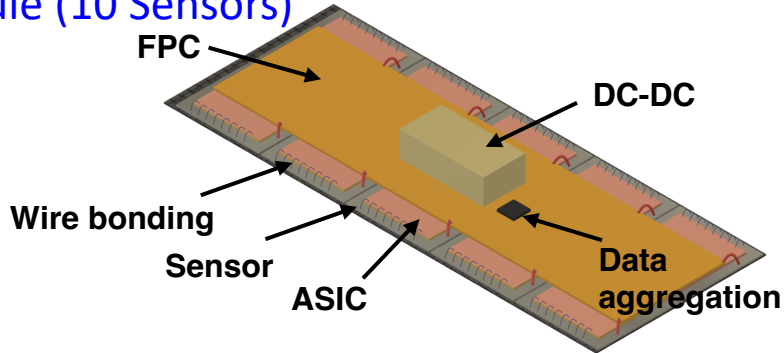

Ladder (17 or 18 modules)

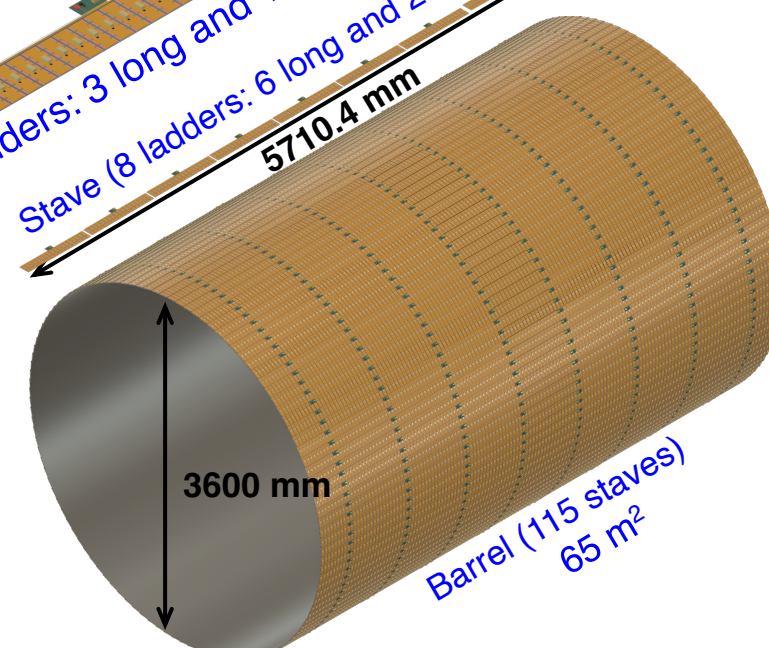
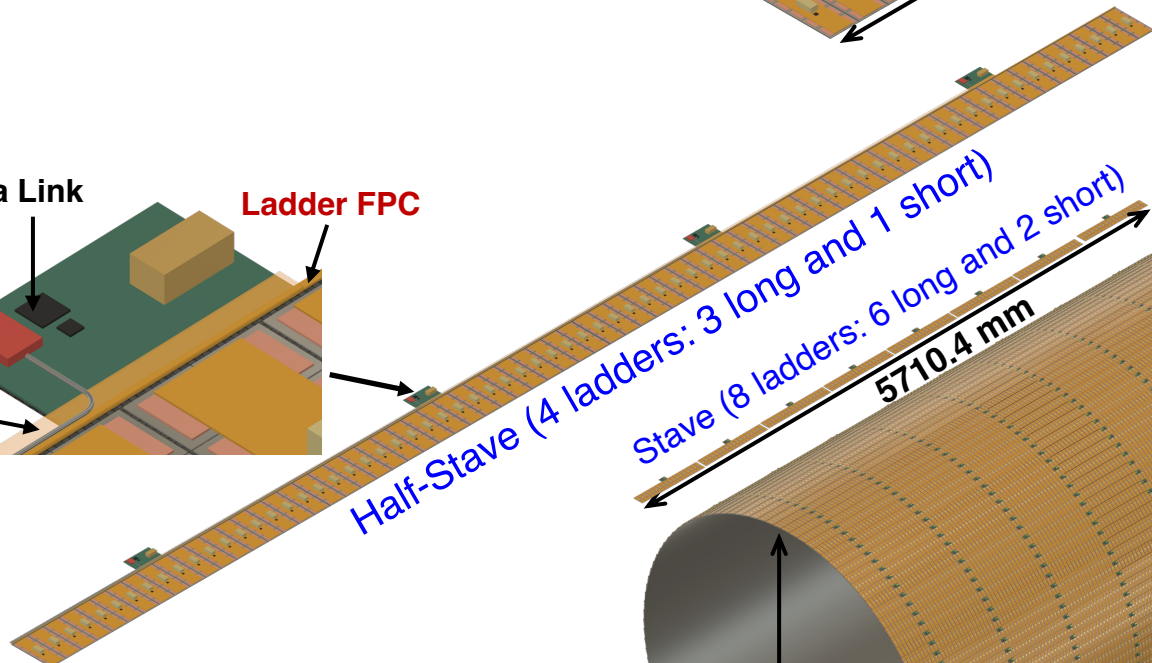
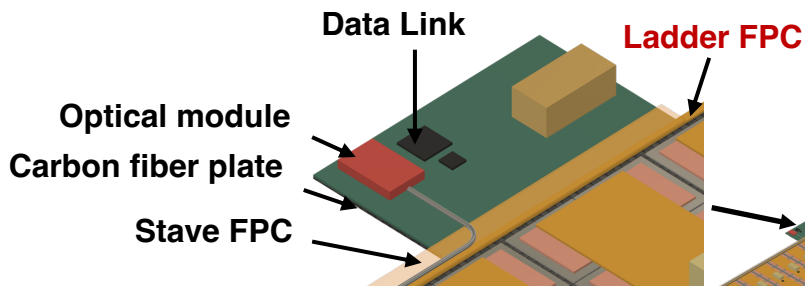
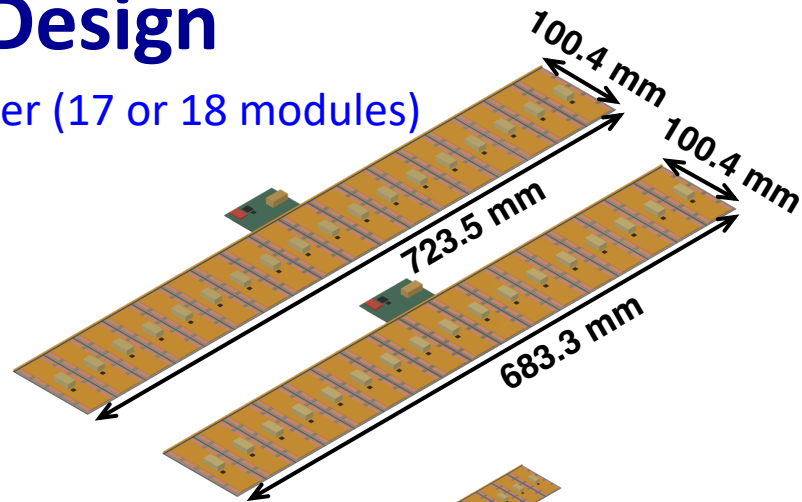

# ITK Endcap Cooling Simulation

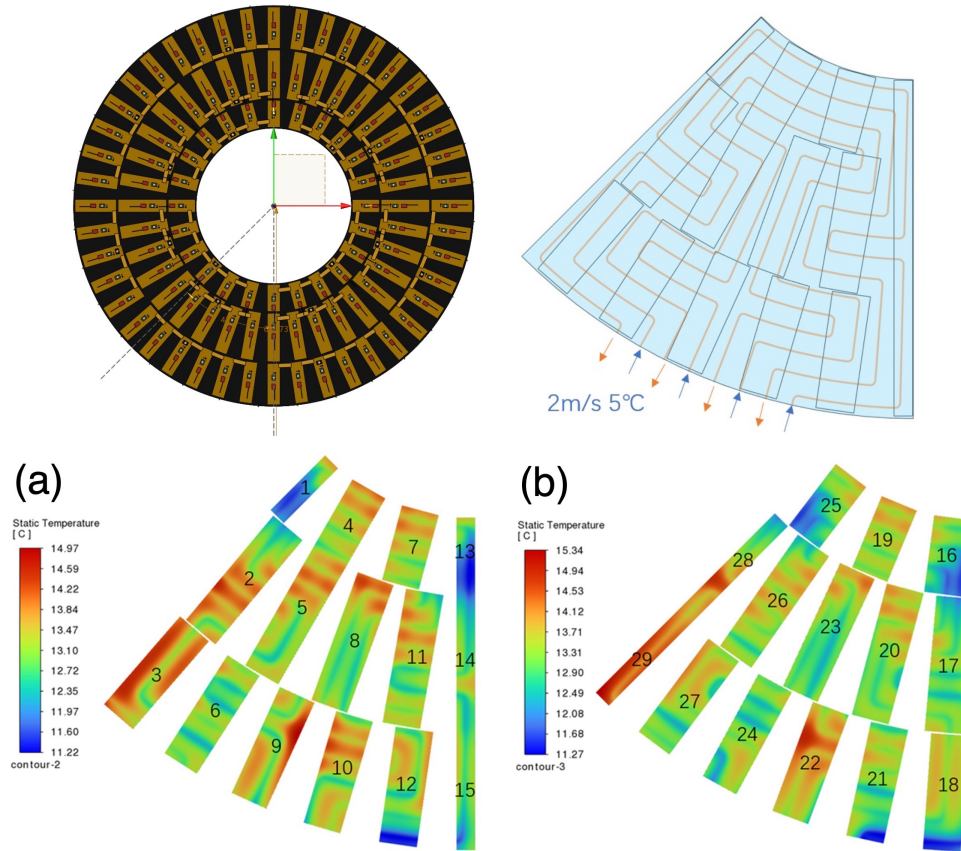

Based on these configurations, Figure 5.58 (a) and (b) shows the simulation results for the temperature distributions across both faces of the one eighth of the fourth ITK endcap (ITKE4). As shown, the temperature of all sensors on both faces remains below 15.3°C (well below the operation limit of 30°C). The maximum temperature difference across the plane is below 4°C, across one ITK module is below 3°C (see Fig 5.58 (c)), and across one ITK sensor is below 2.5°C (satisfying the requirement of <5°C). In all aspects, the cooling loop design with water cooling meets the detector's requirements. This confirms the effectiveness of the cooling design in maintaining both thermal uniformity and operational functionality.

