

Spin Teleportation of Protons at the MeV Scale





Dong Bai

Hohai University

C3NT Workshop: Quantum Information Science in High Energy
Nuclear Physics, Central China Normal University

June 17, 2026

Spin Teleportation via Bell-Triplet States Emergent from Proton-Proton Scattering

Z. X. Shen,^{1,2} H. Y. Shang,^{1,2} Y. G. Ma ,^{1,2,3,*} D. Bai ,^{4,†}
S. M. Wang ,^{1,2,‡} Z. C. Xu,^{1,2} Y. Ayyad ,^{5,§} and C. Filgueira⁵

¹*Key Laboratory of Nuclear Physics and Ion-beam Application (MOE),
Institute of Modern Physics, Fudan University, Shanghai 200433, China*

²*Shanghai Research Center for Theoretical Nuclear Physics,
NSFC and Fudan University, Shanghai 200438, China*

³*School of Physics, East China Normal University, Shanghai 200241, China*

⁴*College of Mechanics and Engineering Science, Hohai University, Nanjing, 211100, China*

⁵*IGFAE, Universidade de Santiago de Compostela, E-15782, Santiago de Compostela, Spain*

Entanglement is a key resource in quantum information science, yet its properties and applications in nuclear systems remain largely unexplored. Here, using proton-proton scattering as a quantum laboratory, we report the emergence of a near-pure Bell-triplet state at a laboratory energy of 151 MeV and a center-of-mass scattering angle of 90 degrees. In this unique kinematic regime, the scattering amplitude functions as a transition operator connecting distinct Bell states. Building upon this emergent resource, we propose a quantum teleportation protocol for proton spins, exploiting the intrinsic Hamiltonian of the strong interaction to perform the requisite Bell measurement. These findings effectively bridge few-body nuclear physics and quantum technology, establishing proton-proton scattering as both a source of high-fidelity entanglement and a natural processor for quantum information.

2510.24325, collaboration with **Fudan U.** (Zhaoxin Shen, Haoyu Shang, Yugang Ma, Simin Wang, Zicheng Xu)
and **IGFAE, Santiago** (Yassid Ayyad & Carolina Filgueira)

Entanglement in nuclear experiments

- **Existence (1976-2006) \Rightarrow Properties (2025-) \Rightarrow Applications?**
- **Existence of nuclear entanglement: nuclear Bell test**

1976



Wolfgang Mittig

- M. Laméhi-Rachti and **W. Mittig**, *Quantum mechanics and hidden variables: A test of Bell's inequality by the measurement of the spin correlation in low-energy proton-proton scattering*, Phys. Rev. D **14**, 2543 (1976).

2006



Hideyuki Sakai

- **H. Sakai**, T. Saito, T. Ikeda, K. Itoh, T. Kawabata, H. Kuboki, Y. Maeda, N. Matsui, C. Rangacharyulu, M. Sasano, Y. Satou, K. Sekiguchi, K. Suda, A. Tamii, T. Uesaka, and K. Yako, *Spin Correlations of Strongly Interacting Massive Fermion Pairs as a Test of Bell's Inequality*, Phys. Rev. Lett. **97**, 150405 (2006).

Spin-entangled (spin-singlet) proton pairs were generated in **two** different ways.

Experimental setups for nuclear Bell tests

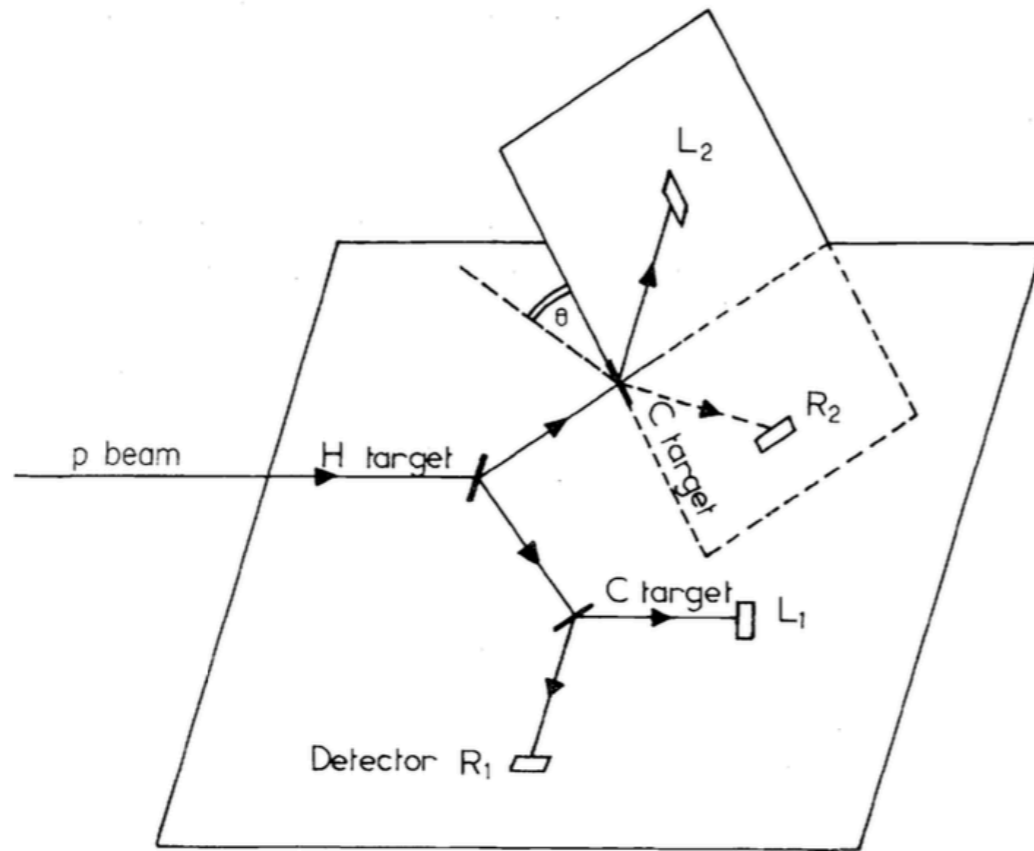

Mittig (1976)

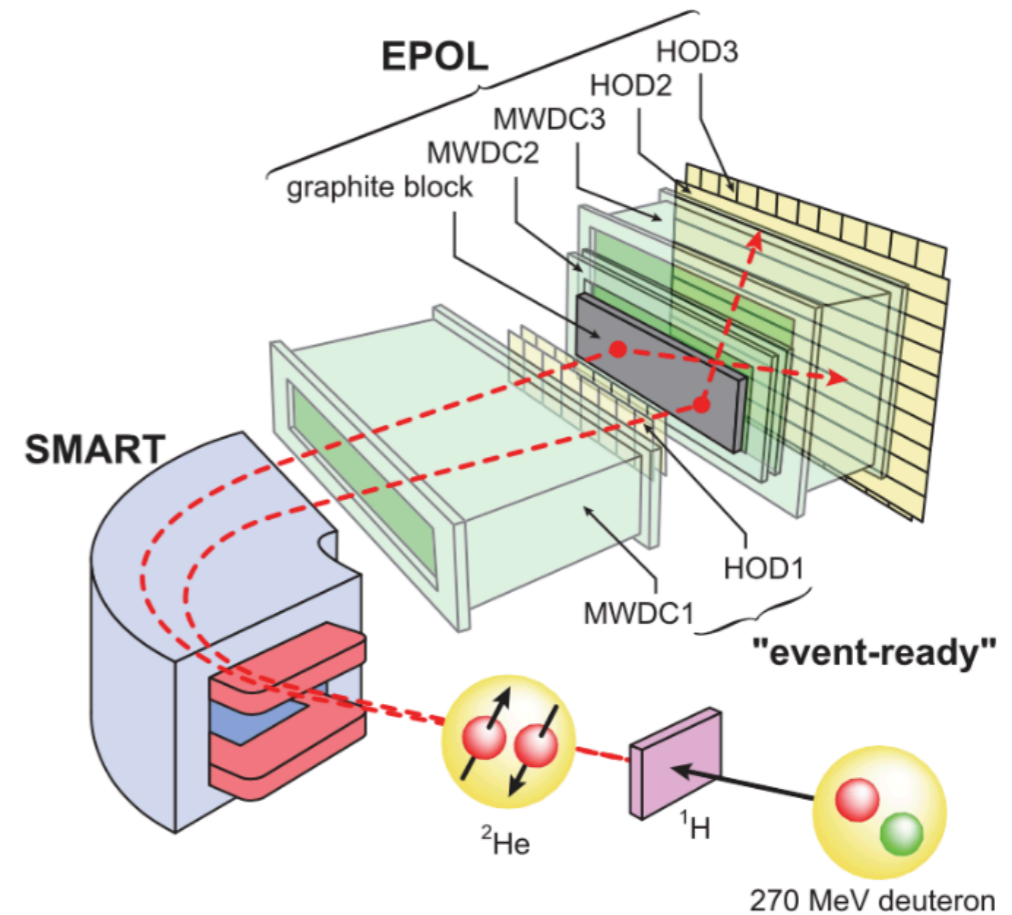

Sakai (2006)

Sakai (2006): “It is to be noted that the entanglement of the spin- singlet state was retained even when the two protons traversed through large amounts of material media (50 cm thick argon ethane gas in wire chambers, 1 cm thick plastic scintillators, and up to 5 cm thick graphite slab). It is indeed remarkable that the strongly interacting pairs maintain the correlations for distances greater than 10^{13} – 10^{14} times their coherence length, which was estimated to be 10^{-14} m (the size of a wave packet of two protons at production).”

• Properties of nuclear entanglement (2025-)

Led by **Hector & Yassid** from **IGFAE**, along with **FRIB** collaborators

Entanglement: A possible source of information on nuclear structure

H. Alvarez-Pol¹, Y. Ayyad¹, Y. Khelifi¹, W. Mittig², D. Bazin², D. Lee², **D. Bai³**, and A. Macchiavelli⁴

¹IGFAE, Universidade de Santiago de Compostela, E-15782, Santiago de Compostela, Spain

²Facility for Rare Isotope Beams, Michigan State University, East Lansing, Michigan 48824, USA

³College of Mechanics and Engineering Science, Hohai University, Nanjing 211100, China

⁴Physics Division, Oak Ridge National Laboratory, Oak Ridge, TN 37831, USA

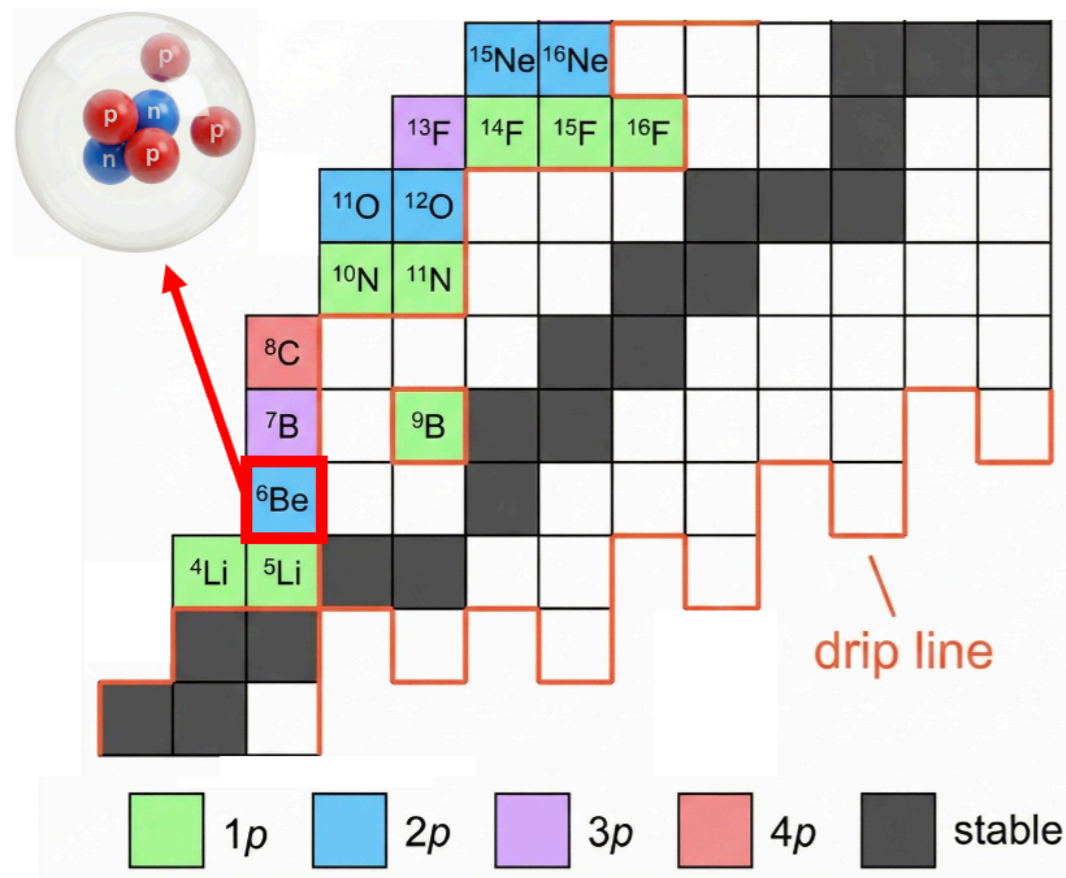

⁶Be: the lightest 2p emitter, $\alpha+p+p$.

Its ground state and the first 2⁺ excited state show a rich mix of **true**, **democratic**, and **sequential** 2p decays.

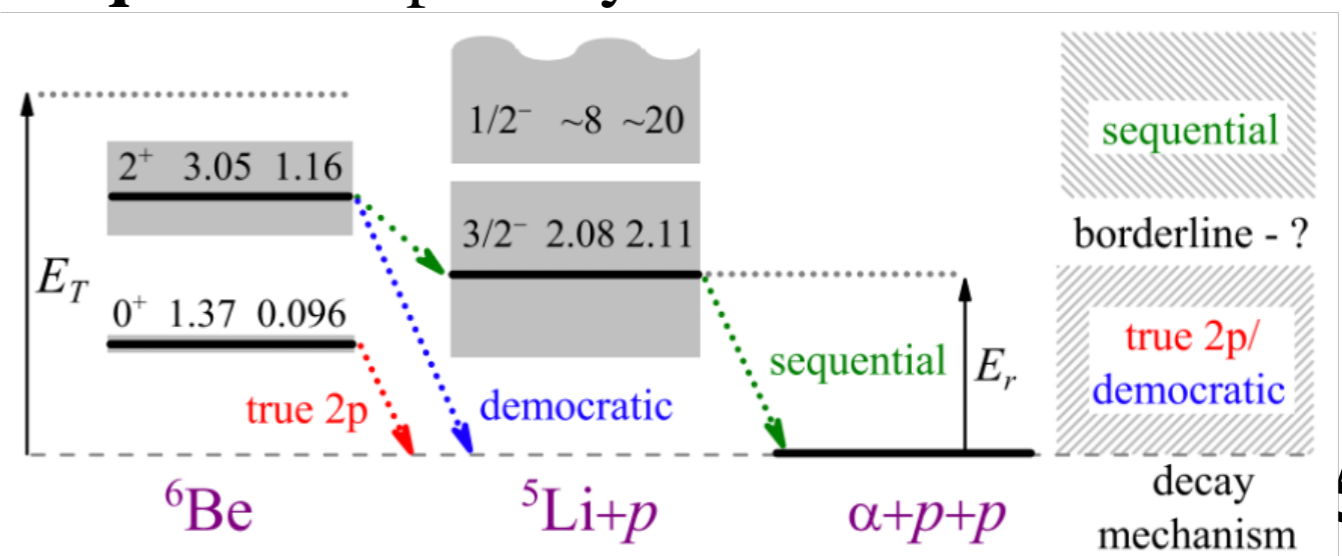

Quantum teleportation (Applications)

Quantum Teleportation (QT) enables the transfer of an **unknown quantum state** between distant qubits using entanglement.

Demonstrated in, e.g., **photons** and **superconducting circuits**.

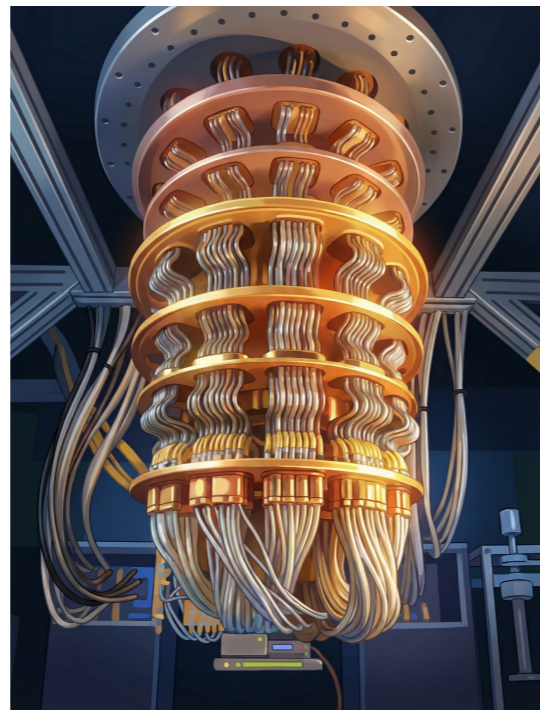
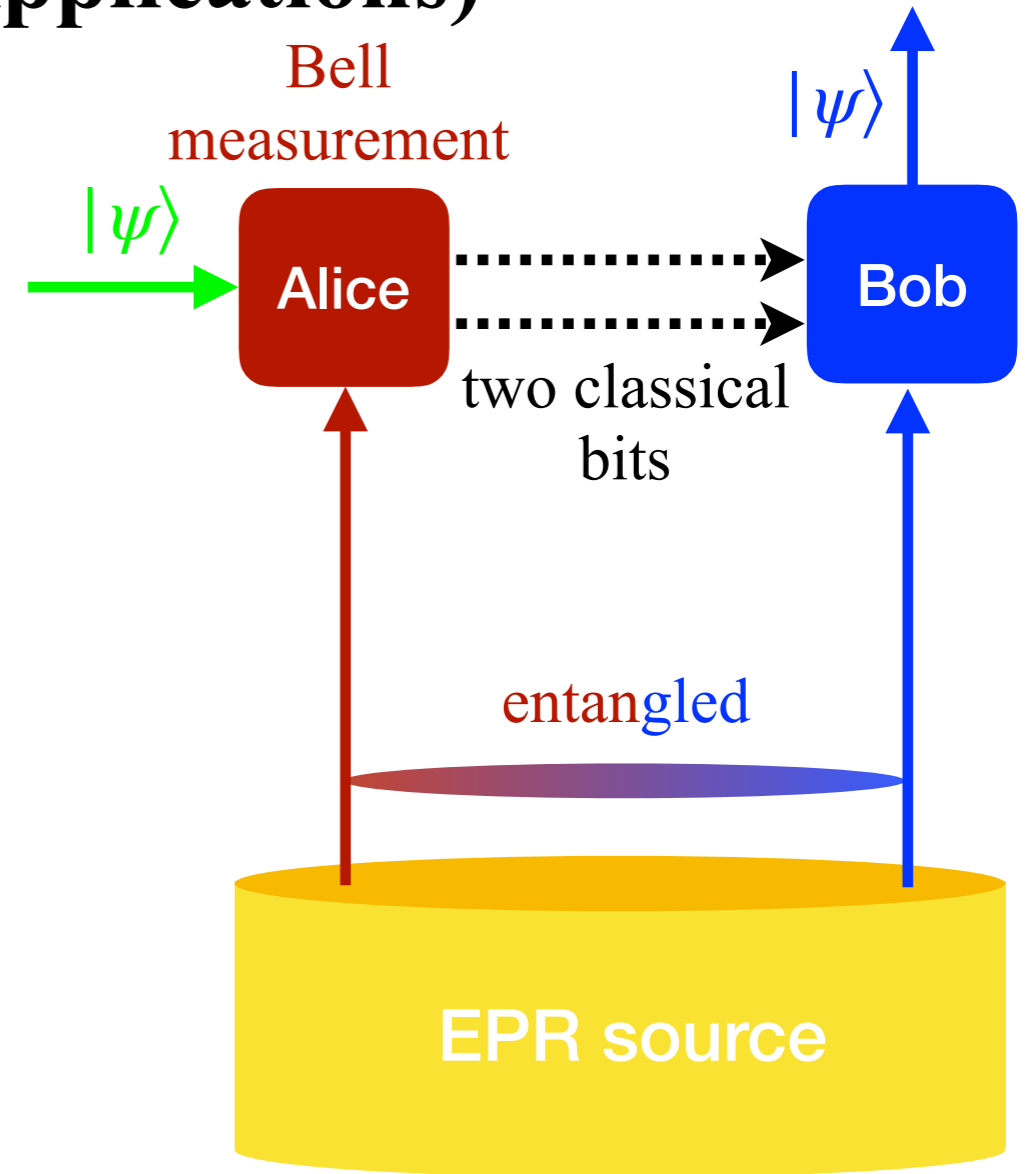

The quantum state carried by the **data qubit** transmitted intactly to the **target qubit** with the help of an entangled **ancilla qubit**.

PHYSICAL REVIEW LETTERS

VOLUME 70

29 MARCH 1993

NUMBER 13

Teleporting an Unknown Quantum State via Dual Classical and Einstein-Podolsky-Rosen Channels

Charles H. Bennett,⁽¹⁾ Gilles Brassard,⁽²⁾ Claude Crépeau,^{(2),(3)}
Richard Jozsa,⁽²⁾ Asher Peres,⁽⁴⁾ and William K. Wootters⁽⁵⁾

⁽¹⁾ *IBM Research Division, T.J. Watson Research Center, Yorktown Heights, New York 10598*

⁽²⁾ *Département IRO, Université de Montréal, C.P. 6128, Succursale "A", Montréal, Québec, Canada H3C 3J7*

⁽³⁾ *Laboratoire d'Informatique de l'École Normale Supérieure, 45 rue d'Ulm, 75230 Paris CEDEX 05, France^(a)*

⁽⁴⁾ *Department of Physics, Technion-Israel Institute of Technology, 32000 Haifa, Israel*

⁽⁵⁾ *Department of Physics, Williams College, Williamstown, Massachusetts 01267*

(Received 2 December 1992)



Charles Henry Bennett



Gilles Brassard



ACM A.M. Turing Award Honors Charles H. Bennett and Gilles Brassard for Foundational Contributions to Quantum Information Science

Breakthroughs in Quantum Cryptography and Quantum Teleportation Redefined Secure Communication and Computing

QT in nuclear physics?

- A quantum effect rarely demonstrated in nuclear physics at MeV energies.
- **INTACT** transmission of quantum states from the target nucleus. *In comparison, although traditional nuclear reactions do transfer quantum information, they typically transform quantum states, with details depending on reaction mechanism (often model dependent).*
- Paving the way to teleport quantum states of atomic nuclei to other platforms (trapped ions, superconducting circuits, etc)? *Performing quantum tasks (e.g., quantum state tomography) is very difficult for atomic nuclei, but can be quite easy for, e.g., trapped ions and superconducting circuits.*



- Pre-WWII ~ 1960s: **The era of vision & "scanning girls"**

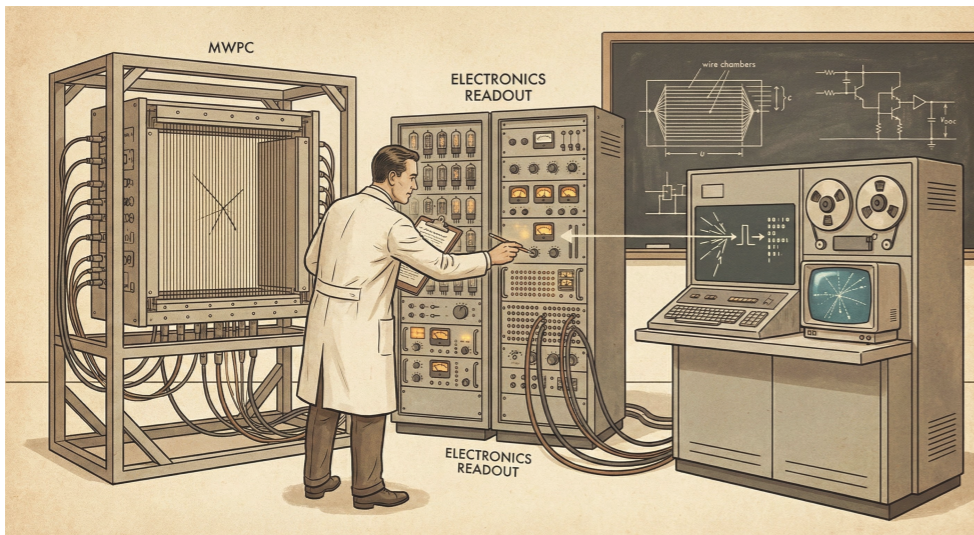

- 1968~present: **The Charpak revolution & the classical computer takeover**

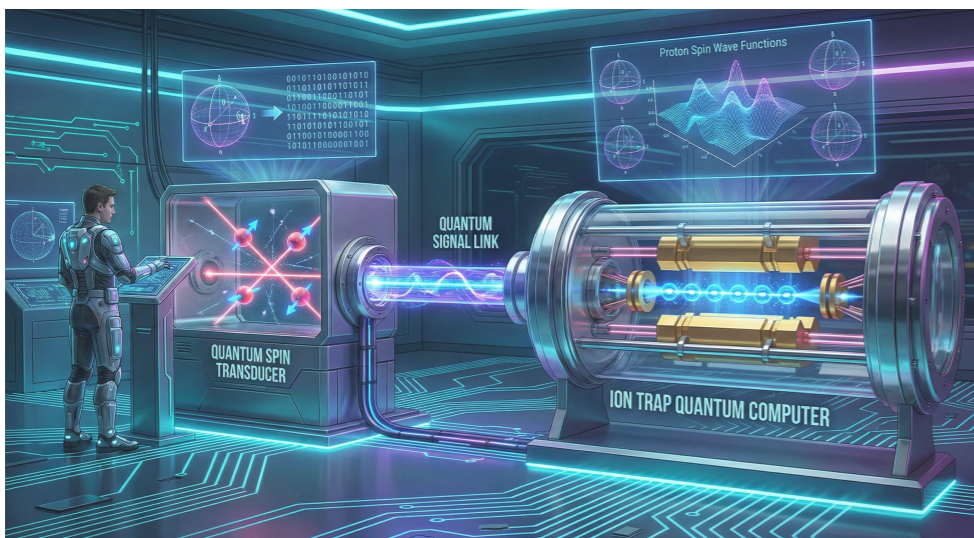

- 20XX~?: **The era of quantum devices?**
1. Teleport unknown quantum states between particles of **the same species**; ← **We are here.**
 2. Teleport unknown quantum states between particles of **different species**;
 3. Teleport unknown quantum states **across different energy scales.**

Mathematics of QT

- Alice has **an unknown quantum state** to be transferred to Bob

$$|\psi\rangle_1 = \alpha|0\rangle_1 + \beta|1\rangle_1.$$

- Alice and Bob share **a pair of maximally entangled qubits** (in one of the Bell states: **Alice: 2nd, Bob: 3rd**)

$$|\Psi^-\rangle_{23} = \frac{1}{\sqrt{2}}(|01\rangle_{23} - |10\rangle_{23}).$$

- For late convenience, the other three Bell states are given by

$$|\Psi^+\rangle_{23} = \frac{1}{\sqrt{2}}(|01\rangle_{23} + |10\rangle_{23}),$$

$$|\Phi^+\rangle_{23} = \frac{1}{\sqrt{2}}(|00\rangle_{23} + |11\rangle_{23}), \quad |\Phi^-\rangle_{23} = \frac{1}{\sqrt{2}}(|00\rangle_{23} - |11\rangle_{23}).$$

The Bell states are mutually orthogonal.

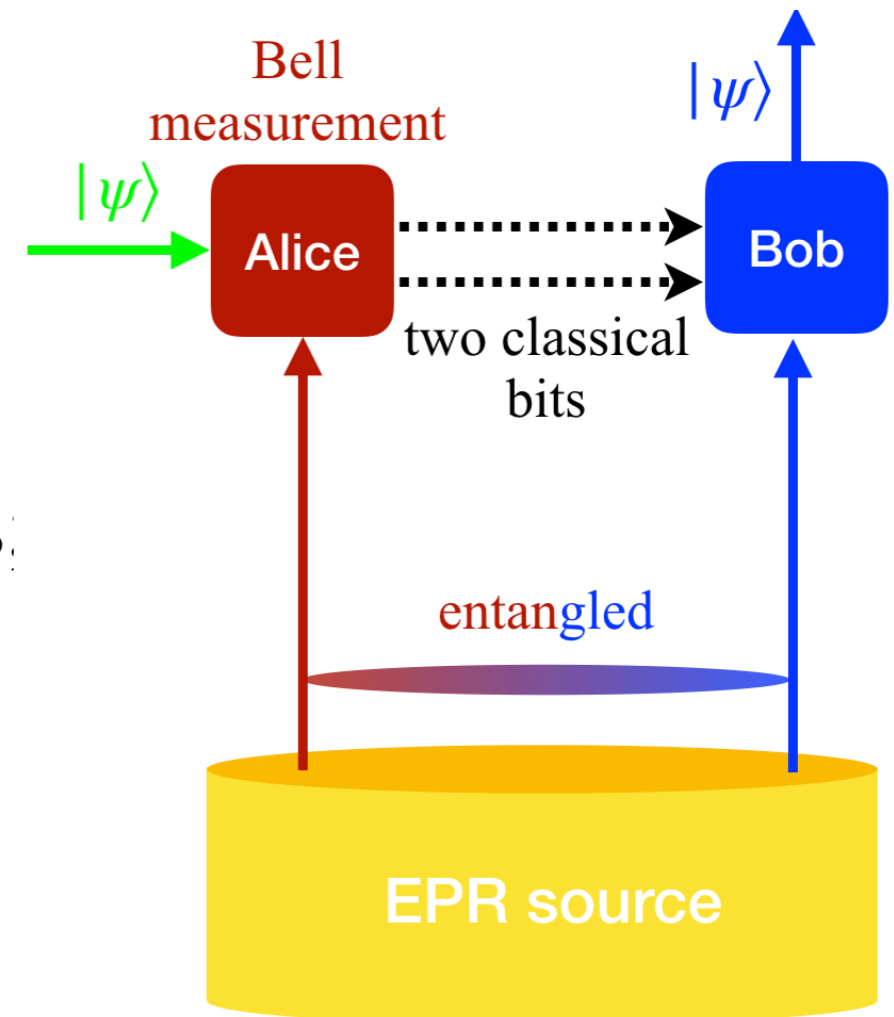

- The quantum state of three qubits is given by

$$\begin{aligned}
& |\psi\rangle_1 \otimes |\Psi^-\rangle_{23} \\
&= (\alpha|0\rangle_1 + \beta|1\rangle_1) \otimes \frac{1}{\sqrt{2}}(|01\rangle_{23} - |10\rangle_{23}) \\
&= \frac{1}{\sqrt{2}}(\alpha|001\rangle_{123} - \alpha|010\rangle_{123} + \beta|101\rangle_{123} - \beta|110\rangle_{123}) \\
&= \frac{1}{2} [|\Phi^+\rangle_{12} \otimes (\alpha|1\rangle_3 - \beta|0\rangle_3) \\
&\quad + |\Phi^-\rangle_{12} \otimes (\alpha|1\rangle_3 + \beta|0\rangle_3) \\
&\quad + |\Psi^+\rangle_{12} \otimes (-\alpha|0\rangle_3 + \beta|1\rangle_3) \\
&\quad + |\Psi^-\rangle_{12} \otimes (-\alpha|0\rangle_3 - \beta|1\rangle_3)]
\end{aligned}$$

- Alice** does quantum measurement for the **1st** and **2nd** qubits in Bell basis, aka **Bell measurement**.

- After **Bell measurement**, there are four possibilities, each with a probability of 1/4.

$$|\Phi^+\rangle_{12} \otimes (\alpha |1\rangle_3 - \beta |0\rangle_3),$$

$$|\Phi^-\rangle_{12} \otimes (\alpha |1\rangle_3 + \beta |0\rangle_3),$$

$$|\Psi^+\rangle_{12} \otimes (-\alpha |0\rangle_3 + \beta |1\rangle_3),$$

$$|\Psi^-\rangle_{12} \otimes (-\alpha |0\rangle_3 - \beta |1\rangle_3).$$

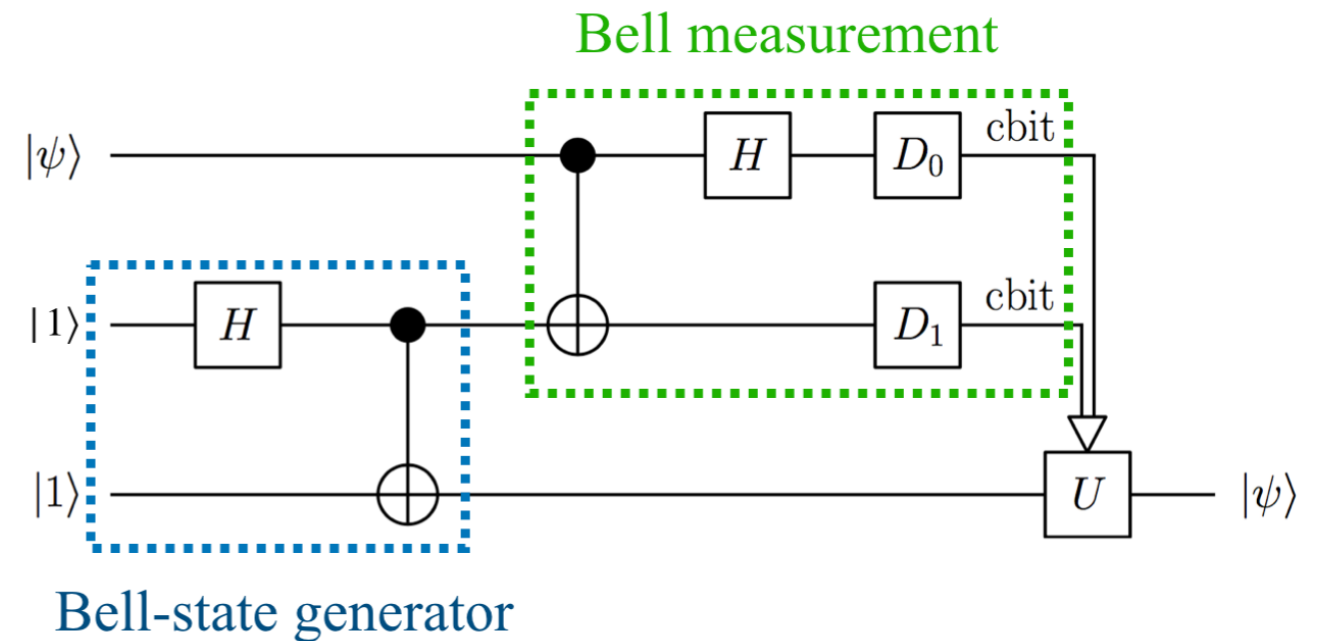

- Depending on the result of **Bell measurement** (encoded by **two** classical bits), **Bob** transforms his qubit (the **3rd** qubit) accordingly

$$\text{Alice: } |\Phi^+\rangle_{12} \Rightarrow \text{Bob: } ZX(\alpha |1\rangle_3 - \beta |0\rangle_3) = \alpha |0\rangle_3 + \beta |1\rangle_3,$$

$$\text{Alice: } |\Phi^-\rangle_{12} \Rightarrow \text{Bob: } X(\alpha |1\rangle_3 + \beta |0\rangle_3) = \alpha |0\rangle_3 + \beta |1\rangle_3,$$

$$\text{Alice: } |\Psi^+\rangle_{12} \Rightarrow \text{Bob: } Z(-\alpha |0\rangle_3 + \beta |1\rangle_3) = -(\alpha |0\rangle_3 + \beta |1\rangle_3),$$

$$\text{Alice: } |\Psi^-\rangle_{12} \Rightarrow \text{Bob: } -(\alpha |0\rangle_3 + \beta |1\rangle_3).$$

Three ingredients of QT

- *Sources of entangled pairs*

- ➔ **How to generate entangled proton pairs?**

1. Elastic proton-proton scattering [W. Mittig (1976)];
2. $p(d,2p)n$ [H. Sakai (2006)];
3. $2p$ radioactivity from, e.g., ${}^6\text{Be}$;
4. ...

- *Bell measurement*

- ➔ **How to do Bell measurement for protons?**

Make use of proton-proton scattering at **specific kinematics**:

1. $T_{\text{lab}} < 10$ MeV
2. $(T_{\text{lab}}, \theta_{\text{CM}}) = (151 \text{ MeV}, 90^\circ)$

- *Classical information transmission*

- ➔ **What classical information is needed to be transmitted?**

One classical bit to tell whether the wanted proton-proton scattering happens or not.

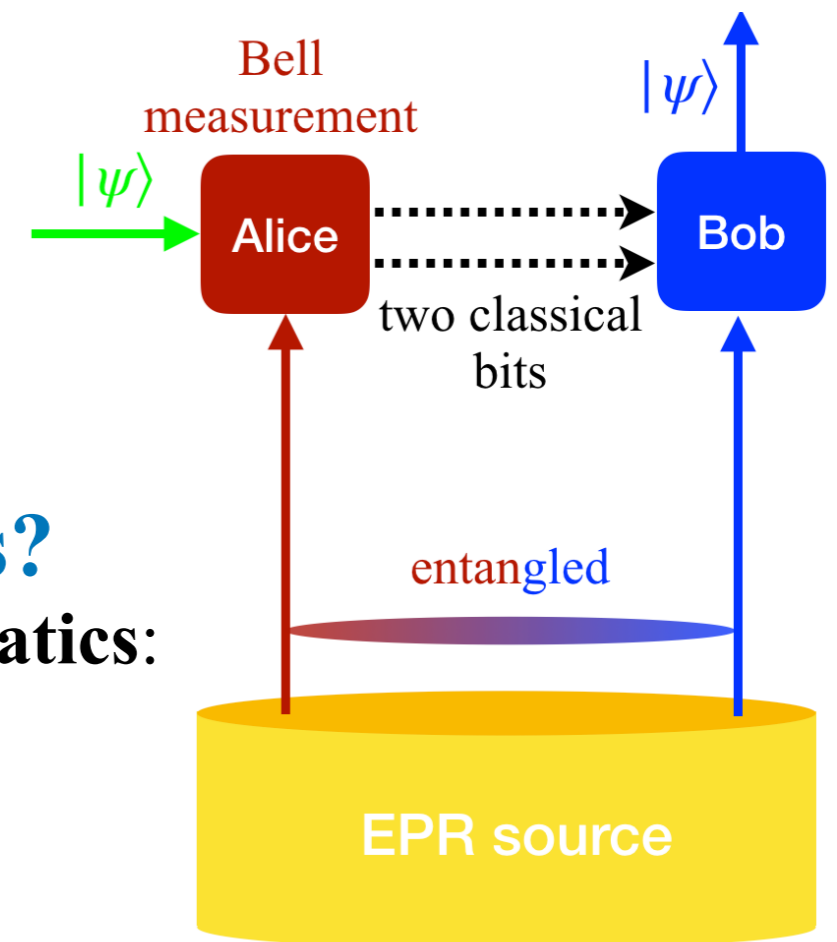

Proton-proton scattering

Information of proton-proton scattering is encoded by **spin amplitude** $M(E, \theta)$

$$\rho_{\text{fin}} = M\rho_{\text{init}}M^\dagger \Rightarrow \text{entanglement measures}$$

Concurrence: $C(\rho_{\text{fin}}) = \max\{0, \lambda_1 - \lambda_2 - \lambda_3 - \lambda_4\} \in [0, 1]$, with λ_i the eigenvalue of $R = [\sqrt{\rho}(\sigma_y \otimes \sigma_y)\rho_{\text{fin}}^*(\sigma_y \otimes \sigma_y)\sqrt{\rho}]^{1/2}$ in decreasing order.

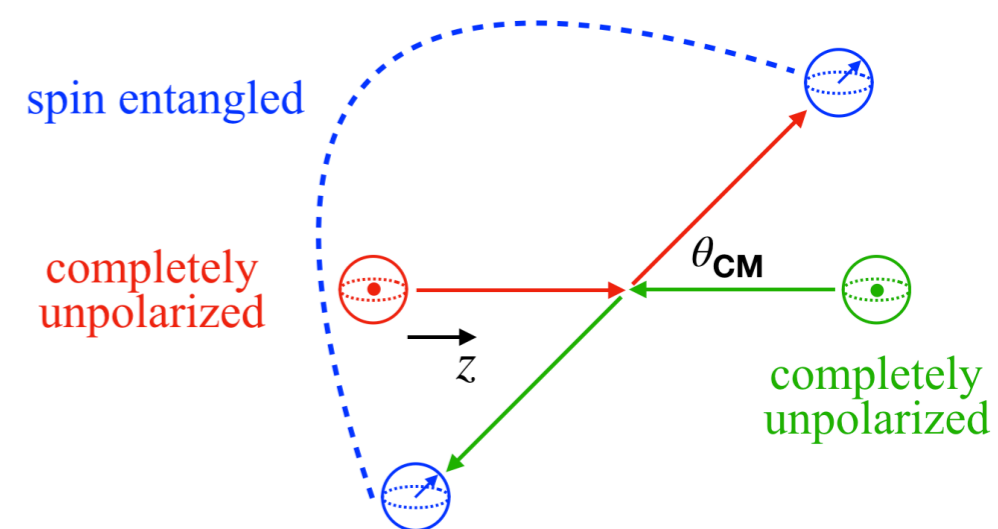
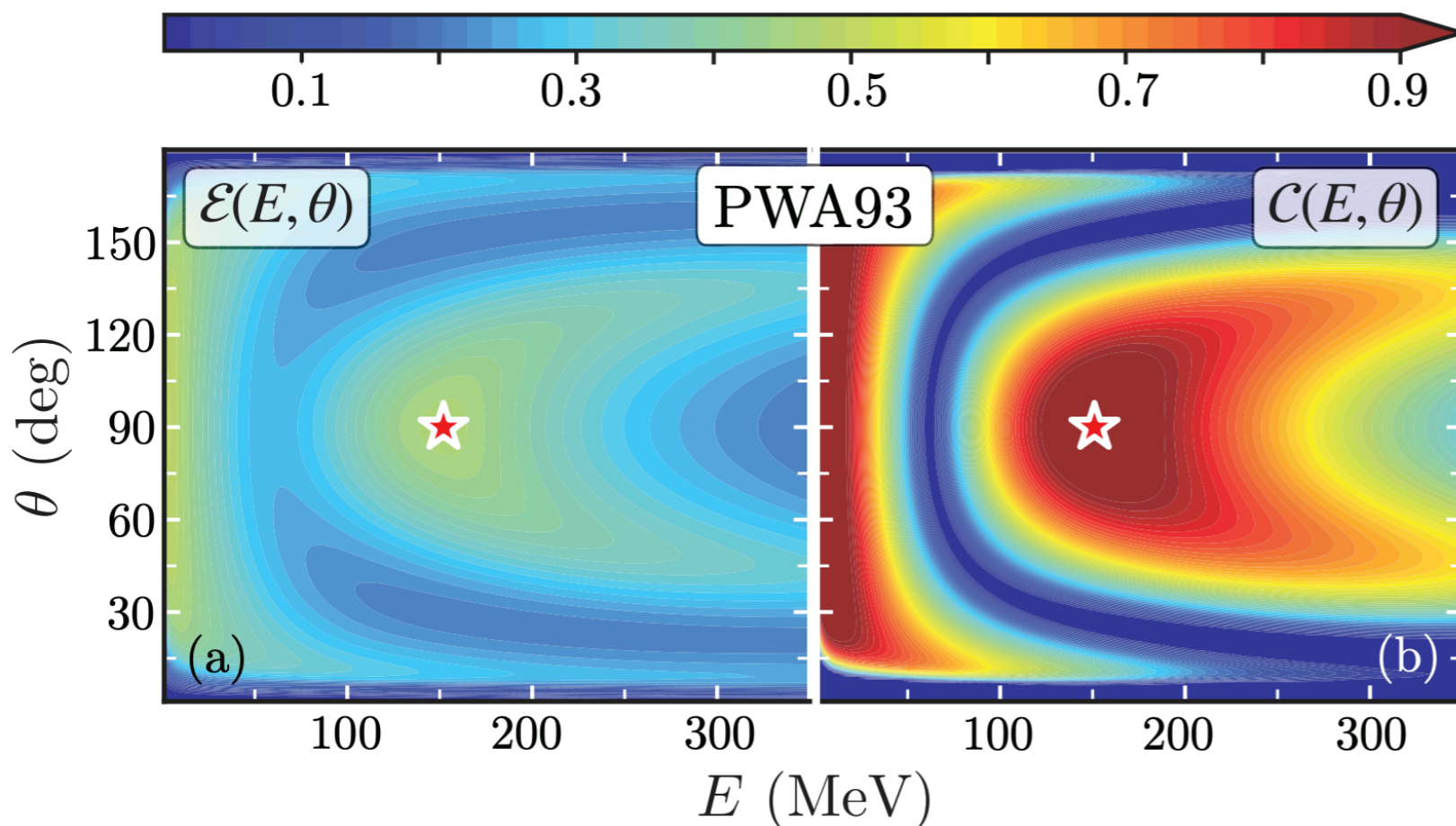

Two special regions support large spin entanglement.

- At $E < 10$ MeV, **Bell projection operator**

$$M \propto |\Psi^-\rangle\langle\Psi^-|$$

$$|\Psi^-\rangle = \frac{1}{\sqrt{2}}(|01\rangle - |10\rangle)$$

S -wave dominance at low energy.

- At $(E, \theta) = (151 \text{ MeV}, 90^\circ)$,

$$M \propto |\Psi^+\rangle\langle\Phi^-| \quad \text{Bell transition operator}$$

$$|\Psi^+\rangle = \frac{1}{\sqrt{2}}(|01\rangle + |10\rangle) \quad |\Phi^-\rangle = \frac{1}{\sqrt{2}}(|00\rangle - |11\rangle)$$

Explicitly, $M =$

$$\begin{pmatrix} 0 & 0.17199 + 0.066145 i & 0.17199 + 0.066145 i & 0 \\ -1.92264 - 0.029195 i & 0.0671124 + 0.0728236 i & -0.0671124 - 0.0728236 i & 1.92264 + 0.029195 i \\ -1.92264 - 0.029195 i & -0.0671124 - 0.0728236 i & 0.0671124 + 0.0728236 i & 1.92264 + 0.029195 i \\ 0 & -0.17199 - 0.066145 i & -0.17199 - 0.066145 i & 0 \end{pmatrix}$$

small

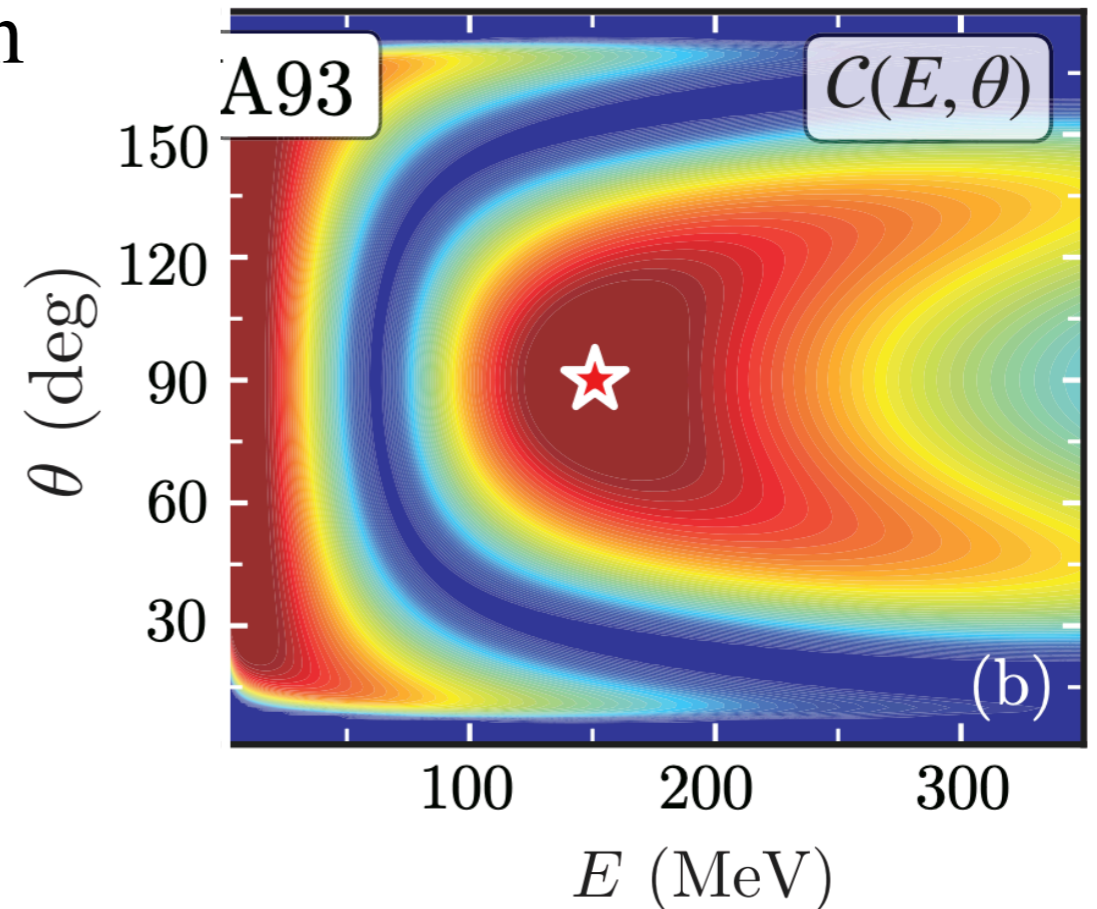

Physical origins

Bell-triplet fraction W_{10} in AV series of nuclear forces.

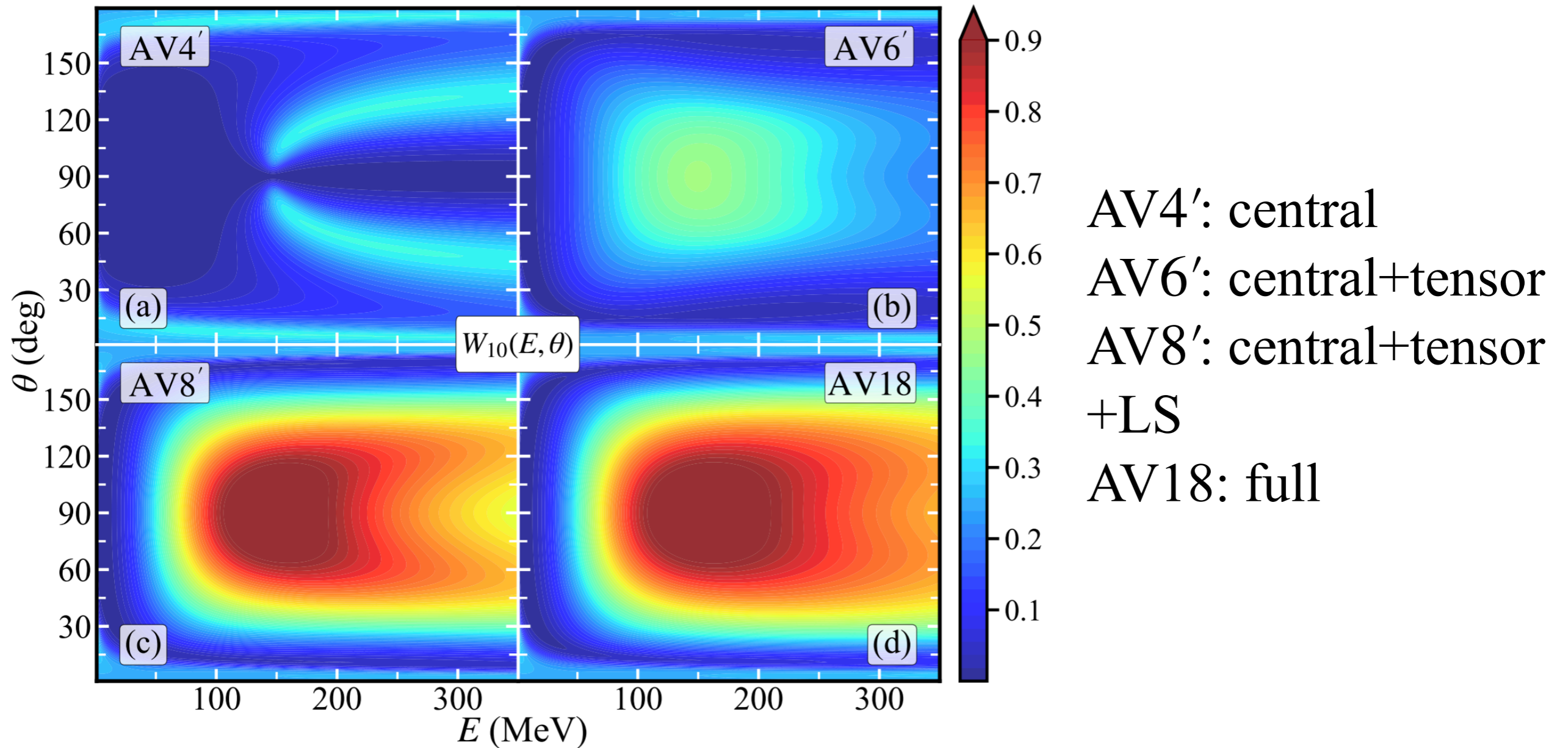

A joint contribution from tensor and LS forces.

Saclay amplitude

$$M = \frac{1}{2} \left[(a+b) \mathbf{1}_4 + (a-b) (\boldsymbol{\sigma}_1 \cdot \hat{\mathbf{n}}) (\boldsymbol{\sigma}_2 \cdot \hat{\mathbf{n}}) + (c+d) (\boldsymbol{\sigma}_1 \cdot \hat{\mathbf{m}}) (\boldsymbol{\sigma}_2 \cdot \hat{\mathbf{m}}) + (c-d) (\boldsymbol{\sigma}_1 \cdot \hat{\mathbf{l}}) (\boldsymbol{\sigma}_2 \cdot \hat{\mathbf{l}}) \right. \\ \left. + e [(\boldsymbol{\sigma}_1 \cdot \hat{\mathbf{n}}) + (\boldsymbol{\sigma}_2 \cdot \hat{\mathbf{n}})] \right]$$

For identical particles

$$a = 0, \quad c = -b.$$

Write M at 90° in Bell basis $\{|\Psi^-\rangle, |\Psi^+\rangle, |\Phi^+\rangle, |\Phi^-\rangle\}$

$$M_{\text{Bell}}^{pp} = \begin{pmatrix} 2b & 0 & 0 & 0 \\ 0 & 0 & 0 & -(d - ie) \\ 0 & 0 & 0 & 0 \\ 0 & -(d + ie) & 0 & 0 \end{pmatrix} \begin{matrix} |\Psi^-\rangle \\ |\Psi^+\rangle \\ |\Phi^+\rangle \\ |\Phi^-\rangle \end{matrix}$$

$$\begin{matrix} |\Psi^-\rangle & |\Psi^+\rangle & |\Phi^+\rangle & |\Phi^-\rangle \end{matrix}$$

In the limit of $b \rightarrow 0$ and $d + ie \rightarrow 0$, $M_{\text{Bell}}^{pp} = -(d - ie) |\Psi^+\rangle \langle \Phi^-|$.

Saclay amplitude and W_{10}

Potential	$ d - ie $	$ d + ie $	$2 b $	W_{10}
AV4'	0.002	0.002	0.200	0.0001
AV6'	2.011	2.155	0.200	0.463
AV8'	3.779	0.362	0.200	0.988
AV18	3.862	0.383	0.164	0.989

Translation to partial-wave conditions

Condition	Saclay form	Partial-wave form	Physical meaning
$d + ie \rightarrow 0$	$M_{10} \rightarrow 0$	$T_2 = T_0$, i.e., $\delta_{3P_2} = \delta_{3P_0}$	Accidental J -degeneracy
$b \rightarrow 0$	1S_0 amplitude vanishes	$\delta_{1S_0} \rightarrow 0$	S -wave Ramsauer transparency

Phase shifts patterns at 151 MeV.

Potential	δ_{3P_0}	δ_{3P_1}	δ_{3P_2}	Pattern
AV4'	-3.1°	-3.1°	-3.1°	All degenerate
AV6'	$+22.6^\circ$	-13.1°	$+0.6^\circ$	Tensor splits $J = 0$ upward
AV8'	$+4.4^\circ$	-17.3°	$+13.8^\circ$	LS reshapes: $J = 2$ up, $J = 0$ down
AV18	$+4.4^\circ$	-17.4°	$+14.3^\circ$	Nearly identical to AV8'

Chiral EFT

Bell transition operator emerges only at NLO and beyond. LS force appears as contact terms at NLO (integrating out heavy mesons).

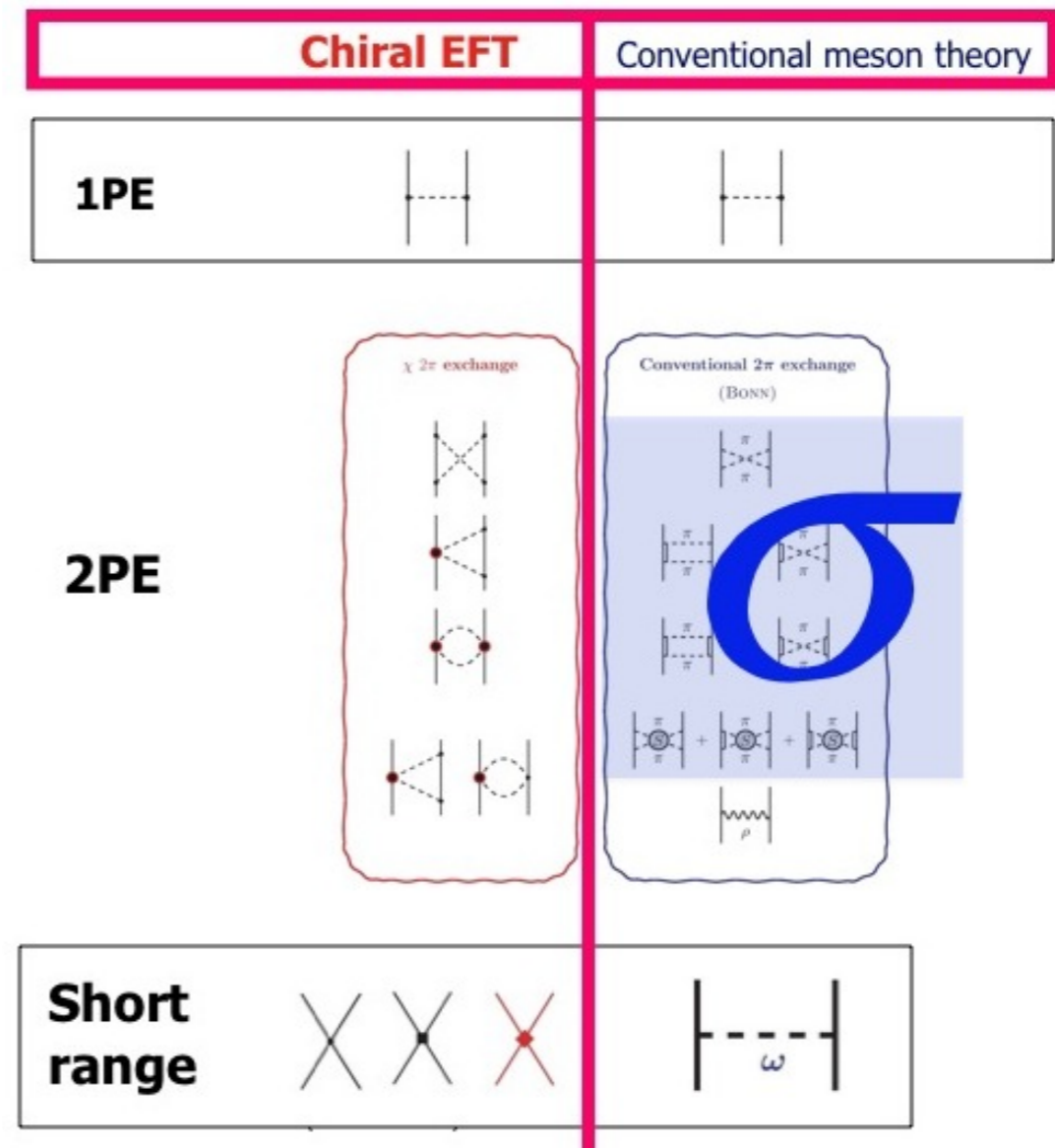
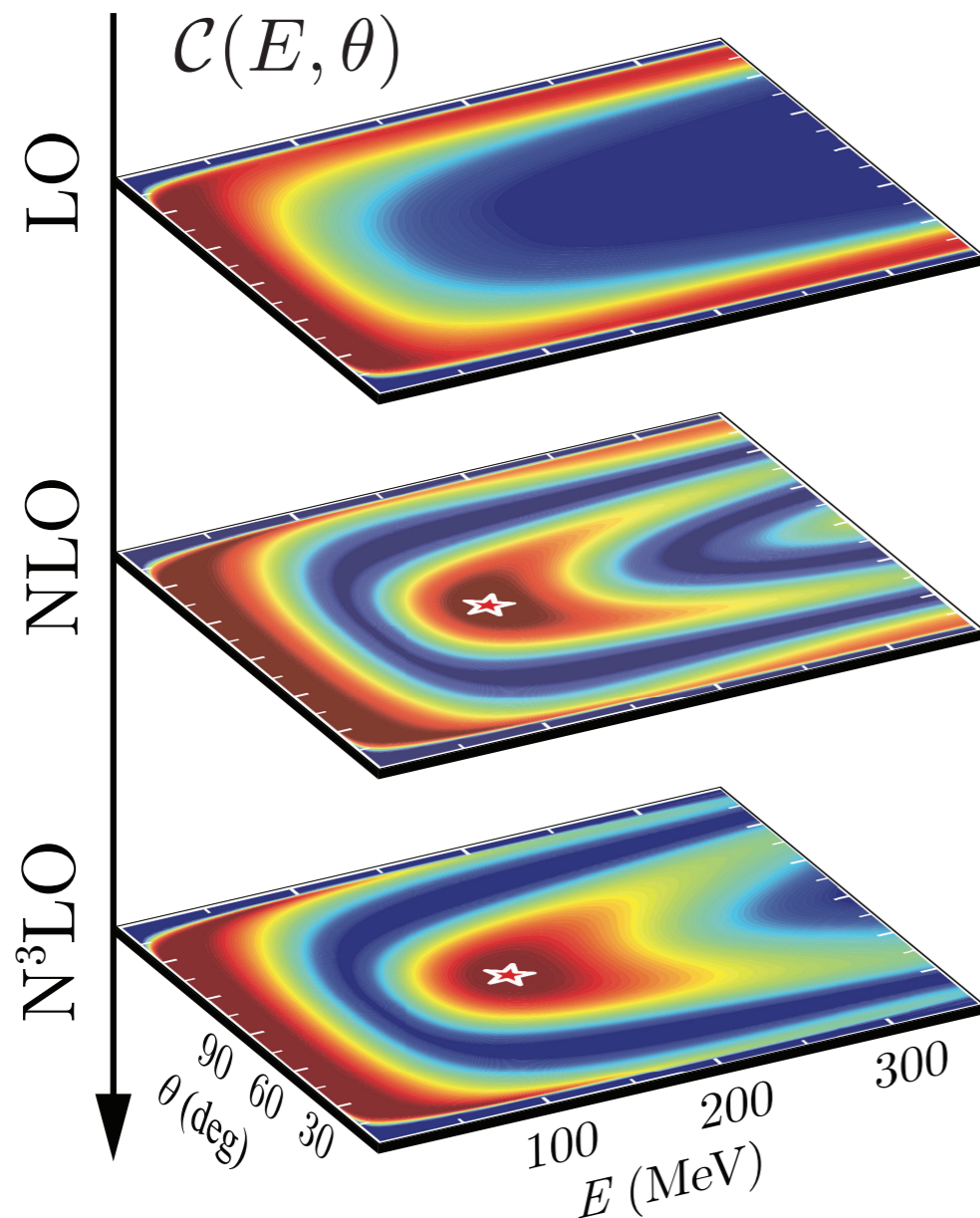

Machleidt (2014)

Spin teleportation < 10 MeV

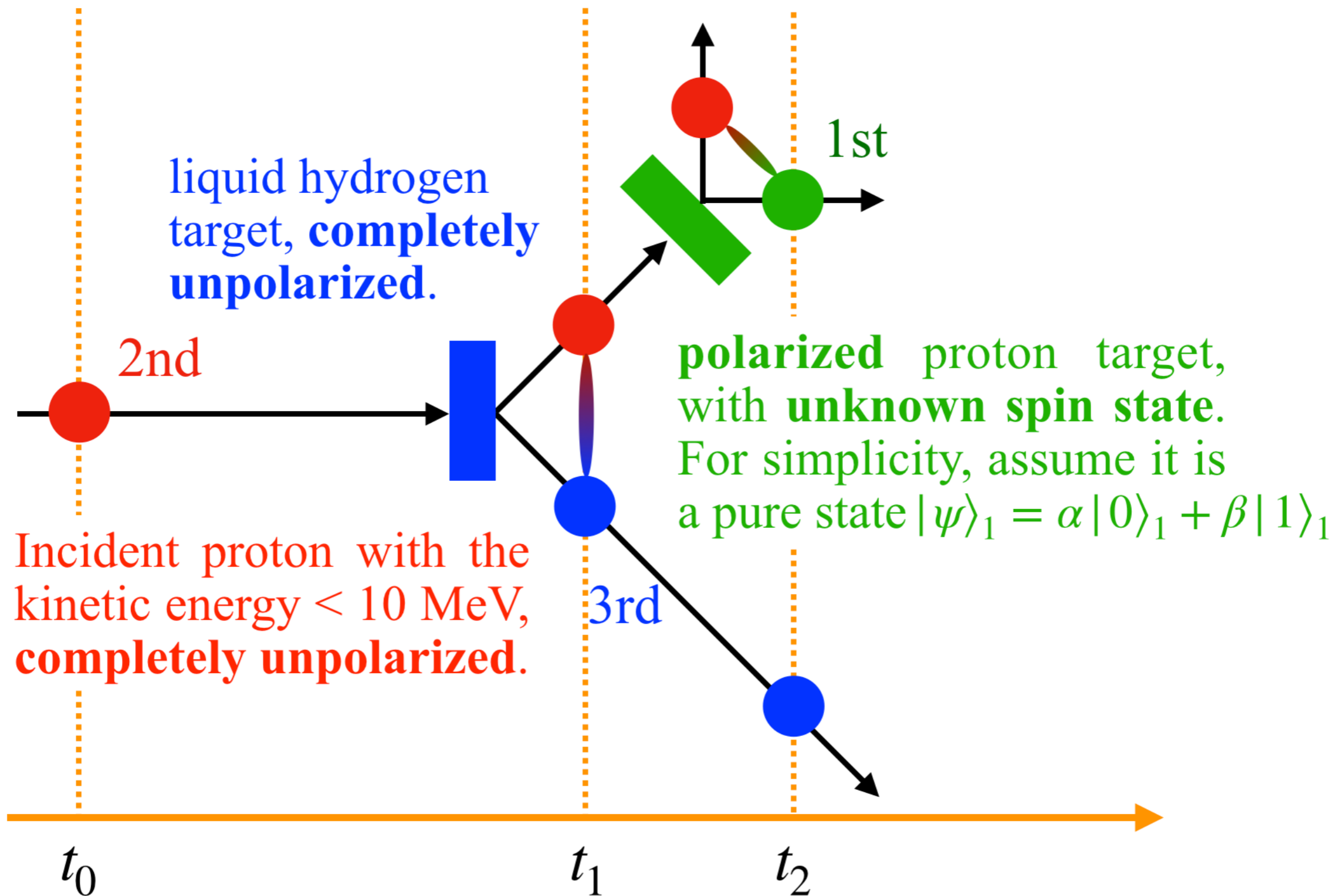

$$\mathbf{t}_0 : |\psi\rangle_1 \langle\psi|_1 \otimes \frac{I}{2} \otimes \frac{I}{2}$$

$$\mathbf{t}_1 : |\psi\rangle_1 \langle\psi|_1 \otimes \left[M_{23} \left(\frac{I}{2} \otimes \frac{I}{2} \right) M_{23}^\dagger \right]$$

$$\Rightarrow |\psi\rangle_1 \otimes |\Psi^-\rangle_{23} \text{ pure state}$$

$$= \frac{1}{2} [|\Phi^+\rangle_{12} \otimes (\alpha|1\rangle_3 - \beta|0\rangle_3) + |\Phi^-\rangle_{12} \otimes (\alpha|1\rangle_3 + \beta|0\rangle_3) \\ + |\Psi^+\rangle_{12} \otimes (-\alpha|0\rangle_3 + \beta|1\rangle_3) + |\Psi^-\rangle_{12} \otimes (-\alpha|0\rangle_3 - \beta|1\rangle_3)]$$

$$\mathbf{t}_2 : (M_{12} \otimes I) \frac{1}{2} [\dots + |\Psi^-\rangle_{12} \otimes (-\alpha|0\rangle_3 - \beta|1\rangle_3)]$$

$$\rightarrow |\Psi^-\rangle_{12} \otimes (-\alpha|0\rangle_3 - \beta|1\rangle_3) \quad \downarrow$$

- The unknown spin state of the polarized hydrogen target is teleported to the 3rd proton some distance away.
- The polarization of the 3rd proton can be measured and compared to that provided by the producer of the polarized target.

Spin teleportation at 151 MeV

- Produce spin-entangled proton pairs by, e.g., $p(d,2p)n$ following Sakai (2006) and select two-proton events with relative energies < 1 MeV; deuteron at 302 MeV \rightarrow two protons at 151 MeV.

Incident two protons with the kinetic energy 151 MeV, spin-singlet state.

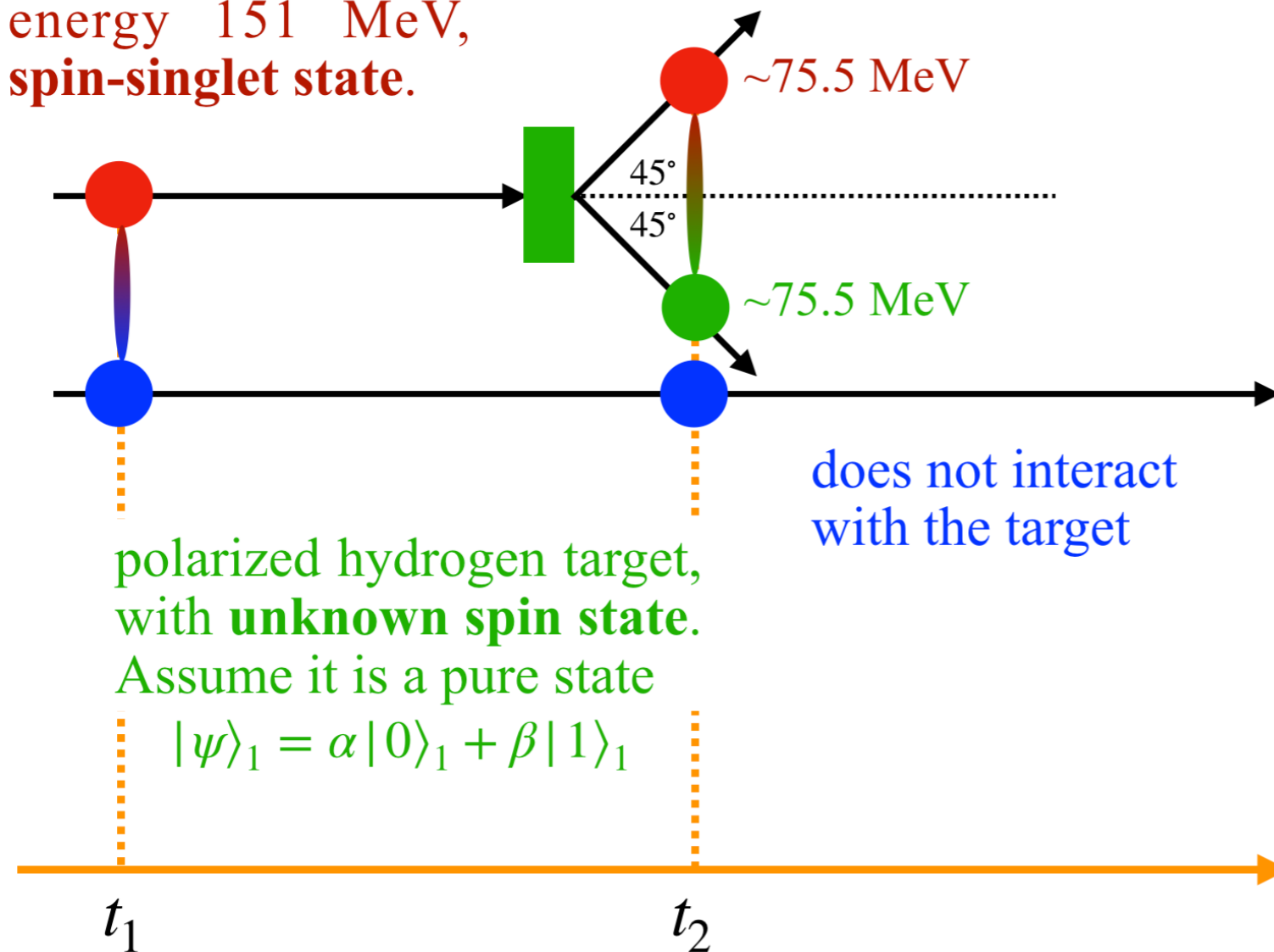

$$\begin{aligned}
 t_1: & |\psi\rangle_1 \otimes |\Psi^-\rangle_{23} \\
 &= \frac{1}{2} [|\Phi^+\rangle_{12} \otimes (\alpha|1\rangle_3 - \beta|0\rangle_3) \\
 &+ |\Phi^-\rangle_{12} \otimes (\alpha|1\rangle_3 + \beta|0\rangle_3) \\
 &+ |\Psi^+\rangle_{12} \otimes (-\alpha|0\rangle_3 + \beta|1\rangle_3) \\
 &+ |\Psi^-\rangle_{12} \otimes (-\alpha|0\rangle_3 - \beta|1\rangle_3)]
 \end{aligned}$$

$$\begin{aligned}
 t_2: & (M_{12} \otimes I) |\psi\rangle_1 \otimes |\Psi^-\rangle_{23} \\
 & \rightarrow |\Psi^+\rangle_{12} \otimes (\alpha|1\rangle_3 + \beta|0\rangle_3)
 \end{aligned}$$

$$M_{12} \propto |\Psi^+\rangle_{12} \langle \Phi^-|_{12}$$

equal to $|\psi\rangle_1 = \alpha|0\rangle_1 + \beta|1\rangle_1$ up to the inversion of the z-axis.

Spin teleportation with polarized deuteron beams

- A polarized deuteron beam in the $m_S = 0$ state onto a polarized proton target;
- a proton-neutron pair in Bell-triplet state.
- In quasi-free scattering (QFS) at ~ 151 MeV/A, the proton inside the deuteron scatters off the target proton as if in free space, leaving the neutron as a spectator. Then, the spin state of the target proton would then be teleported to the spectator neutron.

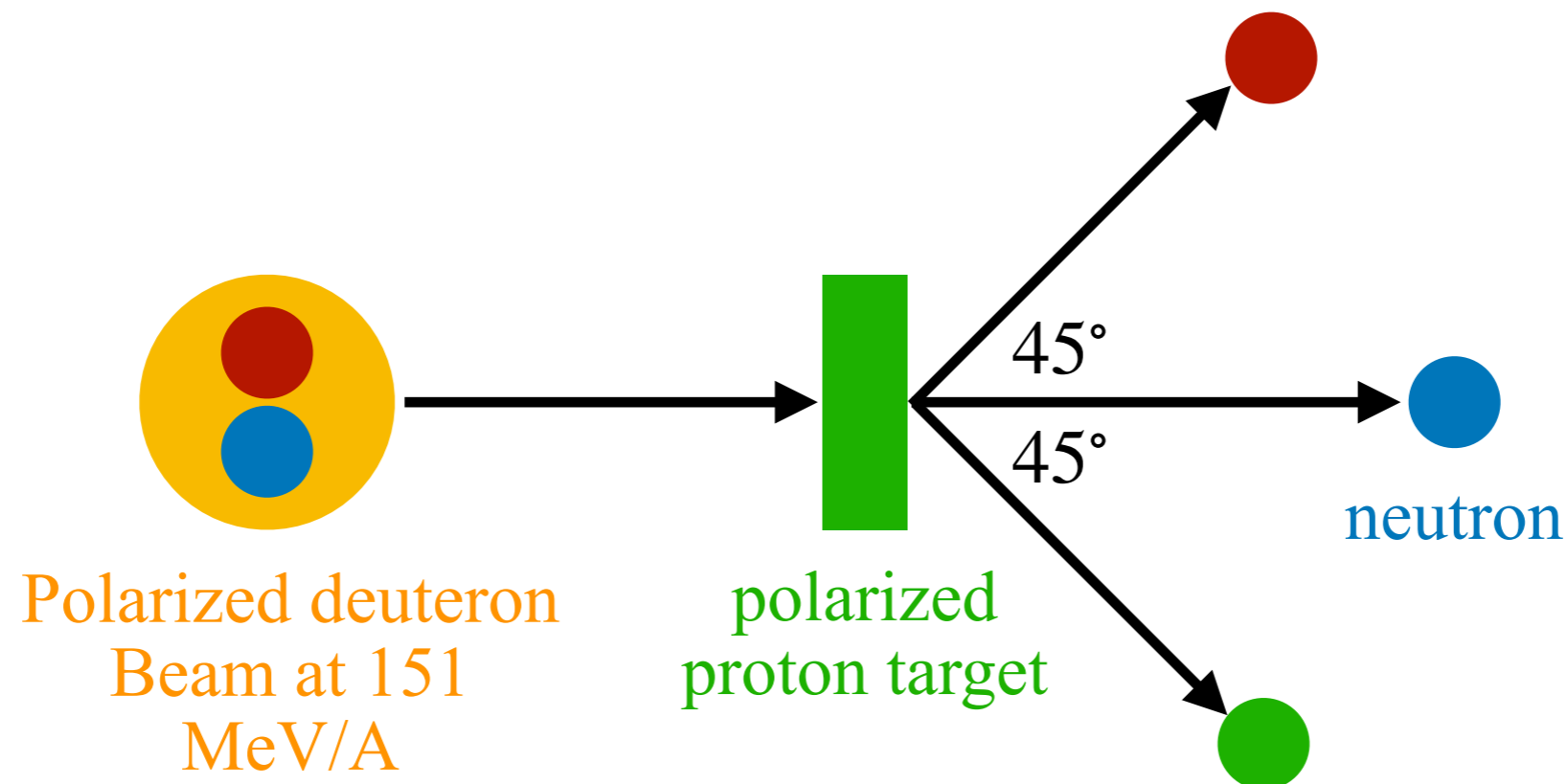

Classical information transmission

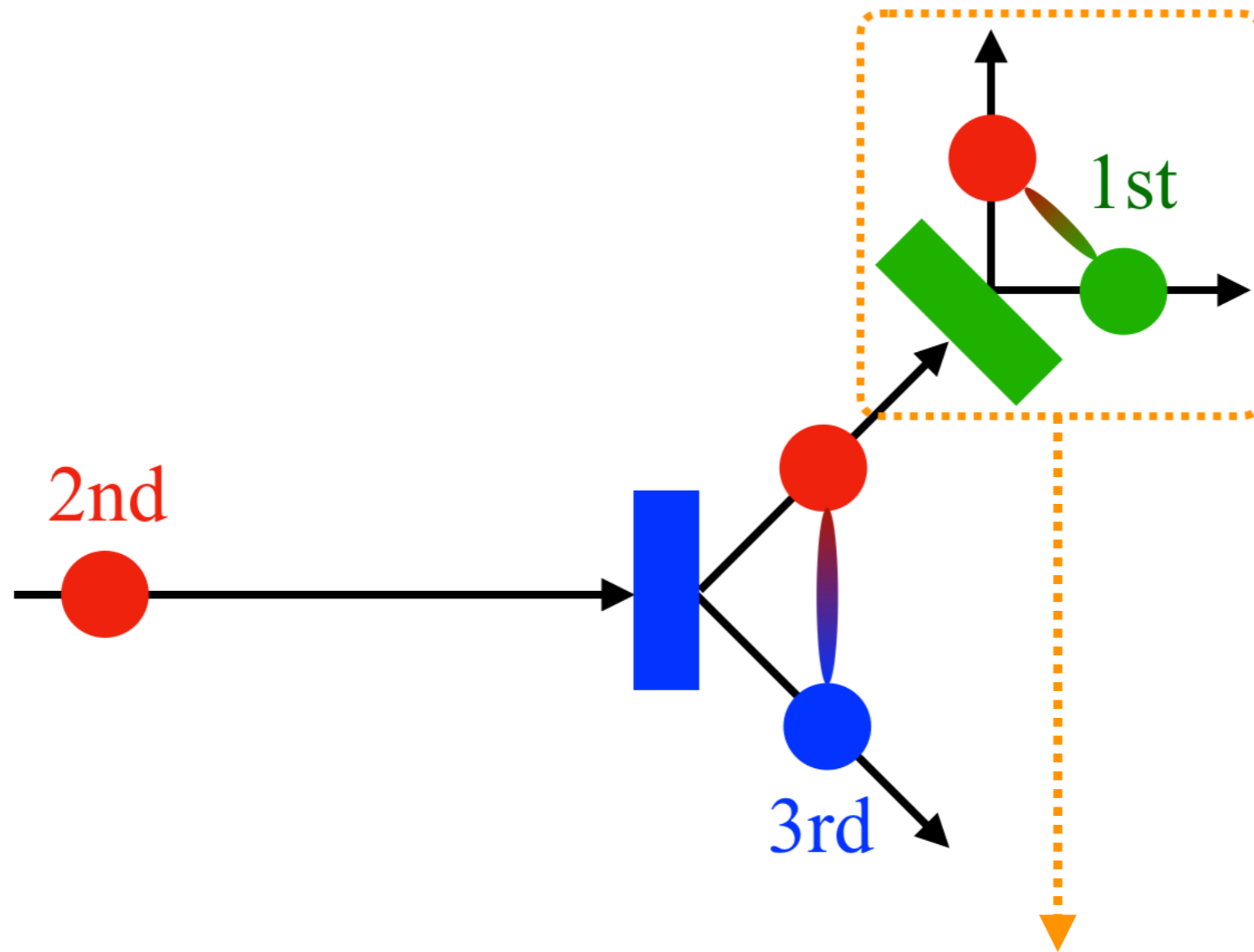

The second proton-proton scattering happens **probabilistically**. **NOT every 3rd proton** teleports **the unknown spin state**. **Classical information** is needed to help select the right events.

Towards spin teleportation between protons and antiprotons?

- Suppose a maximally spin-entangled proton-antiproton pair at the right energy

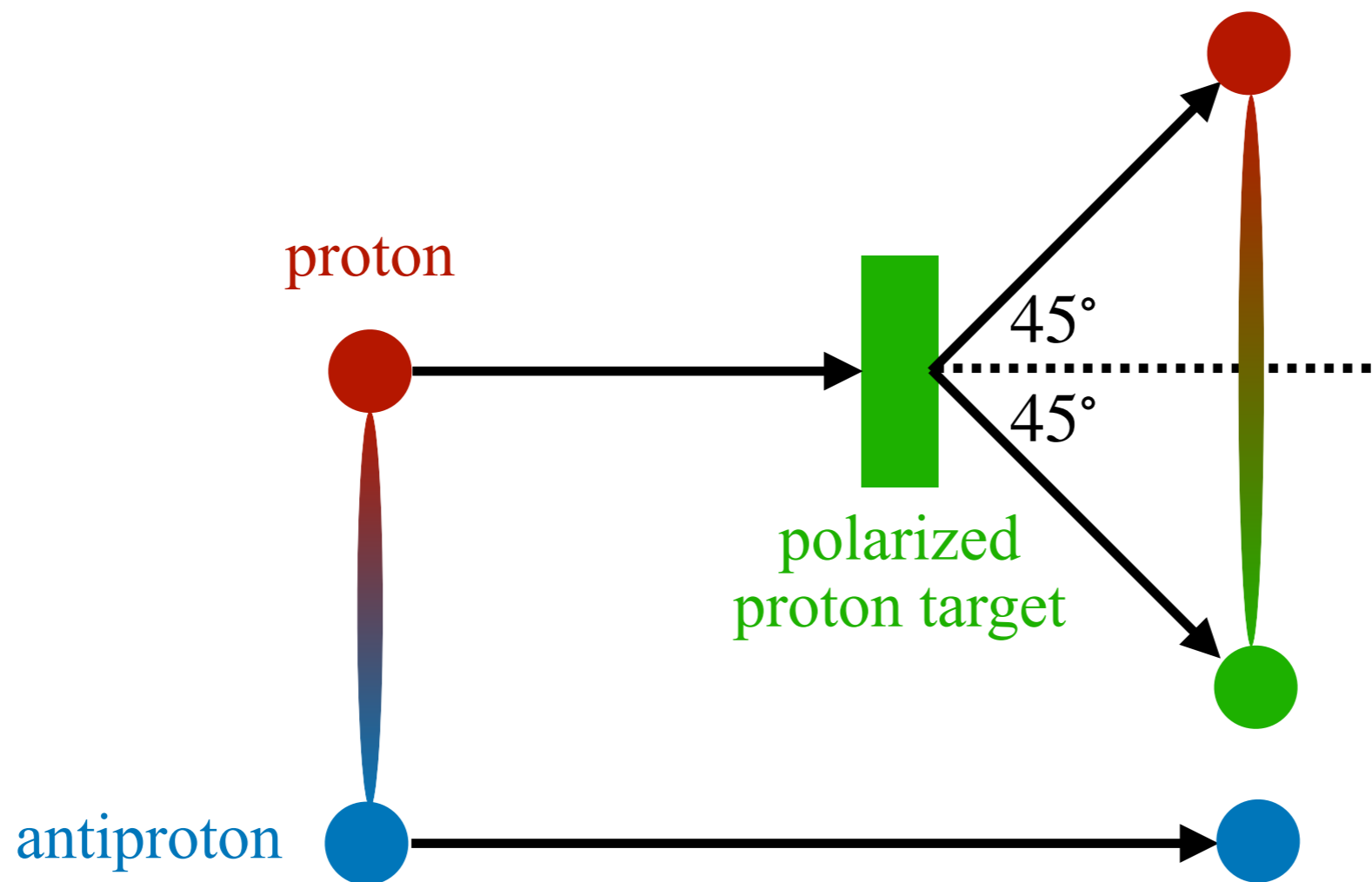

- Alternative to spin-filter approach for producing polarized antiproton?

Proposal for testing Bell transition operator

Led by **Furuno-san** and **Yassid**, approved by RCNP

RCNP EXPERIMENT E

PROPOSAL FOR EXPERIMENT AT RCNP

27 Feb 2026

TITLE:

Emergence of Strong Nuclear Entanglement by Proton-Proton Scattering

SPOKESPERSON:

Full Name	<u>Tatsuya Furuno</u>
Institution	<u>Department of Applied Physics, University of Fukui</u>
Title or Position	Senior Lecturer
Address	3-9-1 Bunkyo, Fukui, Fukui 910-8507, Japan
Phone number	+81-776-27-8656
E-mail	furuno@u-fukui.ac.jp

Full Name	<u>Yassid Ayyad</u>
Institution	<u>Universidad de Santiago de Compostela</u>
Title or Position	Researcher
Address	Rúa de Xoaquín Díaz de Rábago, s/n
Phone number	+34 881 814 033
E-mail	yassid.ayyad@usc.es

EXPERIMENTAL GROUP:

Name	Institution	Title or Position
D. Bai	Hohai University	Associate Professor
D. Bazin	FRIB, Michigan State University	Professor
D. Lee	FRIB, Michigan State University	Professor
W. Mittig	FRIB, Michigan State University	Professor
K. Kataguchi	Department of Applied Physics, University of Fukui	B4
T. Kawabata	Department of Physics, The University of Osaka	Professor
A. Sakaue	Department of Physics, The University of Osaka	Assistant Professor
Y. Honda	Department of Physics, The University of Osaka	D2
Y. Lin	Department of Physics, The University of Osaka	D1
S. Sakajo	Department of Physics, The University of Osaka	D1
S. Maesato	Department of Physics, The University of Osaka	M2
T. Okamura	Department of Physics, The University of Osaka	M2
H. Shimojo	Department of Physics, The University of Osaka	M2
R. Tanaka	Department of Physics, The University of Osaka	M1
S. Yamamoto	Department of Physics, The University of Osaka	M1
M. Yabumoto	Department of Physics, The University of Osaka	B4
T. Watanabe	Department of Physics, The University of Osaka	B4
Y. Matsuda	RCNP, The University of Osaka	Professor
E. Ideguchi	RCNP, The University of Osaka	Associate Professor
H. J. Ong	IMP, Chinese Academy of Science	Senior Researcher
D. T. Tran	Vietnam Academy of Science and Technology	Researcher
J. Zenihiro	Department of Physics, Kyoto University	Associate Professor
S. Okamoto	Department of Physics, Kyoto University	D3
M. Itoh	RARiS, Tohoku University	Professor
S. Adachi	RARiS, Tohoku University	Assistant Professor
H. Akimune	Department of Physics, Konan University	Professor

Conclusions

- Quantum teleportation for protons at MeV, making use of Bell projection and transition operators realized naturally in proton-proton scattering.
- Future directions:
 1. Numerical simulations of experimental details;
 2. Understanding quantum decoherence effects in detectors;
 3. Quantum teleportation between different species and across energy scales.
- Special thanks to
 - IGFAE:** Yassid Ayyad, Hector Alvarez-Pol, Youssef Khlifi
 - FRIB:** Wolfgang Mittig, Daniel Bazin, Dean Lee
 - Fukui U.:** Tatsuya Furuno
 - Fudan U.:** Zhaoxin Sheng, Haoyu Shang, Yugang Ma, Simin Wang, Zhicheng Xu

