

# Neural Quantum States for Simulating Hamiltonian Lattice Gauge Theories

Di Luo

Associate Professor  
Department of Physics  
Institute of Advanced Study  
Tsinghua University



清华大学 高等研究院  
Institute for Advanced Study, Tsinghua University

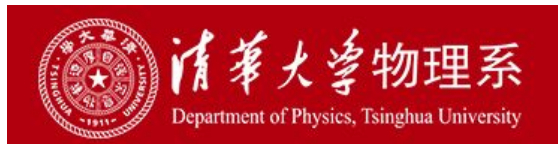

# Artificial Intelligence, Quantum Information and Physics

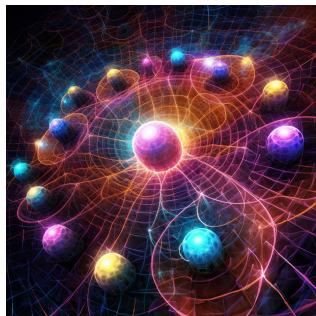

Many-body Physics

Particles in high dimensional phase space

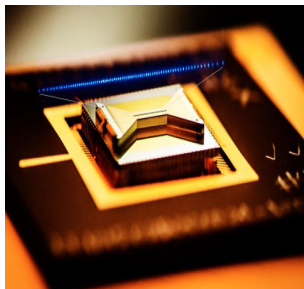

Quantum Information

Information in high dimensional wave function



Artificial Intelligence

Learning in high dimensional probability

**AI for Quantum**



**Quantum for AI**

# Motivations: Simulation of Quantum Field Theories

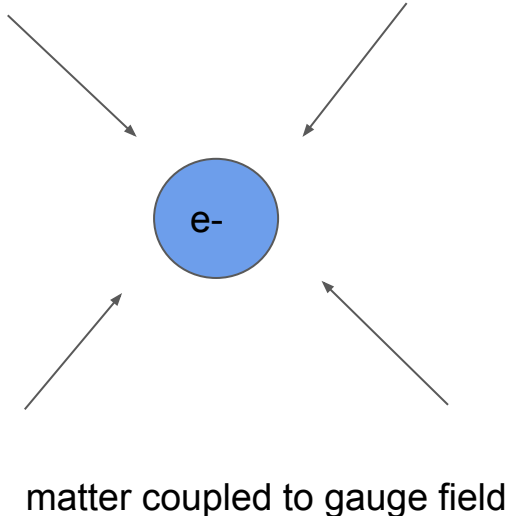

**Standard Model of Elementary Particles**

	three generations of matter (fermions)			interactions / force carriers (bosons)	
	I	II	III		
QUARKS	mass: 2.2 MeV/c <sup>2</sup> charge: 2/3 spin: 1/2 <b>u</b> up	mass: 1.26 GeV/c <sup>2</sup> charge: 2/3 spin: 1/2 <b>c</b> charm	mass: 173.1 GeV/c <sup>2</sup> charge: 2/3 spin: 1/2 <b>t</b> top	mass: 0 charge: 0 spin: 1 <b>g</b> gluon	mass: 124.07 GeV/c <sup>2</sup> charge: 0 spin: 0 <b>H</b> higgs
	mass: 4.7 MeV/c <sup>2</sup> charge: -1/3 spin: 1/2 <b>d</b> down	mass: 96 MeV/c <sup>2</sup> charge: -1/3 spin: 1/2 <b>s</b> strange	mass: 4.18 GeV/c <sup>2</sup> charge: -1/3 spin: 1/2 <b>b</b> bottom	mass: 0 charge: 0 spin: 1 <b>γ</b> photon	
	mass: 0.511 MeV/c <sup>2</sup> charge: -1 spin: 1/2 <b>e</b> electron	mass: 105.66 MeV/c <sup>2</sup> charge: -1 spin: 1/2 <b>μ</b> muon	mass: 1.7768 GeV/c <sup>2</sup> charge: -1 spin: 1/2 <b>τ</b> tau	mass: 81.19 GeV/c <sup>2</sup> charge: 0 spin: 1 <b>Z</b> Z boson	
LEPTONS	mass: 0 charge: 0 spin: 1/2 <b>ν<sub>e</sub></b> electron neutrino	mass: 0.17 MeV/c <sup>2</sup> charge: 0 spin: 1/2 <b>ν<sub>μ</sub></b> muon neutrino	mass: 1.8 MeV/c <sup>2</sup> charge: 0 spin: 1/2 <b>ν<sub>τ</sub></b> tau neutrino	mass: 80.433 GeV/c <sup>2</sup> charge: ±1 spin: 1 <b>W</b> W boson	

GAUGE BOSONS  
VECTOR BOSONS

SCALAR BOSONS

High energy

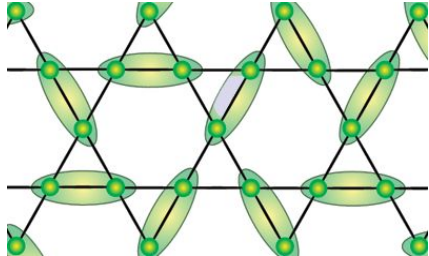

Condensed matter

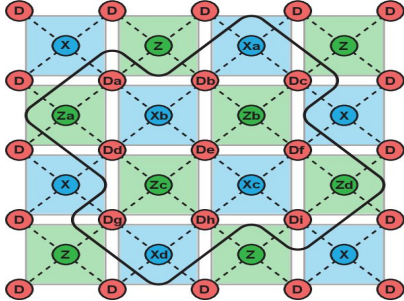

Quantum error correction

# Quantum Field Theories are Hard to Simulate

## Difficulties:

- **Gauge field:** infinite degree of freedom; gauge symmetries
- **Fermions:** sign problem; antisymmetric wave function

## Lagrangian formulation: challenges of sign problem

- Path integral Monte Carlo
- Flow based sampling method

## Hamiltonian formulation:

- Quantum computer: limited power at early stage
- Tensor networks: cannot include infinite degree of freedom
- Neural networks quantum state: new exploration

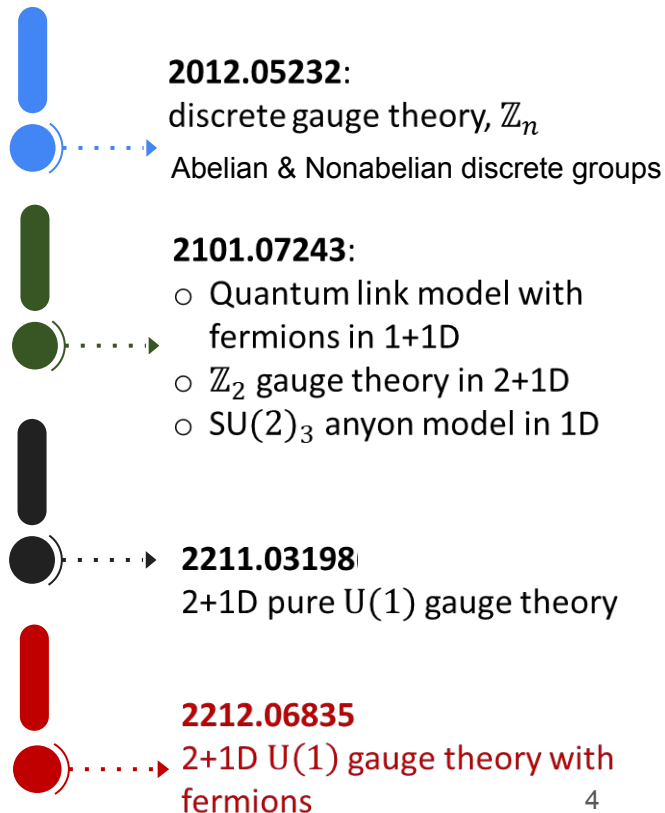

# Quantum Many-body Physics Simulation

Spectrum calculation

$$H|\psi\rangle = E|\psi\rangle$$

Eg. phase diagram, excited states,  
steady states

Real time evolution

$$H(t)|\psi(t)\rangle = i\hbar \frac{d}{dt} |\psi(t)\rangle$$

Eg. quantum chaos, quantum circuit  
simulation, dynamics of gauge theories

Challenges:

- Sign problem: non-positive real number / complex number
- high dimensionality: Hilbert space scales exponentially with particles

# Ongoing Efforts: Quantum Monte Carlo

*Quantum monte carlo: sample high dimension objects*

$$e^{-\tau H} |\psi\rangle \approx \prod^N (I - \frac{\tau}{N} H) |\psi\rangle$$



Transition probability with signs

- Draw samples according to  $|\psi|^2$ , apply transition probability kernel
- Due to sign problem, the relative variance of the sign scales exponentially

# Ongoing Efforts: Tensor Network

*Tensor network: tensor decomposition of high dimensional objects*

High rank tensor

$$T_{i,j,k,l} =$$

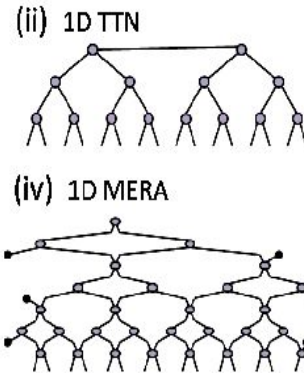
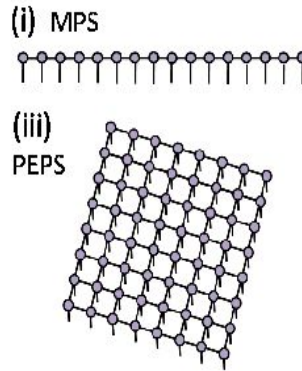

- Efficient for 1 dimensional system due to area law
- Challenges exist for two or three dimensional physics system

# Ongoing Efforts: Quantum Computation

*Quantum computation: naturally represents and operates on quantum objects*

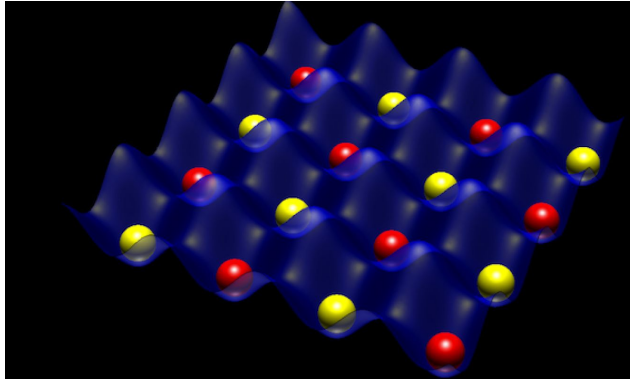

Analog quantum computation

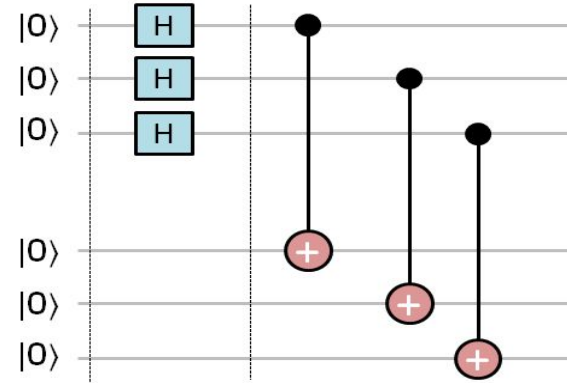

Digital quantum computation

- Natural for quantum dynamics, could be used for ground state problems
- Challenges exist under current technology

# New Exploration: Generative AI for Quantum Physics

For a  $n$  spin  $\frac{1}{2}$  particle or qubit system:

$$2^n \times 2^n \text{ hermitian matrix} \leftarrow H|\psi\rangle = E|\psi\rangle$$

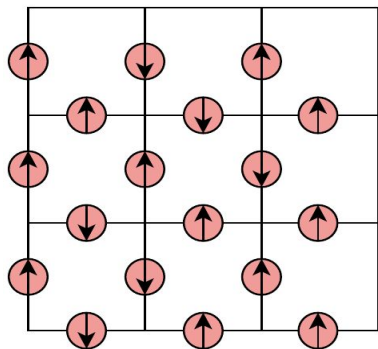

$2^n$  vector



Superposition of  $2^n$  configurations!

Q: Can machine learning help to find the best superposition of configurations?

# The Advancement of Generative AI

## Diffusion Model: MidJourney



## Large Video Model: Sora



Prompt: A stylish woman walks down a Tokyo street filled with warm glowing neon and animated city signage. She wears a black leather jacket, a long red dress, and black boots...

0:12 / 0:59

## Large Language Model: GPT

You

please predict the timeline that human realizes fault-tolerant quantum computation

ChatGPT

Predicting an exact timeline for achieving fault-tolerant quantum computation is speculative and depends on overcoming numerous theoretical and practical challenges. Based on the state of quantum computing research as of my last update in April 2023 and considering the pace of technological advancements, here's a cautiously optimistic forecast:

### Near-Term (Next 5-10 Years)

- **Incremental Progress:** Significant improvements in qubit coherence times, gate fidelities, and error correction codes. We might see the development and successful demonstration of small-scale error-corrected circuits, but these systems are unlikely to be fully fault-tolerant yet.

### Medium-Term (10-20 Years)

- **Prototypical Fault Tolerance:** Development of quantum systems that exhibit basic fault tolerance capabilities, capable of running simple quantum algorithms with error rates low enough to demonstrate a quantum advantage for specific tasks. This period will likely focus on refining

# New Exploration: Neural Network Quantum State

*Neural network: low dimensional representation of high dimensional objects*

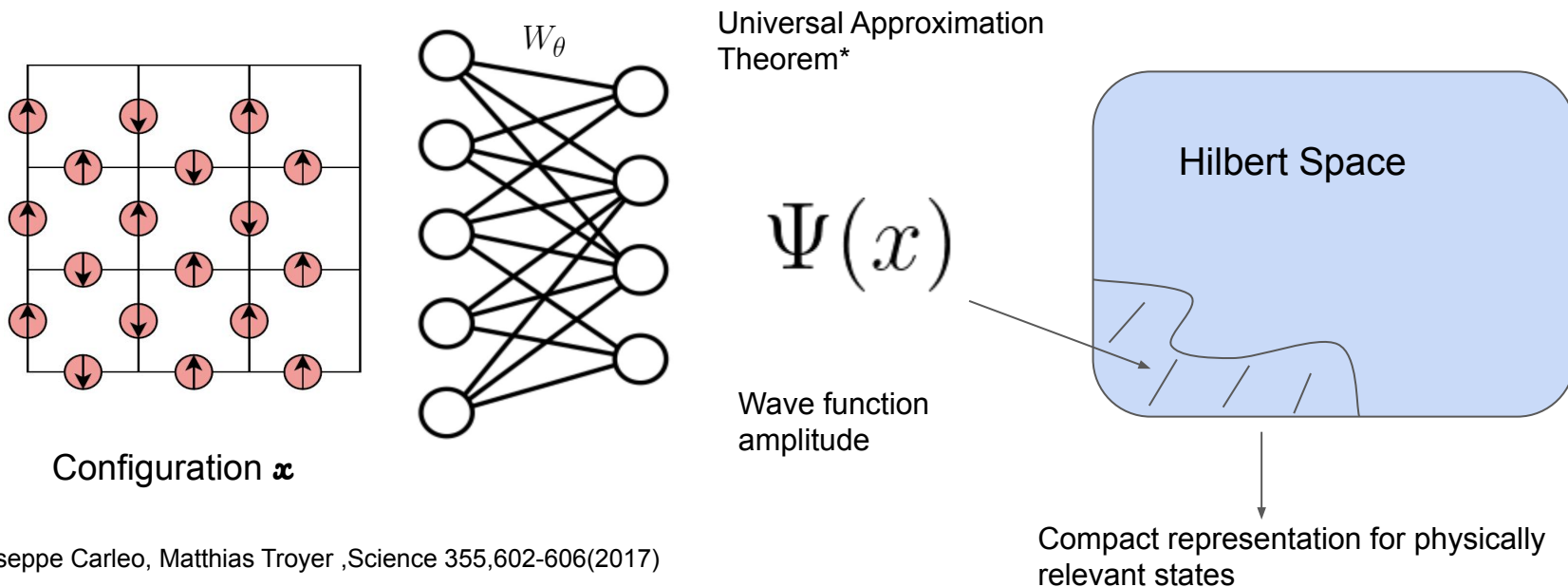

Giuseppe Carleo, Matthias Troyer, Science 355,602-606(2017)

\* The theorem holds for generic function in the infinite limit of the neural network representation

# Neural Quantum States

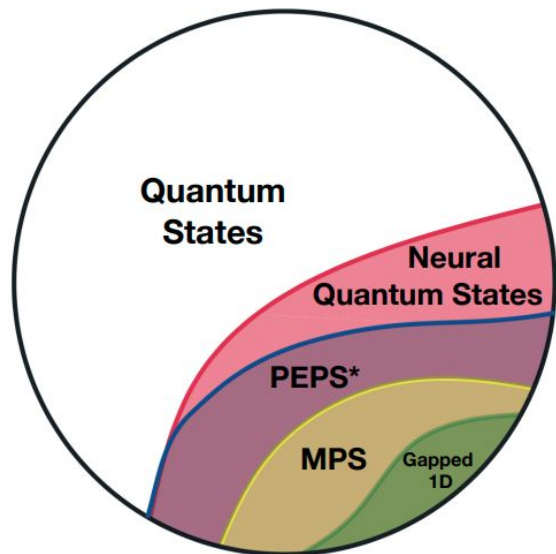

Or Sharir, Amnon Shashua, Giuseppe Carleo  
<https://arxiv.org/abs/2103.10293>

## Neural Network Quantum State:

- It is able to represent volume law state
- Exact representation for Jastrow, stabilizer states
- Variational simulation for theories with sign problems

# Neural Quantum States

## Infinite Neural Network Quantum State: Entanglement and Training Dynamics

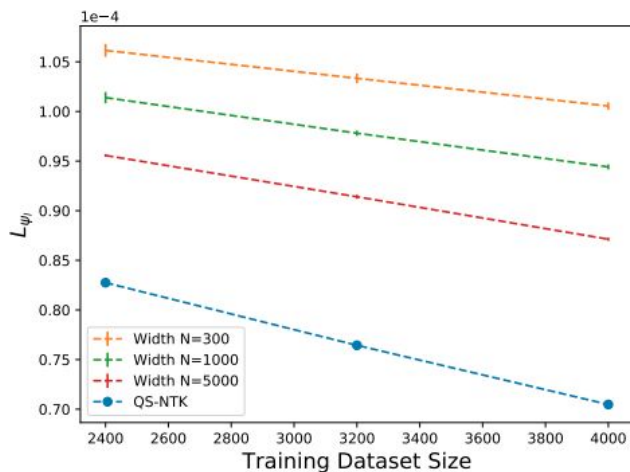

Quantum State Neural Tangent Kernel

**Theorem.** Quantum state supervised learning training is guaranteed to converge in infinite width limit.

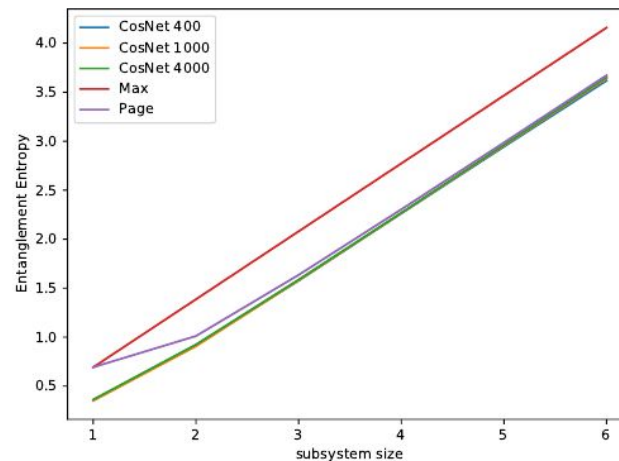

Volume law entanglement engineering of CosNet

# The Advancement of Generative AI

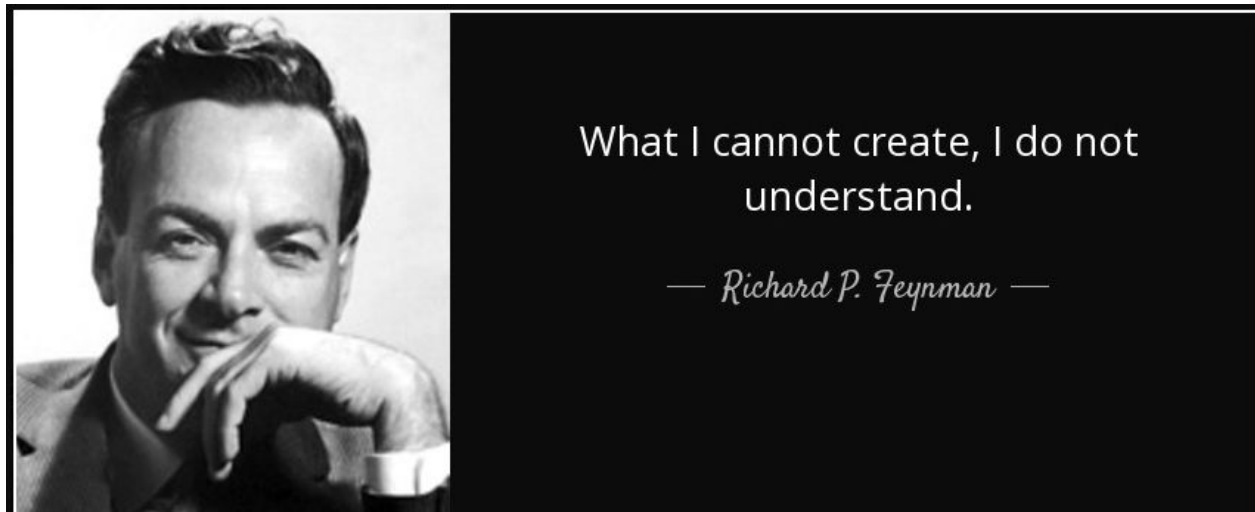

*Question: Can AI generate the quantum universe? If yes, base on what principles?*

*Symmetries and physics structure Matter*

# New Exploration: Neural Quantum States

- Gauge Equivariant Neural Network

(Phys. Rev. Lett. 127, 276402, arxiv. 2211.03198)

- Gauge-Fermion FlowNet for 2+1D QED at Finite Density

(Phys. Rev. Lett. 122, 226401, ,Phys. Rev. Research 5, 013216 arxiv.2212.06835)

- Neural Quantum Field State for continuum Quantum Field Theories

(Phys. Rev. Lett. 131, 081601)

# Motivations: Simulation of Quantum Field Theories

$\mathbb{Z}_2$  toric code model

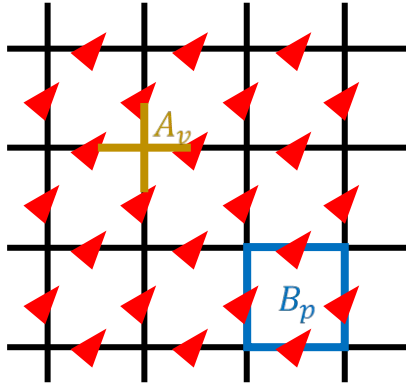

$\mathbb{Z}_2$  gauge theory  
 $A_v$ : Gauss's law

U(1) pure gauge theory

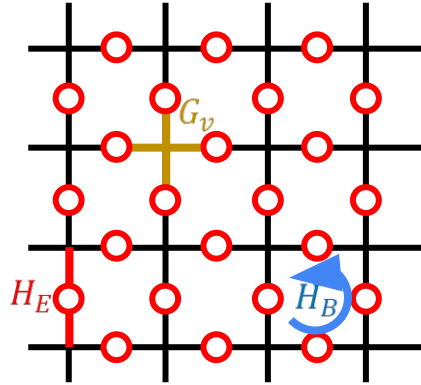

Continuous gauge theory  
Infinite degree of freedom

U(1) gauge theory with fermions

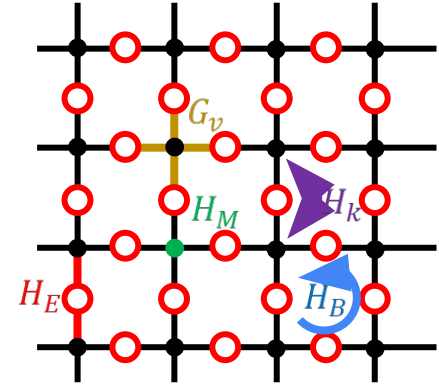

Gauge field fermion interaction  
Fermionic sign problem

# Gauge Equivariant Neural Network for Quantum Lattice Gauge Theories

- Develop gauge equivariant neural network for simulating quantum lattice gauge models
- Exact representation for Toric code, Kitaev  $D(G)$  model, Fracton ground states and applications to transverse field Toric code phase transition

$$\mathcal{H}_{\text{gauge}} = \{|\psi\rangle \in \mathcal{H} : G_v|\psi\rangle = |\psi\rangle \quad \forall v \in V\} \quad \psi(G_v x) = \psi(x)$$

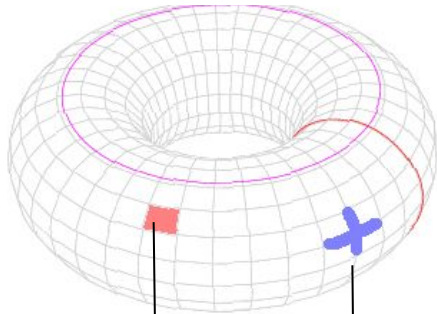

$$W_f := \prod_{e \in f} Z_e \quad G_v := \prod_{e \ni v} X_e$$

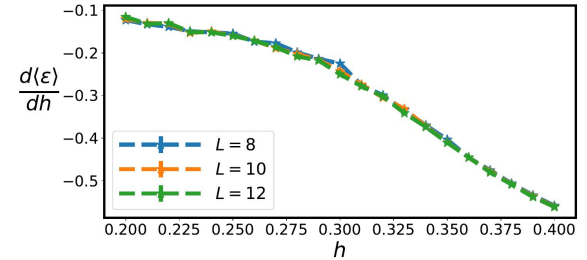
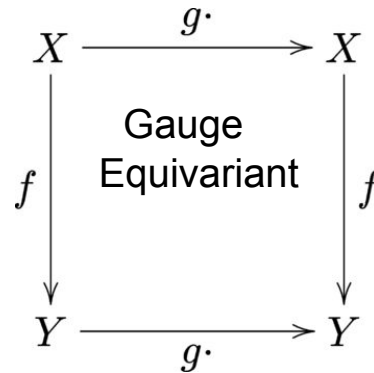

Perimeter law

Area law

# Gauge Equivariant Neural Quantum States

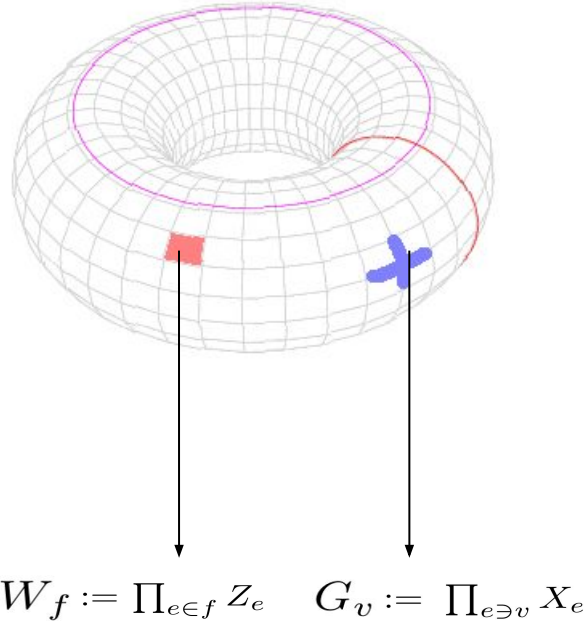

Toric code Hamiltonian  $\hat{H} = -J \sum_f W_f - \Delta \sum_{v \in V} G_v$

(AY Kitaev, 2003)

Gauge symmetry  $[G_v, \hat{H}] = 0$

$$\mathcal{H}_{\text{gauge}} = \{|\psi\rangle \in \mathcal{H} : G_v |\psi\rangle = |\psi\rangle \quad \forall v \in V\}$$

Q: How to construct neural network representation for wave functions with gauge symmetry?

$$\psi(G_v x) = \psi(x)$$

# Gauge Equivariant Neural Quantum States

- Invariant function

$$\psi(G_v x) = \psi(x)$$

- Equivariant function

$$f(x) = f_L \circ \cdots \circ f_1(x)$$

$$f_i(G_v x) = G_v f_i(x)$$

# Gauge Equivariant Neural Quantum States

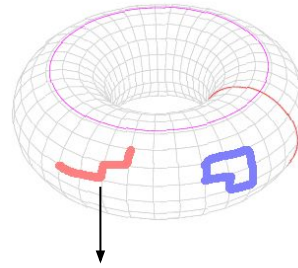
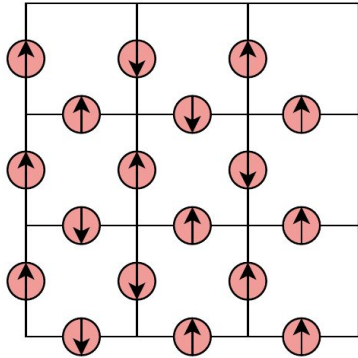
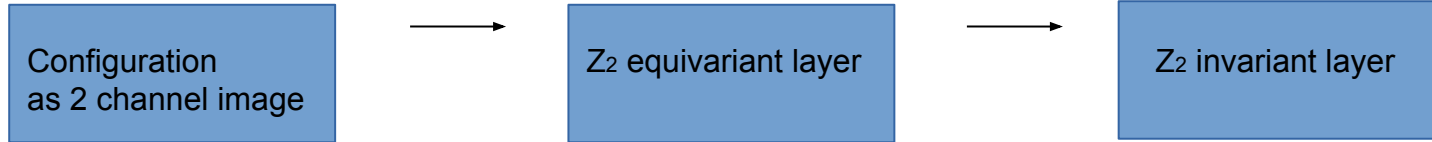

curve

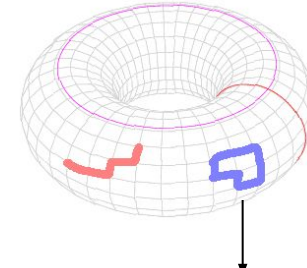

loop

# Gauge Equivariant Neural Quantum States

Study Area-law to Perimeter-law transition on Toric code with transverse field

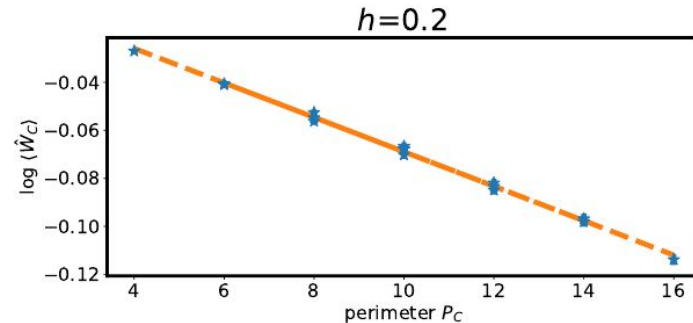
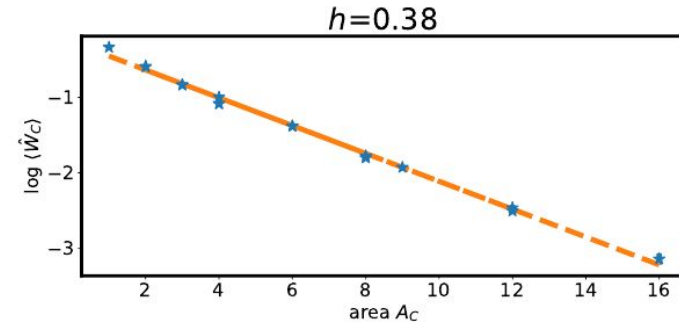
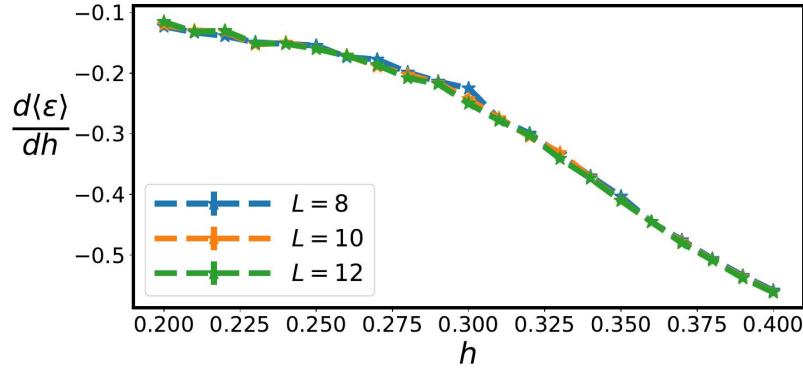

Order parameter:

$$\hat{W}_C := \prod_{e \in C} Z_e$$

Perimeter law

Area law

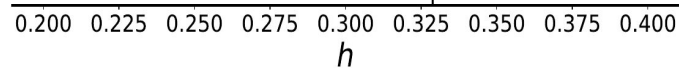

(J Vidal, et al. 2009)

# Gauge Equivariant Neural Quantum States

*Theorem.* There exists exact representation of the gauge equivariant neural network for ground states of the following models:

- 2D Toric code
- 3D Toric code
- Kitaev  $D(G)$  model with any discrete group  $G$
- X-cube Fracton

# Motivations: Simulation of Quantum Field Theories

$\mathbb{Z}_2$  toric code model

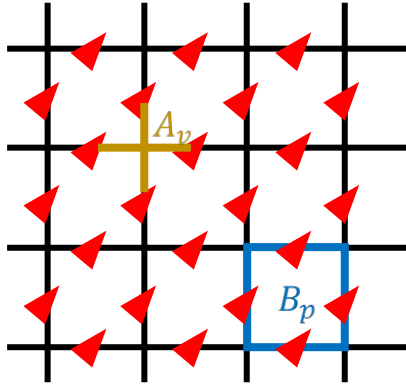

$\mathbb{Z}_2$  gauge theory  
 $A_v$ : Gauss's law

U(1) pure gauge theory

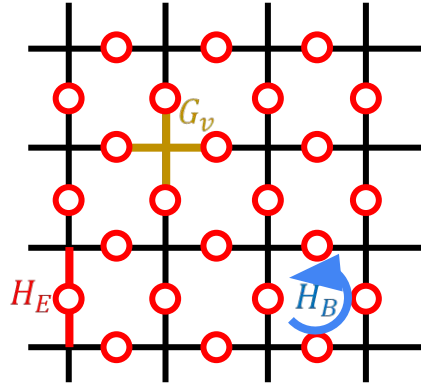

Continuous gauge theory  
Infinite degree of freedom

U(1) gauge theory with fermions

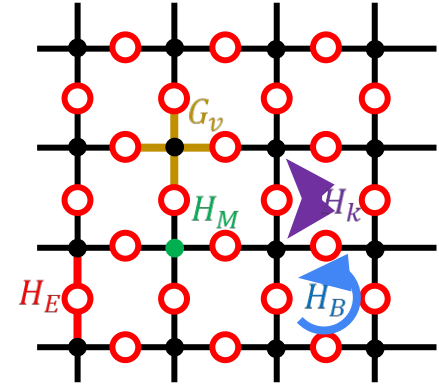

Gauge field fermion interaction  
Fermionic sign problem

# Gauge Equivariant Neural Network for 2+1D U(1) Gauge Theory Simulations in Hamiltonian Formulation

- Develop gauge equivariant neural network for simulating continuous-variable quantum lattice gauge models
- Comparable results in weak coupling regimes and improved performance in strong coupling regimes

$$\Psi(\dots, \theta_{v,\delta}, \dots) = \Psi(\dots, \theta_{v,\delta} + \alpha_{v+e_\delta} - \alpha_v, \dots)$$

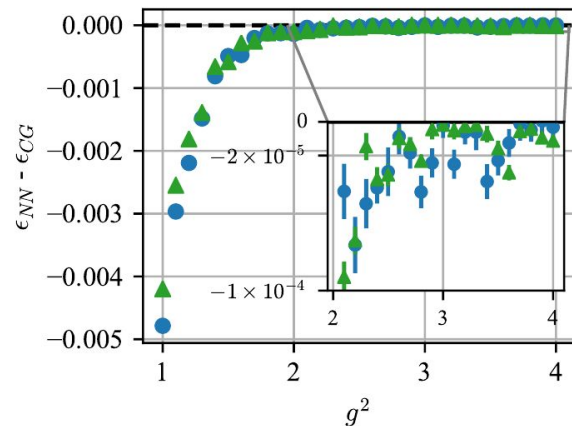
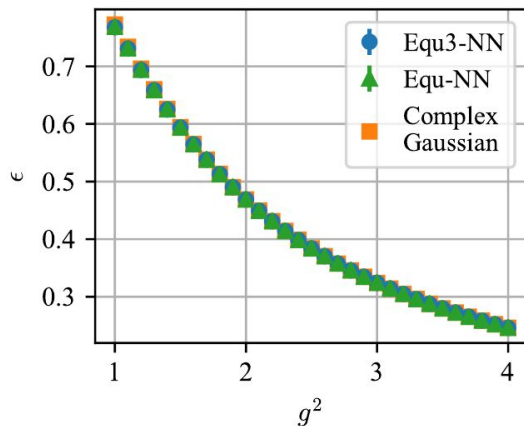
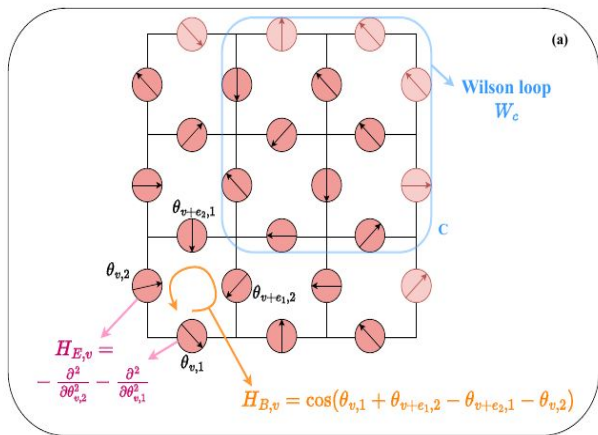

# Gauge Equivariant Neural Quantum States: 2+1D U(1) Theory

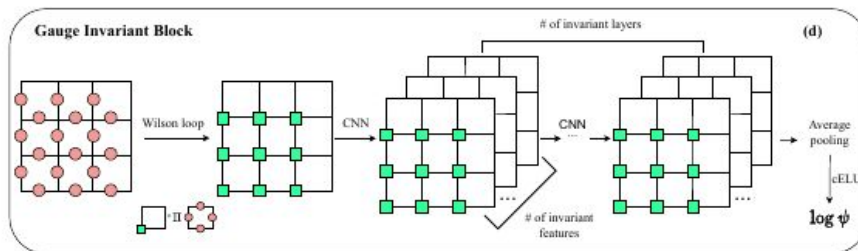
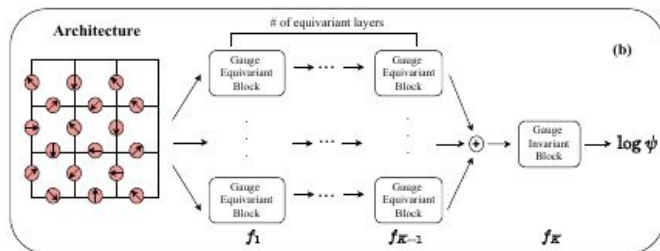
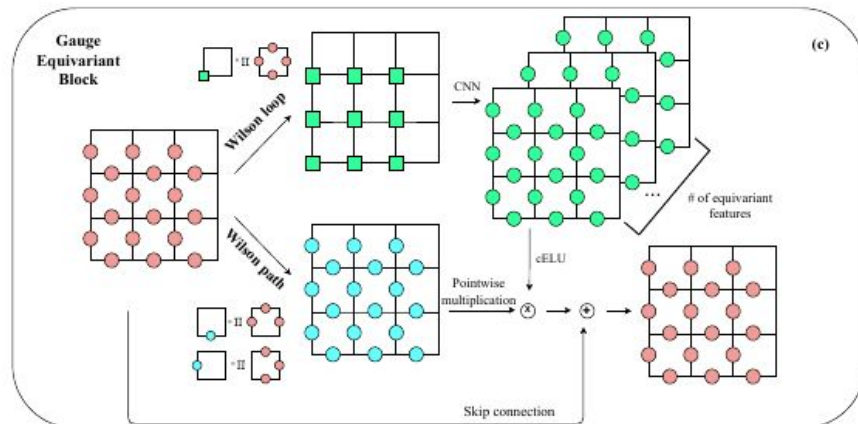
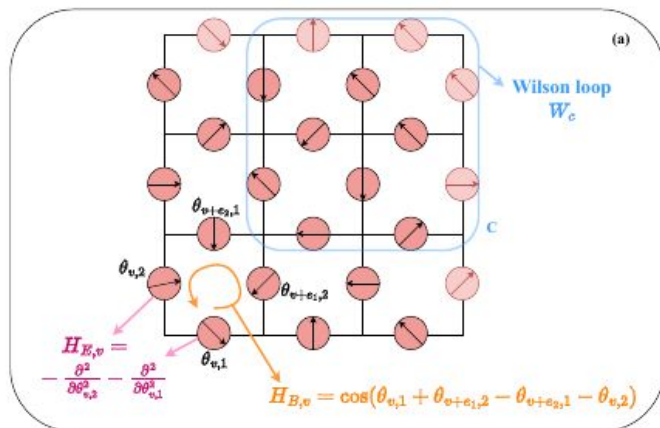

# Motivations: Simulation of Quantum Field Theories

$\mathbb{Z}_2$  toric code model

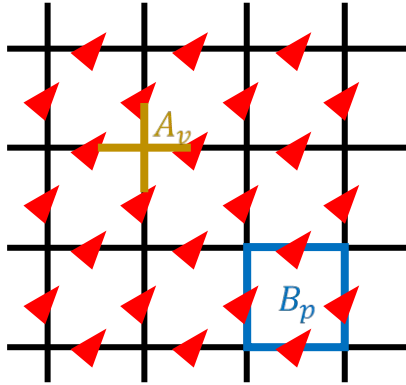

$\mathbb{Z}_2$  gauge theory  
 $A_v$ : Gauss's law

U(1) pure gauge theory

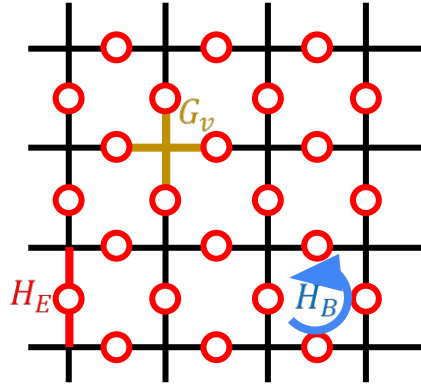

Continuous gauge theory  
 Infinite degree of freedom

U(1) gauge theory with fermions

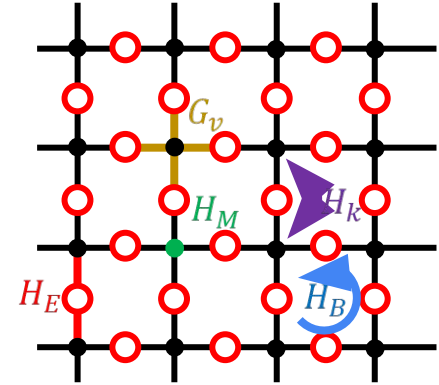

Gauge field fermion interaction  
 Fermionic sign problem

# Simulating 2+1D Lattice Quantum Electrodynamics at Finite Density with Neural Flow Wavefunctions

--- Develop Gauge-Fermion FlowNet, which represents  $U(1)$  gauge field without cutoff, obey Gauss's law, samples without auto-correlation time and variationally simulates model with sign problems.

--- Simulate 2+1D QED at finite density to study string breaking and confinement, charge crystal phase transition and magnetic phase transition.

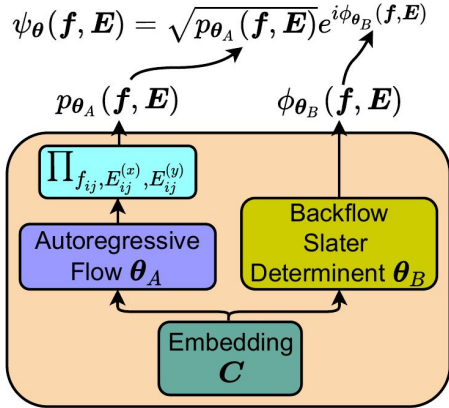

Gauge-Fermion FlowNet

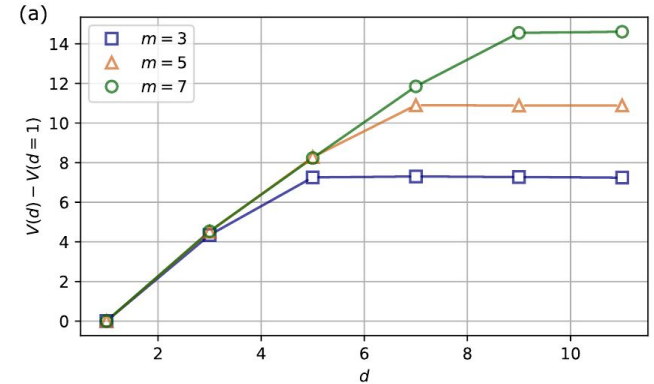
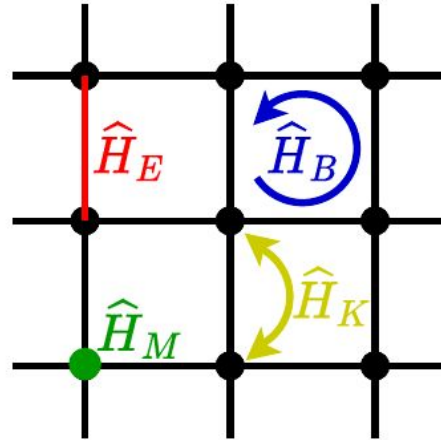

# Simulate 2+1D QED at Finite Density

PHYSICAL REVIEW X **10**, 041040 (2020)

---

## Two-Dimensional Quantum-Link Lattice Quantum Electrodynamics at Finite Density

Timo Felser<sup>1,2,3</sup>, Pietro Silvi<sup>4,5</sup>, Mario Collura<sup>1,2,6</sup> and Simone Montangero<sup>2,3</sup>

<sup>1</sup>*Theoretische Physik, Universität des Saarlandes, D-66123 Saarbrücken, Germany*

<sup>2</sup>*Dipartimento di Fisica e Astronomia "G. Galilei," Università di Padova, I-35131 Padova, Italy*

<sup>3</sup>*Istituto Nazionale di Fisica Nucleare (INFN), Sezione di Padova, I-35131 Padova, Italy*

<sup>4</sup>*Center for Quantum Physics, and Institute for Experimental Physics,  
University of Innsbruck, A-6020 Innsbruck, Austria*

<sup>5</sup>*Institute for Quantum Optics and Quantum Information,*

*Austrian Academy of Sciences, A-6020 Innsbruck, Austria*

<sup>6</sup>*SISSA-International School for Advanced Studies, I-34136 Trieste, Italy*

 (Received 13 January 2020; revised 13 July 2020; accepted 21 September 2020; published 25 November 2020)

We present an unconstrained tree-tensor-network approach to the study of lattice gauge theories in two spatial dimensions, showing how to perform numerical simulations of theories in the presence of fermionic matter and four-body magnetic terms, at zero and finite density, with periodic and open boundary conditions. We exploit the quantum-link representation of the gauge fields and demonstrate that a fermionic rishon representation of the quantum links allows us to efficiently handle the fermionic matter while finite densities are naturally enclosed in the tensor network description. We explicitly perform calculations for quantum electrodynamics in the spin-one quantum-link representation on lattice sizes of up to  $16 \times 16$  sites, detecting and characterizing different quantum regimes. In particular, at finite density, we detect signatures of a phase separation as a function of the bare mass values at different filling densities. The presented approach can be extended straightforwardly to three spatial dimensions.

DOI: [10.1103/PhysRevX.10.041040](https://doi.org/10.1103/PhysRevX.10.041040)

Subject Areas: Computational Physics,  
Particles and Fields, Quantum Physics

- Tensor network study on 2+1D quantum link model with spin 1 representation of gauge field

# Simulate 2+1D QED at Finite Density

PHYSICAL REVIEW X **9**, 021022 (2019)

## Monte Carlo Study of Lattice Compact Quantum Electrodynamics with Fermionic Matter: The Parent State of Quantum Phases

Xiao Yan Xu,<sup>1,\*</sup> Yang Qi,<sup>2,4,†</sup> Long Zhang,<sup>5</sup> Fakher F. Assaad,<sup>6</sup> Cenke Xu,<sup>7</sup> and Zi Yang Meng<sup>8,9,10,11,‡</sup>

<sup>1</sup>*Department of Physics, Hong Kong University of Science and Technology,  
Clear Water Bay, Hong Kong, China*

<sup>2</sup>*Center for Field Theory and Particle Physics, Department of Physics, Fudan University,  
Shanghai 200433, China*

<sup>3</sup>*State Key Laboratory of Surface Physics, Fudan University, Shanghai 200433, China*

<sup>4</sup>*Collaborative Innovation Center of Advanced Microstructures, Nanjing 210093, China*

<sup>5</sup>*Kavli Institute for Theoretical Sciences and CAS Center for Excellence in Topological Quantum  
Computation, University of Chinese Academy of Sciences, Beijing 100190, China*

<sup>6</sup>*Institut für Theoretische Physik und Astrophysik, Universität Würzburg, 97074, Würzburg, Germany*

<sup>7</sup>*Department of Physics, University of California, Santa Barbara, California 93106, USA*

<sup>8</sup>*Beijing National Laboratory for Condensed Matter Physics and Institute of Physics,  
Chinese Academy of Sciences, Beijing 100190, China*

<sup>9</sup>*Department of Physics, The University of Hong Kong, China*

<sup>10</sup>*CAS Center of Excellence in Topological Quantum Computation and School of Physical Sciences,  
University of Chinese Academy of Sciences, Beijing 100190, China*

<sup>11</sup>*Songshan Lake Materials Laboratory, Dongguan, Guangdong 523808, China*

 (Received 1 August 2018; revised manuscript received 19 March 2019; published 2 May 2019)

The interplay between lattice gauge theories and fermionic matter accounts for fundamental physical phenomena ranging from the deconfinement of quarks in particle physics to quantum spin liquid with fractionalized anyons and emergent gauge structures in condensed matter physics. However, except for certain limits (for instance, a large number of flavors of matter fields), analytical methods can provide few concrete results. Here we show that the problem of compact U(1) lattice gauge theory coupled to fermionic matter in (2 + 1)D is possible to access via sign-problem-free quantum Monte Carlo simulations. One can hence map out the phase diagram as a function of fermion flavors and the strength of gauge fluctuations. By increasing the coupling constant of the gauge field, gauge confinement in the form of various spontaneous-symmetry-breaking phases such as the valence-bond solid (VBS) and Néel antiferromagnet emerge. Deconfined phases with algebraic spin and VBS correlation functions are also observed. Such deconfined phases are incarnations of exotic states of matter, i.e., the algebraic spin liquid, which is generally viewed as the parent state of various quantum phases. The phase transitions between the deconfined and confined phases, as well as that between the different confined phases provide various manifestations of deconfined quantum criticality. In particular, for four flavors  $N_f = 4$ , our data suggest a continuous quantum phase transition between the VBS and Néel order. We also provide preliminary theoretical analysis for these quantum phase transitions.

- Monte Carlo study with even species of fermions without sign problem

# Simulate 2+1D QED at Finite Density

PRX QUANTUM 2, 030334 (2021)

Editors' Suggestion

## Simulating 2D Effects in Lattice Gauge Theories on a Quantum Computer

Danny Paulson<sup>1,2,†</sup>, Luca Dellantonio<sup>1,2,†</sup>, Jan F. Haase<sup>1,2,3,†</sup>, Alessio Celi<sup>4,5,6</sup>, Angus Kan<sup>1,2</sup>, Andrew Jena<sup>1,7</sup>, Christian Kokail<sup>5,6</sup>, Rick van Bijnen<sup>5,6</sup>, Karl Jansen<sup>8</sup>, Peter Zoller<sup>5,6</sup> and Christine A. Muschik<sup>1,2,9,\*</sup>

<sup>1</sup>*Institute for Quantum Computing, University of Waterloo, Waterloo, Ontario N2L 3G1, Canada*

<sup>2</sup>*Department of Physics and Astronomy, University of Waterloo, Waterloo, Ontario N2L 3G1, Canada*

<sup>3</sup>*Institute of Theoretical Physics and IQST, Universität Ulm, Albert-Einstein-Allee 11, Ulm D-89069, Germany*

<sup>4</sup>*Departament de Física, Universitat Autònoma de Barcelona, Bellaterra E-08193, Spain*

<sup>5</sup>*Center of Quantum Physics, University of Innsbruck, Innsbruck A-6020, Austria*

<sup>6</sup>*Institute for Quantum Optics and Quantum Information of the Austrian Academy of Sciences, Innsbruck A-6020, Austria*

<sup>7</sup>*Department of Combinatorics and Optimization, University of Waterloo, Waterloo, Ontario N2L 3G1, Canada*

<sup>8</sup>*NIC, DESY Zeuthen, Platanenallee 6, Zeuthen 15738, Germany*

<sup>9</sup>*Perimeter Institute for Theoretical Physics, Waterloo, Ontario N2L 2Y5, Canada*

 (Received 21 August 2020; accepted 4 August 2021; published 25 August 2021)

Quantum computing is in its greatest upswing, with so-called noisy-intermediate-scale-quantum devices heralding the computational power to be expected in the near future. While the field is progressing toward quantum advantage, quantum computers already have the potential to tackle classically intractable problems. Here, we consider gauge theories describing fundamental-particle interactions. On the way to their full-fledged quantum simulations, the challenge of limited resources on near-term quantum devices has to be overcome. We propose an experimental quantum simulation scheme to study ground-state properties in two-dimensional quantum electrodynamics (2D QED) using existing quantum technology. Our protocols can be adapted to larger lattices and offer the perspective to connect the lattice simulation to low-energy observable quantities, e.g., the hadron spectrum, in the continuum theory. By including both dynamical matter and a nonminimal gauge-field truncation, we provide the novel opportunity to observe 2D effects on present-day quantum hardware. More specifically, we present two variational-quantum-eigen-solver- (VQE) based protocols for the study of magnetic field effects and for taking an important first step toward computing the running coupling of QED. For both instances, we include variational quantum circuits for qubit-based hardware. We simulate the proposed VQE experiments classically to calculate the required measurement budget under realistic conditions. While this feasibility analysis is done for trapped ions, our approach can be directly adapted to other platforms. The techniques presented here, combined with advancements in quantum hardware, pave the way for reaching beyond the capabilities of classical simulations.

- Proposal on simulating 2+1D QED on quantum computer with gauge field cutoff
- Interesting phenomena on 1 plaquette

# 2+1D QED with Finite Density Dynamical Fermions

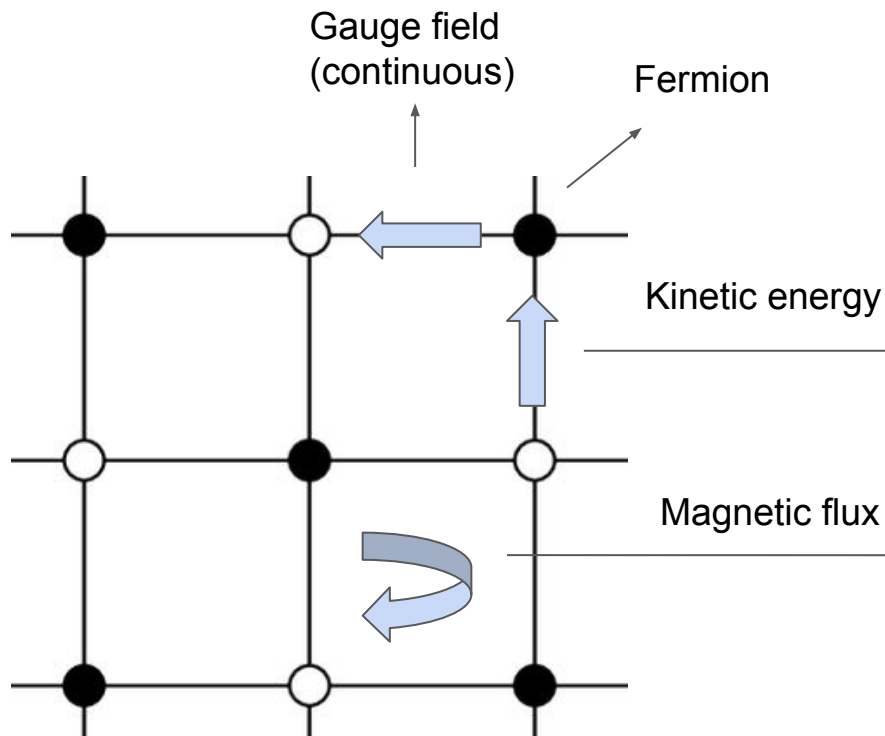

$$\hat{H} = \hat{H}_E + \hat{H}_B + \hat{H}_M + \hat{H}_K$$

$$\hat{H}_E = \frac{g_E^2}{2} \sum_{i,j} \left[ \left( \hat{E}_{i,j}^{(x)} \right)^2 + \left( \hat{E}_{i,j}^{(y)} \right)^2 \right]$$

$$\hat{H}_B = -\frac{g_B^2}{2} \sum_{i,j} \left( \hat{P}_{i,j} + \hat{P}_{i,j}^\dagger \right)$$

$$\hat{P}_{i,j} = \hat{U}_{i,j}^{(x)} \hat{U}_{i+1,j}^{(y)} \left( \hat{U}_{i,j+1}^{(x)} \right)^\dagger \left( \hat{U}_{i,j}^{(y)} \right)^\dagger.$$

$$[\hat{E}_{i,j}^{(w)}, \hat{U}_{i',j'}^{(w')}] = -\delta_{i,i'} \delta_{j,j'} \delta_{w,w'} \hat{U}_{i',j'}^{(w')}$$

# 2+1D QED with Finite Density Dynamical Fermions

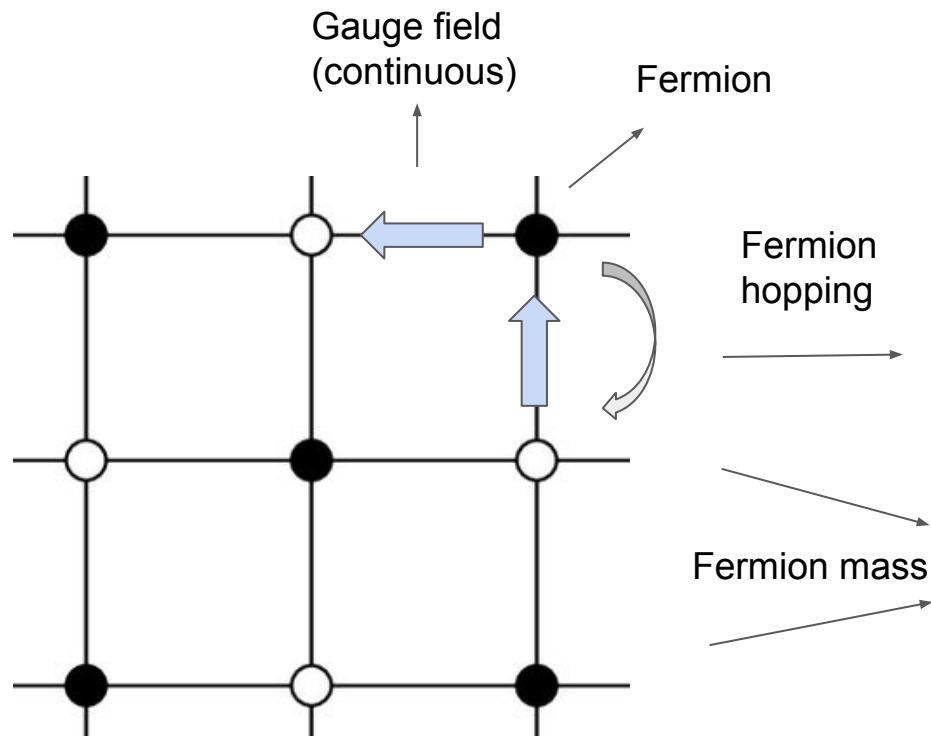

$$\hat{H} = \hat{H}_E + \hat{H}_B + \hat{H}_M + \hat{H}_K$$

$$\hat{H}_K = -\kappa \sum_{i,j} \left[ \hat{\psi}_{i,j}^\dagger \left( \hat{U}_{i,j}^{(x)} \right)^\dagger \hat{\psi}_{i+1,j} + \hat{\psi}_{i,j}^\dagger \left( \hat{U}_{i,j}^{(y)} \right)^\dagger \hat{\psi}_{i,j+1} + \text{H.C.} \right]$$

$$\hat{H}_M = m \sum_{i,j} \left\{ \frac{1}{2} [(-1)^{i+j} + 1] \hat{\psi}_{i,j}^\dagger \hat{\psi}_{i,j} - \frac{1}{2} [(-1)^{i+j} - 1] \hat{\psi}_{i,j} \hat{\psi}_{i,j}^\dagger \right\},$$

# 2+1D QED with Finite Density Dynamical Fermions

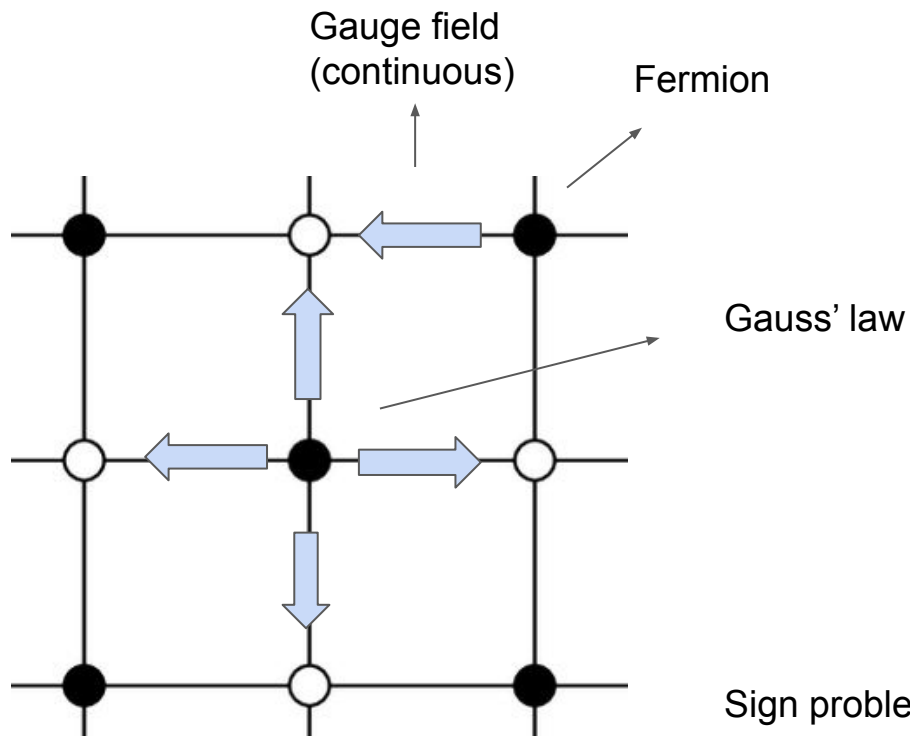

$$\hat{H} = \hat{H}_E + \hat{H}_B + \hat{H}_M + \hat{H}_K$$

$$\hat{E}_{i,j}^{(x)} + \hat{E}_{i,j}^{(y)} - \hat{E}_{i-1,j}^{(x)} - \hat{E}_{i,j-1}^{(y)} = \hat{q}_{i,j} \quad \forall(i,j)$$

$$\hat{q}_{i,j} = \hat{\psi}_{i,j}^\dagger \hat{\psi}_{i,j} + \frac{1}{2} [(-1)^{i+j} - 1]$$

Sign problem exist even for zero density



# 2+1D QED with Finite Density Dynamical Fermions

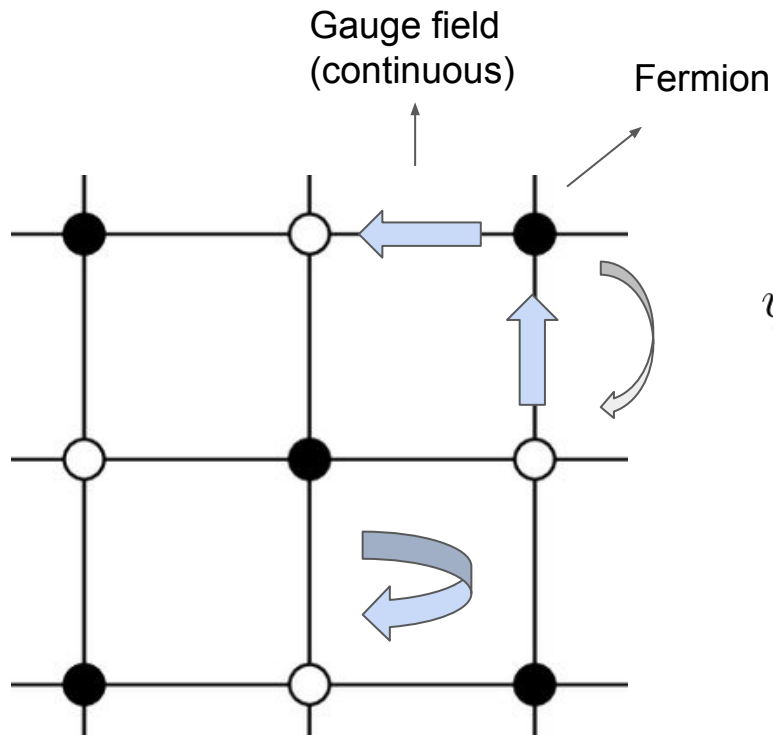

$$\hat{H} = \hat{H}_E + \hat{H}_B + \hat{H}_M + \hat{H}_K$$

$$\psi(f, E) = \psi_{density}(f, E)\psi_{backflow}(f, E)$$

## 1. Neural network backflow:

- fermionic anti-symmetry and sign problems

## 2. Gauge invariant autoregressive network:

- Sample without auto-correlation time
- Enforce gauge symmetry with fermions

## 3. Discrete Flow-based model:

- U(1) degree without cut-off

# Backflow Transformations via Neural Networks for Quantum Many-Body Wave-Functions

--- Develop anti-symmetry neural network for fermionic simulations

$$\Psi(\dots, x_i, \dots, x_j, \dots) = -\Psi(\dots, x_j, \dots, x_i, \dots)$$

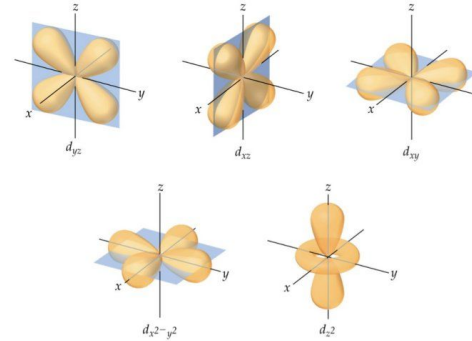
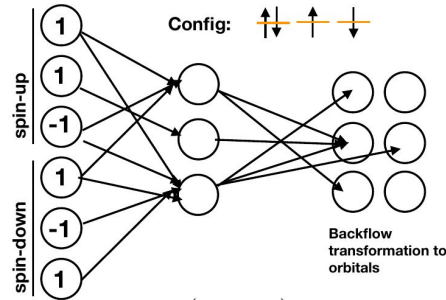

# Neural Network Backflow: Fermionic Neural Network Quantum State

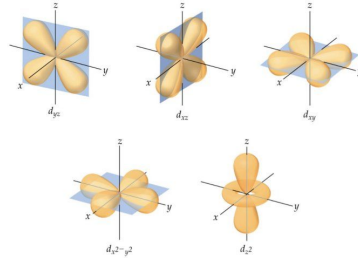
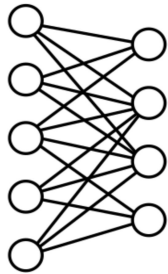
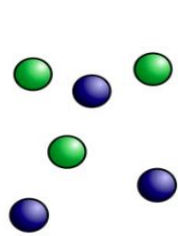

$$\det \left[ \begin{array}{ccc} \text{orbital } d_{xy} & \text{orbital } d_{xz} & \text{orbital } d_{yz} \\ \text{orbital } d_{x^2-y^2} & \text{orbital } d_{z^2} & \text{orbital } d_{yz} \end{array} \right]$$

$$\Psi(\mathbf{r}) = \det([\phi_{k\sigma}^b(r_{i,\sigma}; \mathbf{r})])$$

Particles  
Configuration  $\mathbf{r}$

$$\phi_{k\sigma}^b(r_{i,\sigma}; \mathbf{r}) = \phi_{k\sigma}(r_{i,\sigma}) + a_{ki,\sigma}^{NN}(\mathbf{r})$$



Mean field orbital



Neural network backflow  
transformation

- Configuration dependent many-particle orbital
- Anti-symmetry neural network to change nodal surface and density
- Generalization to arbitrary lattice and continuum system



Backflow on liquid helium  
*Phys. Rev.* 102, 1189

# Neural Network Backflow: Fermionic Neural Network Quantum State

- Anti-symmetric neural network
- Change sign structure directly and generalization to arbitrary lattices
- Theoretically exact and generalization of Slater-Jastrow-Backflow hierarchy
- Further advancement in quantum chemistry: FermiNet (DeepMind), PauliNet

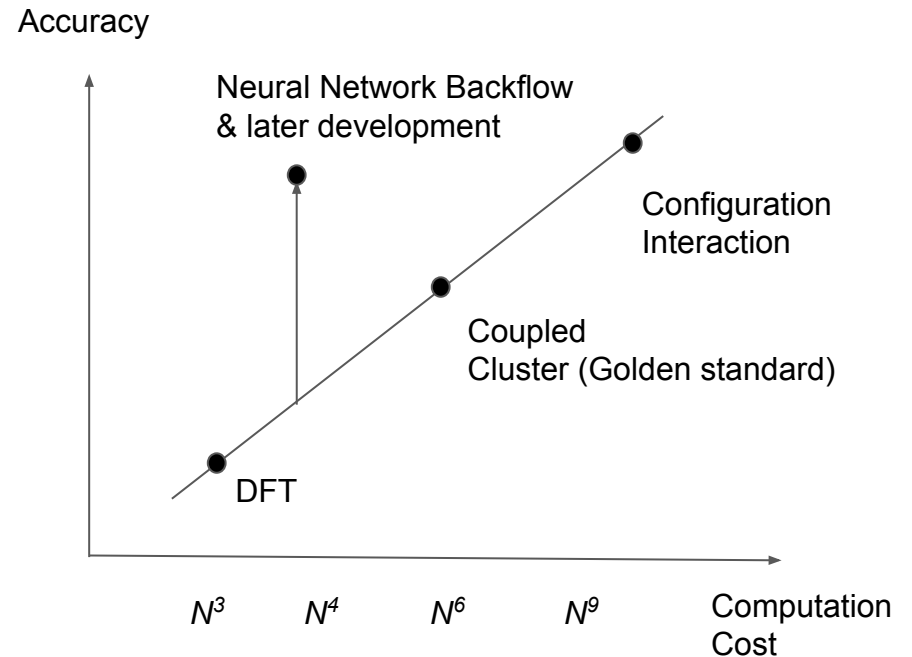

David Pfau, et al, *Phys. Rev. Research* 2, 033429 (2020)

J Hermann, et al, *Nature Chemistry* volume 12, pages891–897 (2020)

# Neural Network Backflow: Fermionic Neural Network Quantum State

Many-body Neural Bloch Wavefunction

moiré atom

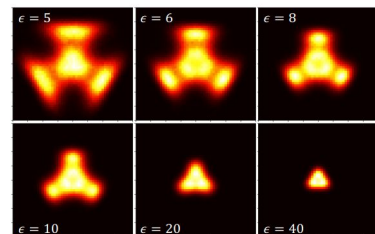
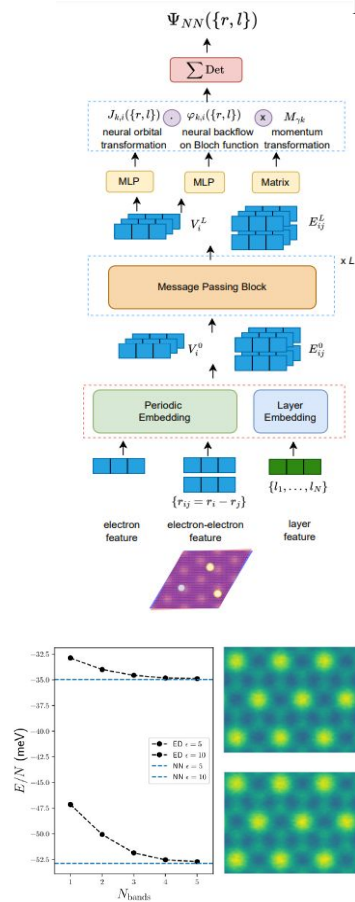

Ground state charge density of 6-electron moiré atom at several interaction strengths, showing the evolution from Wigner molecule at small  $\epsilon$  to Schrödinger atom at large  $\epsilon$ . ( $\phi = 30^\circ$ ,  $V = 20\text{meV}$ ,  $a_M = 15\text{nm}$ ,  $m = 1m_e$ )

moiré solid: generalized wigner crystal

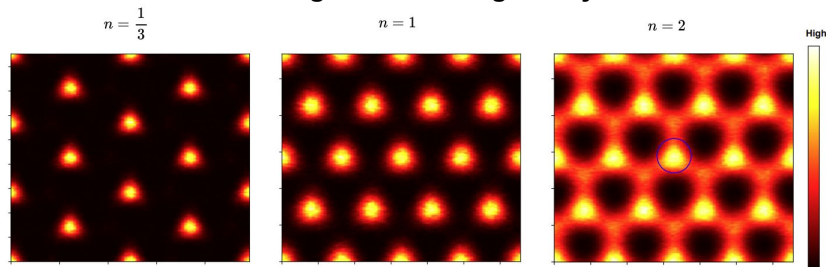

Charge density of  $\text{WSe}_2/\text{WS}_2$  with  $V = 15 \text{ meV}$ ,  $a_M = 8.2 \text{ nm}$ ,  $m^* = 0.5m_e$ ,  $\phi = 45^\circ$  at fillings  $n = \frac{1}{3}, 1, 2$ .

Fractional Chern Insulator

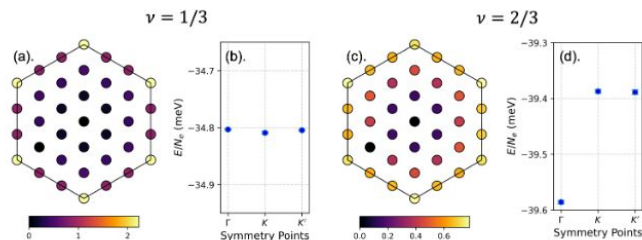

outperform state-of-the-arts multi-band ED

Exciton superconductivity and superfluid

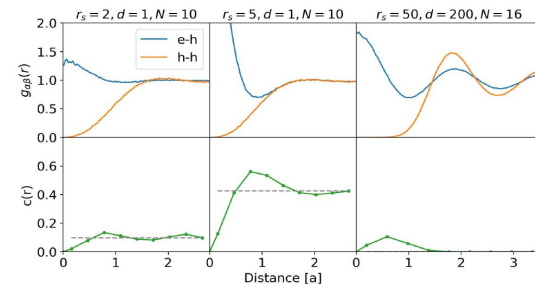

arxiv. 2303.08162, 2311.02143, 2406.17645, 2503.13585



# Gauge Invariant and Anyonic Symmetric Autoregressive Neural Network for Quantum Lattice Models

--- Develop autoregressive neural network that satisfies gauge constraints and algebraic constraints with applications to quantum link models, toric codes, Fracton, anyonic models

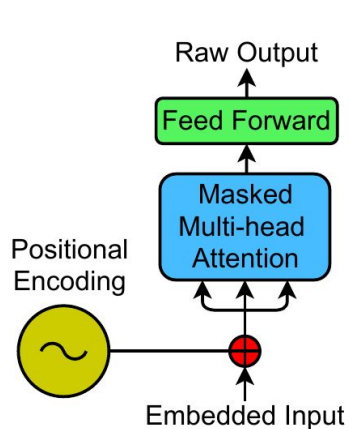

Transformer Autoregressive Wave function

$$f(x_1, x_2, \dots, x_n) = \prod_i^n f(x_i | x_{i <})$$

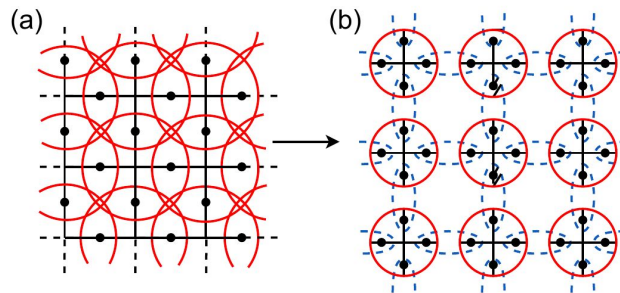

Symmetry via Composite Particles

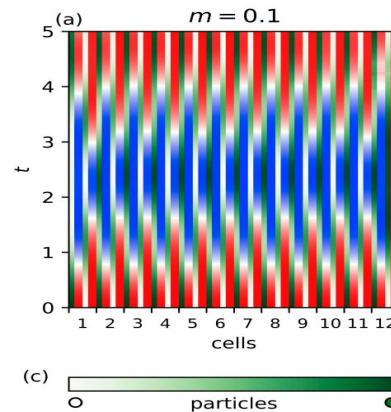

# Gauge Invariant and Anyonic Symmetric Autoregressive Neural Network

Autoregressive neural network with gauge symmetry or Anyonic symmetry

$$f(x_1, x_2, \dots, x_n) = \prod_i^n f(x_i | x_{i <})$$

- Exact sampling, which is more efficient than Markov Chain Monte Carlo
- It could be constructed to obey gauge symmetries or other algebraic constraint

# Gauge Invariant and Anyonic Symmetric Autoregressive Neural Network

Applications to 2D, 3D Toric code and X-cube Fracton model

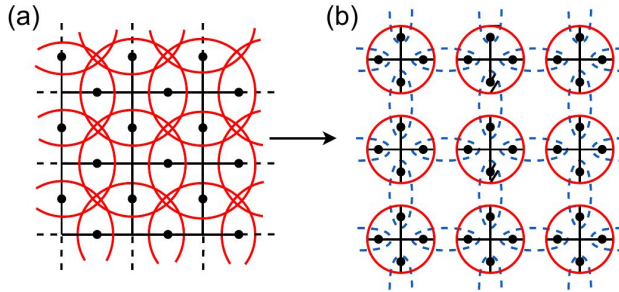

2D toric code

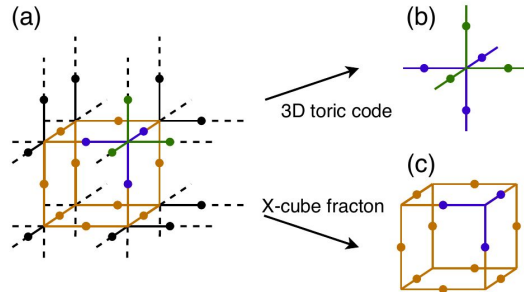

3D toric code

X-cube fracton

Exact representation of grounds states and excited states for:

- 2D Toric code
- 3D Toric code
- X-cube Fracton

# Gauge Invariant and Anyonic Symmetric Autoregressive Neural Network

## SU(2)<sub>3</sub> Fibonacci anyons

$$\tau \otimes \tau = \tau \oplus \mathbb{1}, \tau \otimes \mathbb{1} = \mathbb{1} \otimes \tau = \tau$$

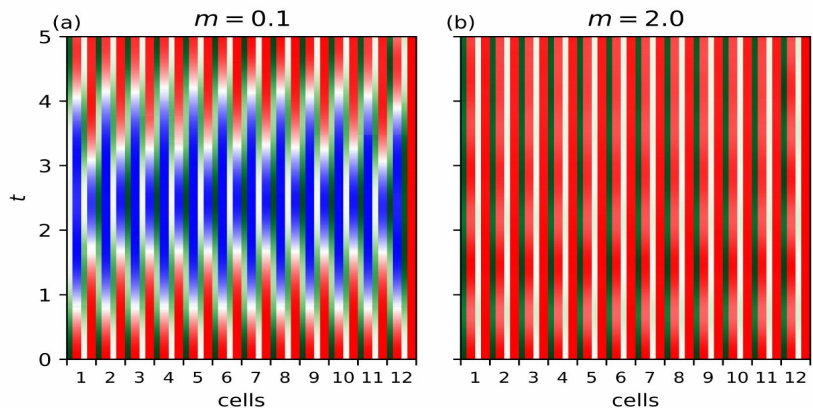

String inversion of real-time dynamics in 1+1D Quantum Link Model

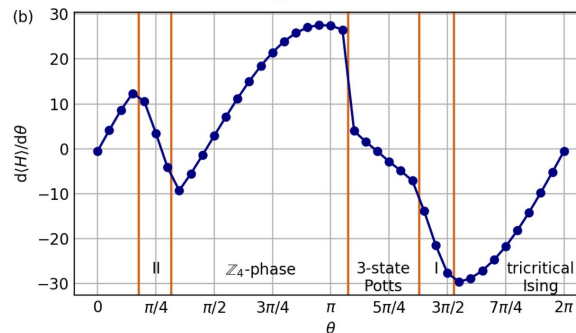

Phase diagram

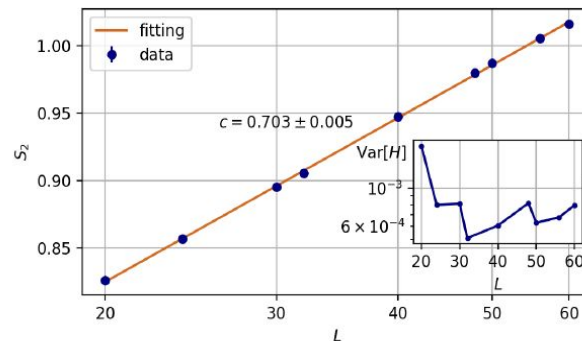

Central charge

# 2+1D QED with Finite Density Dynamical Fermions

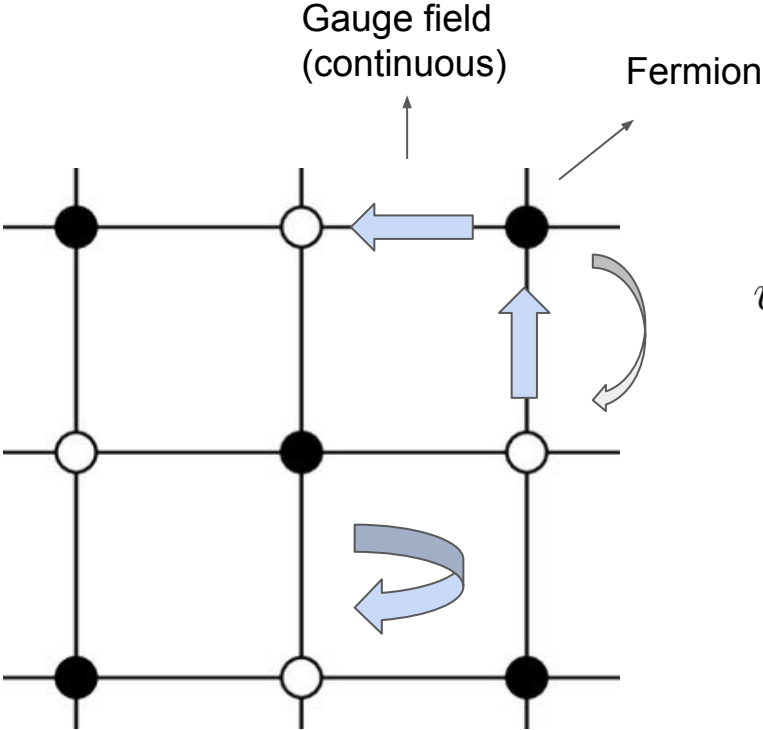

$$\hat{H} = \hat{H}_E + \hat{H}_B + \hat{H}_M + \hat{H}_K$$

$$\psi(f, E) = \psi_{density}(f, E)\psi_{backflow}(f, E)$$

1. Neural network backflow:
  - fermionic anti-symmetry and sign problems
2. Gauge invariant autoregressive network:
  - Sample without auto-correlation time
  - Enforce gauge symmetry with fermions
3. Discrete Flow-based model:
  - U(1) degree without cut-off

# Flow-based Model

## Continuous Flow

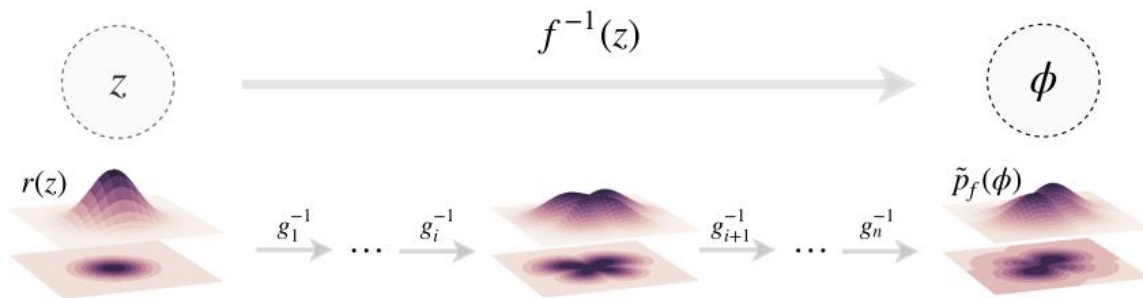

(a) Normalizing flow between prior and output distributions

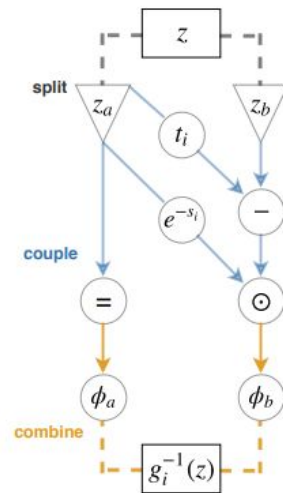

- M. S. Albergo, G. Kanwar, P. E. Shanahan, PRD 100 (3), 034515
- G Kanwar, etc, P.E. Shanahan, PRL 125 (12), 121601

# QFlow: Generative Modeling for Differential Equations of Open Quantum Dynamics with Normalizing Flows

--- Develop flow-based models with  $Q$  function for continuous variable open quantum dynamics simulations using stochastic Euler methods and time dependent variational principle

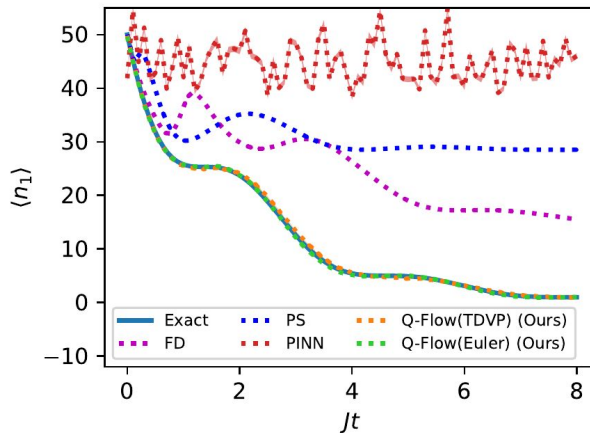
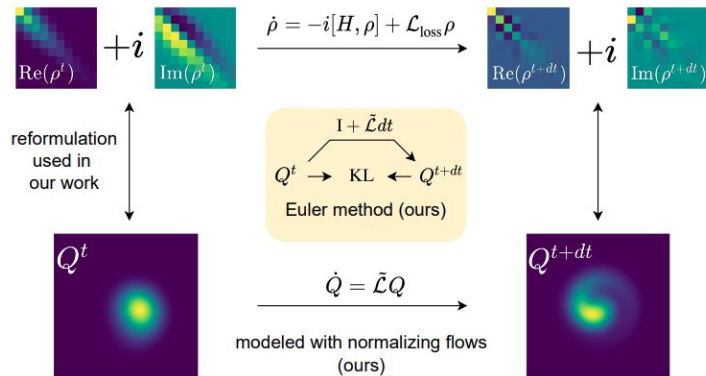

# Discretized Flow-based Model

Discretized Flow: represent U(1) degree freedom in  $E$  basis without cutoff

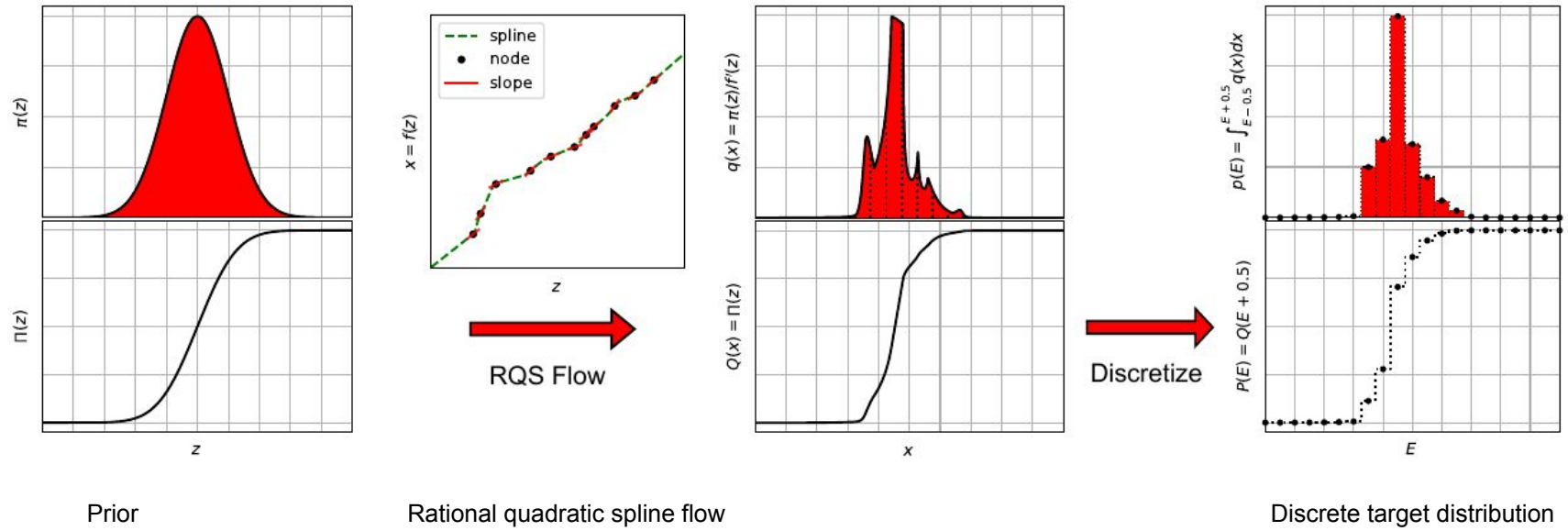

# Simulate 2+1D QED at Finite Density: Gauge-Fermion FlowNet

Impose Gauss'law,  
U(1) freedom without cutoff,  
Exact sampling

Fermionic anti-symmetry

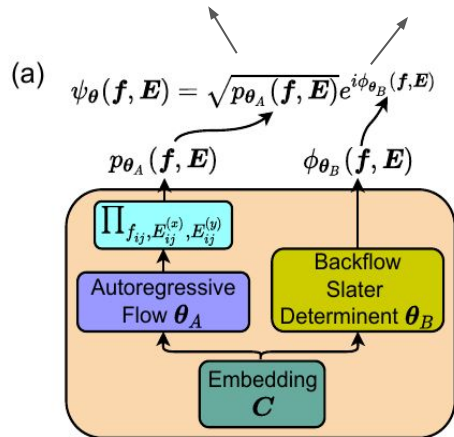

Gauge-Fermion FlowNet

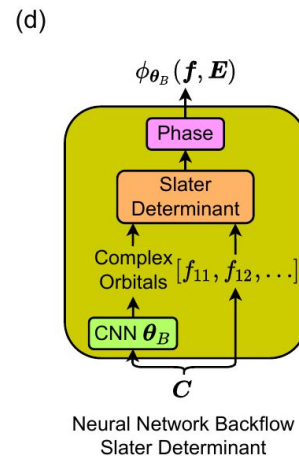
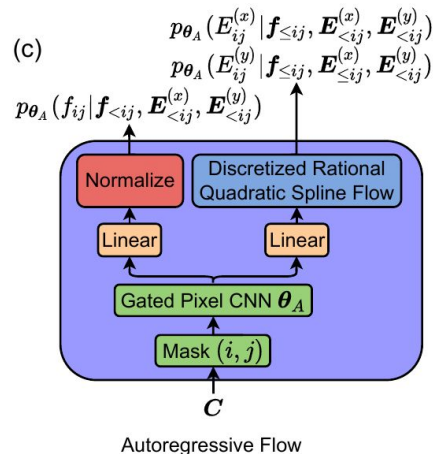
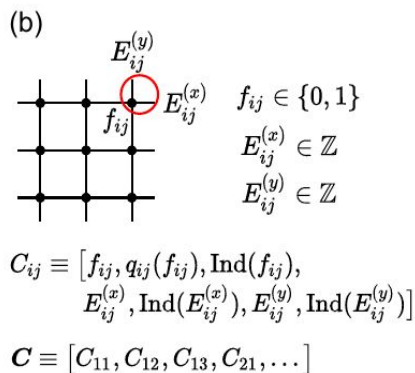

# 2+1D QED at Finite Density: String Breaking

$$H = \sum_k \frac{g_E^2}{2} E_k^2 + \frac{2}{g_B^2} B_k^2 - \kappa \psi_k^\dagger U_k \psi_{k+1} + m (-1)^k \psi_k^\dagger \psi_k$$

Zero density regime: string breaking

$$g_E^2 + 4m < g_E^2/2 \times L + 2m$$

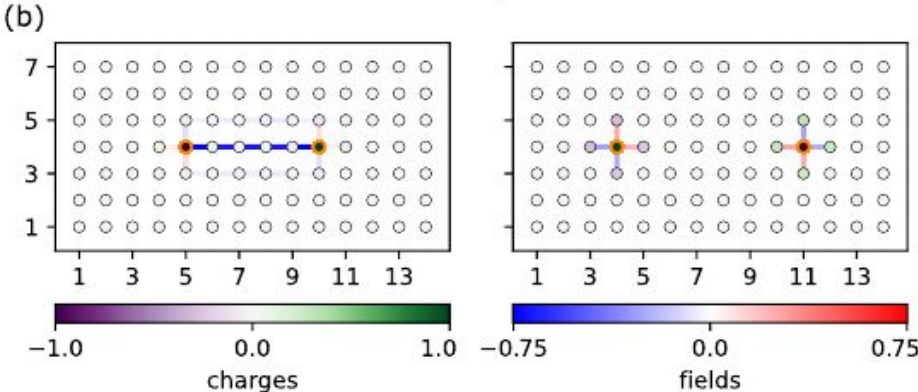
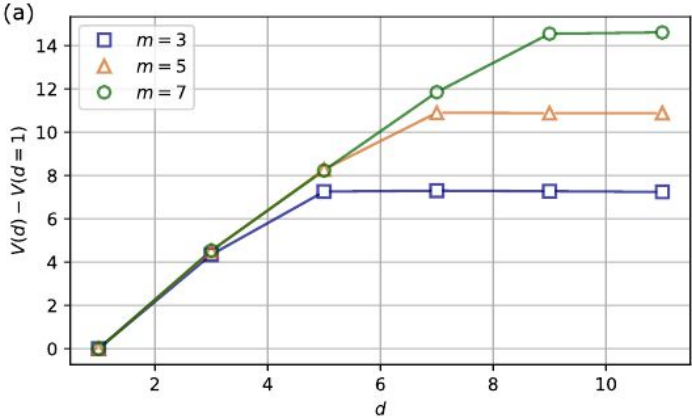

# 2+1D QED at Finite Density: String Breaking

$$H = \sum_k \frac{g_E^2}{2} E_k^2 + \frac{2}{g_B^2} B_k^2 - \kappa \psi_k^\dagger U_k \psi_{k+1} + m(-1)^k \psi_k^\dagger \psi_k$$

Zero density: hopping effect on string breaking

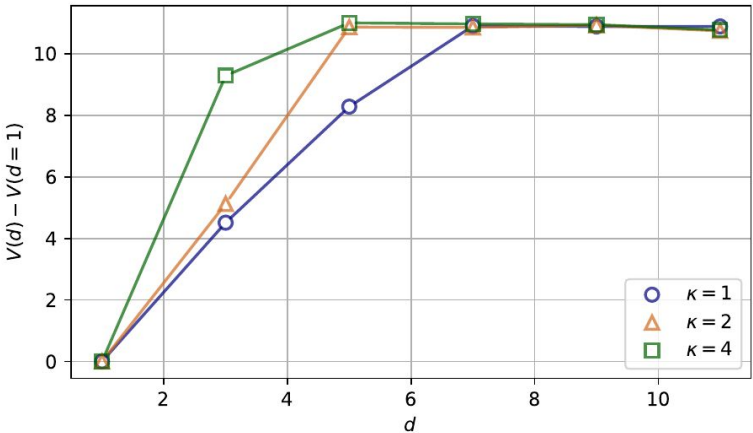

Finite density fixed doping: string breaking

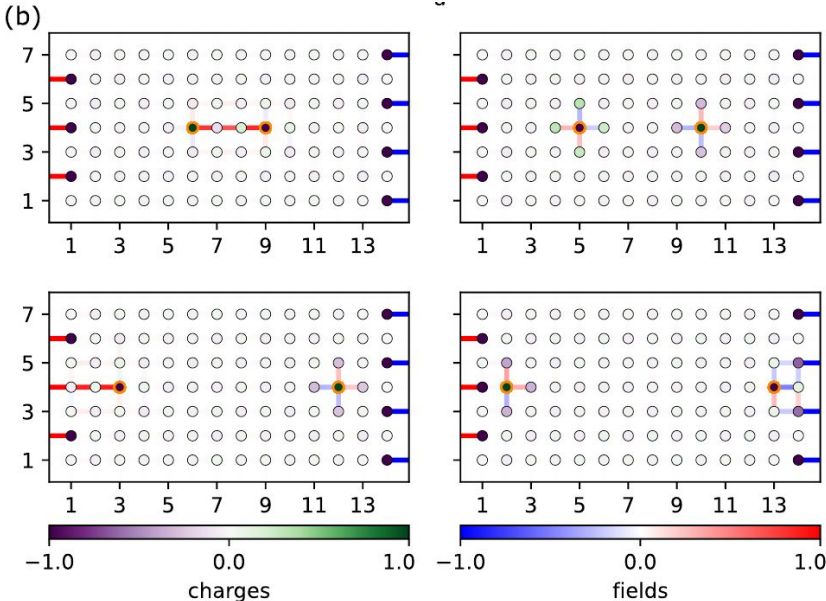

# 2+1D QED at Finite Density: Charge Crystal to Vacuum Transition

$$H = \sum_k \frac{g_E^2}{2} E_k^2 + \frac{2}{g_B^2} B_k^2 - \kappa \psi_k^\dagger U_k \psi_{k+1} + m(-1)^k \psi_k^\dagger \psi_k$$

Classical picture: 1st order transition between charge crystal phase to vacuum phase

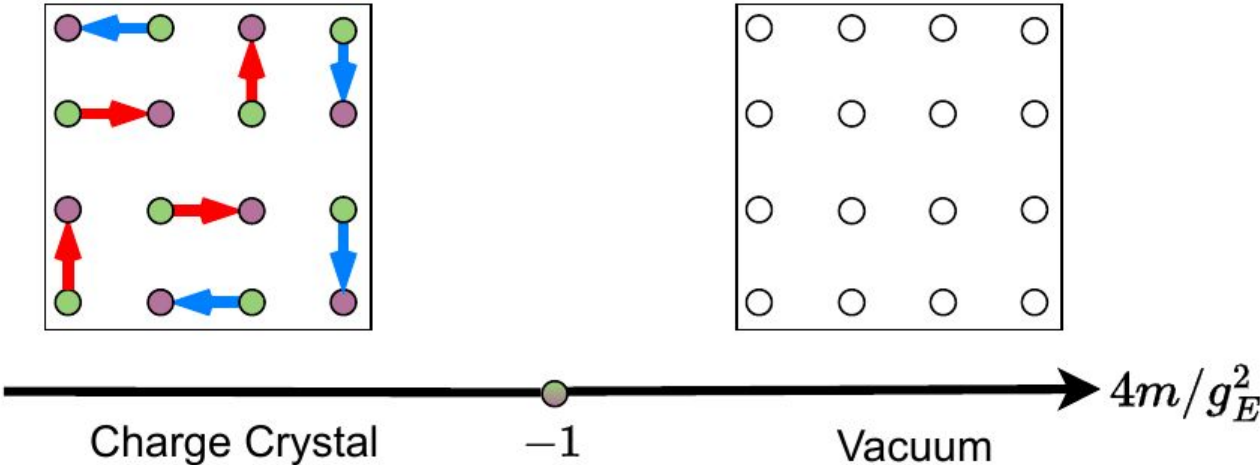

# 2+1D QED at Finite Density: Charge Crystal to Vacuum Transition

$$H = \sum_k \frac{g_E^2}{2} E_k^2 + \frac{2}{g_B^2} B_k^2 - \kappa \psi_k^\dagger U_k \psi_{k+1} + m(-1)^k \psi_k^\dagger \psi_k$$

Zero density: charge crystal to vacuum transition

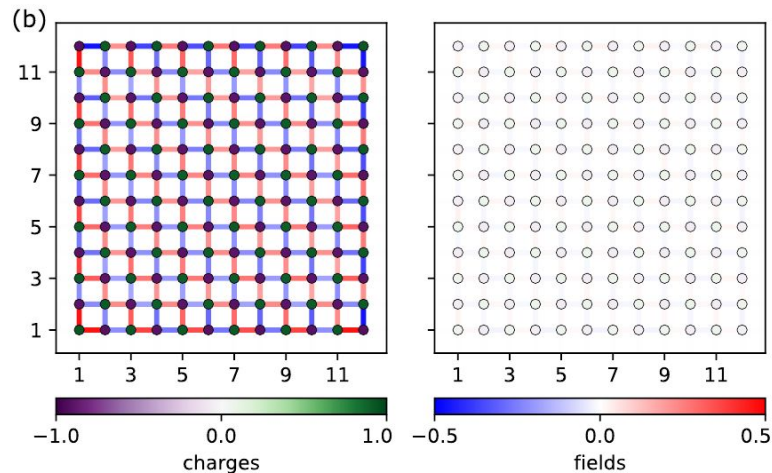
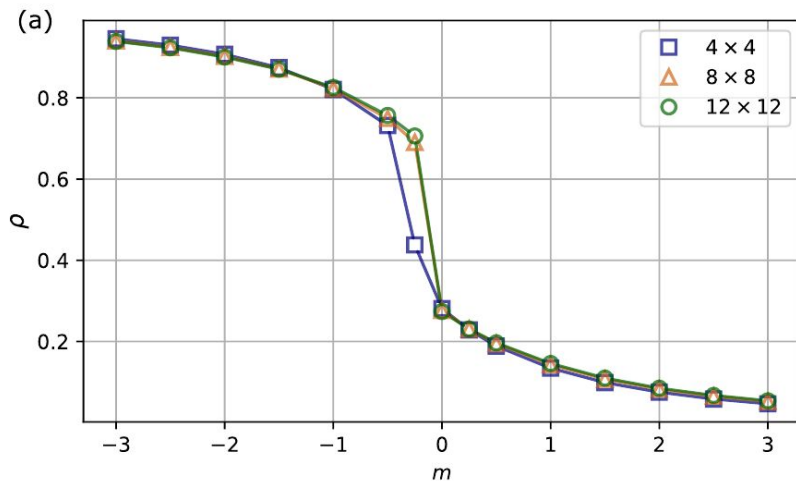

$$\rho \equiv 1/N \sum_n \left\{ \frac{1}{2} [(-1)^n + 1] \langle \hat{\psi}_n^\dagger \hat{\psi}_n \rangle - \frac{1}{2} [(-1)^n - 1] \langle \hat{\psi}_n \hat{\psi}_n^\dagger \rangle \right\}$$

# 2+1D QED at Finite Density: Charge Crystal to Vacuum Transition

$$H = \sum_k \frac{g_E^2}{2} E_k^2 + \frac{2}{g_B^2} B_k^2 - \kappa \psi_k^\dagger U_k \psi_{k+1} + m(-1)^k \psi_k^\dagger \psi_k$$

Finite density fixed doping: phase separation and charge penetration blocking caused by magnetic interaction

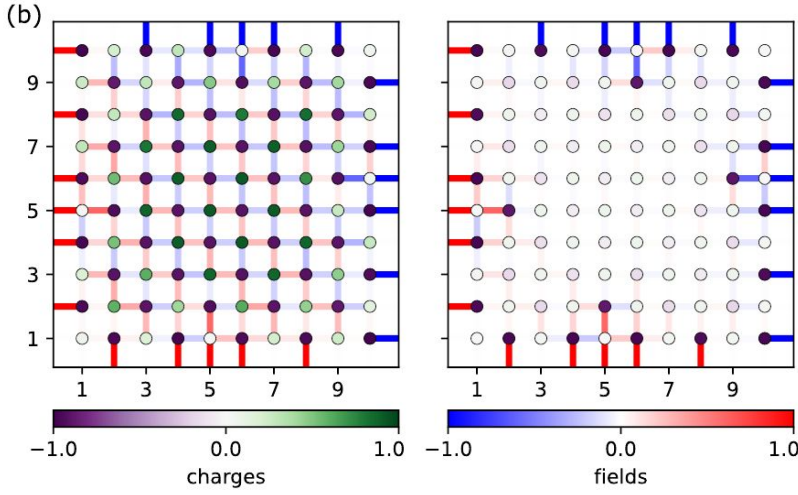
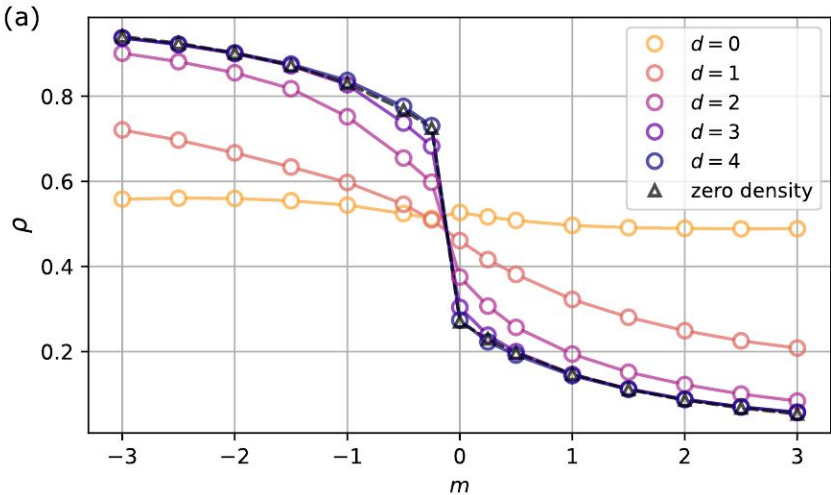

Bulk approaches zero density phase

# 2+1D QED at Finite Density: Charge Crystal to Vacuum Transition

$$H = \sum_k \frac{g_E^2}{2} E_k^2 + \frac{2}{g_B^2} B_k^2 - \kappa \psi_k^\dagger U_k \psi_{k+1} + m(-1)^k \psi_k^\dagger \psi_k$$

Finite density fixed doping: phase separation and charge penetration blocking caused by magnetic interaction

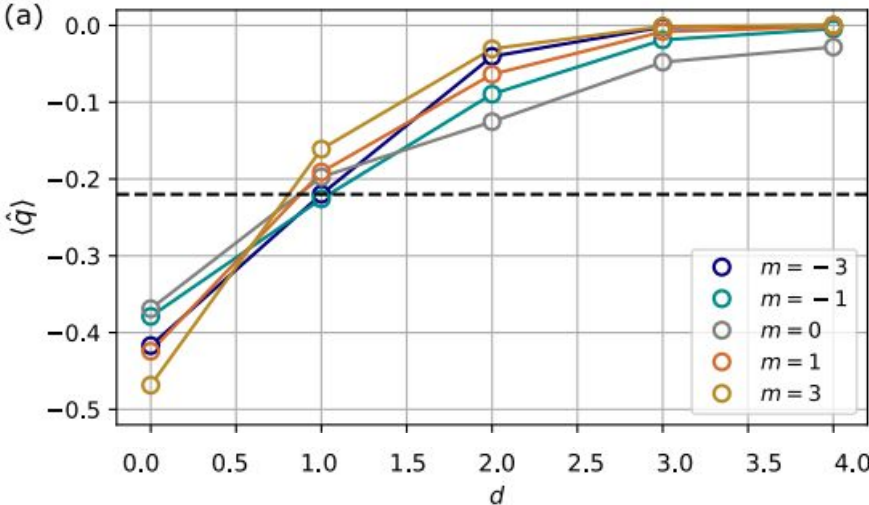

Existence of magnetic interaction

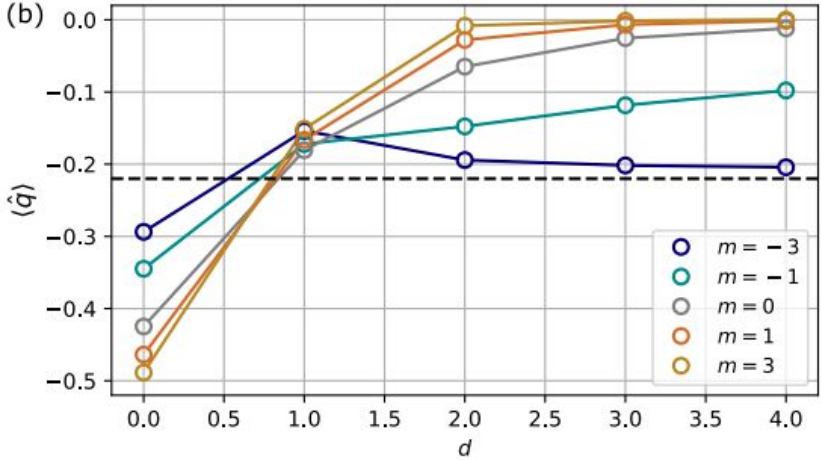

Absence of magnetic interaction  
(also in tensor network simulation  
PhysRevX.10.041040)

# 2+1D QED at Finite Density: Magnetic Phase Transition

$$H = \sum_k \frac{g_E^2}{2} E_k^2 + \frac{2}{g_B^2} B_k^2 - \kappa \psi_k^\dagger U_k \psi_{k+1} + m(-1)^k \psi_k^\dagger \psi_k$$

Competition between kinetic energy and magnetic energy

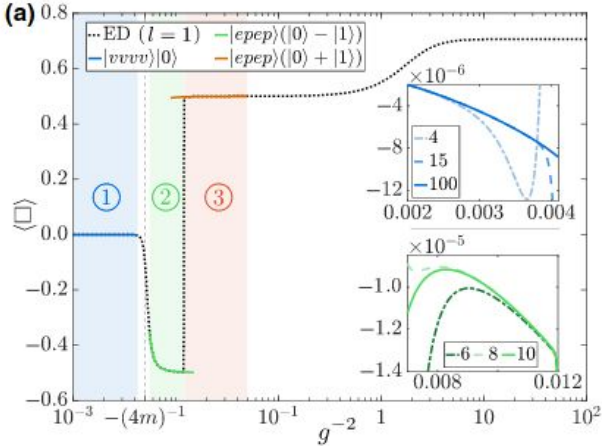

One plaquette study  
PRXQuantum.2.030334

## Questions:

1. What is the large system size phenomena?
2. What are the nature of the phase transitions?

# 2+1D QED at Finite Density: Magnetic Phase Transition

$$H = \sum_k \frac{g_E^2}{2} E_k^2 + \frac{2}{g_B^2} B_k^2 - \kappa \psi_k^\dagger U_k \psi_{k+1} + m(-1)^k \psi_k^\dagger \psi_k$$

Competition between kinetic energy and magnetic energy

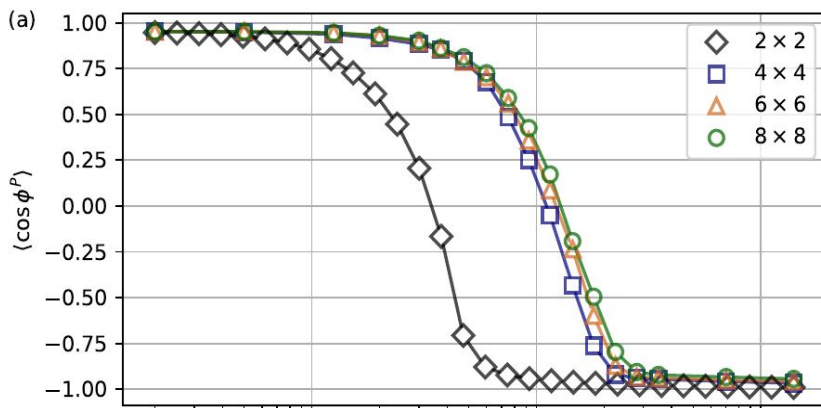

$$\langle \cos \phi^P \rangle \equiv \frac{1}{L^2} \sum_{i,j} \langle \cos \phi_{i,j}^P \rangle = \frac{1}{2L^2} \sum_{i,j} \langle \hat{P}_{i,j} + \hat{P}_{i,j}^\dagger \rangle$$

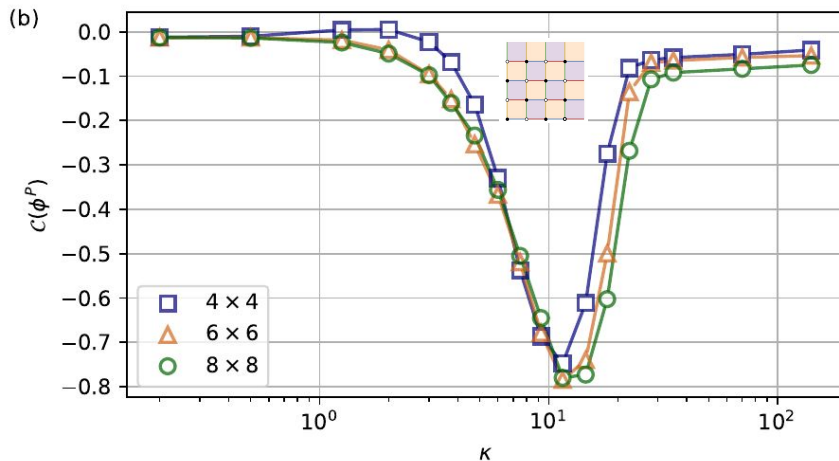

$$\mathcal{C}(\phi^P) \equiv \frac{1}{2L(L-1)} \sum_{\langle i_1, j_1; i_2, j_2 \rangle} \langle \sin \phi_{i_1, j_1}^P \sin \phi_{i_2, j_2}^P \rangle$$

# 2+1D QED at Finite Density: Magnetic Phase Transition

$$H = \sum_k \frac{g_E^2}{2} E_k^2 + \frac{2}{g_B^2} B_k^2 - \kappa \psi_k^\dagger U_k \psi_{k+1} + m(-1)^k \psi_k^\dagger \psi_k$$

Competition between kinetic energy and magnetic energy: spontaneous symmetry breaking of time-reversal symmetry

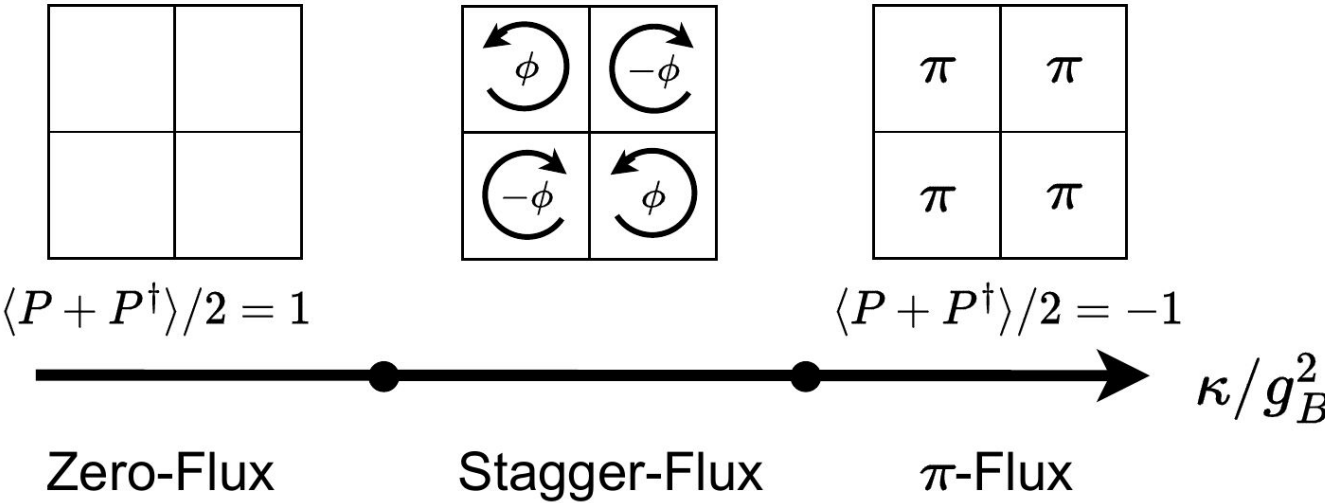

# Topological phases: Compact Maxwell-Chern-Simons Hamiltonian

## Hamiltonian Lattice Formulation of Compact Maxwell-Chern-Simons Theory

---

**Changnan Peng,<sup>a</sup> Maria Cristina Diamantini,<sup>b</sup> Lena Funcke,<sup>c</sup> Syed Muhammad Ali Hassan,<sup>d</sup> Karl Jansen,<sup>d,e</sup> Stefan Kühn,<sup>e</sup> Di Luo,<sup>a,f,g</sup> Pranay Naredi<sup>d,e</sup>**

<sup>a</sup>*Department of Physics, Massachusetts Institute of Technology, Cambridge, Massachusetts 02139, USA*

<sup>b</sup>*NiPS Laboratory, INFN and Dipartimento di Fisica e Geologia, University of Perugia, Via A. Pascoli, I-06100 Perugia, Italy*

<sup>c</sup>*Transdisciplinary Research Area “Building Blocks of Matter and Fundamental Interactions” (TRA Matter) and Helmholtz Institute for Radiation and Nuclear Physics (HISKP), University of Bonn, Nussallee 14-16, 53115 Bonn, Germany*

<sup>d</sup>*Computation-Based Science and Technology Research Center, The Cyprus Institute, 20 Kavafi Street, 2121 Nicosia, Cyprus*

<sup>e</sup>*CQTA, Deutsches Elektronen-Synchrotron DESY, Platanenallee 6, 15738 Zeuthen, Germany*

<sup>f</sup>*The NSF AI Institute for Artificial Intelligence and Fundamental Interactions*

<sup>g</sup>*Department of Physics, Harvard University, Cambridge, MA 02138, USA*

*E-mail: [cnpeng@mit.edu](mailto:cnpeng@mit.edu), [cristina.diamantini@pg.infn.it](mailto:cristina.diamantini@pg.infn.it),  
[lfuncke@uni-bonn.de](mailto:lfuncke@uni-bonn.de), [diluo@mit.edu](mailto:diluo@mit.edu)*

# Topological phases: 2+1D QED with Wilson Fermions

arxiv. 2504.21828

## A Path to Quantum Simulations of Topological Phases: (2+1)D Quantum Electrodynamics with Wilson Fermions

Sriram Bharadwaj,<sup>1</sup> Emil Rosanowski,<sup>2</sup> Simran Singh,<sup>2</sup> Alice Di Tucci,<sup>3</sup>  
Changnan Peng,<sup>4</sup> Karl Jansen,<sup>3,5</sup> Lena Funcke,<sup>2</sup> and Di Luo<sup>6,7,8,\*</sup>

arxiv. 2603.05616

## Hamiltonian Lattice QED<sub>3</sub> with One and Two Flavors of Wilson Fermions: Topological Structure and Response

Sriram Bharadwaj,<sup>1</sup> Emil Rosanowski,<sup>2</sup> Simran Singh,<sup>2</sup> Alice Di Tucci,<sup>3</sup>  
Changnan Peng,<sup>4</sup> Karl Jansen,<sup>3,5</sup> Lena Funcke,<sup>2</sup> and Di Luo<sup>6,7,8,\*</sup>



# Neural Quantum Field States for Continuum QFT

*Q: How to simulate continuum quantum field theories?*

A: Neural quantum field states

# Variational Neural-Network Ansatz for Continuum Quantum Field Theory

--- Develop neural quantum field state for continuum quantum field theory with applications to Lieb-Liniger Model, Calogero-Sutherland Model, Regularized Klein-Gordon Model.

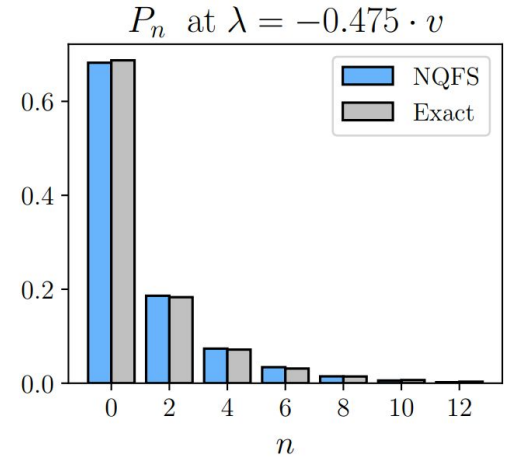
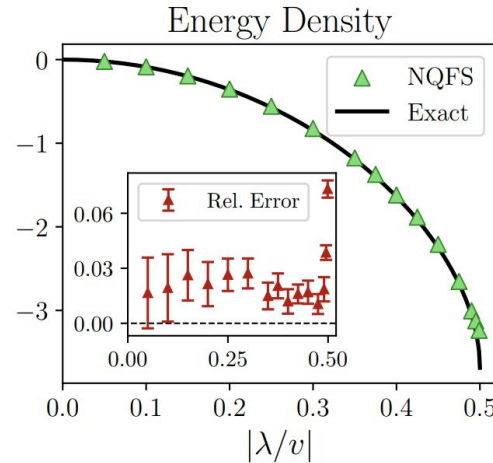
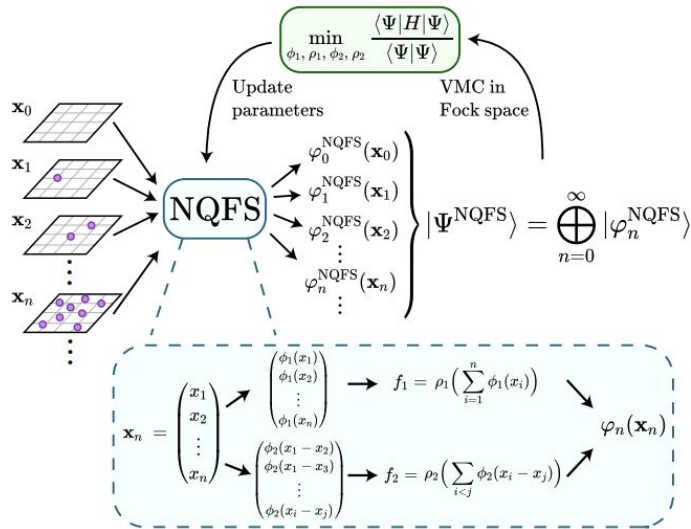

# Neural Quantum Field States for Continuum QFT

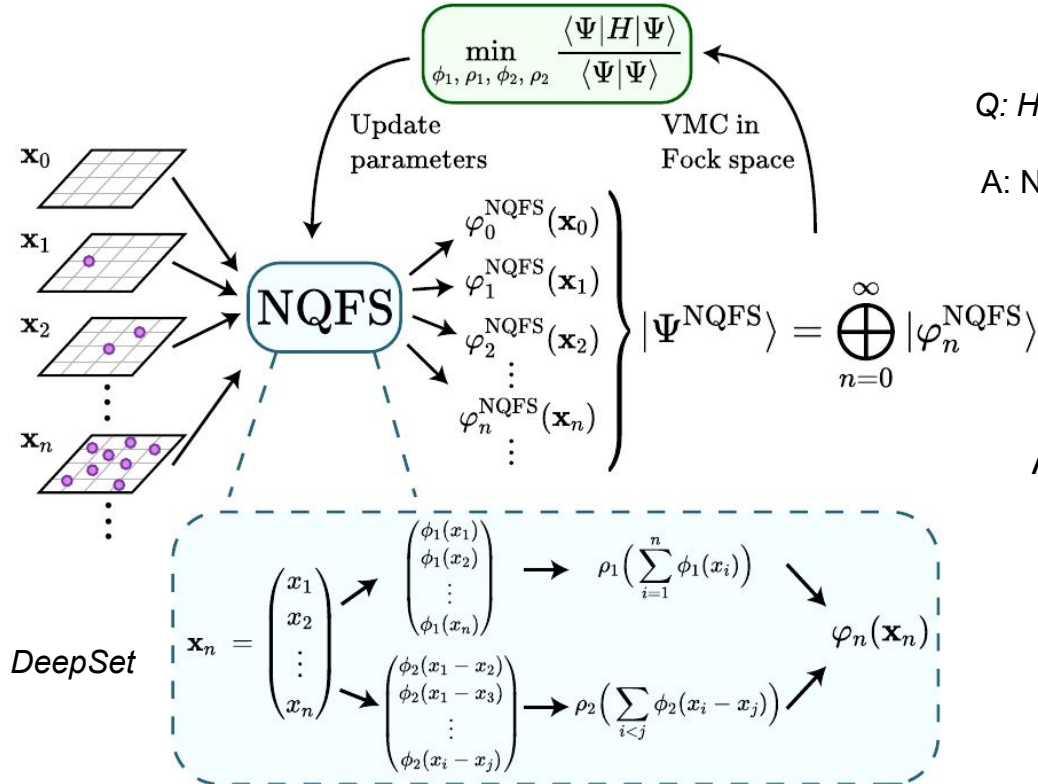

Q: How to simulate continuum quantum field theories?

A: Neural quantum field states

Applications:

- Lieb-Liniger Model
- Calogero-Sutherland Model
- Regularized Klein-Gordon Model

# Neural Quantum Field States for Continuum QFT

## Regularized Klein-Gordon Model

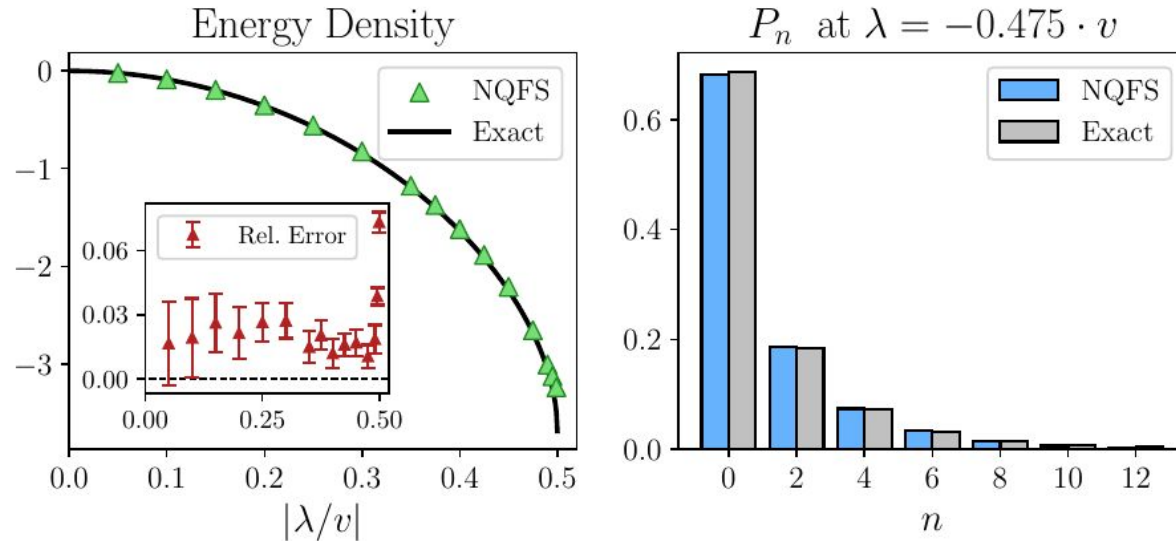

$$H_{\text{KG}} = \frac{1}{2} \int dx |\hat{\pi}(x)|^2 + |\nabla \hat{\phi}(x)|^2 + m^2 |\hat{\phi}(x)|^2$$

# Neural Quantum Field States for Continuum QFT

## Regularized Klein-Gordon Model

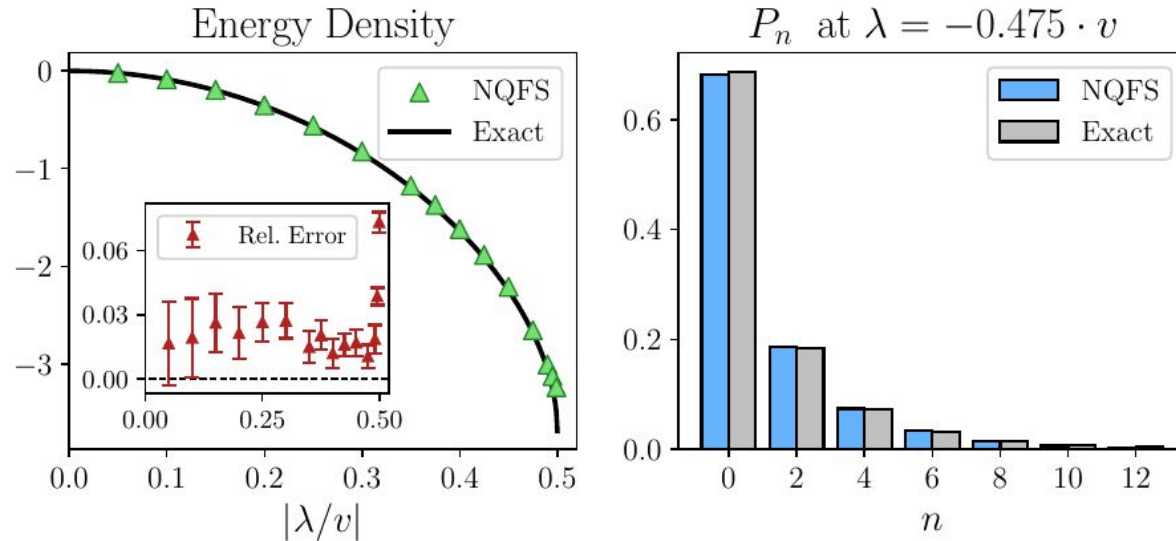

$$H_{\text{KG}} = \frac{1}{2} \int dx |\hat{\pi}(x)|^2 + |\nabla \hat{\phi}(x)|^2 + m^2 |\hat{\phi}(x)|^2$$

# Towards Non-equilibrium Quantum Dynamics

## Autoregressive Neural Network for Simulating Open Quantum Systems via a Probabilistic Formulation

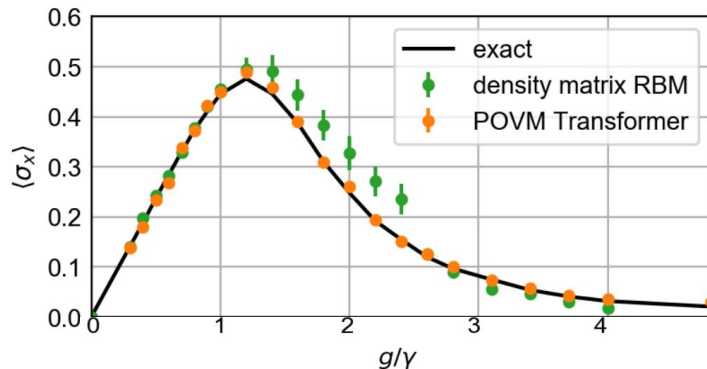

Accurate results on 1D and 2D steady states and dissipative dynamics of spin systems based on POVM

Di Luo†, Zhuo Chen†, Juan Carrasquilla, Bryan K. Clark, *Phys. Rev. Lett.* 128, 090501

## Real-time Dynamics of the Schwinger Model as an Open Quantum System with Neural Density Operators

Joshua Lin, Di Luo, Xiaojun Yao, Phiala E. Shanahan, *JHEP06(2024)211*

## QFlow: Generative Modeling for Differential Equations of Open Quantum Dynamics with Normalizing Flows

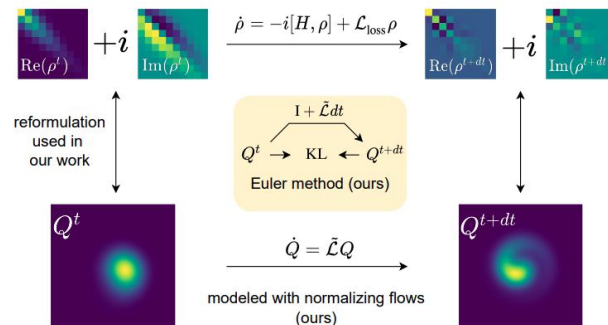

Real-time dissipative dynamics of bosonic system

Owen Dugan, Peter Y. Lu, Rumen Dangovski, Di Luo\*, Marin Soljačić, *ICML 2023*

## Probabilistic Simulation of Quantum Circuits with the Transformer

Juan Carrasquilla, Di Luo, et al. *Phys. Rev. A* 104, 032610

# Conclusions and Outlook

- New opportunities from neural quantum states for simulating quantum field theories
- New attempts to handle gauge symmetries, sign problems, continuous fields
- Study ground state phase diagram, finite temperature physics, and real-time dynamics of quantum field theories

*Postdoc and student research openings at Tsinghua University ([diluo@tsinghua.edu.cn](mailto:diluo@tsinghua.edu.cn))*

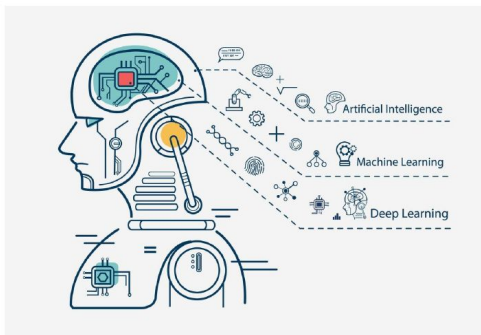

Artificial Intelligence



Nature Intelligence



Nature & Artificial Intelligence