

Probing High-scale Physics with Neutrinoless Double Beta Decay

Frank Deppisch
f.deppisch@ucl.ac.uk

University College London

Neutrinos in the SM

- ▶ Three “active” neutrino flavours ν_e, ν_μ, ν_τ
- ▶ Form LH $SU(2)$ doublets with LH charged leptons
- ▶ No RH $SU(2)$ singlet neutrino states
- ▶ Active neutrinos are massless
- ▶ Most popular extension: Introduction of RH (sterile, HNL) neutrinos



nobelprize.org

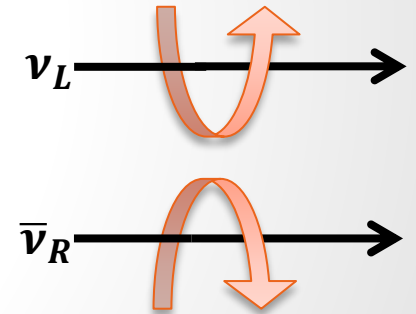

Dirac versus Majorana

- Two possibilities to define fermion mass

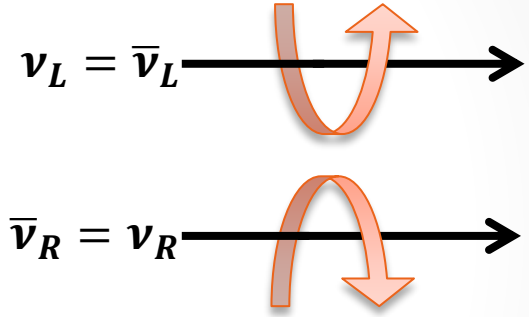
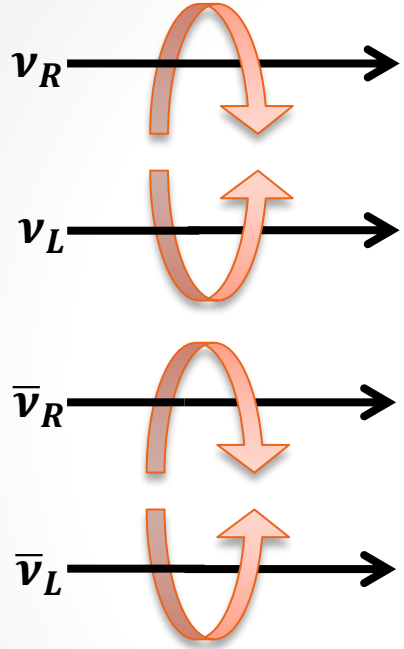
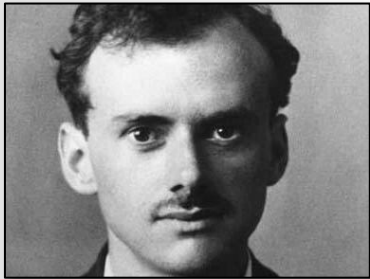

Dirac mass analogous to other fermions but with $m_\nu/\Lambda_{EW} \approx 10^{-12}$ couplings to Higgs

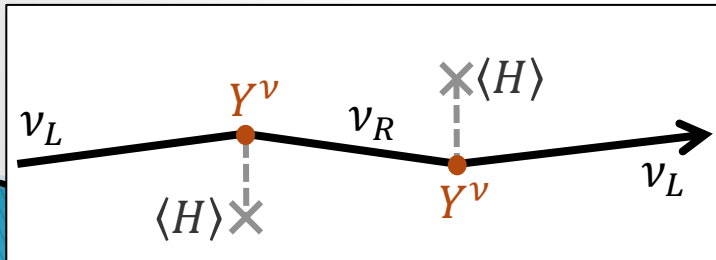

Majorana mass, using only a left-handed neutrino → Lepton Number Violation

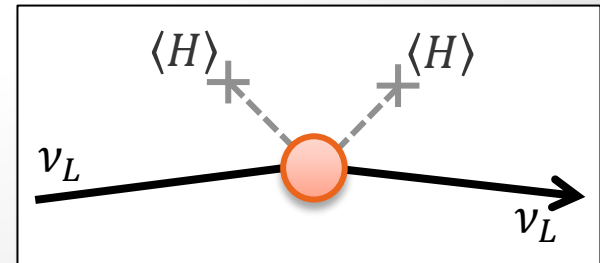

Dirac versus Majorana

- ▶ Origin of neutrino masses beyond the Standard Model
- ▶ Crucial role of total lepton number L symmetry
 - Arises accidentally as global $U(1)_L$ in SM from particle content and gauge symmetry
 - L broken non-perturbatively but $B - L$ conserved
 - Global symmetries expected to be broken gravitational effects?

$$m_\nu \approx \frac{v^2}{M_{\text{Planck}}} \approx 10^{-5} \text{ eV}$$

- Too small to explain oscillations but too large as subdominant splitting
- Connection to matter-antimatter asymmetry

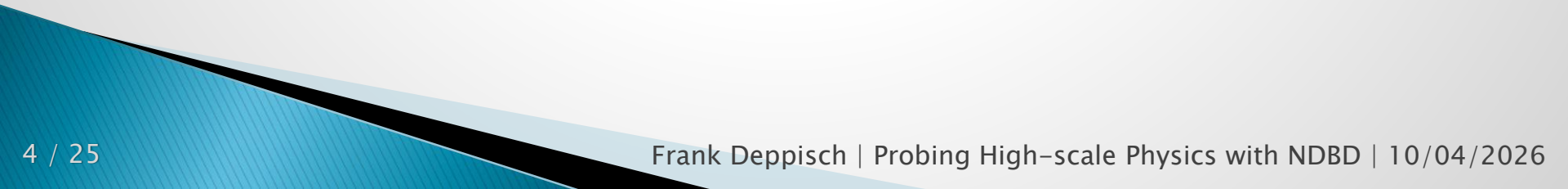

Absolute Neutrino Mass

Beta Decays

- ▶ Single beta decay

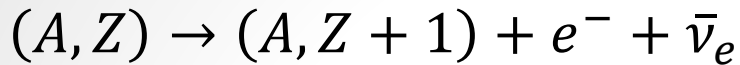

- Absolute neutrino mass

- ▶ Two- ν double beta ($2\nu\beta\beta$) decay

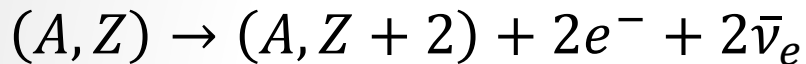

- SM allowed but sensitivity to NP

- ▶ Neutrinoless double beta ($0\nu\beta\beta$) decay

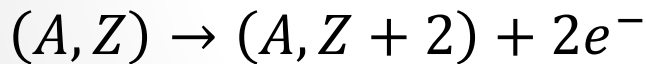

- Violation of lepton number
- Mediated by Majorana neutrinos

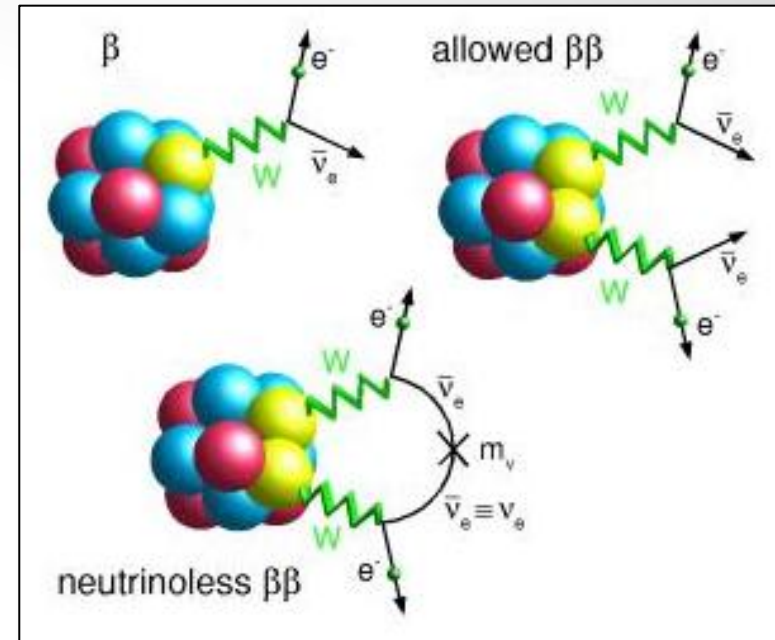

Neutrinoless Double β Decay

▶ Half-life

$$T_{1/2}^{-1} = |m_{\beta\beta}|^2 G^{0\nu} |M^{0\nu}|^2$$

▶ Particle Physics

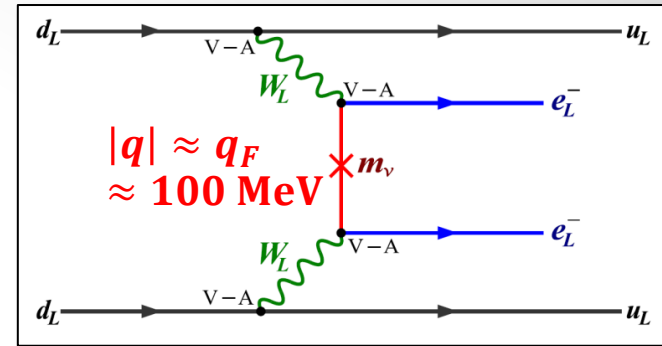

$$\mathcal{A}_{\mu\nu}^{lep} = \frac{1}{4} \sum_{i=1}^3 U_{ei}^2 \gamma_\mu (1 + \gamma_5) \frac{\not{q} + m_{\nu_i}}{q^2 - m_{\nu_i}^2} \gamma_\nu (1 - \gamma_5) \approx \frac{\gamma_\mu (1 + \gamma_5) \gamma_\nu}{4q^2} \sum_{i=1}^3 U_{ei}^2 m_{\nu_i} \rightarrow m_{\beta\beta}$$

▶ Atomic Physics

- Leptonic phase space $G^{0\nu} \propto Q^5$

▶ Nuclear Physics

- Nuclear transition matrix element $M^{0\nu} \approx 1$ but large uncertainties, factor 2-3

$$\frac{10^{25} \text{ y}}{T_{1/2}} \approx \left(\frac{|m_{\beta\beta}|}{\text{eV}} \right)^2$$

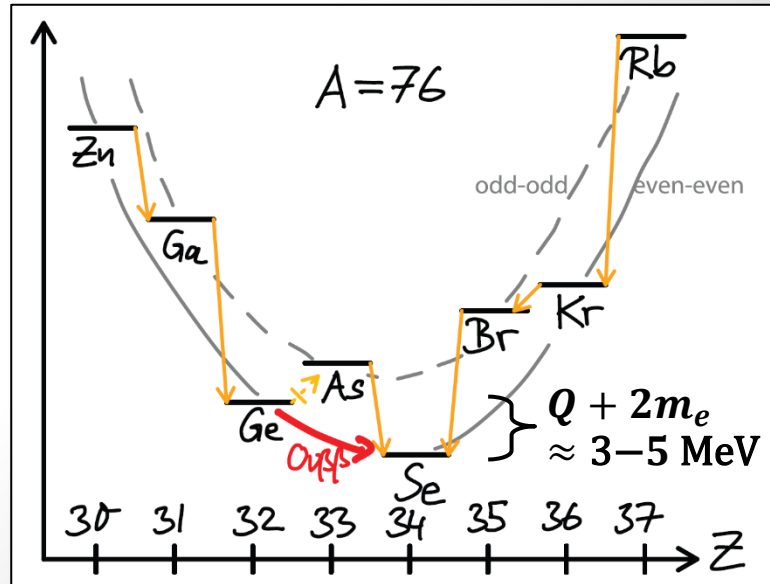

Neutrinoless Double β Decay

The “Brute Force” Approach



The “Peak-Squeezer” Approach

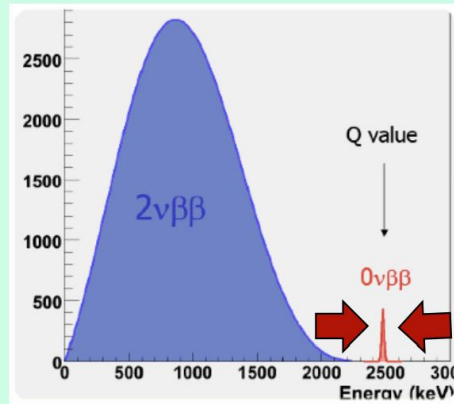

The “Final-State Judgement” Approach

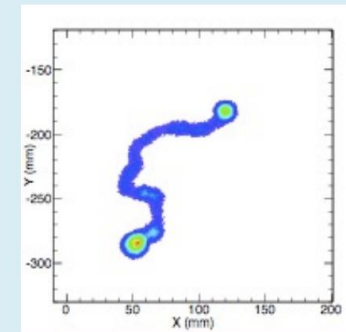

KamLAND-Zen
(¹³⁶Xe)

SNO+
(¹³⁰Te)

**CUORICINO/
CUORE**
(¹³⁰Te)

MAJORANA
(⁷⁶Ge)

GERDA (⁷⁶Ge)

LEGEND
(⁷⁶Ge)

**EXO
/nEXO**
(¹³⁶Xe)

**NEMO/
SuperNEMO**
(various/⁸²Se)

NEXT
(¹³⁶Xe)

JUNO-ββ
(¹³⁶Xe, ¹³⁰Te)

**CUPID
-Mo**
(¹⁰⁰Mo)

AMORE (¹⁰⁰Mo)

+more future ideas...

Neutrinoless Double β Decay

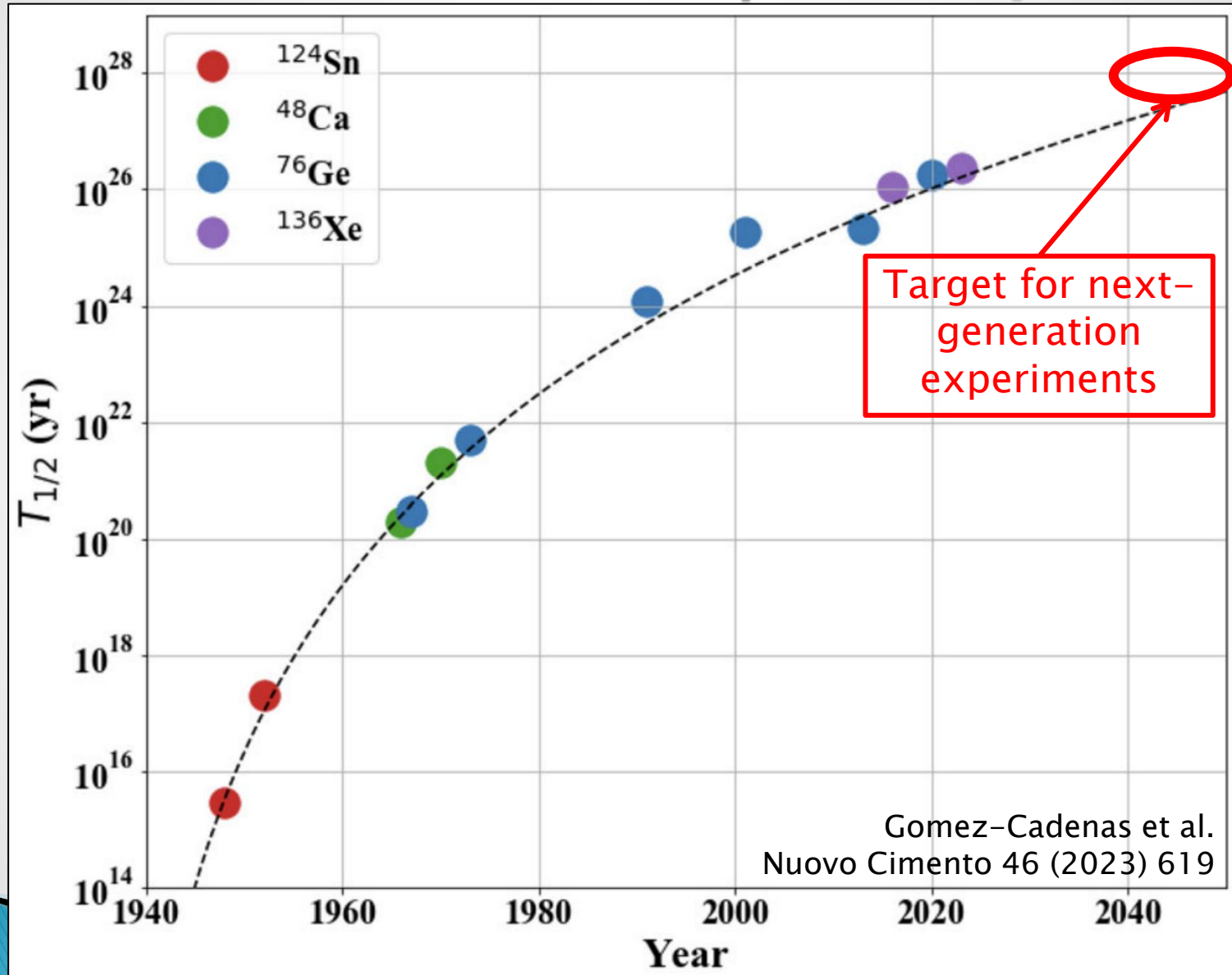

Three Active Neutrinos

▶ Effective $0\nu\beta\beta$ Mass

degenerate ν & $\theta_{13} \approx 0$

$$|m_{\beta\beta}| = |c_{12}^2 c_{13}^2 m_{\nu_1} + s_{12}^2 c_{13}^2 m_{\nu_2} e^{i\phi_{12}} + s_{13}^2 m_{\nu_3} e^{i\phi_{13}}| \approx m_{\nu} \sqrt{1 - \sin^2(2\theta_{12}) \sin^2(\phi_{12}/2)}$$

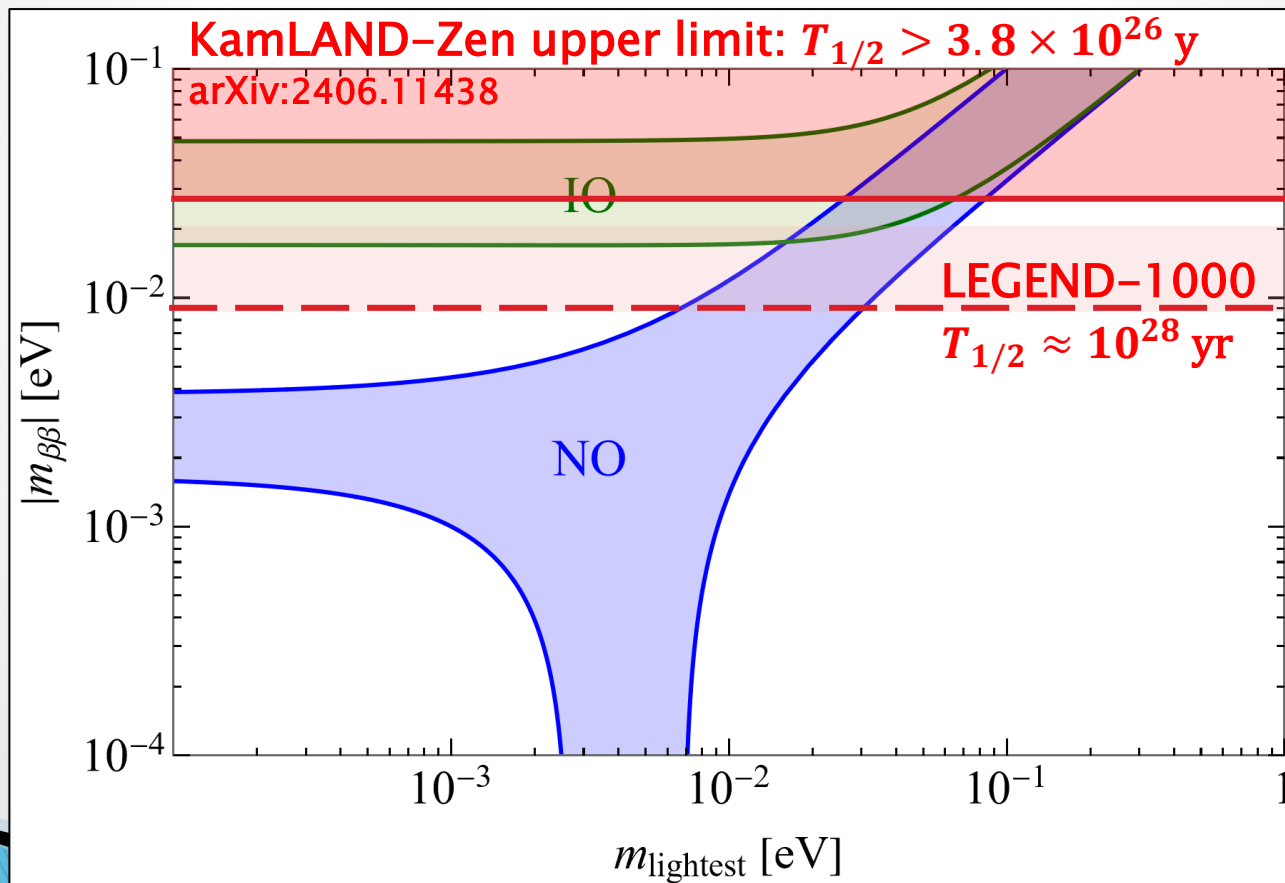

Three Active Neutrinos

▶ Effective $0\nu\beta\beta$ Mass

degenerate ν & $\theta_{13} \approx 0$

$$|m_{\beta\beta}| = |c_{12}^2 c_{13}^2 m_{\nu_1} + s_{12}^2 c_{13}^2 m_{\nu_2} e^{i\phi_{12}} + s_{13}^2 m_{\nu_3} e^{i\phi_{13}}| \approx m_{\nu} \sqrt{1 - \sin^2(2\theta_{12}) \sin^2(\phi_{12}/2)}$$

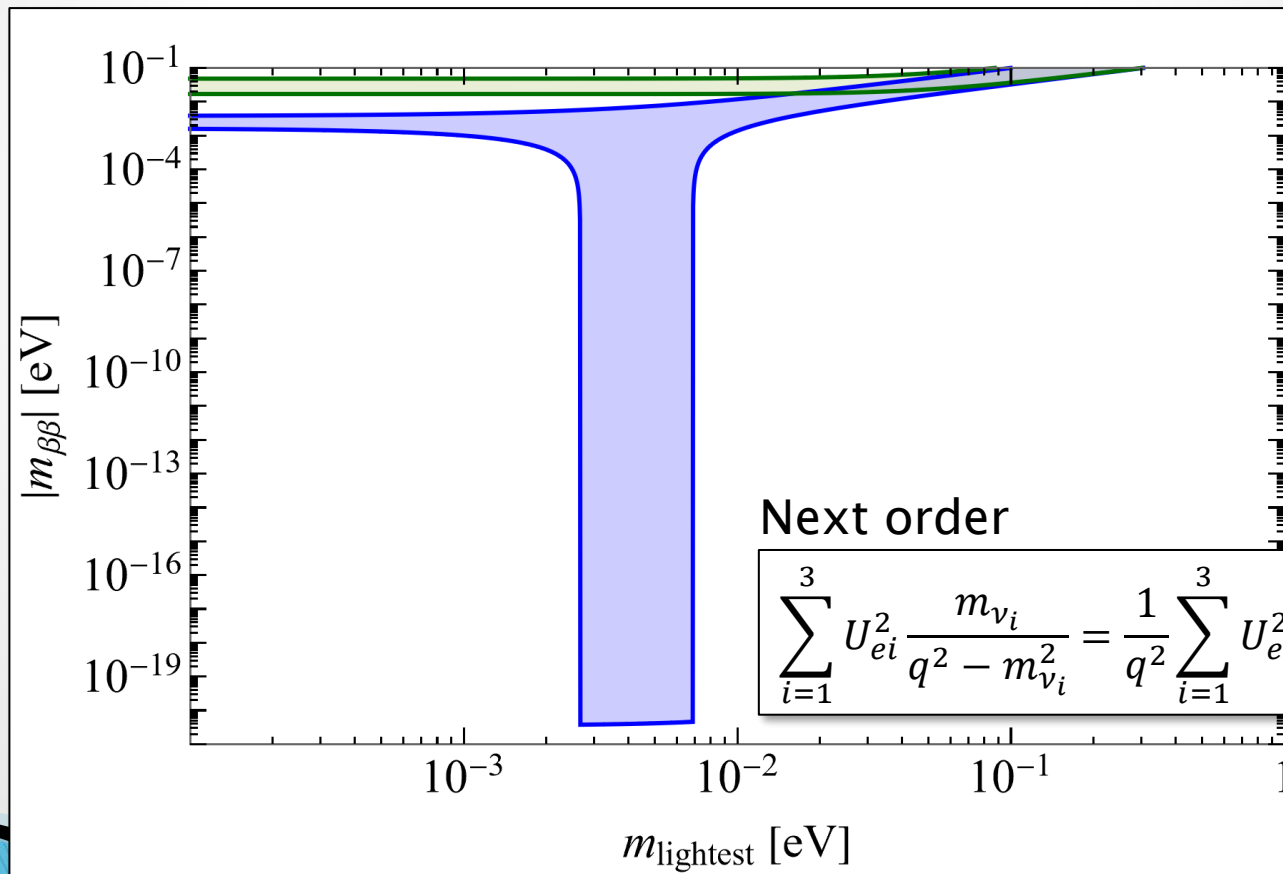

Three Active Neutrinos

- ▶ Minimal SM extension for Majorana neutrinos

$$L = L_{SM} + \frac{1}{2} \Lambda_{\alpha\beta}^{-1} (\overline{L_\alpha^c} \cdot \tilde{H}^*) (\tilde{H}^+ \cdot L_\beta) + \text{h.c.}$$

Weinberg operator

- ▶ Reconstruct operator scales from oscillation and $0\nu\beta\beta$ data

- Best NO fit oscillation values (incl. δ_{CP}) and fixed NME
- $m_{ee} = m_{\beta\beta} \rightarrow \Lambda_{ee}$ directly from $0\nu\beta\beta$
- Variation over $m_{lightest}$ and Majorana phases

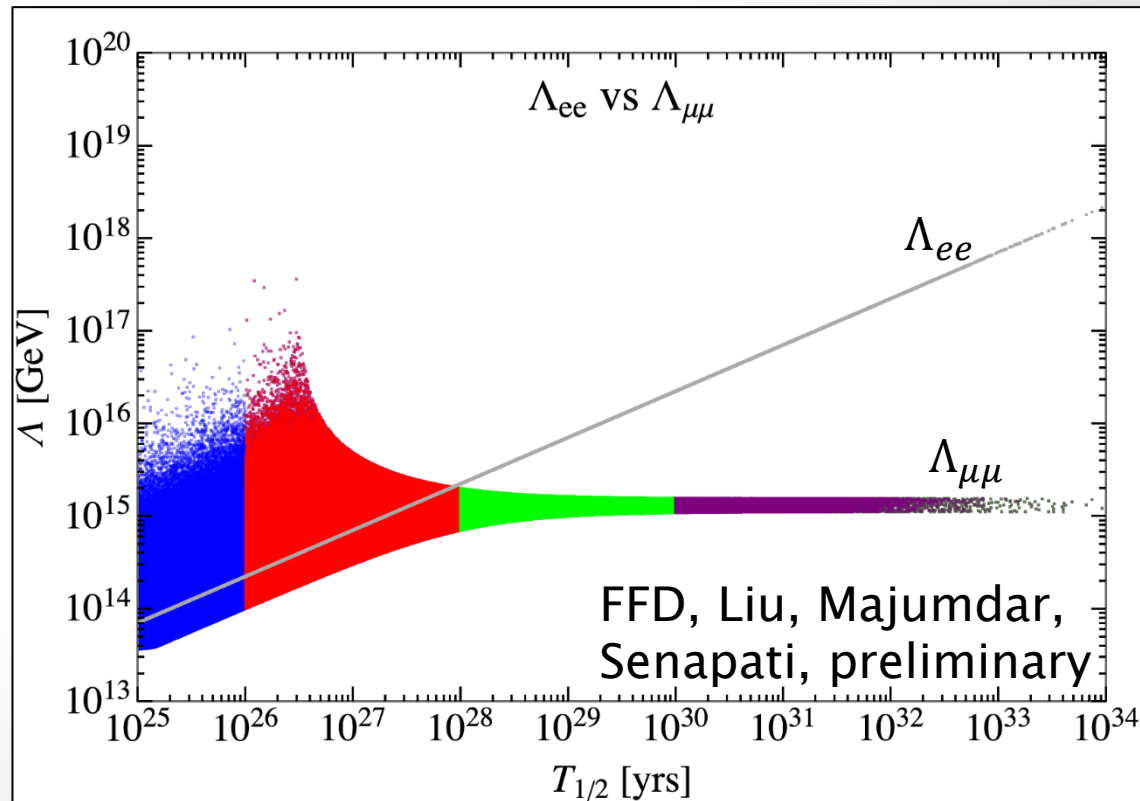

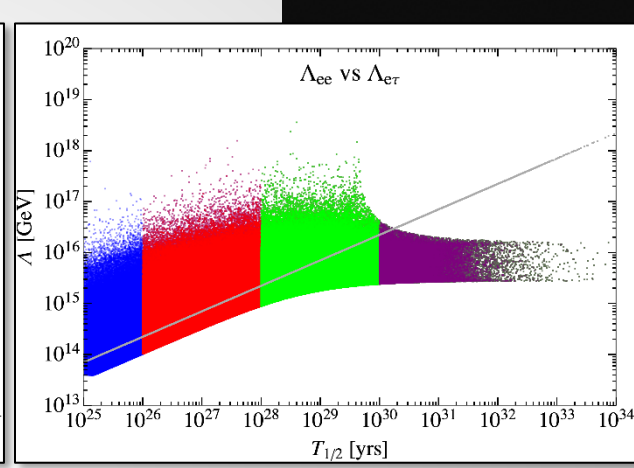
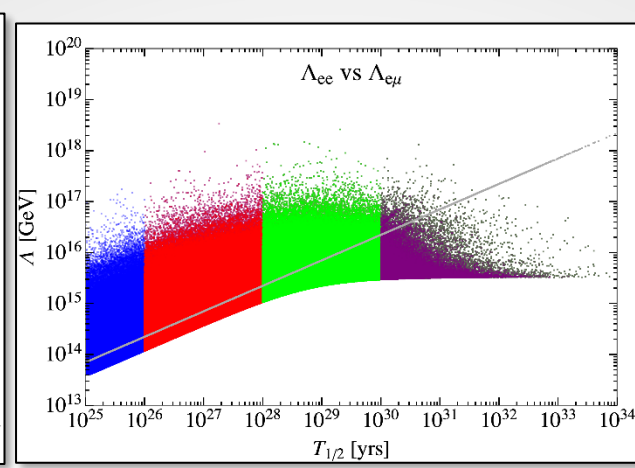
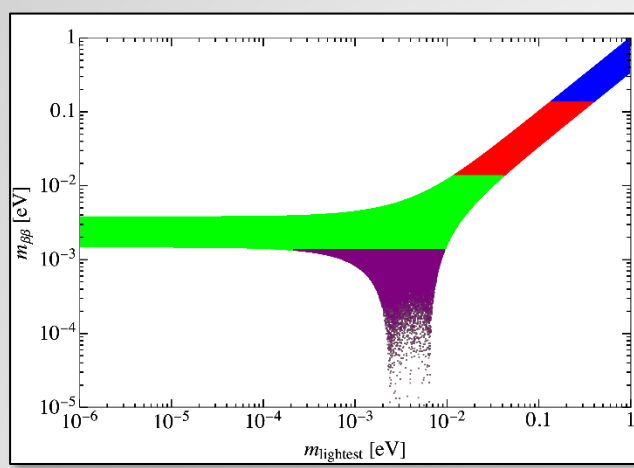

Normal Ordering

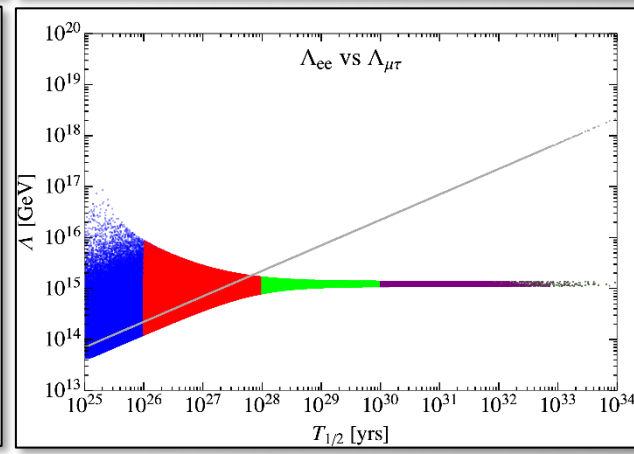
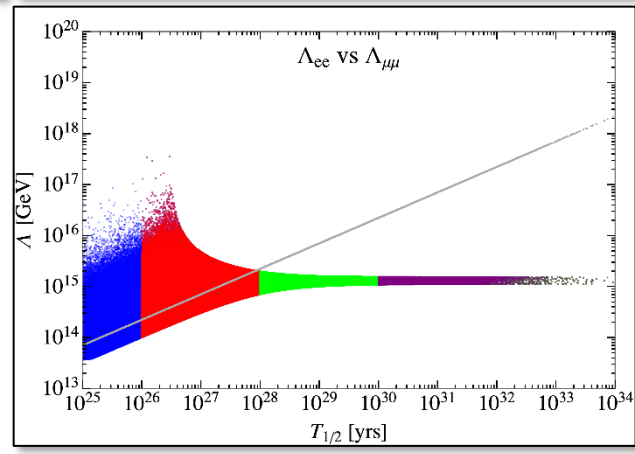

FFD, Liu, Majumdar,
Senapati, preliminary

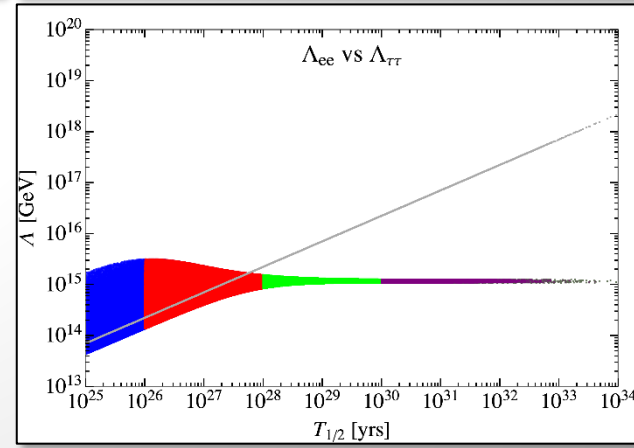

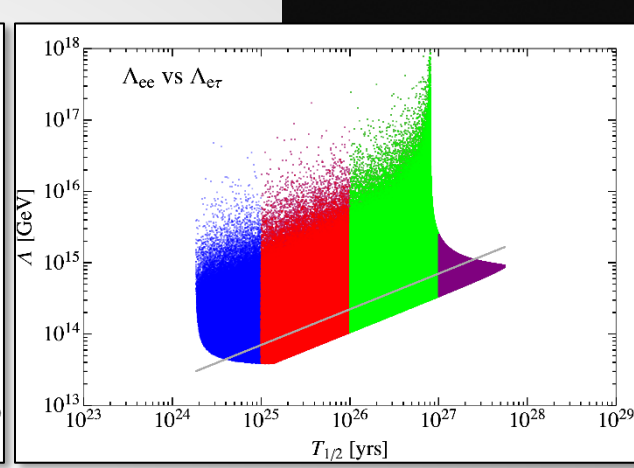
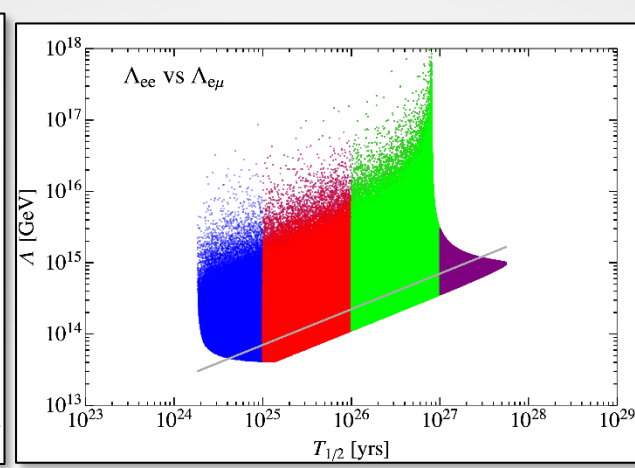
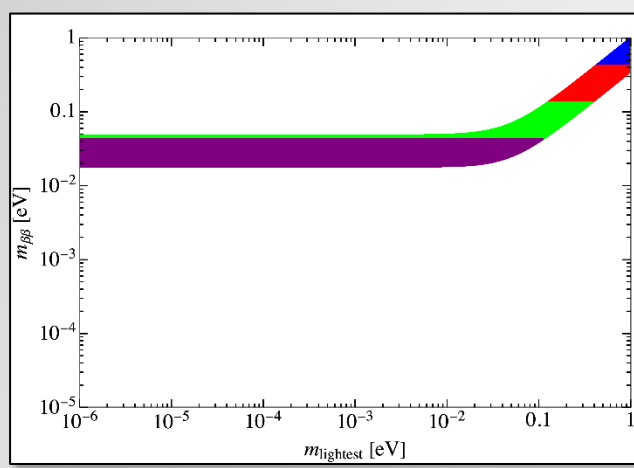

Inverse Ordering

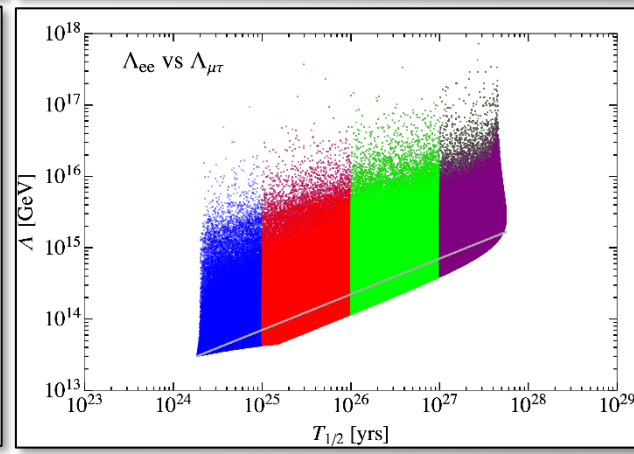
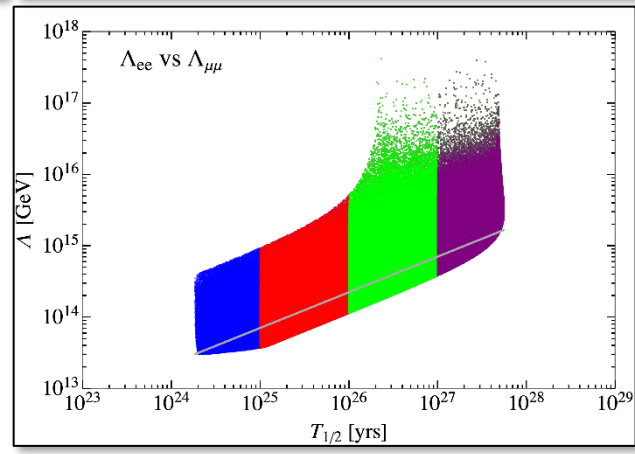

FFD, Liu, Majumdar,
Senapati, preliminary

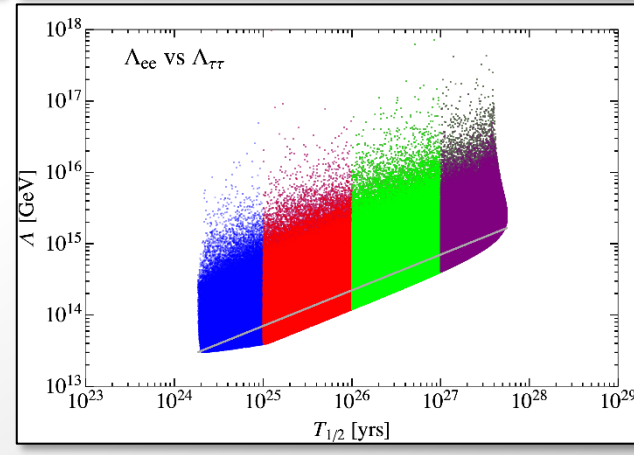

Nuclear Matrix Elements

- ▶ NMEs in different nuclear structure models

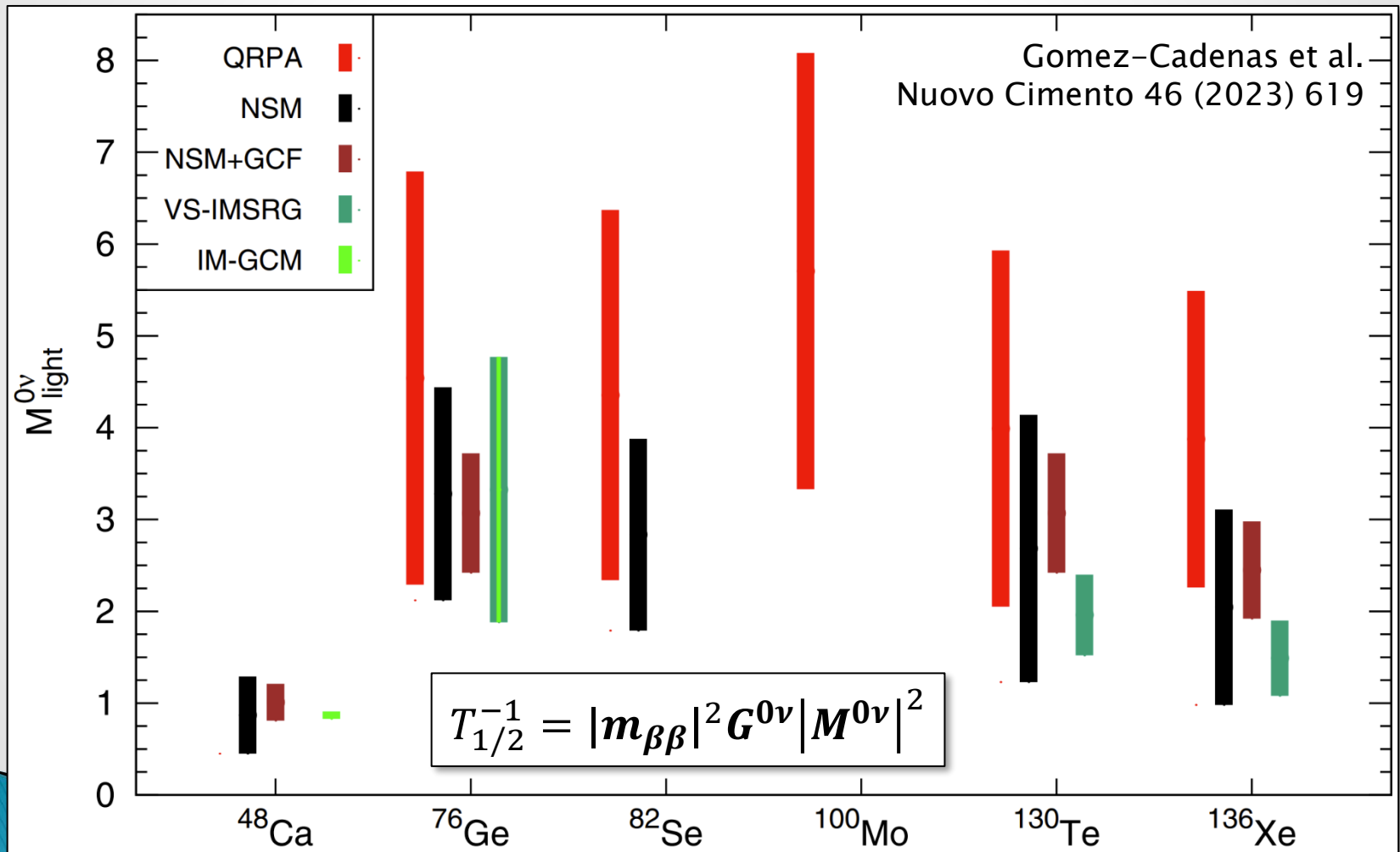

Nuclear Matrix Elements

► Uncertainty budget in ab-initio method

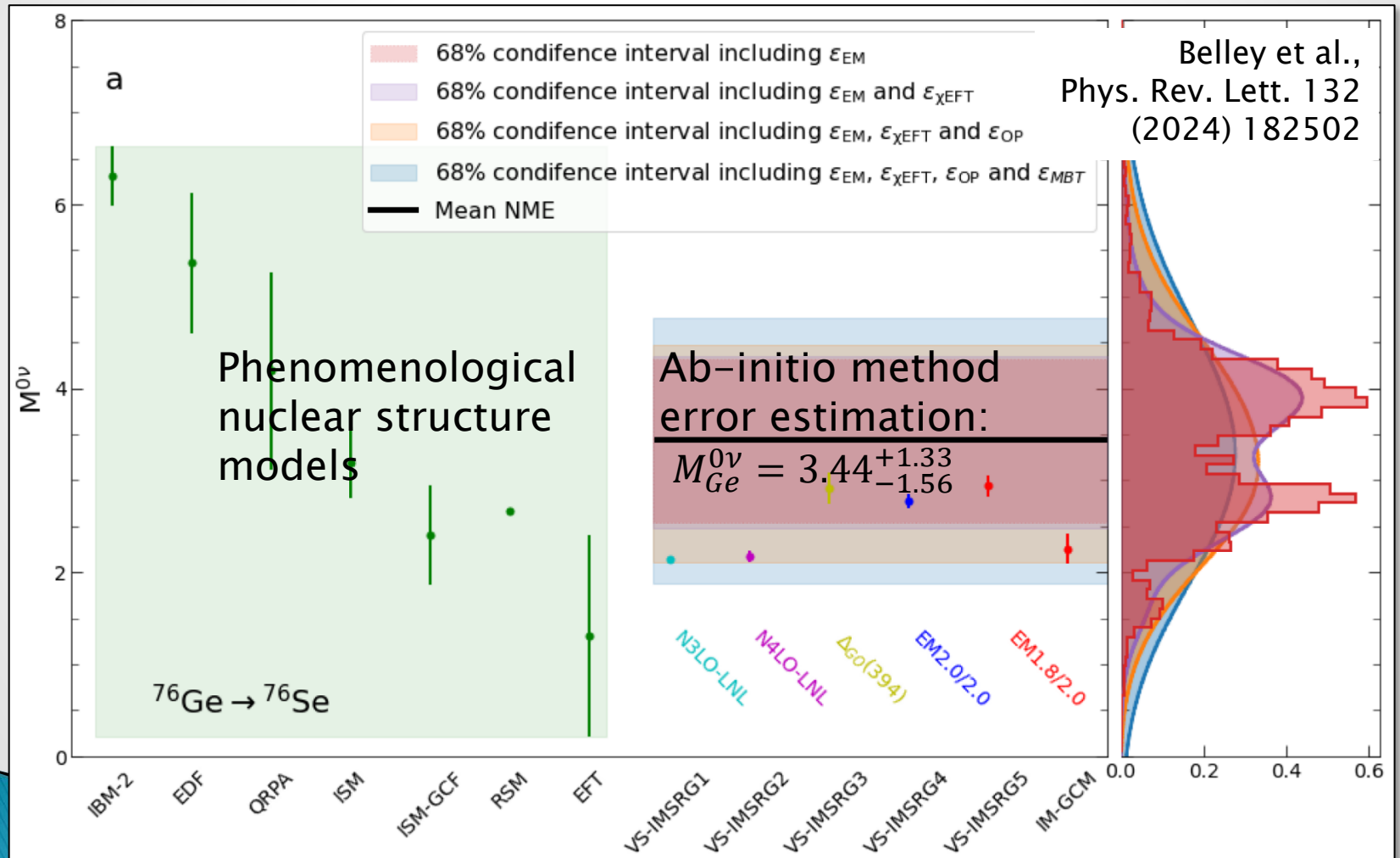

New Physics and $0\nu\beta\beta$

► Plethora of New Physics scenarios

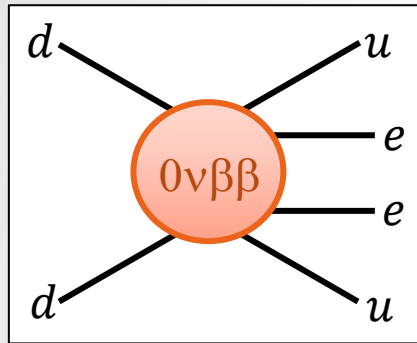

=

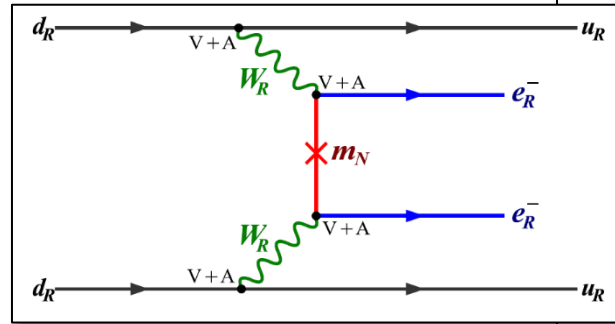

Left-Right Symmetry

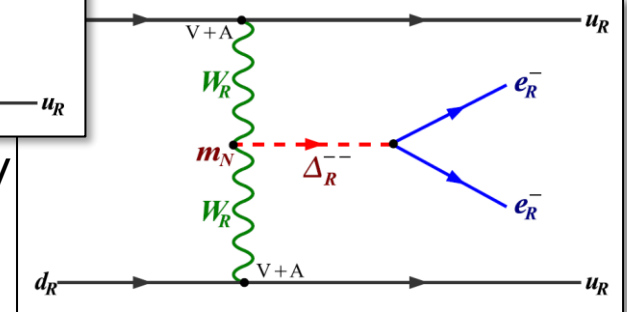
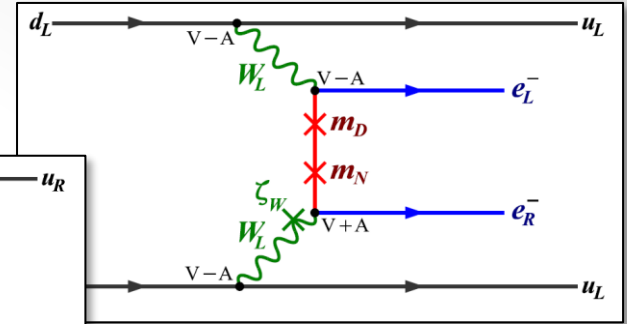

$$T_{1/2}^{-1} = \epsilon_{NP}^2 G_{NP}^{0\nu} |M_{NP}^{0\nu}|^2$$

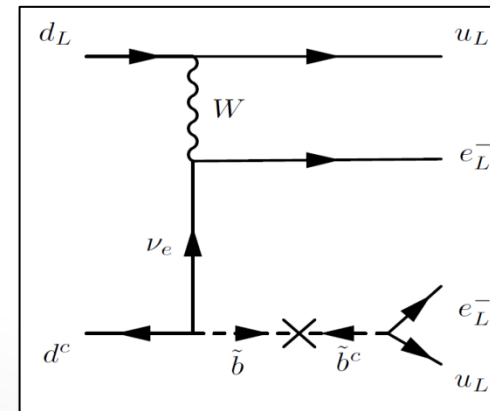

R-Parity Violating SUSY

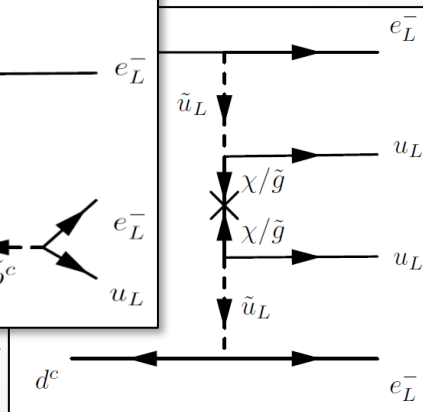

- Extra Dimensions
- Majorons
- Leptoquarks
- ...

New Physics and $0\nu\beta\beta$

► Plethora of New Physics scenarios

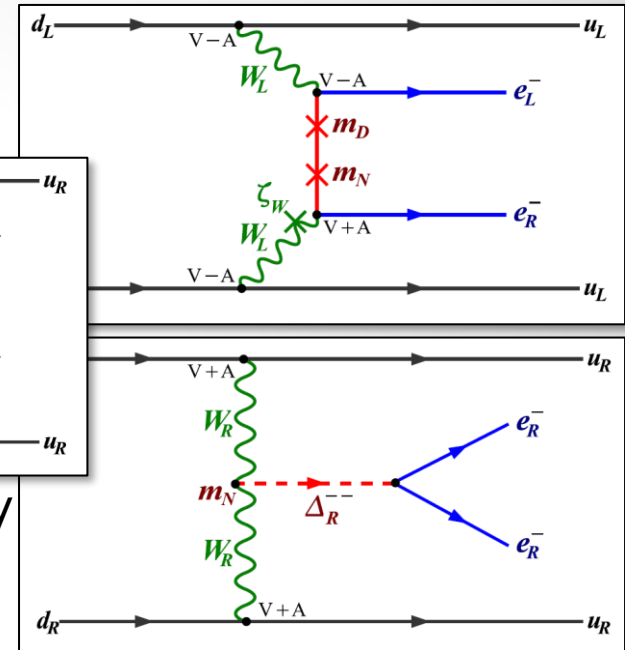
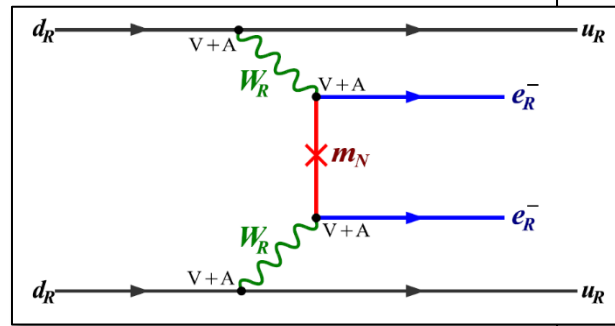
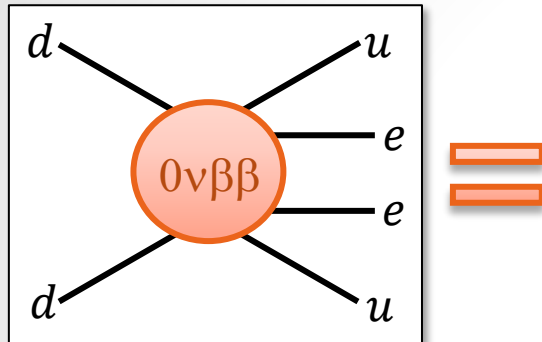

Left-Right Symmetry

$$T_{1/2}^{-1} = \epsilon_{NP}^2 G_{NP}^{0\nu} |M_{NP}^{0\nu}|^2$$

► Neutrinos still Majorana

Schechter, Valle, Phys.Rev.D 25 (1982) 2951

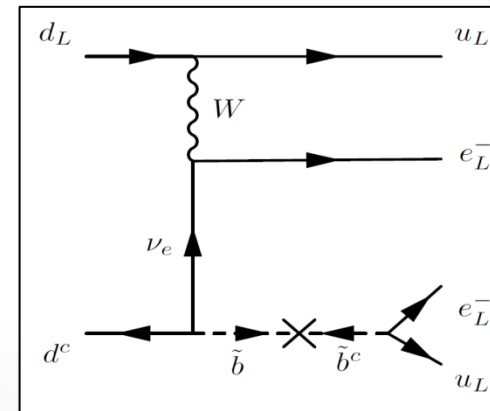
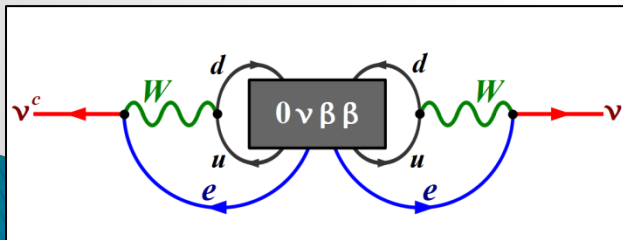

R-Parity Violating SUSY

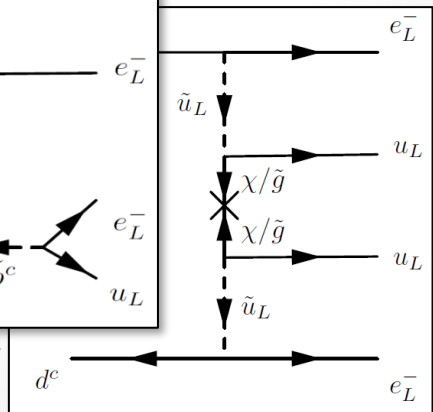

- Extra Dimensions
- Majorons
- Leptoquarks
- ...

New Physics and $0\nu\beta\beta$

Examples in Left-Right Symmetry

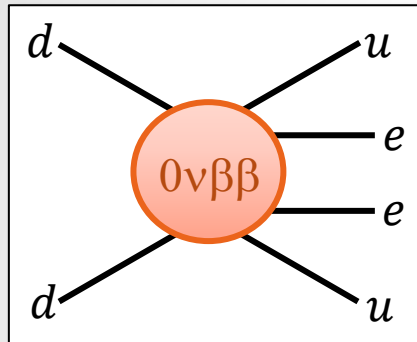

=

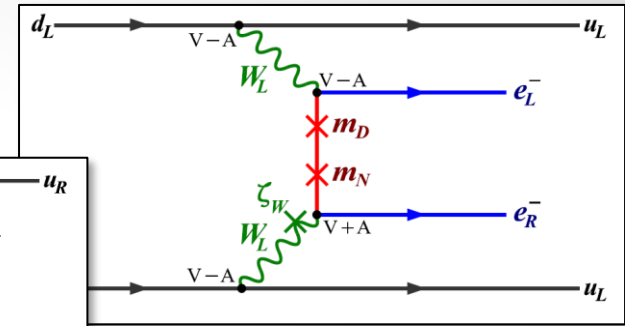
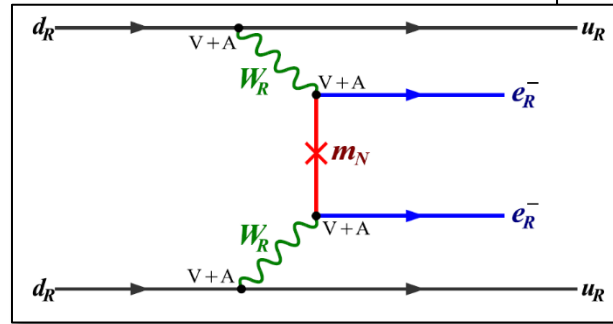

$$T_{1/2}^{-1} = \epsilon_{NP}^2 G_{NP}^{0\nu} |M_{NP}^{0\nu}|^2$$

$$\epsilon_3^{RRZ} = \sum_{i=1}^3 V_{ei}^2 \frac{m_p}{m_N} \frac{m_W^4}{m_{WR}^4} \approx \frac{10^{-8}}{(\Lambda/4 \text{ TeV})^5}$$

$$\epsilon_{V-A}^{V+A} = \sum_{i=1}^3 U_{ei} W_{ei} \tan \zeta_W \approx \frac{10^{-9}}{(\Lambda/20 \text{ TeV})^3}$$

- ▶ $0\nu\beta\beta$ probes the TeV scale
- ▶ Limits on 6D and 9D eff. operators

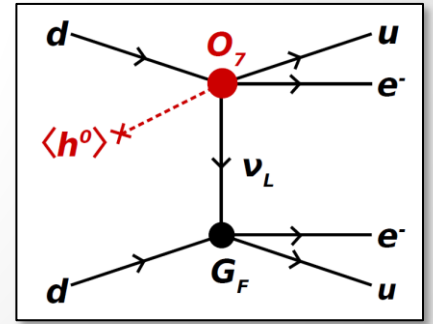
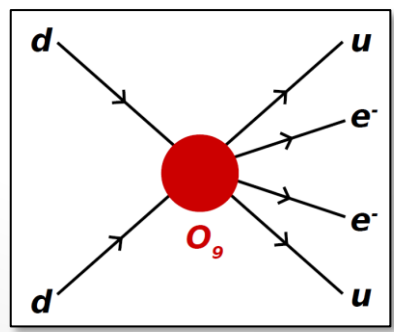

New Physics and $0\nu\beta\beta$

FFD, Graf, Iachello, Kotila, PRD 102 (2020)

- ▶ Limits on short-range operators
 - NMEs from IBM-2 with $g_A = 1.0$ and short-range correlations in Argonne parametrization

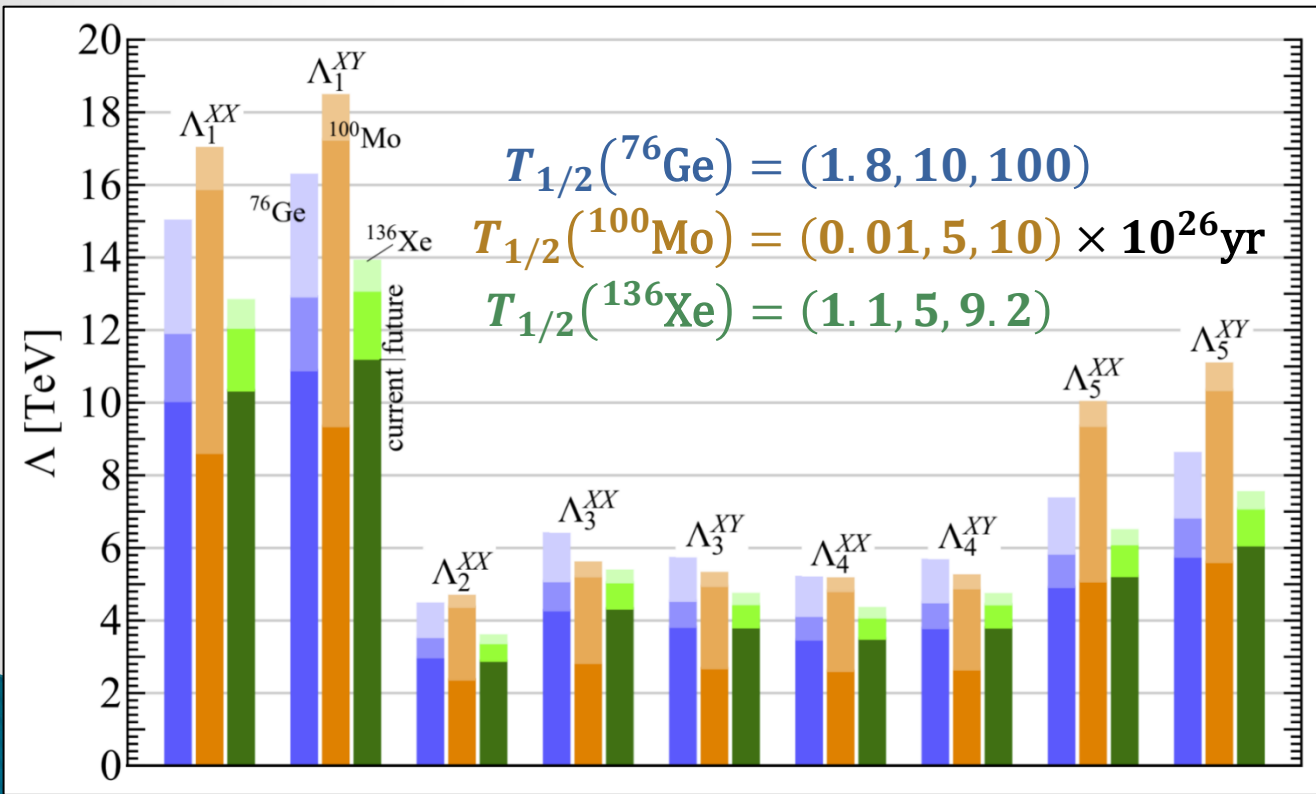
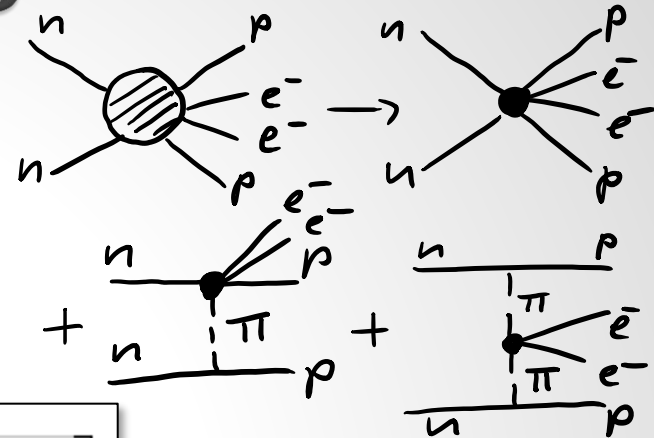

Pion-mediated contributions

- ▶ R-parity violating SUSY (Faessler, Kovalenko, Simkovic, Schwieger, Phys.Rev.Lett. 78 (1997) 183)
- ▶ Chiral EFT with Pion operators from Lattice QCD (Cirigliano, Dekens, de Vries, Graesser, Mereghetti, JHEP 1812 (2018) 097)

Impact on Baryogenesis

▶ Classic Example: High-Scale Leptogenesis

- Generation via heavy neutrino decays
- Competition with LNV washout processes
- Conversion to baryon asymmetry
 - EW sphaleron processes at $T \approx 100$ GeV
 - Observed asymmetry

$$\eta_B \equiv \frac{n_B - n_{\bar{B}}}{n_\gamma} = (6.20 \pm 0.15) \times 10^{-10}$$

▶ What if we observe lepton number violating processes in $0\nu\beta\beta$?

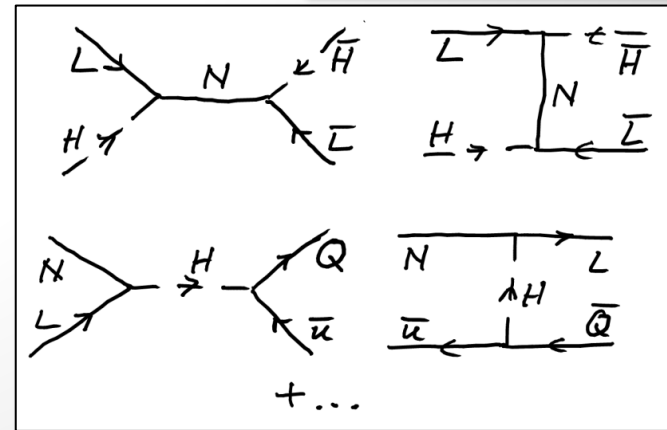
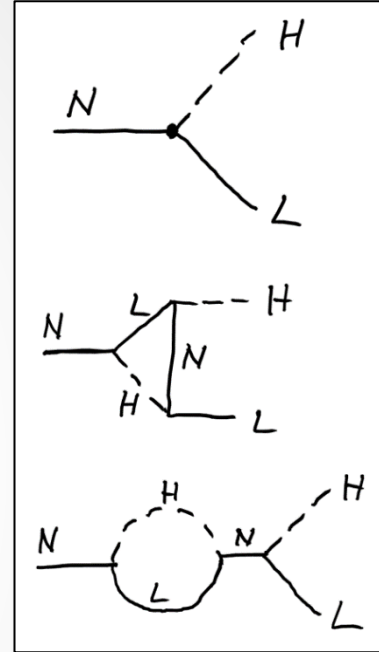
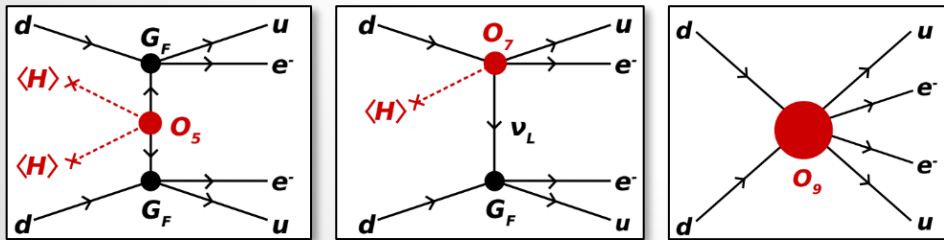

Impact on Baryogenesis

- ▶ Temperature ranges of strong equilibration
 - Assumes observation of corresponding process!
 - ▶ Observation of LNV
 - gives information at what temperatures operators are in equilibrium
 - **can falsify high-scale baryogenesis scenarios**
- FFD, Harz, Hirsch, Phys. Rev. Lett. 112 (2014) 221601, FFD, Harz, Hirsch, Huang, Päs, Phys.Rev.D 92 (2015) 3, 036005

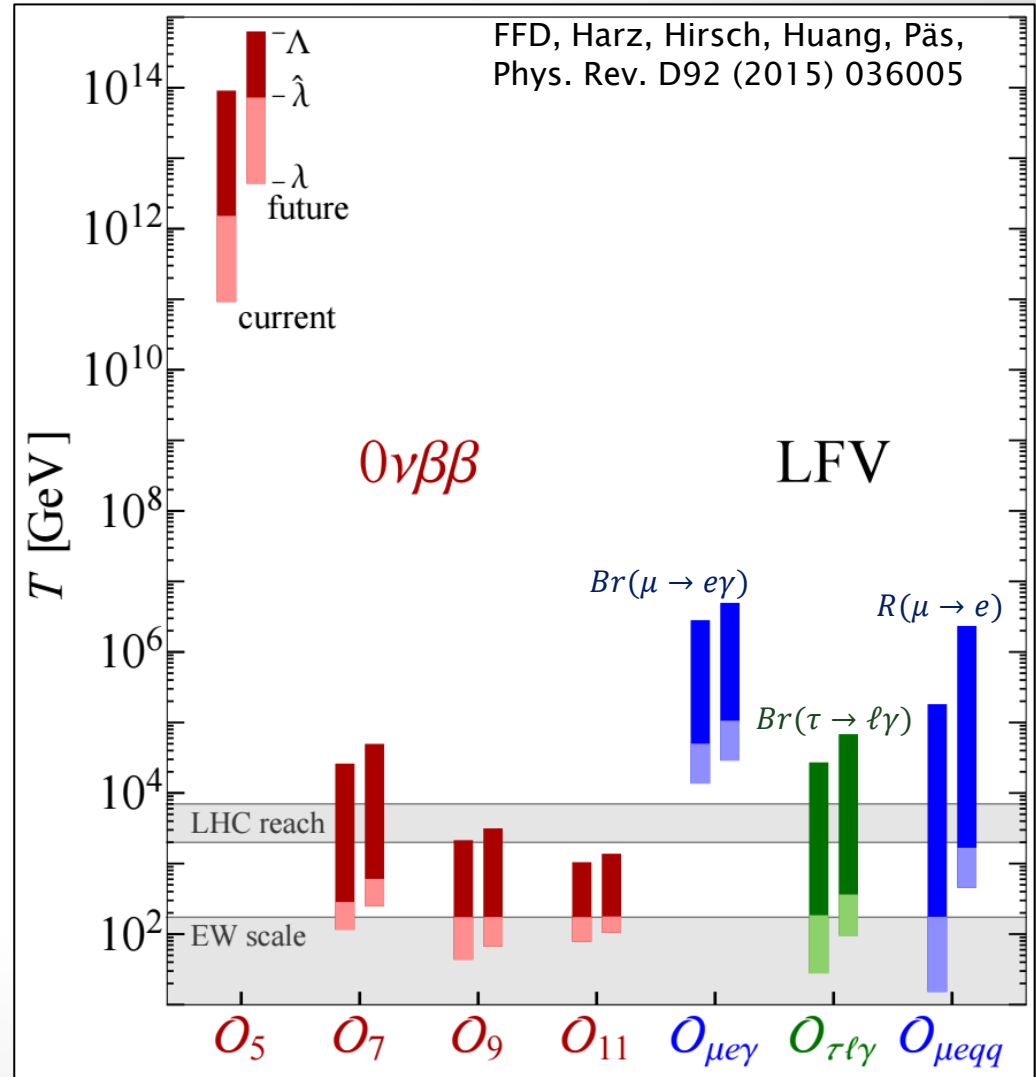

From Discovery to Mechanism

▶ Angular and energy distribution of emitted electrons

Doi et al. '83; Ali et al. '06; Arnold et al. '10; FFD, Jackson, Nasteva, Söldner-Rembold '10

- Most experiments only sensitive to total electron energy
- Tracking experiments (NEMO-3, SuperNEMO) have access to full kinematic information

$$\frac{d\Gamma}{dE_{e_1} dE_{e_2} d\cos\theta} = A(E_{e_1}, E_{e_2}) (1 - k(E_{e_1}, E_{e_2}) \cos\theta) \quad -1 \leq k(E_{e_1}, E_{e_2}) \leq 1$$

depends on mechanism

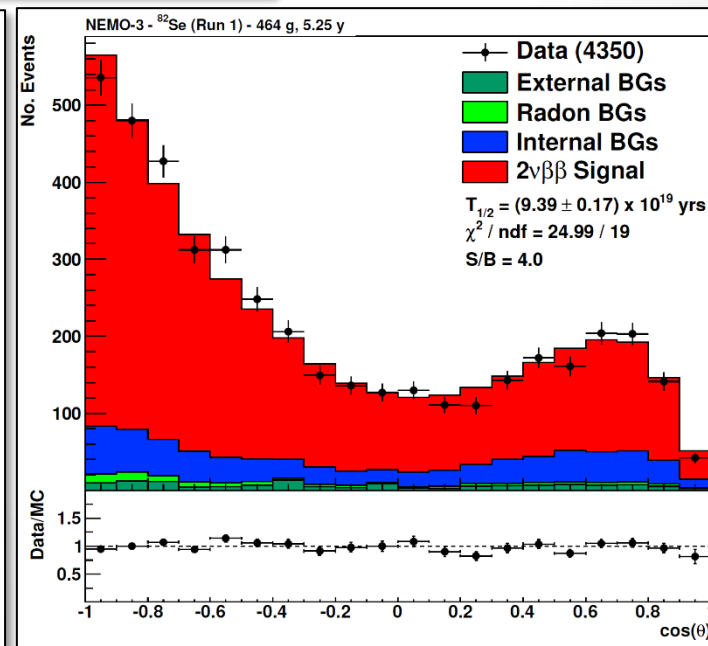
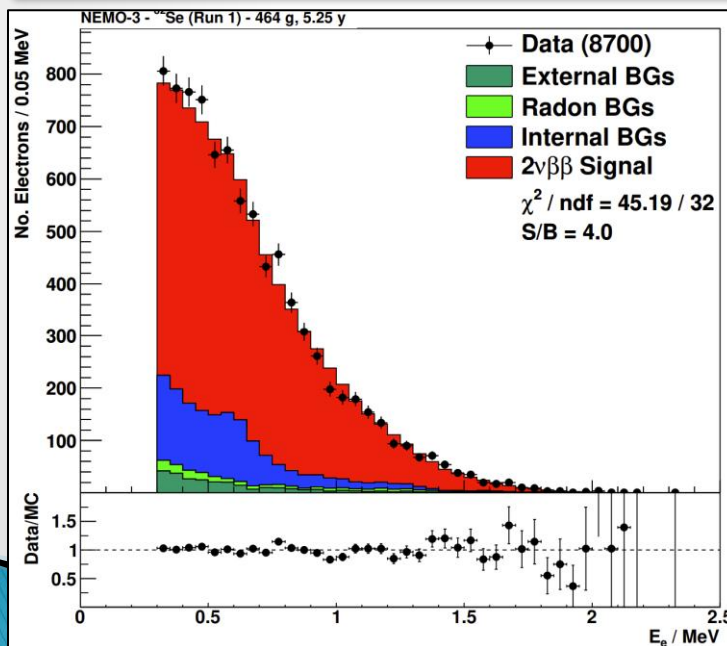

Nemo-3,
EPJC 78
(2018) 821

From Discovery to Mechanism

▶ Comparison of $0\nu\beta\beta$ in multiple isotopes

FFD, Päs, Phys. Rev. Lett. 98 (2007) 232501

- NMEs depend on $0\nu\beta\beta$ mechanism
- Ratio of half-lives in different isotopes as fingerprint of mechanism

$$\frac{T_{1/2}(X)}{T_{1/2}(Y)} = \frac{G(Y)|M(Y)|^2}{G(X)|M(X)|^2}$$

▶ Incorporate experimental and theory uncertainties

Agostini, FFD, Van Goffrier, JHEP 02 (2023) 172

- Feasible to distinguish mechanisms at two/three future experiments with different isotopes

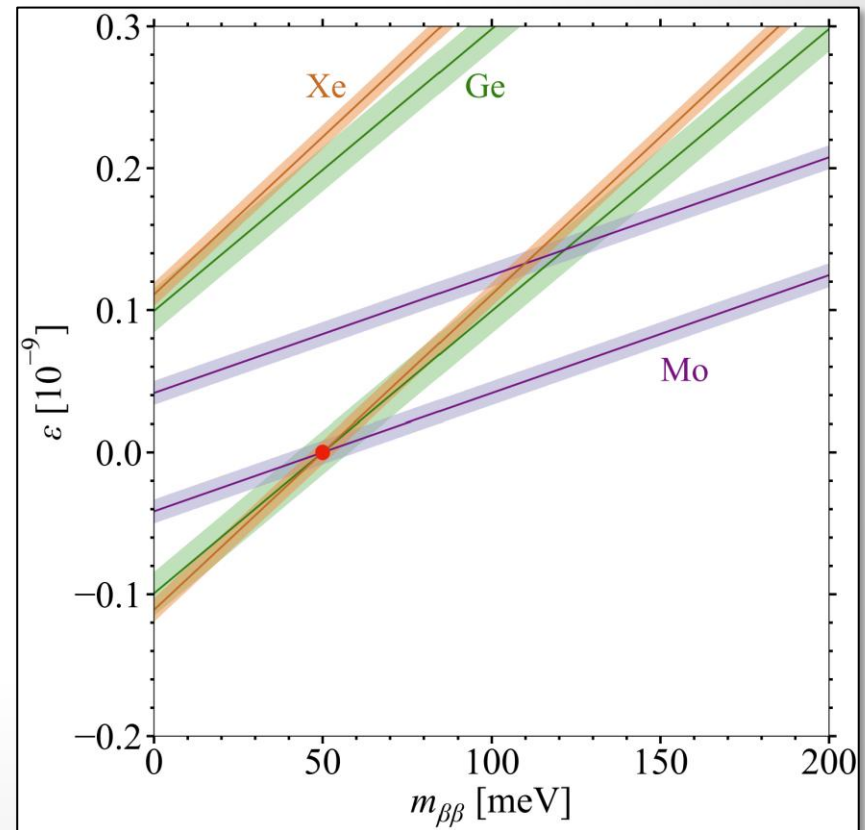

From Discovery to Mechanism

- ▶ Effective $0\nu\beta\beta$ Mass
 - Next generation experiments probing IO scenario
 - Pathways to explore NO scenario, e.g. JUNO loaded with $100 \text{ t}^{\text{nat}}_{\text{Te}}$
- ▶ Concordance or tension with other neutrino mass measurements
 - Cosmology
 - Tritium decay

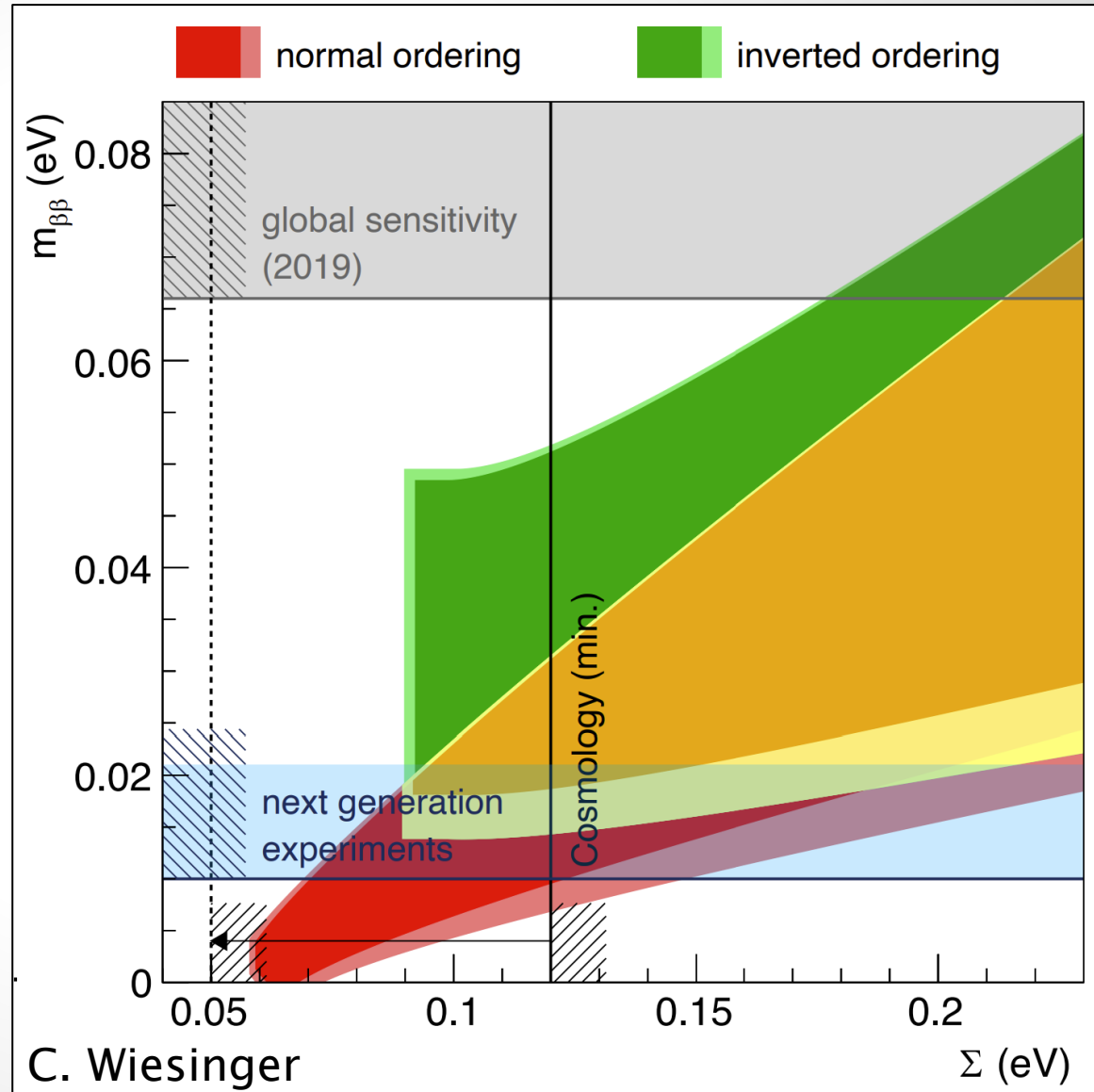

Conclusion

▶ Neutrino conundrum

- Much lighter than other fermions
- Only neutral fermions: Dirac or Majorana?
- Large flavour mixing different from quarks

▶ Absolute neutrino mass and nature

- Tritium decay and cosmological observations to probe last mass parameter of SM
- $0\nu\beta\beta$ as crucial test of neutrino nature and lepton number symmetry of SM
- $0\nu\beta\beta$ sensitive to high-scale lepton number violating New Physics up to GUT scales

▶ Portal to New Physics

- Mechanism of neutrino mass generation
- Exotic neutrino interactions and light NP in $2\nu\beta\beta$

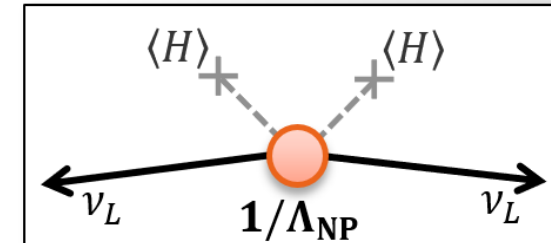

$$\frac{T_{1/2}^{0\nu\beta\beta}}{10^{28} \text{ y}} \approx \left(\frac{\Lambda_{NP}}{10^{15} \text{ GeV}} \right)^2$$