



基于手征有效场论的强子物理研究进展

De-Liang Yao

Hunan University

第五届强子与重味物理理论与实验联合研讨会

Shijiazhuang, 27-31 Mar. 2026

- Introduction
- Recent progress in hadron physics with chiral effective field theory
 - ▶ High-order calculation beyond one-loop
 - ▶ Interplay with dispersion relations
 - ▶ New physics
 - ▶ Generalisation to heavy matter fields
- Summary and outlook

Chiral Perturbation Theory—EFT of QCD at low energies

- **Facets of QCD** — Asymptotic freedom & Color confinement

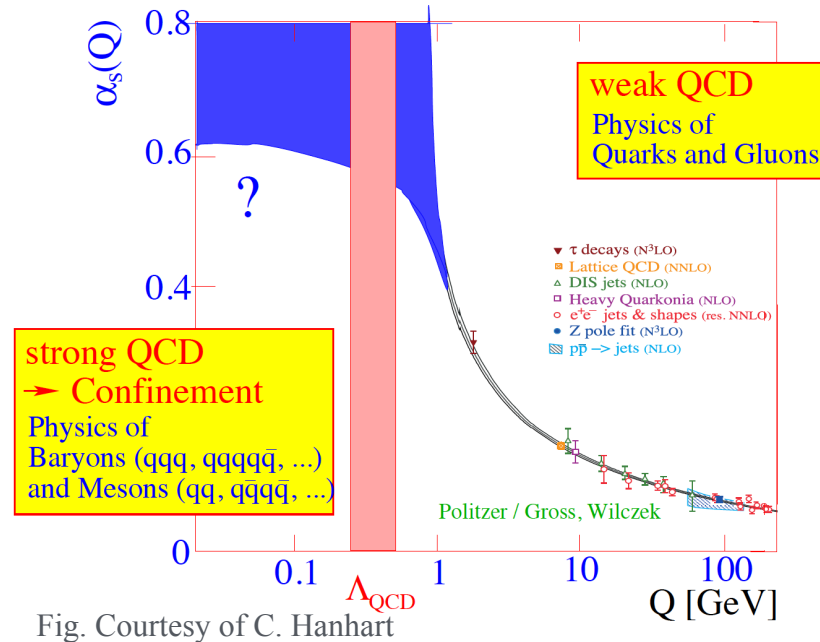

Standard Model of Elementary Particles

		three generations of matter (fermions)				
		I	II	III		
QUARKS	mass	≈2.4 MeV/c ²	≈1.275 GeV/c ²	≈172.44 GeV/c ²	0	≈125.09 GeV/c ²
	charge	2/3	2/3	2/3	0	0
	spin	1/2	1/2	1/2	1	0
		u up	c charm	t top	g gluon	H Higgs
		d down	s strange	b bottom	γ photon	
		e electron	μ muon	τ tau	Z Z boson	
LEPTONS	mass	≈0.511 MeV/c ²	≈105.67 MeV/c ²	≈1.7768 GeV/c ²	≈91.19 GeV/c ²	
	charge	-1	-1	-1	0	0
	spin	1/2	1/2	1/2	1	1
	ν_e electron neutrino	ν_μ muon neutrino	ν_τ tau neutrino	W W boson		
					SCALAR BOSONS	
					GAUGE BOSONS	

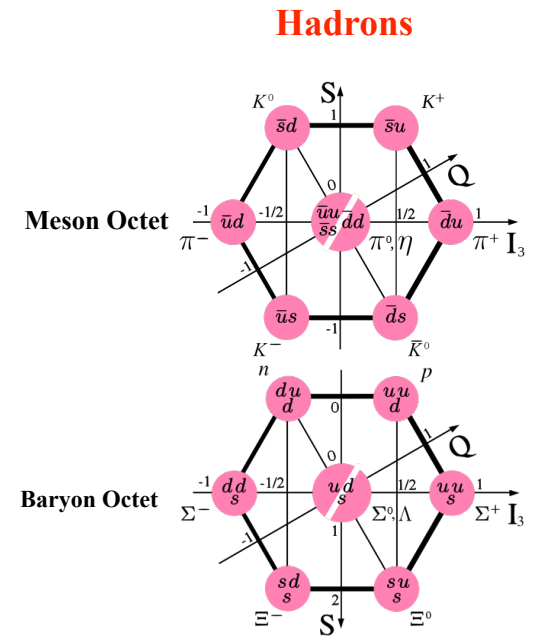

- **Low-energy region** — Quarks are glued together by gluons to form hadrons

Lattice QCD

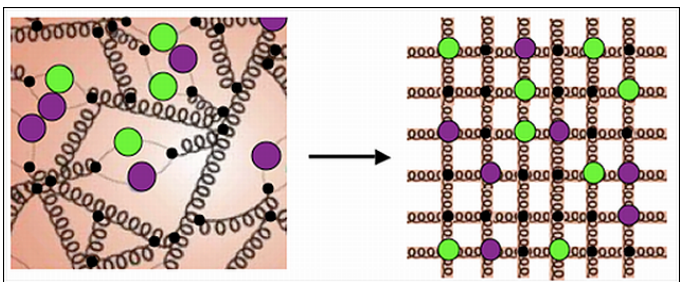

Phenomenological Models

- Linear Sigma Model
- Nambu-Jona-Lasinio Model
- Jülich Model
- ...

Effective Field Theories



- **Chiral Perturbation theory (ChPT)**
- ➔ hadron fields as degrees of freedom
- ➔ Expansion in masses and external momenta

We are entering the era of EFTs

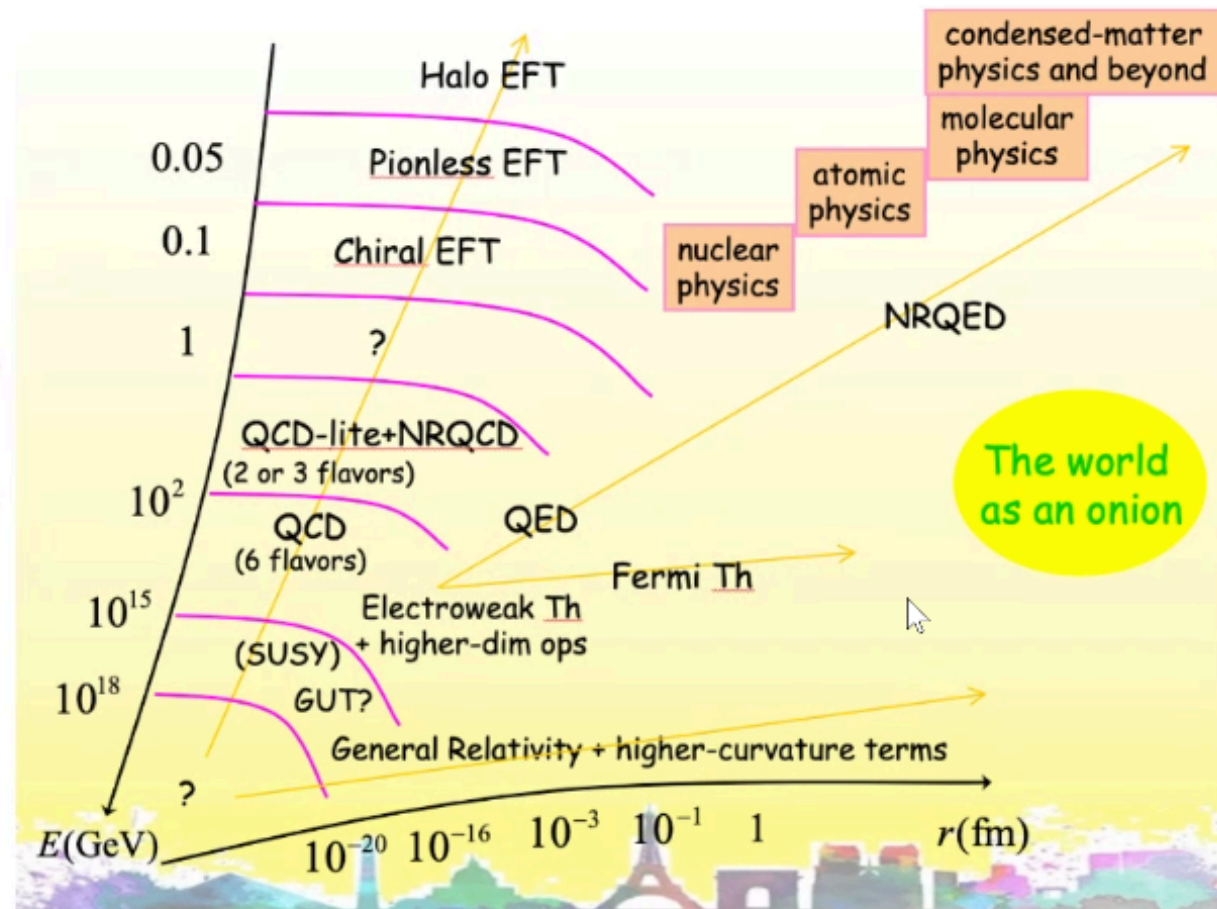
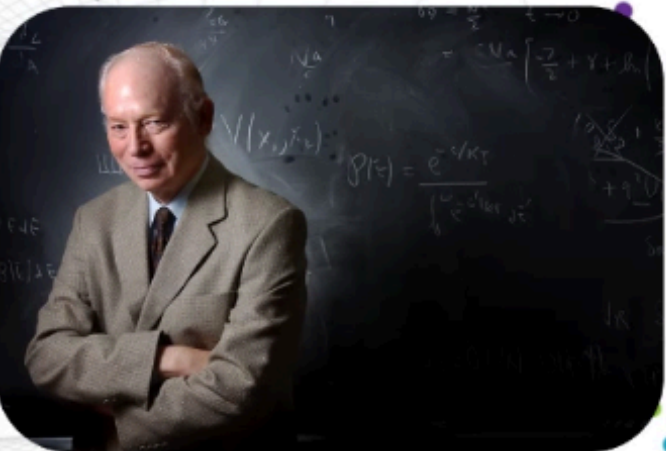

“Now, considering the fact that experiments can probe only a **limited range of energies**, it seems natural to **take EFT** as a general framework for analyzing experimental results.”

T. Y. Cao

in *Renormalization, From Lorentz to Landau (and Beyond)*, L.M. Brown (ed.), 1993



Importance of EFT

- **Towards faithful scattering amplitudes**

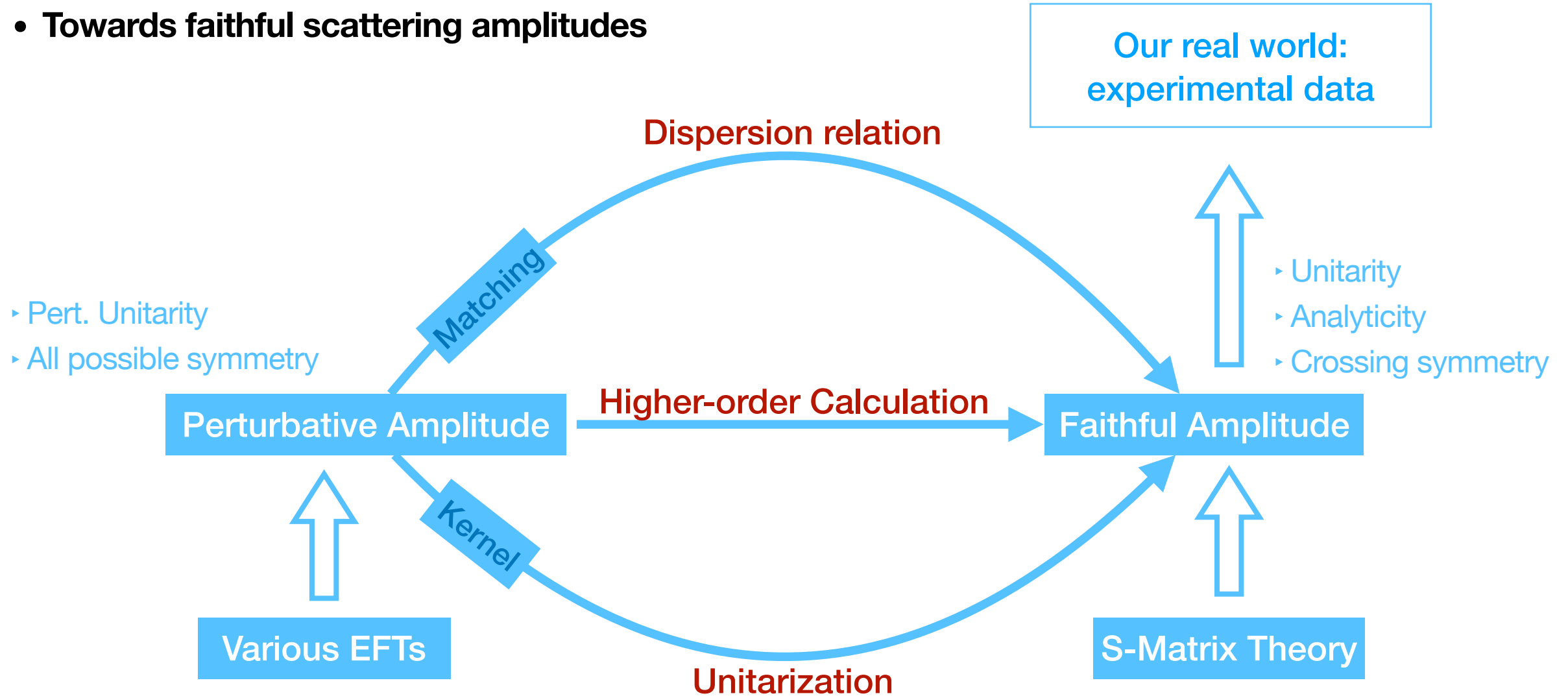

ChPT beyond one-loop

- Time line

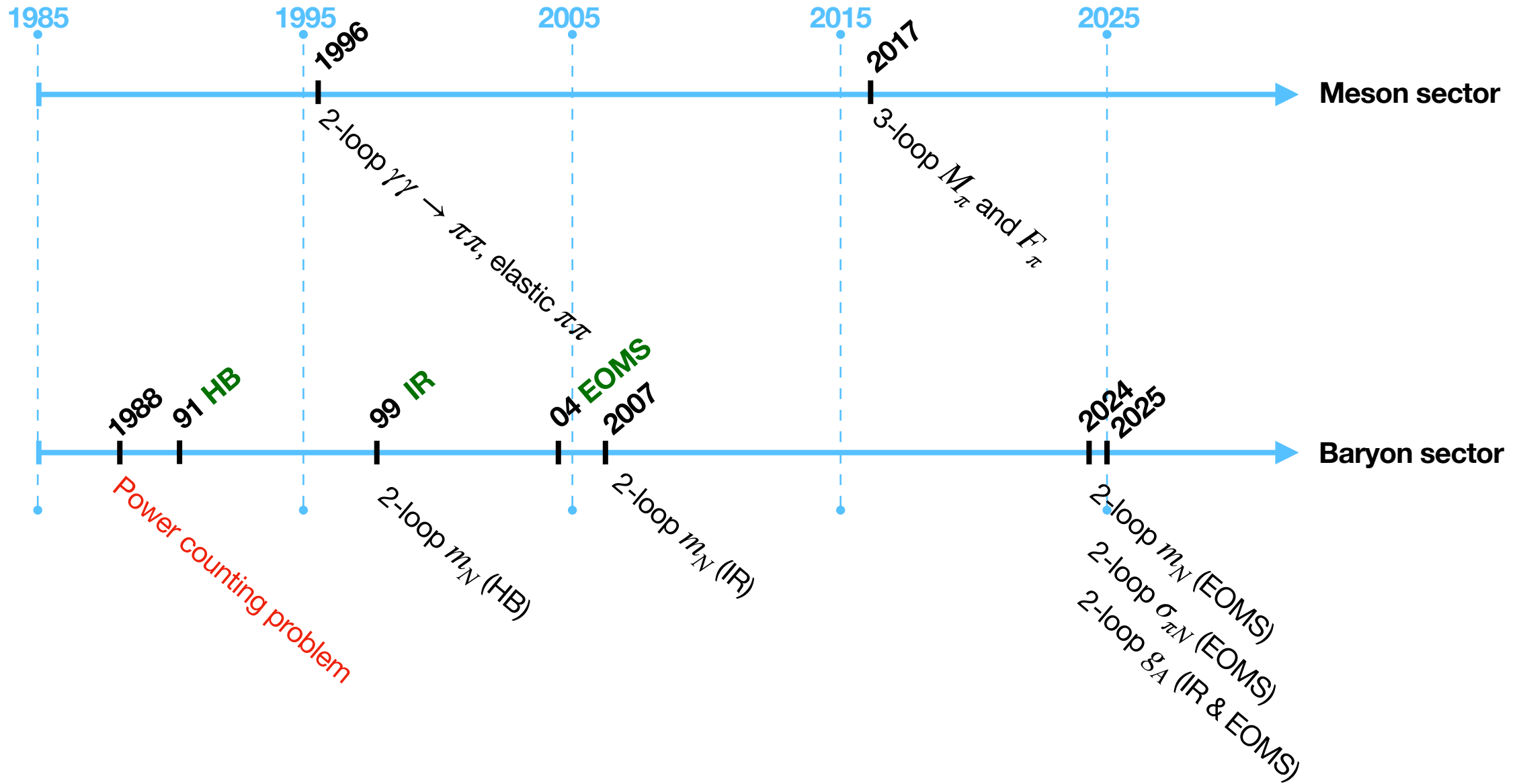

I. High-order calculations beyond one-loop

Nucleon mass physics

- High precision determination of the nucleon mass
 - The proton mass decomposition
 - Sigma term: tension between lattice QCD and phenomenological results
 - WIMP dark matter: scalar coupling of the nucleon to dark matter
 - ...

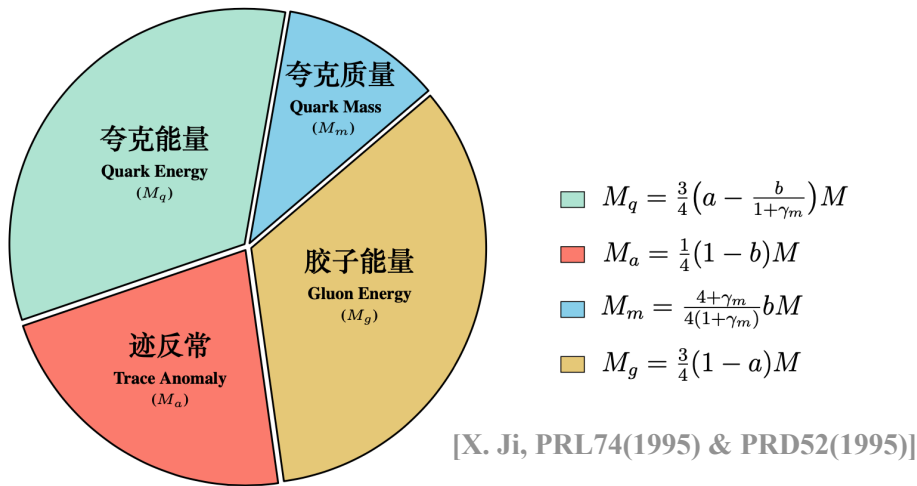

Feynman – Hellmann Theorem

$$\sigma_{\pi N} = \frac{\hat{m}}{2m_N} \langle N | \bar{u}u + \bar{d}d | N \rangle = M_\pi^2 \frac{\partial m_N}{\partial M_\pi^2}$$

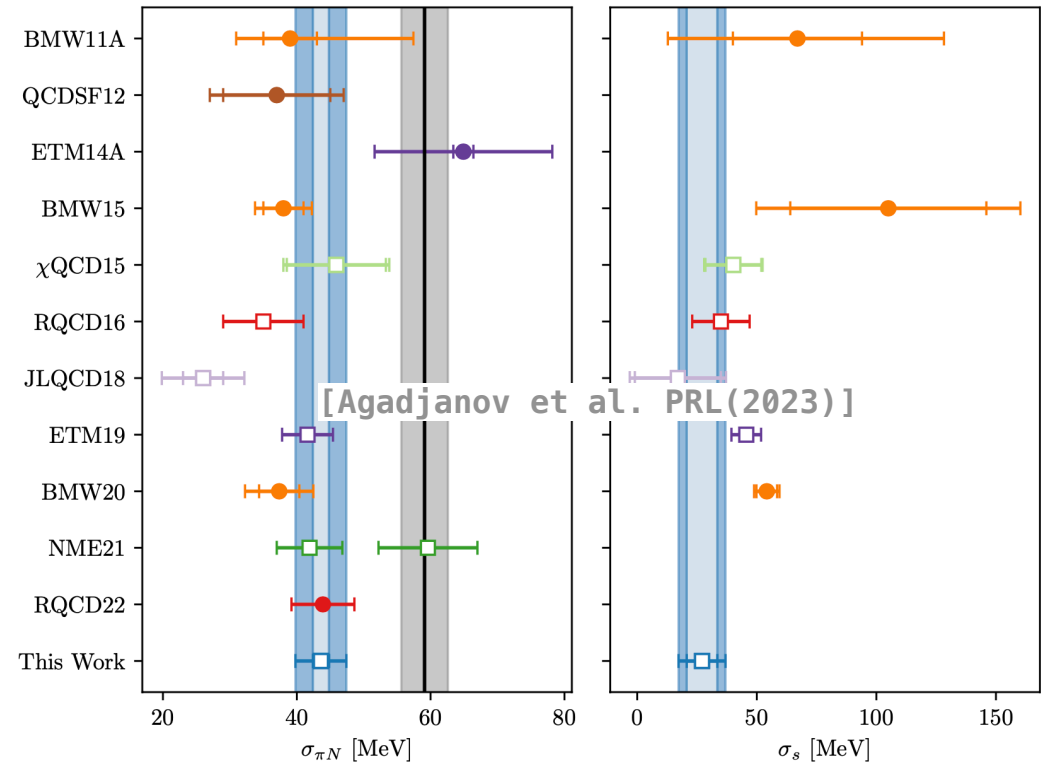

The nucleon mass at two-loop order

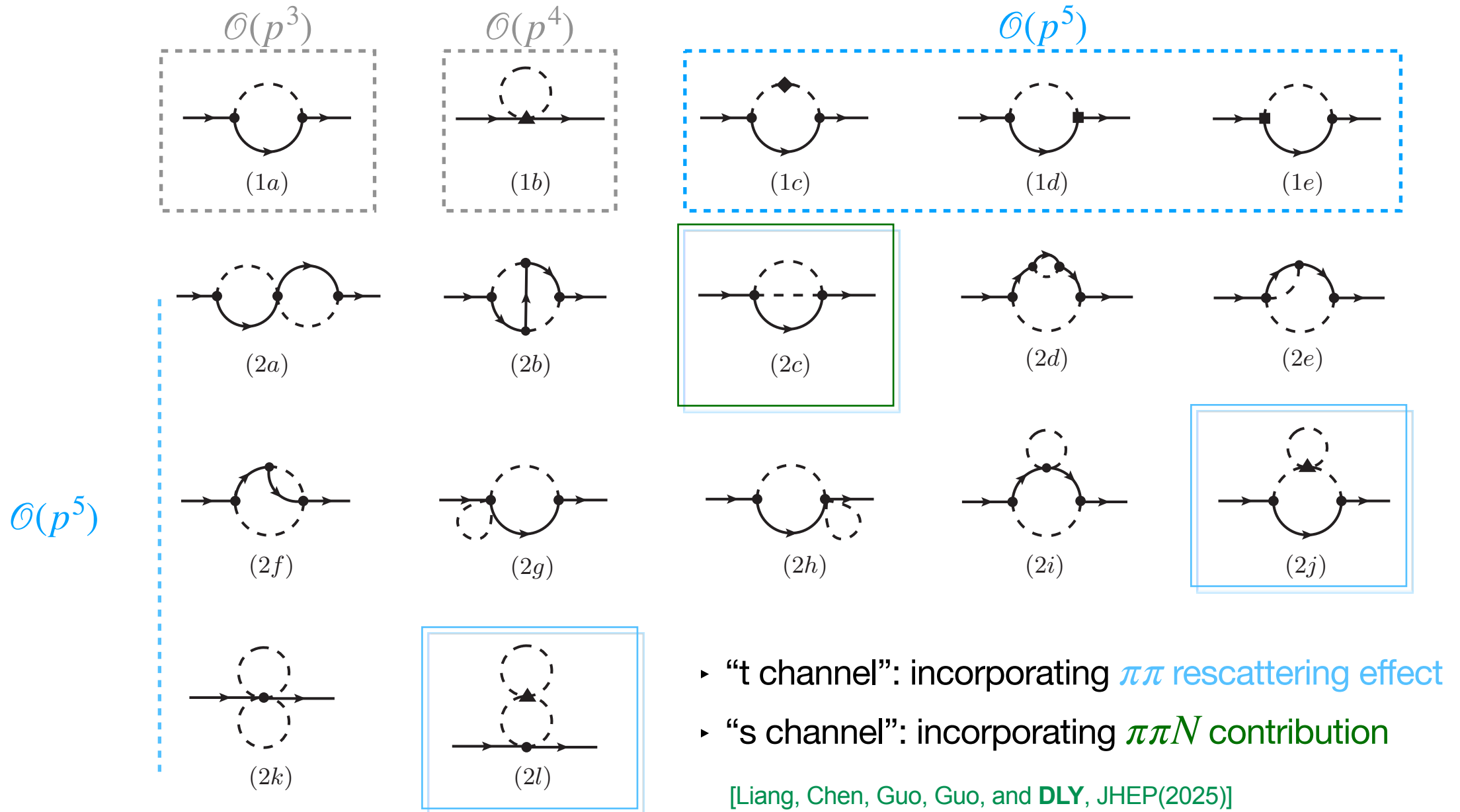

- ▶ “t channel”: incorporating $\pi\pi$ rescattering effect
- ▶ “s channel”: incorporating $\pi\pi N$ contribution

[Liang, Chen, Guo, Guo, and DLY, JHEP(2025)]

Two-loop chiral extrapolation

- Assess the convergency of the chiral expansion

[Z.-R. Liang, H.-X. Chen, F.-K. Guo, Z.-H. Guo, and **DLY**, JHEP04 (2025)]

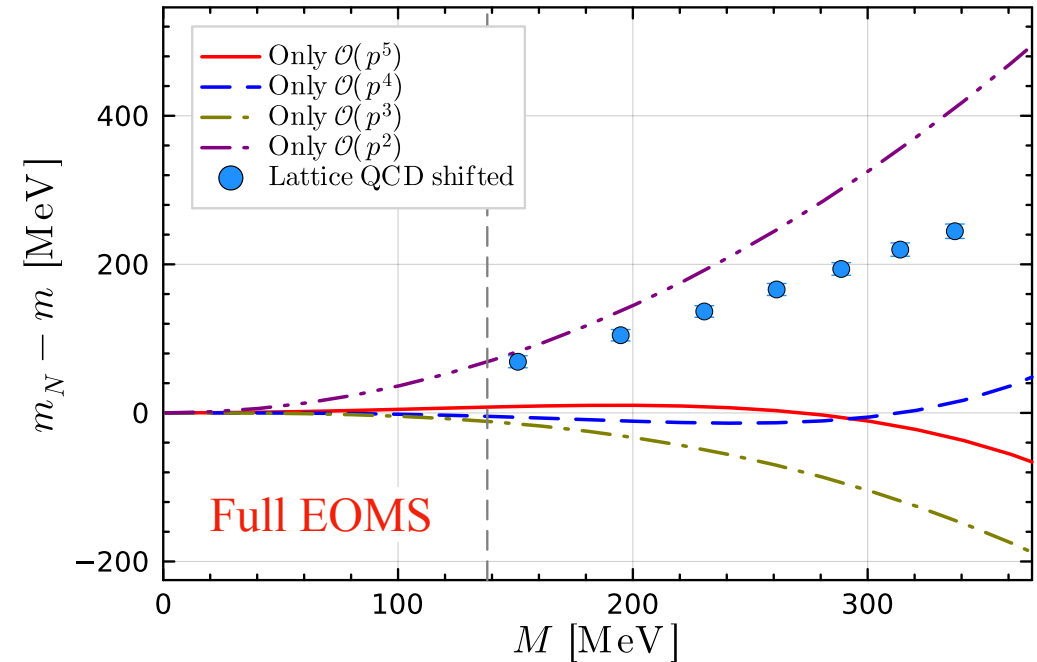
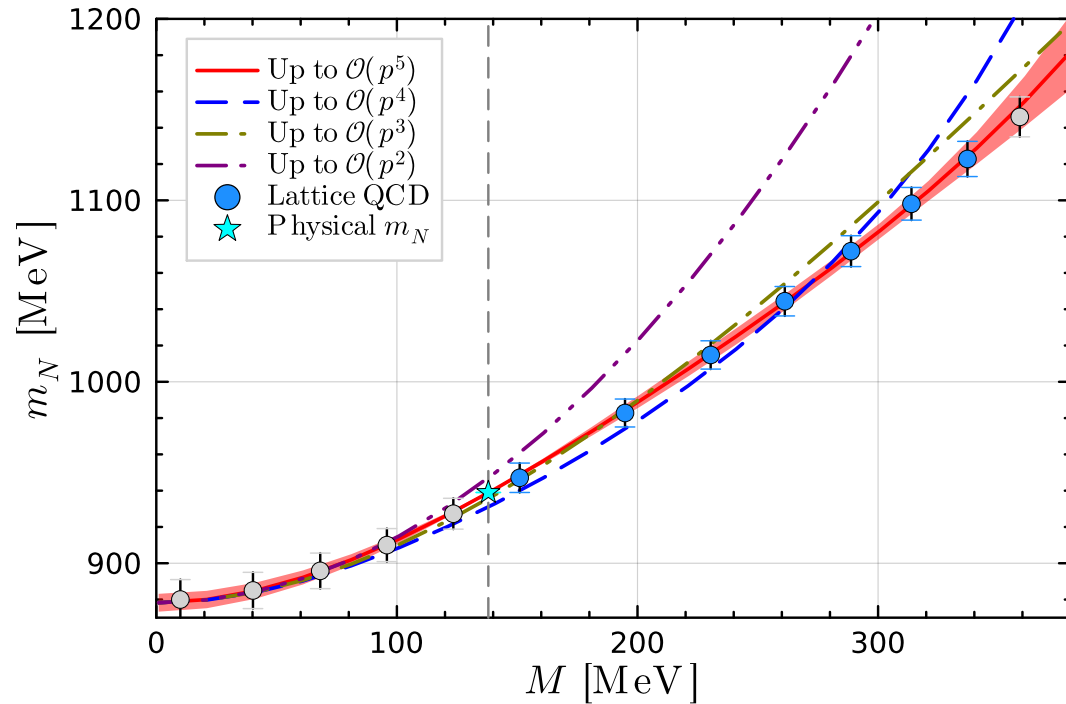

- Two-loop contribution is small, approximately 10 MeV, for pion mass < 300 MeV;

Nucleon sigma term

- Sigma term via Feynman-Hellman theorem

[Z.-R. Liang, H.-X. Chen, F.-K. Guo, Z.-H. Guo, and **DLY**, arXiv:2508.11435 [hep-ph]]

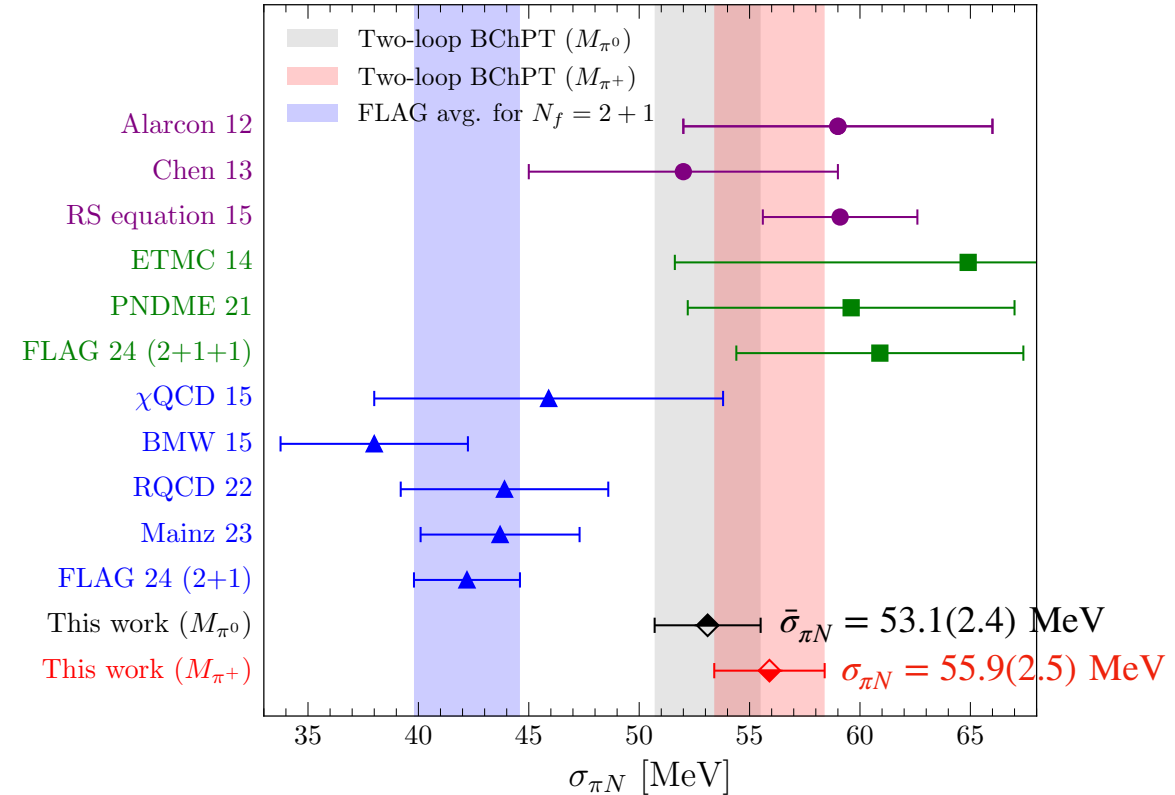
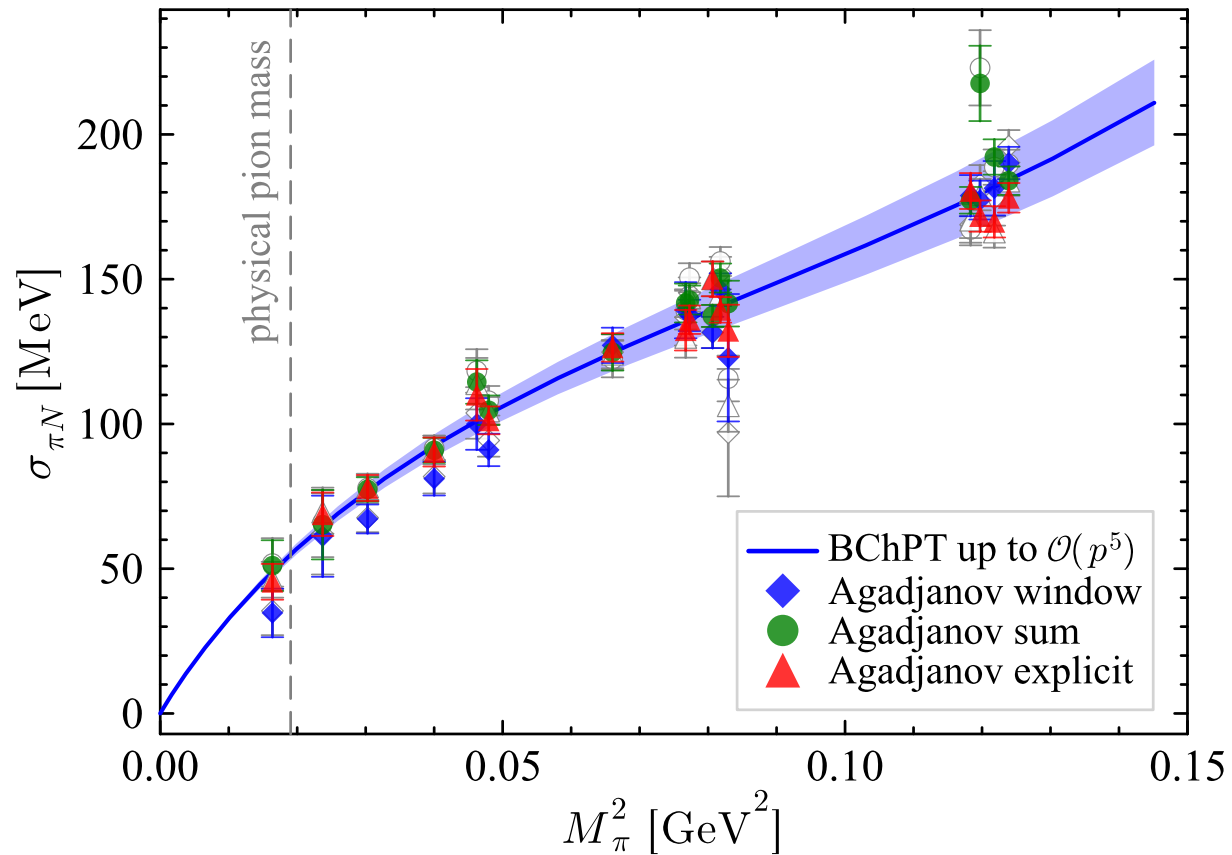

Resolving the tension between lattice QCD and phenomenology!

➔ See talk by 梁泽锐 for more details

II. Interplay with Dispersion Relations

Gravitational structure of hadrons

- Probes of hadron structure (nucleon as example)

em: $\partial_\mu J_{\text{em}}^\mu = 0$	$\langle N' J_{\text{em}}^\mu N \rangle \longrightarrow$	$Q = 1.602176487(40) \times 10^{-19} \text{C}$ $\mu = 2.792847356(23) \mu_N$
weak: PCAC	$\langle N' J_{\text{weak}}^\mu N \rangle \longrightarrow$	$g_A = 1.2694(28)$ $g_p = 8.06(55)$
gravity: $\partial_\mu T_{\text{grav}}^{\mu\nu} = 0$	$\langle N' T_{\text{grav}}^{\mu\nu} N \rangle \longrightarrow$	$m = 938.272013(23) \text{ MeV}/c^2$ $J = \frac{1}{2}$ $D = ?$

Polyakov & Schweitzer, IJMPA (2018) 1830025

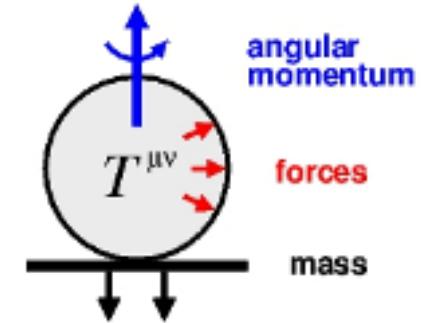

D-term: "Last unknown global property"

- Gravitational structure

- ▶ Gravity couples to matter via QCD energy-momentum tensor (EMT)

- ▶ Impractical probe by scattering off gravitons

✓ Nucleon as targets: accessible by hard-exclusive reactions like DVCS via GPDs

✓ Pions: GPDs \rightarrow GDAs by crossing

✓ Lattice QCD

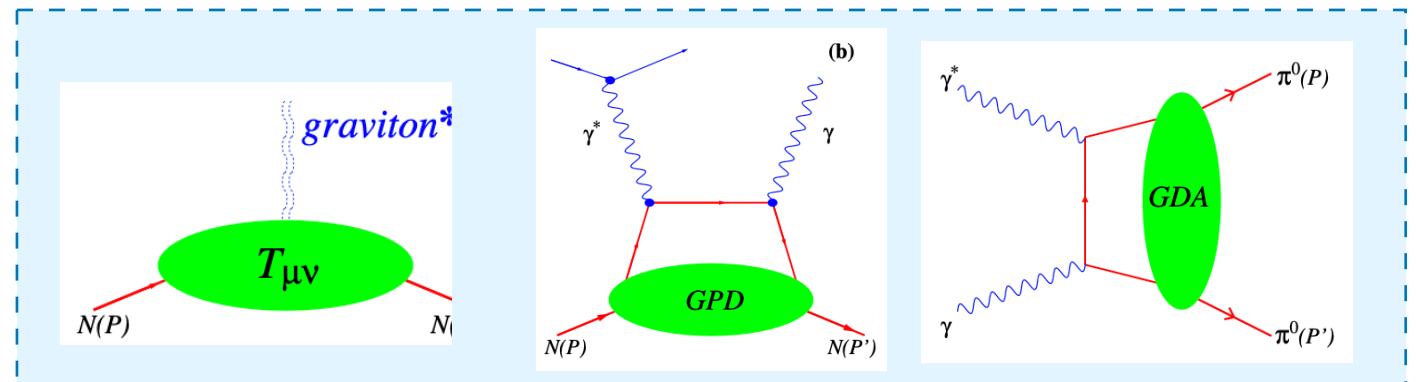

Unitarity relation for nucleon GFFs

- Discontinuity

$$\text{Disc} \langle N(p') \bar{N}(p) | \hat{T}^{\mu\nu}(0) | 0 \rangle \propto \sum_n \langle N(p') \bar{N}(p) | n \rangle \langle n | \hat{T}^{\mu\nu}(0) | 0 \rangle^* \delta^4(p + p' - p_n)$$

- In the region $t \in (t_\pi, 16t_\pi)$, only $\pi\pi$ intermediate state

Dispersion relations:

$$(A, J, \Theta)(t) = \frac{1}{\pi} \int_{4m_\pi^2}^{\infty} dt' \frac{\text{Im}(A, J, \Theta)(t')}{t' - t}$$

$$\frac{1}{\pi} \int_{4m_\pi^2}^{\infty} dt' \frac{\text{Im}(A, J, \Theta)(t')}{t'} = \left(1, \frac{1}{2}, m_N\right)$$

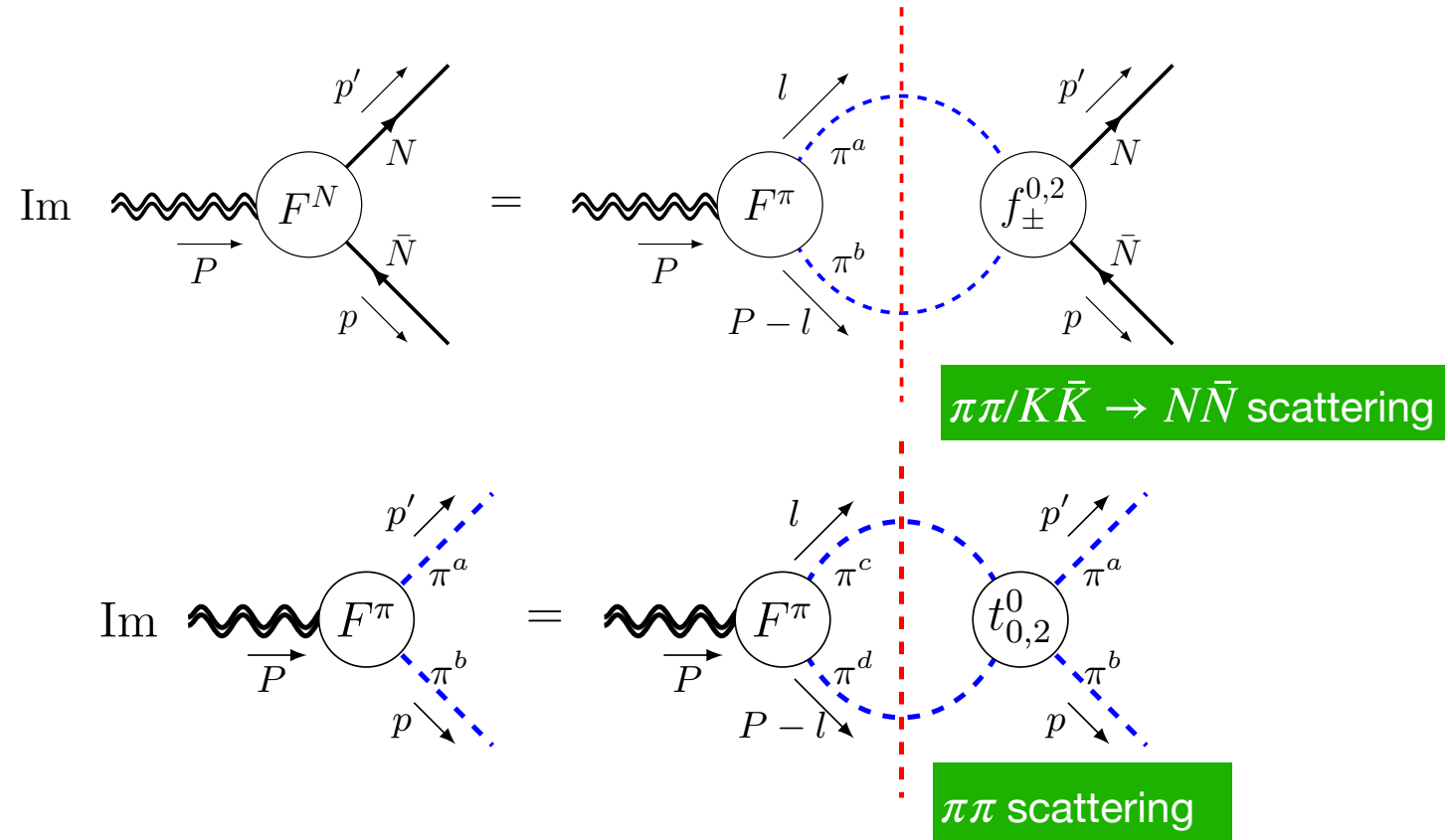



Nucleon GFFs

Predictions:

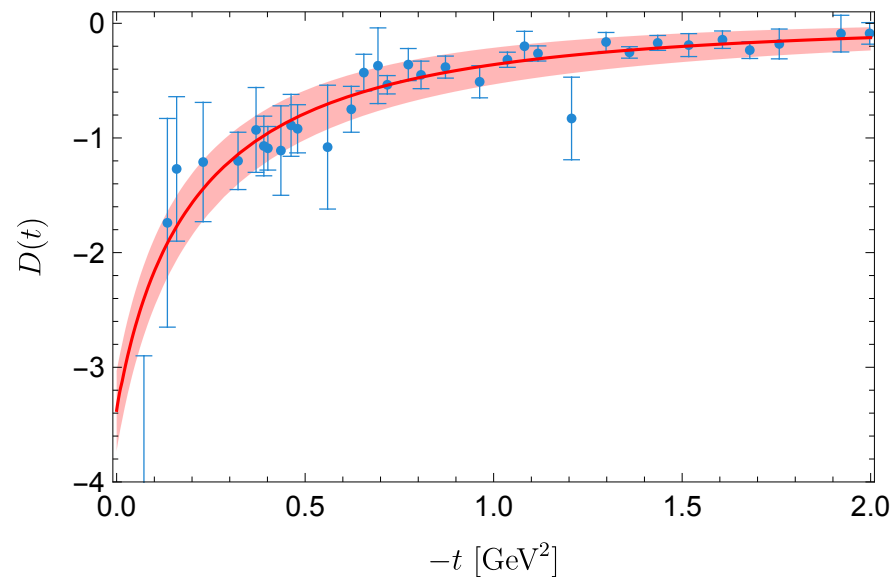
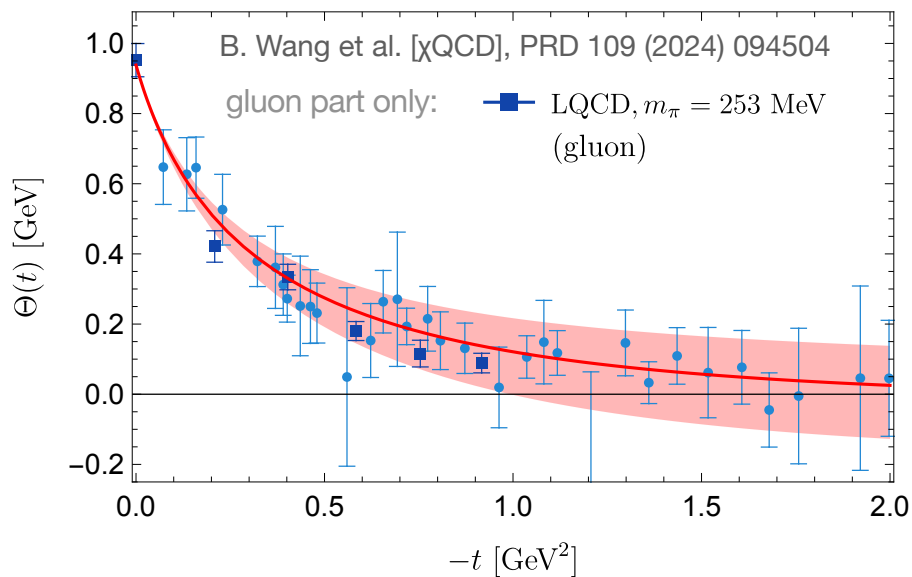
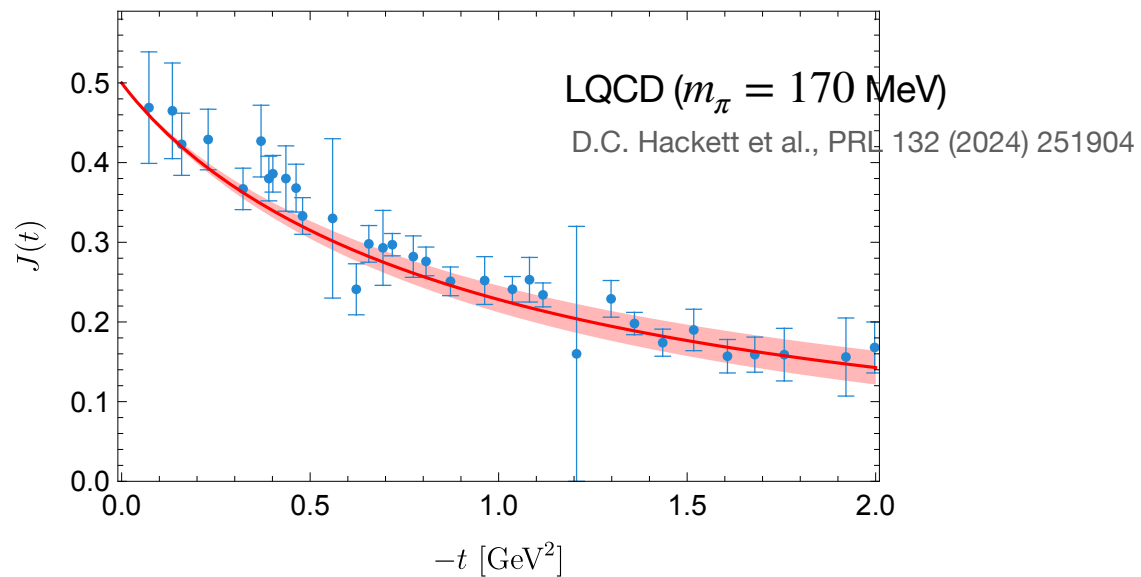
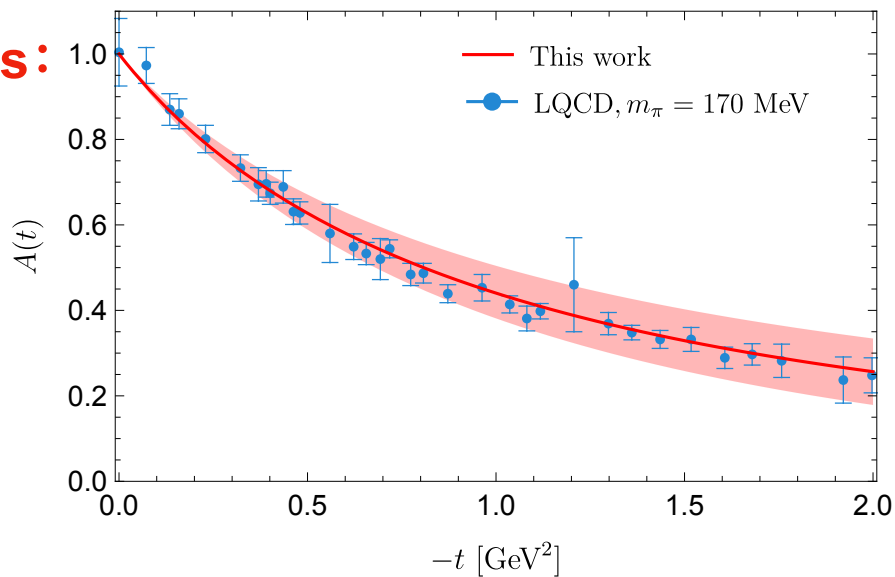

[X.-H. Cao, F.-K. Guo, Q.-Z. Li and **DLY**, Nature Communications (2025)]

Nucleon GFFs: D-term & radii

- D-term: $D \equiv D(0)$

- **Various radii in the Breit frame**

- ▶ From the trace FF:

$$\langle r_{\Theta}^2 \rangle = 6A'(0) - \frac{9D}{2m_N^2}$$

- ▶ Radius of energy density:

$$\langle r_{\text{Ener}}^2 \rangle = 6A'(0) - \frac{3D}{2m_N^2}$$

- ▶ Mechanical radius

$$\langle r_{\text{Mech}}^2 \rangle = \frac{6D}{\int_{-\infty}^0 dt D(t)}$$

- ▶ Radius of the density $J(t) + \frac{2}{3}t \frac{d}{dt} J(t)$

$$\langle r_J^2 \rangle = 20J'(0)$$

Quantity	Result	Error budget
D-term	$-3.38^{+0.34}_{-0.35}$	$+(0.18)_{\text{ChPT}}(0.12)_{\text{PWA}}(0.26)_{\text{eff}}$ $-(0.16)_{\text{ChPT}}(0.12)_{\text{PWA}}(0.29)_{\text{eff}}$
$\langle r_{\Theta}^2 \rangle$ [fm]	$0.97^{+0.03}_{-0.03}$	$+(0.01)_{\text{ChPT}}(0.01)_{\text{PWA}}(0.03)_{\text{eff}}$ $-(0.02)_{\text{ChPT}}(0.01)_{\text{PWA}}(0.26)_{\text{eff}}$
$\langle r_{\text{Ener}}^2 \rangle$ [fm]	$0.70^{+0.03}_{-0.04}$	$+(0.02)_{\text{ChPT}}(0.01)_{\text{PWA}}(0.02)_{\text{eff}}$ $+(0.02)_{\text{ChPT}}(0.01)_{\text{PWA}}(0.03)_{\text{eff}}$
$\langle r_{\text{Mech}}^2 \rangle$ [fm]	$0.72^{+0.09}_{-0.08}$	$+(0.02)_{\text{ChPT}}(0.00)_{\text{PWA}}(0.09)_{\text{eff}}$ $-(0.03)_{\text{ChPT}}(0.01)_{\text{PWA}}(0.07)_{\text{eff}}$
$\langle r_J^2 \rangle$ [fm]	$0.70^{+0.02}_{-0.02}$	$+(0.01)_{\text{ChPT}}(0.01)_{\text{PWA}}(0.01)_{\text{eff}}$ $-(0.01)_{\text{ChPT}}(0.00)_{\text{PWA}}(0.02)_{\text{eff}}$

- ▶ ChPT: NLO ChPT inputs
- ▶ paw: $\pi\pi/K\bar{K} \rightarrow N\bar{N}$
- ▶ eff: effective poles m_S, m_D

III. New physics

ChEFT and BSM physics

- EFT at various scales (e.g. Lepton number violation)

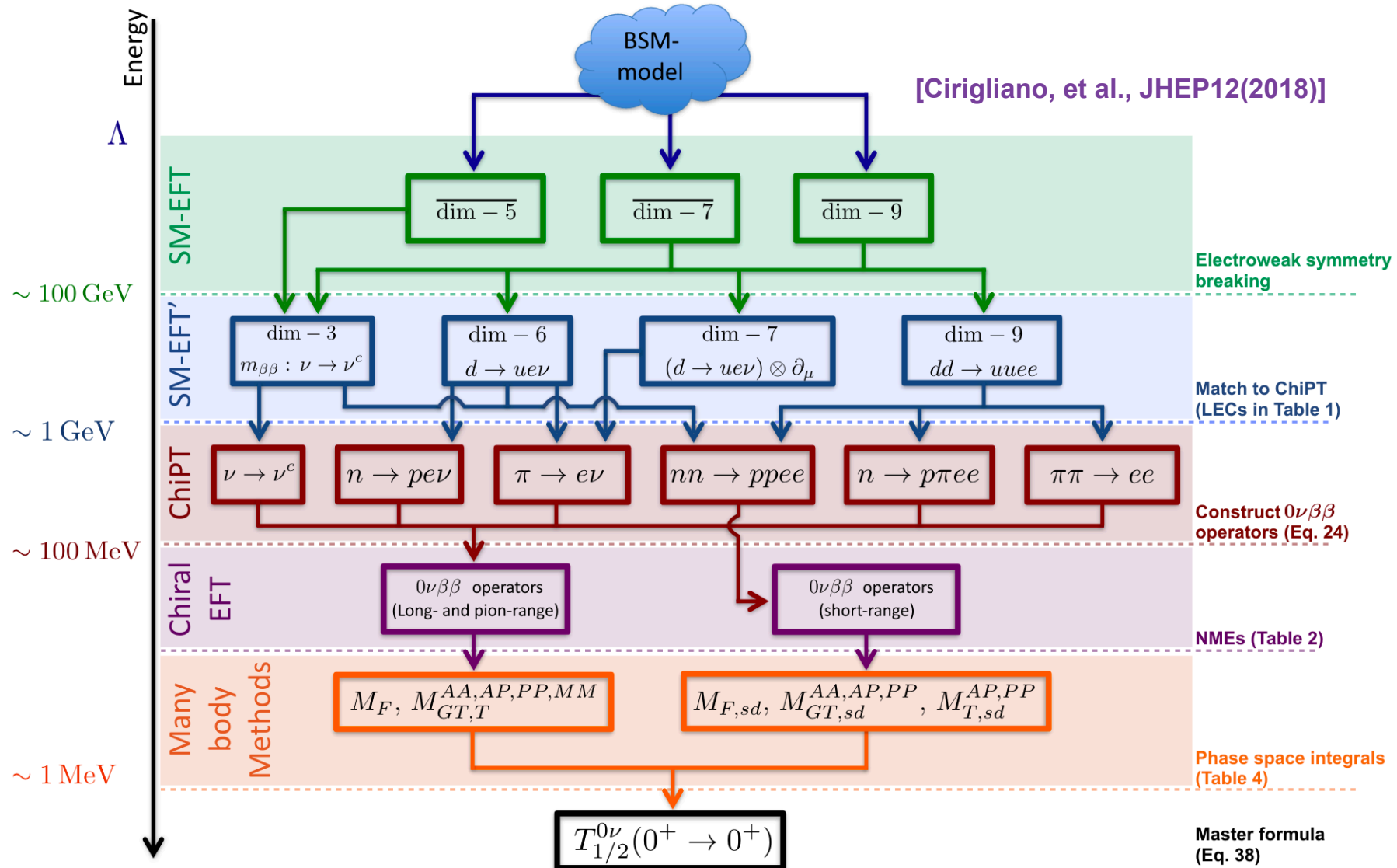

Hadronic neutrinoless double beta decay

- Nuclear $0\nu 2\beta$

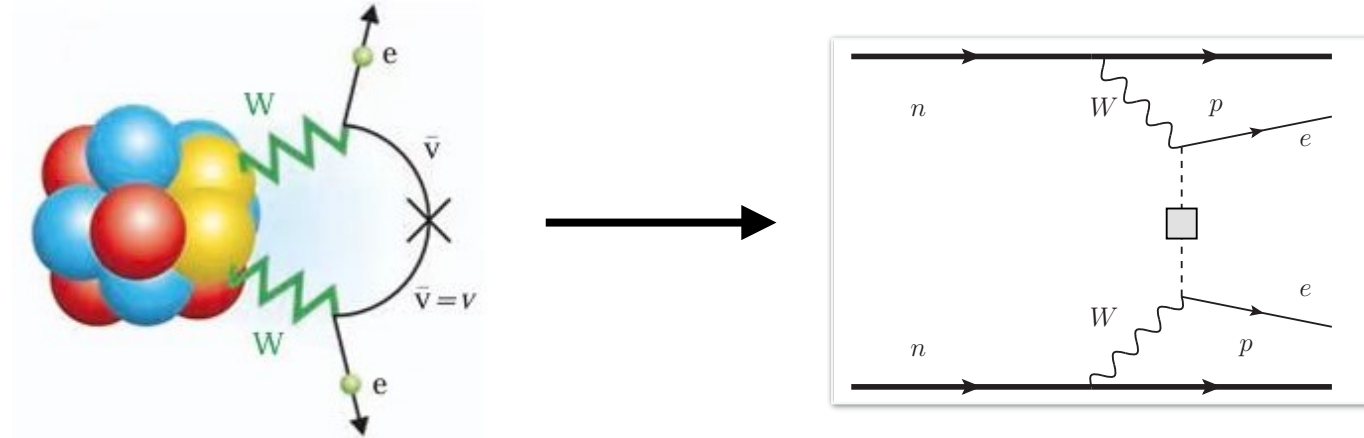

- Hadronic $0\nu 2\beta$?

- ▶ Kaons: $K^\pm \rightarrow \pi^\mp l_\alpha^\pm l_\beta^\pm$ [Liao, Ma and Wang, JHEP03(2020)]

- ▶ Hyperons

- $\Delta S = 0$: $\Sigma^- [dds] \rightarrow \Sigma^+ [uus] e^- e^-$;
- $\Delta S = 1$: $\Sigma^- [dds] \rightarrow p [duu] l^- l^-$, $\Xi^- [dss] \rightarrow \Sigma^+ [uus] e^- e^-$;
- $\Delta S = 2$: $\Xi^- [dss] \rightarrow p [duu] l^- l^-$.

Hadronic neutrinoless double beta decay

- **Hyperon $0\nu 2\beta$ in BChPT**

[Z.-Y. Zhao, Z.-R. Liang, F.-K. Guo, L.-P. He and **DLY**, arXiv:2602.08453 [hep-ph]]

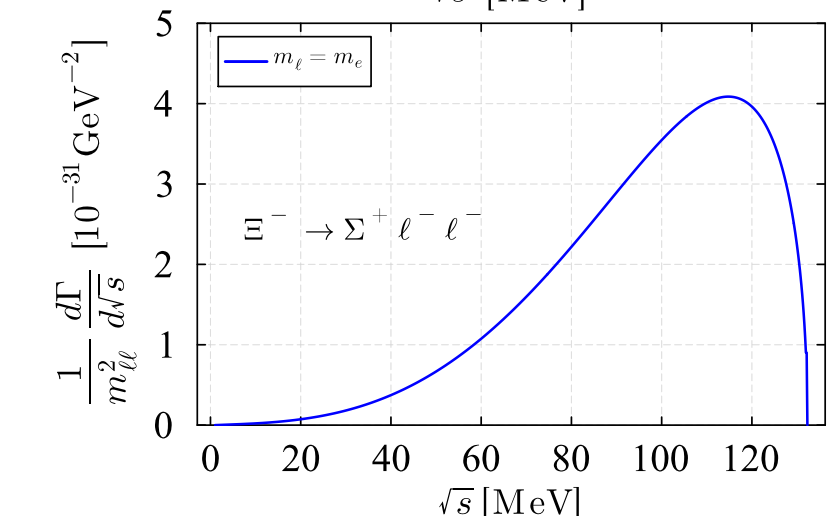
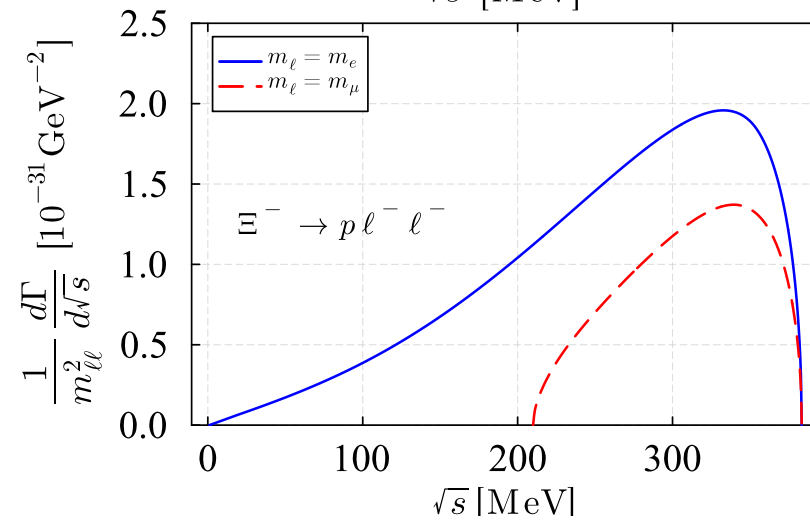
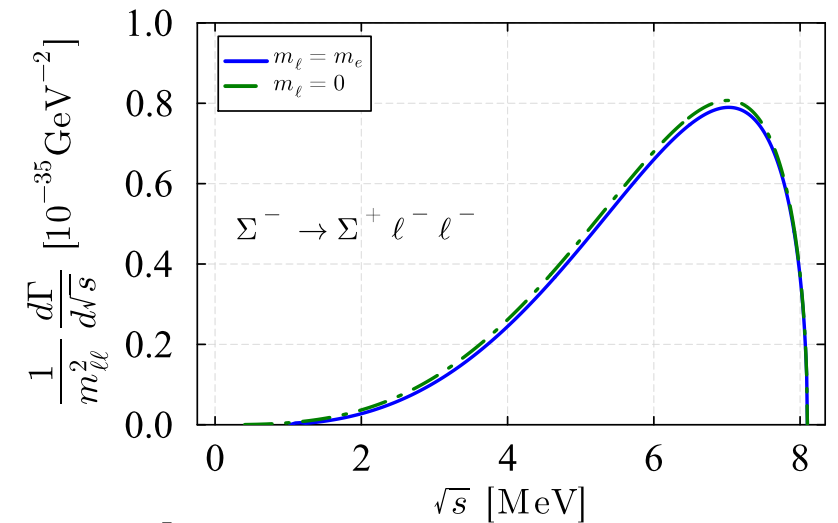
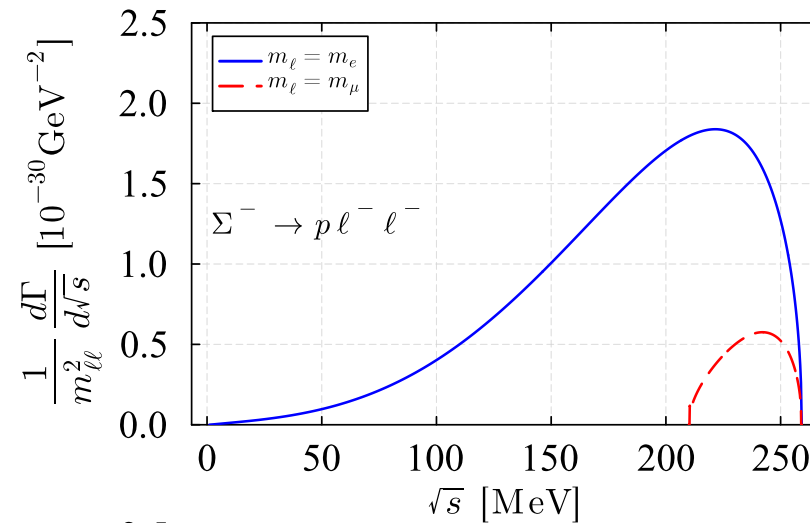
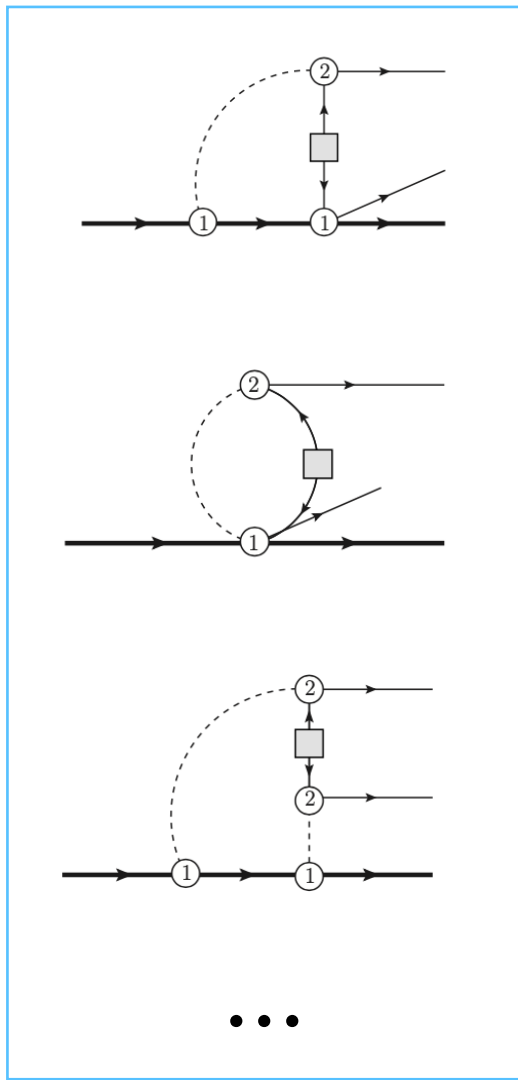

Hadronic neutrinoless double beta decay

- **Hyperon $0\nu 2\beta$ in BChPT**

[Z.-Y. Zhao, Z.-R. Liang, F.-K. Guo, L.-P. He and **DLY**, arXiv:2602.08453 [hep-ph]]

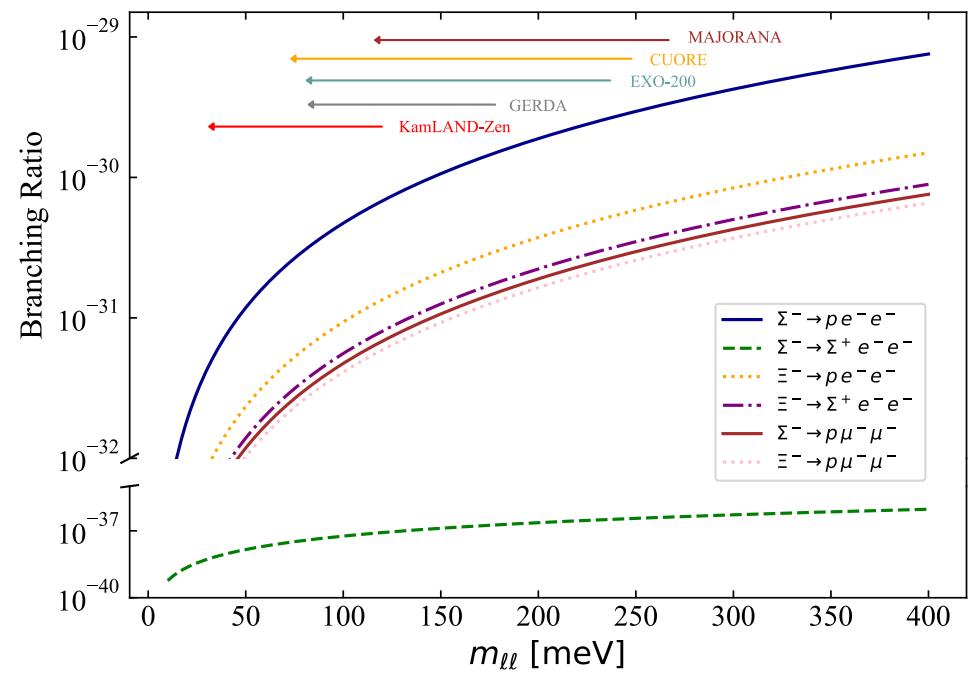
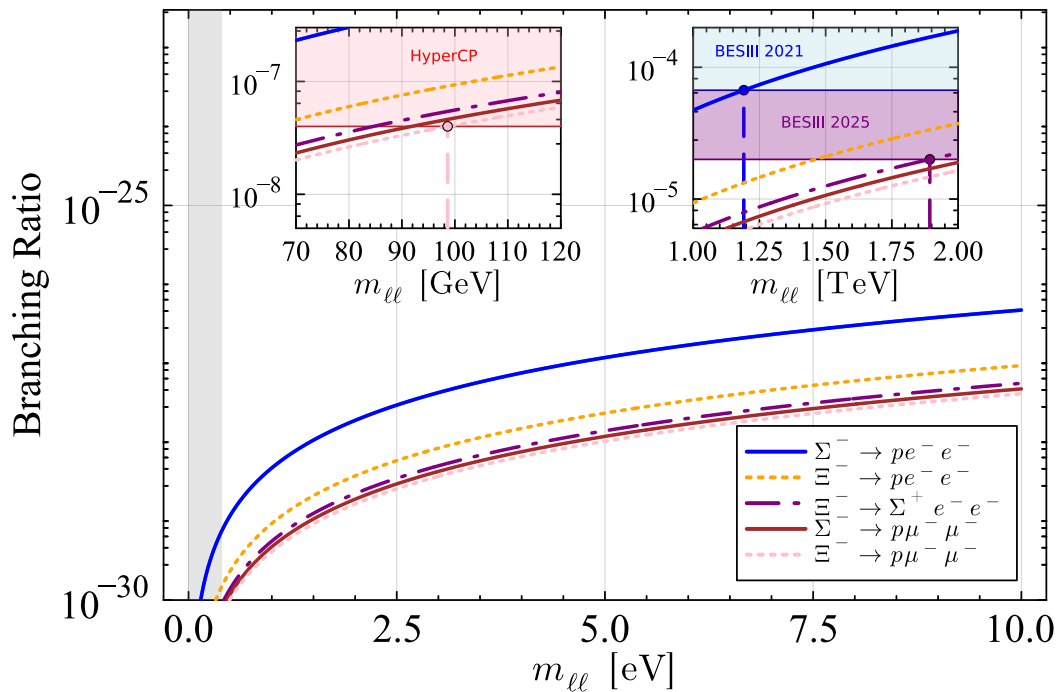

- ▶ Complementary to nuclear $0\nu 2\beta$
- ▶ Future hyperon factory
- ➔ See talk by 赵子赢 on Monday

Process	$\frac{\Gamma_{0\nu}}{m_{\ell\ell}^2}$ [sec ⁻¹ /MeV ²]	$\mathcal{B}(B_1 \rightarrow B_2 \ell^- \ell^-)$	
		This work	Experiments
$\Sigma^- \rightarrow p e^- e^-$	3.194×10^{-7}	4.7×10^{-31}	$< 6.7 \times 10^{-5}$ [26]
$\Sigma^- \rightarrow \Sigma^+ e^- e^-$	3.925×10^{-14}	5.8×10^{-38}	-
$\Sigma^- \rightarrow p \mu^- \mu^-$	3.202×10^{-8}	4.7×10^{-28}	-
$\Xi^- \rightarrow \Sigma^+ e^- e^-$	3.404×10^{-8}	5.6×10^{-32}	$< 2.0 \times 10^{-5}$ [27]
$\Xi^- \rightarrow p e^- e^-$	5.706×10^{-8}	9.4×10^{-32}	-
$\Xi^- \rightarrow p \mu^- \mu^-$	2.509×10^{-8}	4.1×10^{-28}	$< 4.0 \times 10^{-8}$ [25]

Hadronic neutrinoless double beta decay

- **Delta $0\nu 2\beta$ in BChPT**

[He, Zhang, Zhang, Guo, Meissner, **DLY**, in preparation]

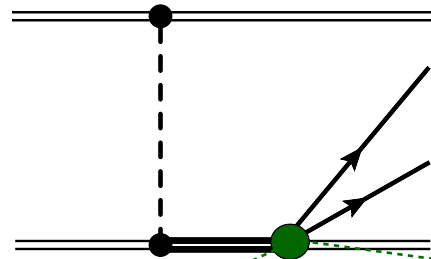

- Towards a deltafull description of $nn \rightarrow ppee$
- Pion mass dependence

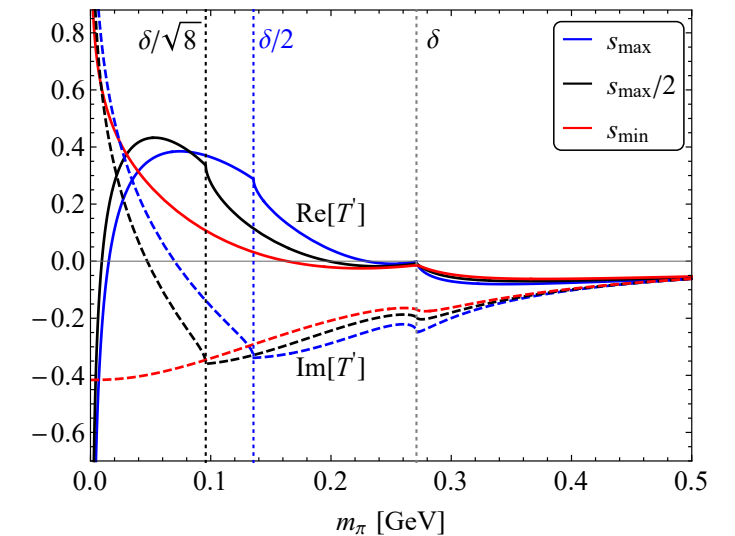
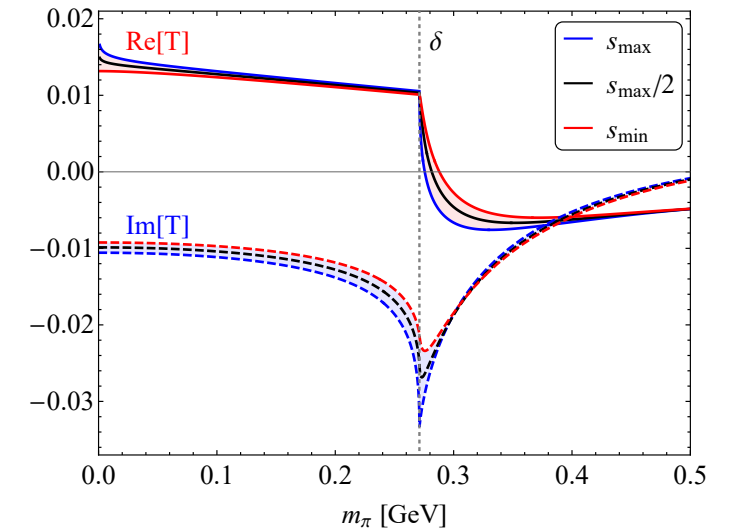
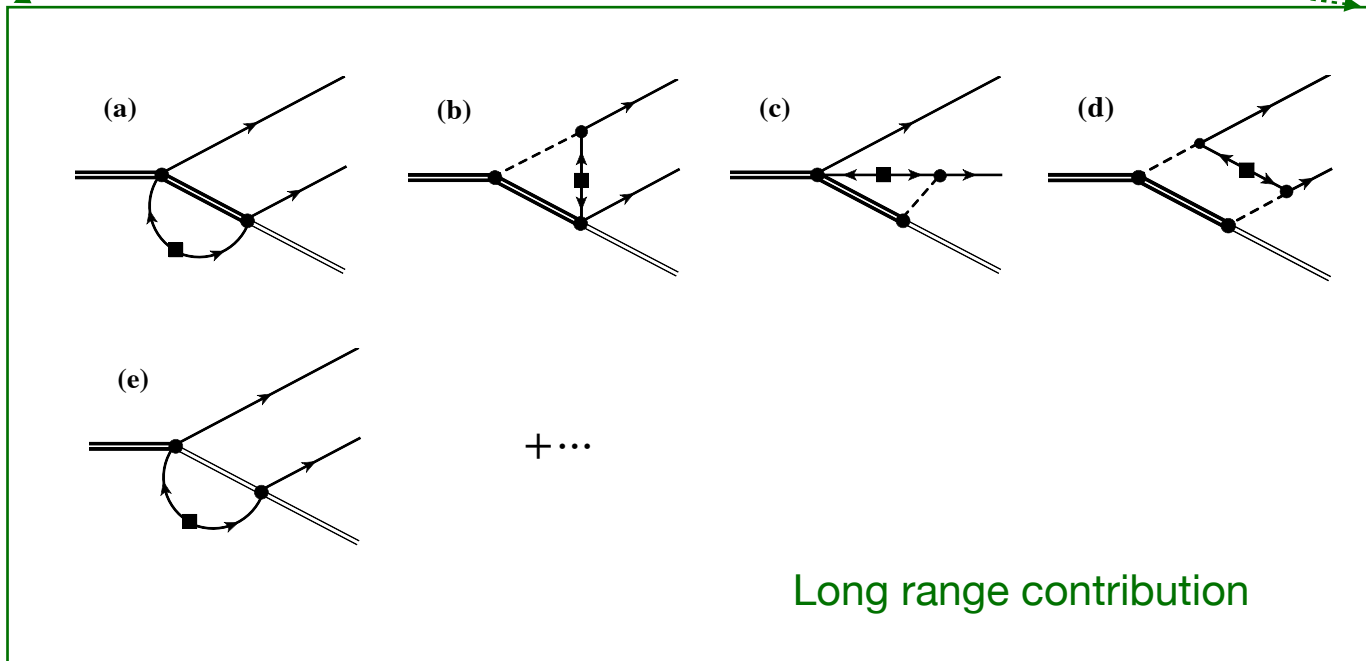

IV. Generalisation to heavy matter fields

Generalisation to heavy matter fields

- Heavy matter fields: D/B mesons, Charmed baryons, ...



Physics Reports
Volume 1019, 28 May 2023, Pages 1-149



Chiral perturbation theory for heavy hadrons and chiral effective field theory for heavy hadronic molecules

Lu Meng ^{a 1}, Bo Wang ^{b c d 1}, Guang-Juan Wang ^{e f 1}, Shi-Lin Zhu ^g

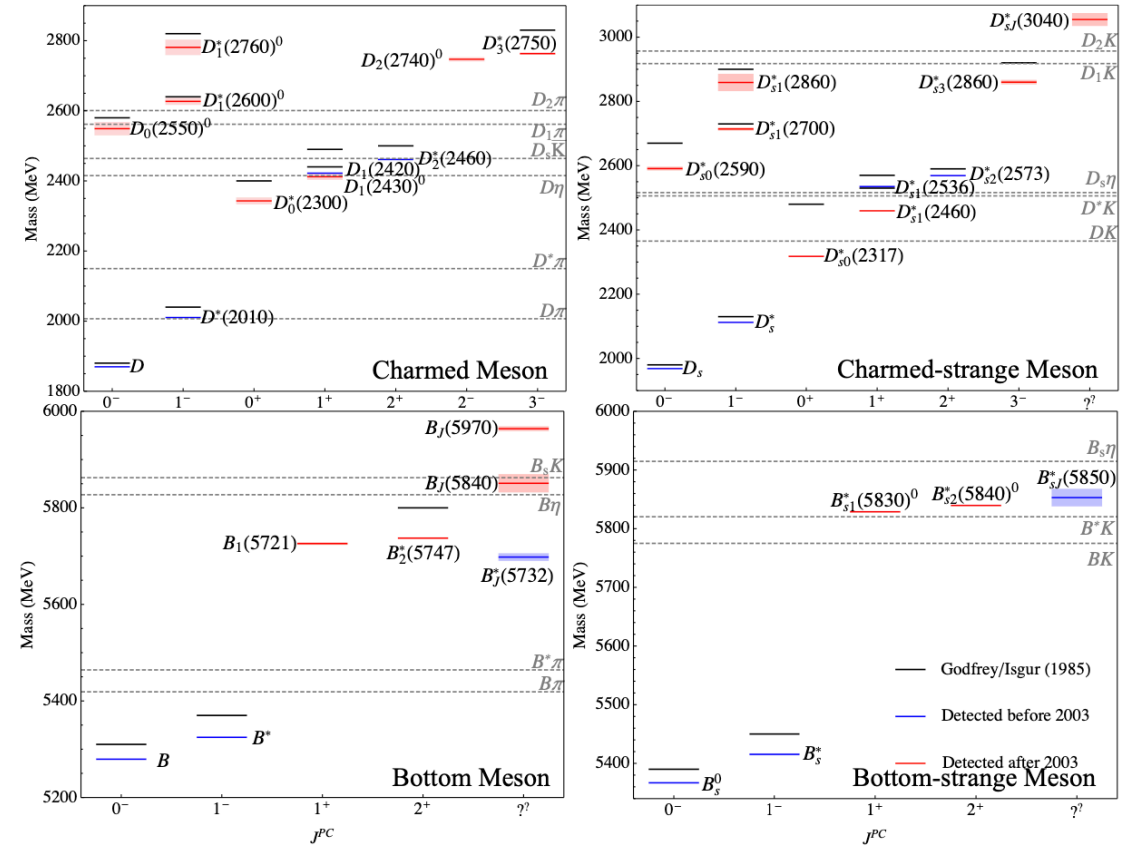
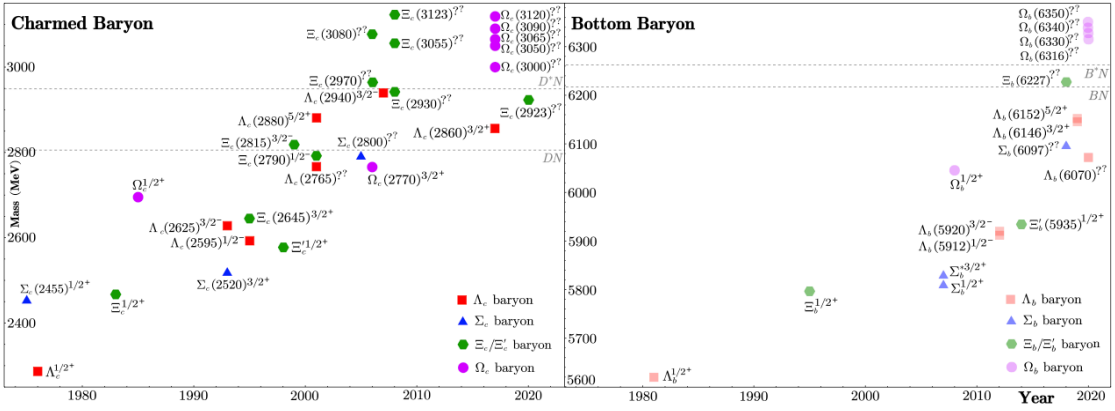

Generalisation to heavy matter fields

- The doubly charmed baryons

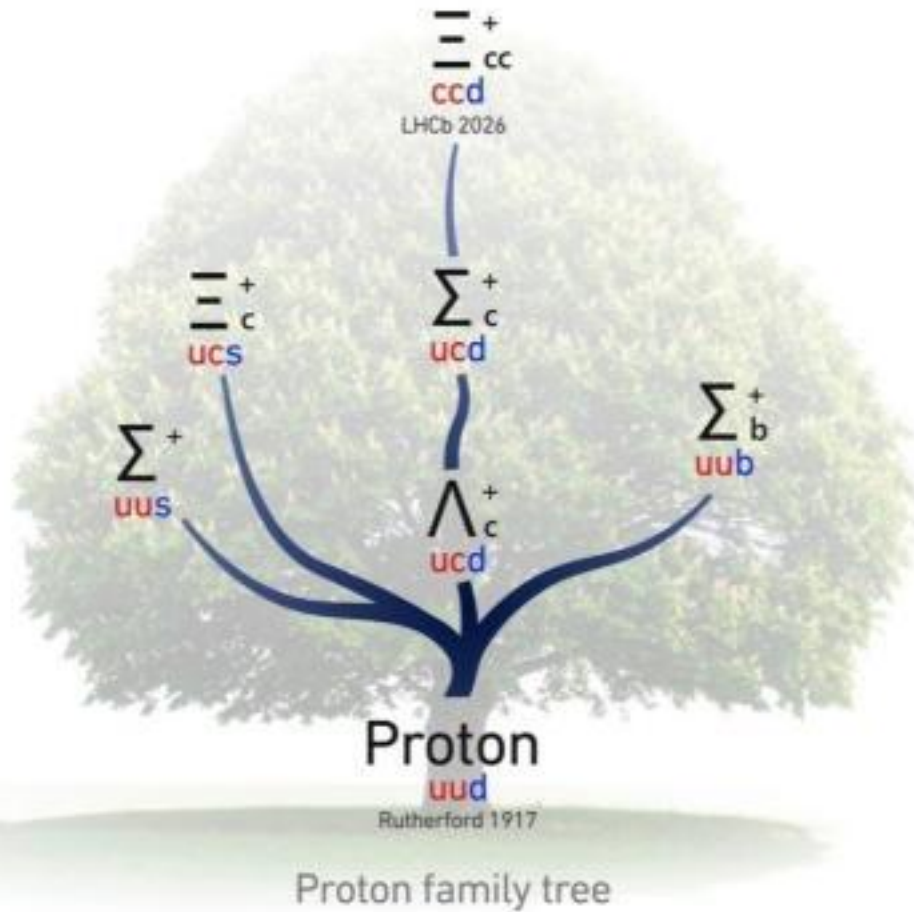

- ▶ Very recent observation of Ξ_{cc}^+ by LHCb
- ▶ Mass: $3619.97 \pm 0.83(\text{stat}) \pm 0.26(\text{syst})_{-1.30}^{+1.90}(\text{life time})$

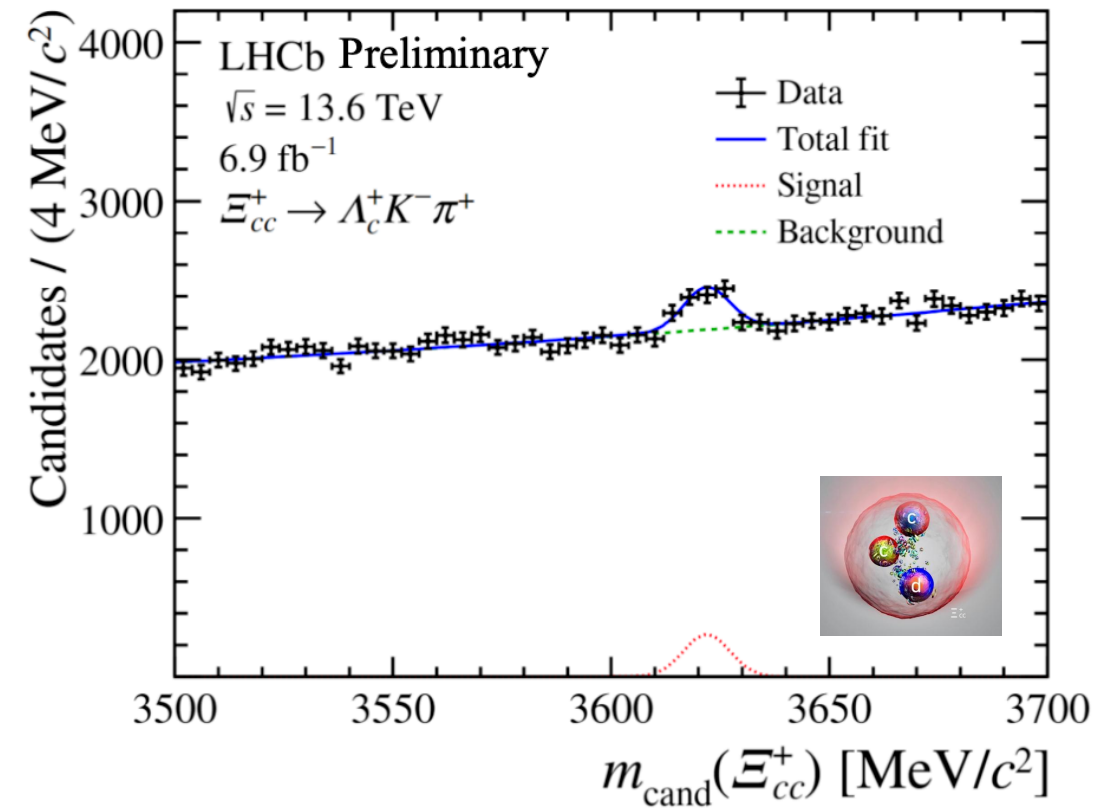

Towards a new paradigm for negative-parity doubly charmed baryons?

➔ Interactions between Goldstone Bosons and DCB

DCB in ChPT

- Interactions between Goldstone Bosons and DCB

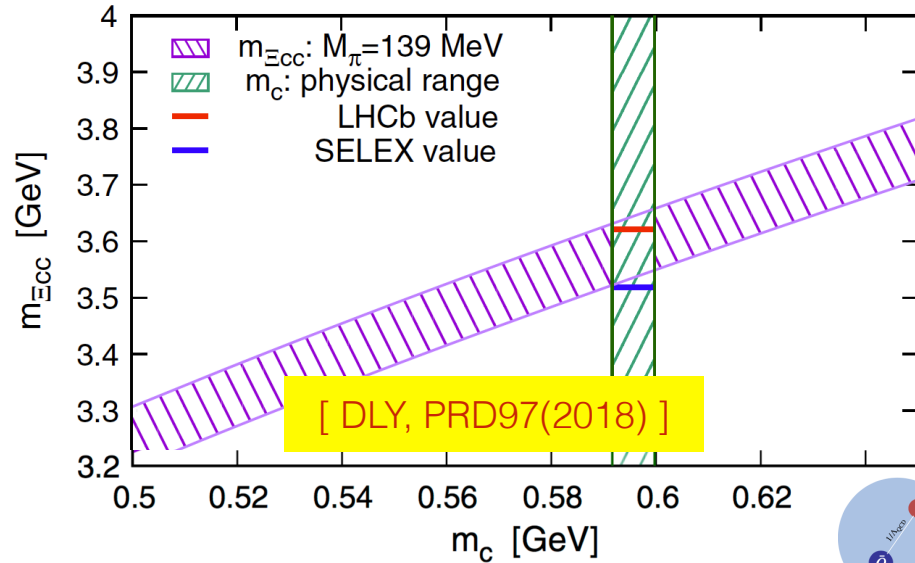

$$\mathcal{L}_{M\psi} = \bar{\psi} \left\{ (i\not{D} - m) + \frac{g_A}{2} \not{\psi} \gamma_5 \right\} + \sum_{i=1}^8 b_i \mathcal{O}_i^{(2)} + \sum_{j=1}^{32} c_j \mathcal{O}_j^{(3)} + \sum_{k=1}^{218} d_k \mathcal{O}_k^{(4)} + \dots \} \psi$$

	Relativistic	Non-relativistic	
$O(p^2)$	1	$\langle \chi_+ \rangle$	$\langle \chi_+ \rangle$
	2	$\tilde{\chi}_+$	$\tilde{\chi}_+$
	3	u^2	u^2
	4	$\langle u^2 \rangle$	$\langle u^2 \rangle$
	5	$\{u^\mu, u^\nu\} D_{\mu\nu} + h.c.$	$-8m^2 (v \cdot u)^2$
	6	$\langle u^\mu u^\nu \rangle D_{\mu\nu} + h.c.$	$-4m^2 \langle (v \cdot u)^2 \rangle$

[P.-C. Qiu & DLY, PRD103(2021)]

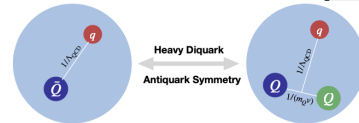

Heavy Diquark-Antiquark Symmetry

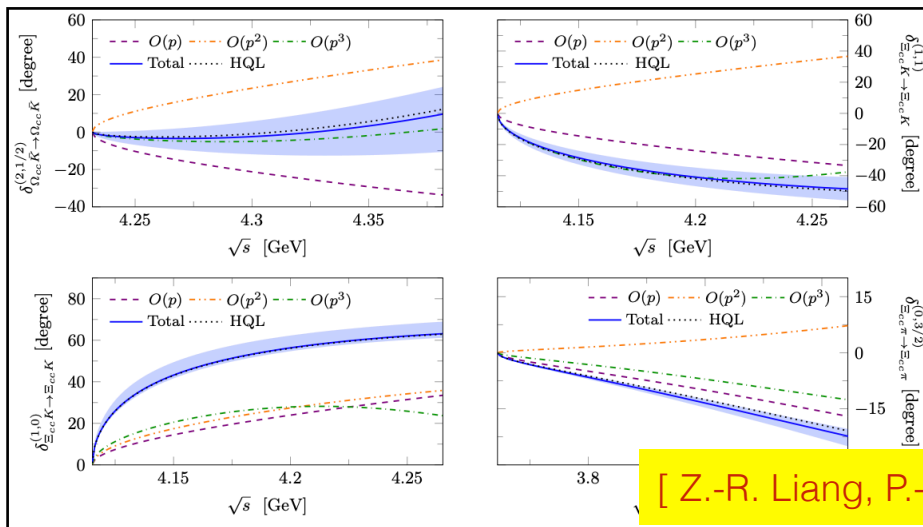

(S, I)	Processes	$O(p^1)$	$O(p^2)$	$O(p^3)$		Total-EOMS	HB
				Tree	Loop		
$(-2, \frac{1}{2})$	$\Omega_{cc}\bar{K} \rightarrow \Omega_{cc}\bar{K}$	-0.27	0.29	-0.11	-0.001	$-0.09^{+0.12}_{-0.13}$	-0.20(1)
(1, 1)	$\Xi_{cc}K \rightarrow \Xi_{cc}K$	-0.27	0.27	-0.13	-0.47	-0.60 ± 0.13	-0.25(1)
(1, 0)	$\Xi_{cc}K \rightarrow \Xi_{cc}K$	0.27	0.34	0.13	0.30	1.03 ± 0.19	0.92(2)
$(0, \frac{3}{2})$	$\Xi_{cc}\pi \rightarrow \Xi_{cc}\pi$	-0.12	0.04	-0.01	-0.06	-0.16 ± 0.02	-0.10(2)
$(-1, 0)$	$\Xi_{cc}\bar{K} \rightarrow \Xi_{cc}\bar{K}$	0.54	0.24	0.25	0.16	$1.19^{+0.22}_{-0.21}$	2.15(11)
	$\Omega_{cc}\eta \rightarrow \Omega_{cc}\eta$	-0.001	0.37	0.0	$0.05 + 0.55i$	$0.42^{+0.18}_{-0.19} + 0.55i$	$0.57(3) + 0.21i$
$(-1, 1)$	$\Omega_{cc}\pi \rightarrow \Omega_{cc}\pi$	0.0	0.04	0.0	-0.04	-0.01 ± 0.02	-0.002(1)
	$\Xi_{cc}\bar{K} \rightarrow \Xi_{cc}\bar{K}$	0.0	0.31	0.0	$-0.04 + 0.10i$	$0.27^{+0.13}_{-0.13} + 0.10i$	$0.26(1) + 0.19i$
$(0, \frac{1}{2})$	$\Xi_{cc}\pi \rightarrow \Xi_{cc}\pi$	0.25	0.04	0.01	0.04	0.34 ± 0.02	0.36(1)
		0.01	0.32	0.0	-0.26	$0.06^{+0.14}_{-0.15}$	$0.34(1) + 0.10i$
		7	0.29	0.11	$-0.01 + 0.55i$	$0.66^{+0.13}_{-0.13} + 0.55i$	$1.18(6) + 0.29i$

DCB in ChPT and lattice QCD

- Chiral extrapolation

[J.-Y. Yi, Z.-R. Liang, L. Liu & **DLY**, JHEP03(2026)]

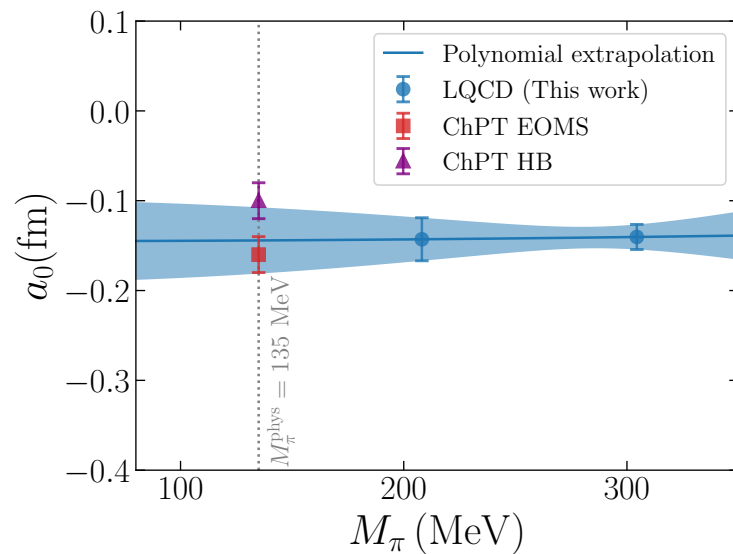
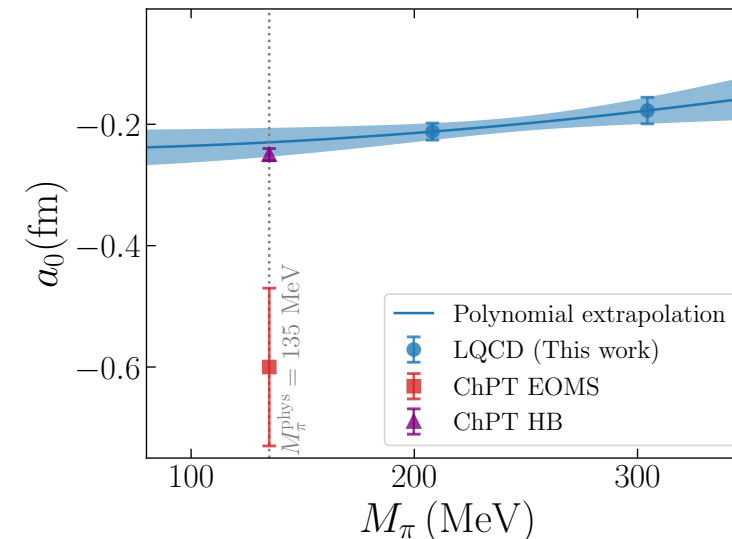
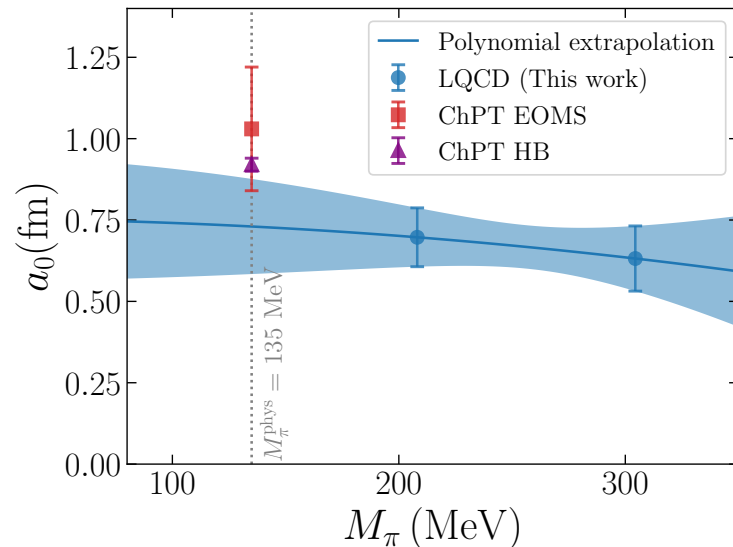
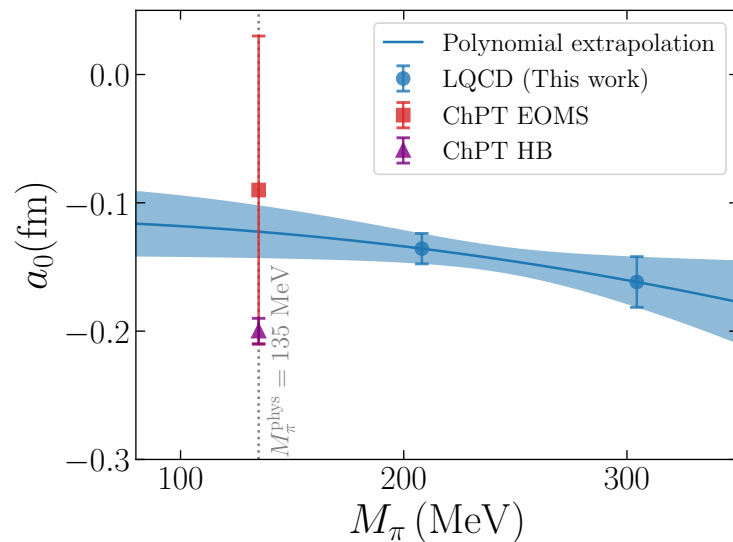

- Single channels: Good agreement using LECs estimated by HADS
- Coupled channels: new DCB states with negative parity

➔ First observation of a negative-parity doubly charmed baryon on lattice

J.-Y. Yi, Z.-R. Liang, L. Liu, **DLY**, in preparation

➔ See talk by J.-Y. Yi on Sunday

(S, I)	Process	EOMS	HB
$(-2, \frac{1}{2})$	$\Omega_{cc}\bar{K} \rightarrow \Omega_{cc}\bar{K}$	$-0.09^{+0.12}_{-0.13}$	-0.20(1)
$(0, \frac{3}{2})$	$\Xi_{cc}\pi \rightarrow \Xi_{cc}\pi$	-0.16 ± 0.02	-0.10(2)
(1, 1)	$\Xi_{cc}K \rightarrow \Xi_{cc}K$	1.03 ± 0.19	0.92(2)
(1, 0)	$\Xi_{cc}K \rightarrow \Xi_{cc}K$	-0.60 ± 0.13	-0.25(1)

Summary

- The nucleon mass and sigma term with two-loop accuracy:

- ▶ Resolving the long-standing tension between lattice QCD and dispersive determinations

$$\sigma_{\pi N} = 55.9(2.5) \text{ MeV}$$

vs

$$\sigma_{\pi N}^{\text{RS}} = 59.1(3.5) \text{ MeV}$$

- Nucleon static properties:

- ▶ Precise determination of D term: $D^N = -3.38^{+0.34}_{-0.35}$

- ▶ Suggesting a modern structural view of the nucleon:

$$\sqrt{\langle r_{\Theta}^2 \rangle} = 0.97^{+0.03}_{-0.03} \text{ fm} > \sqrt{\langle r_{E,p}^2 \rangle} \simeq 0.84 \text{ fm} > \sqrt{\langle r_{\text{Ener}}^2 \rangle} = 0.70^{+0.03}_{-0.04} \text{ fm}$$

proton electric charge

- Others:

- ▶ New physics: neutrinoless double beta decays, CP violations, ...
- ▶ Exotic states,.....

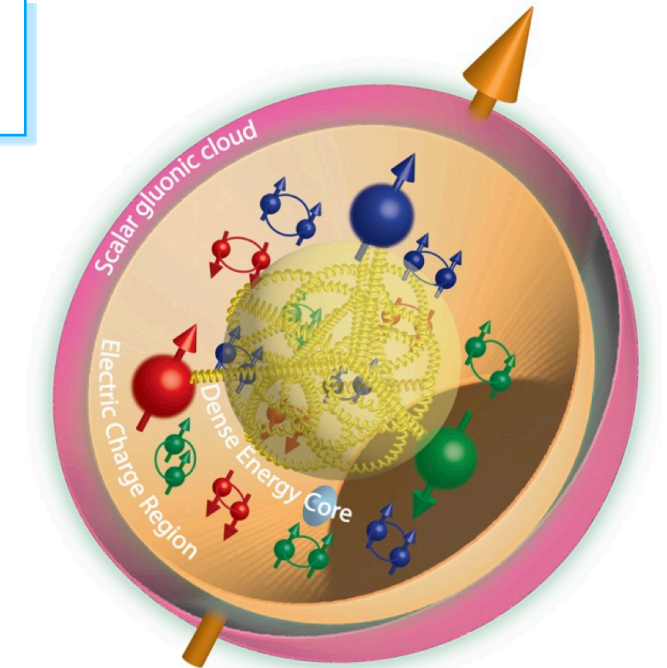

Courtesy of Meziani

Thank you very much!