

# Discovery of Toponium



李海峰

山东大学（青岛）



第五届强子与重味物理理论与实验联合研讨会

2026年3月28日，河北石家庄

# ATLAS (A Toroidal LHC ApparatuS)

Collaboration with ~3000 members

ATLAS

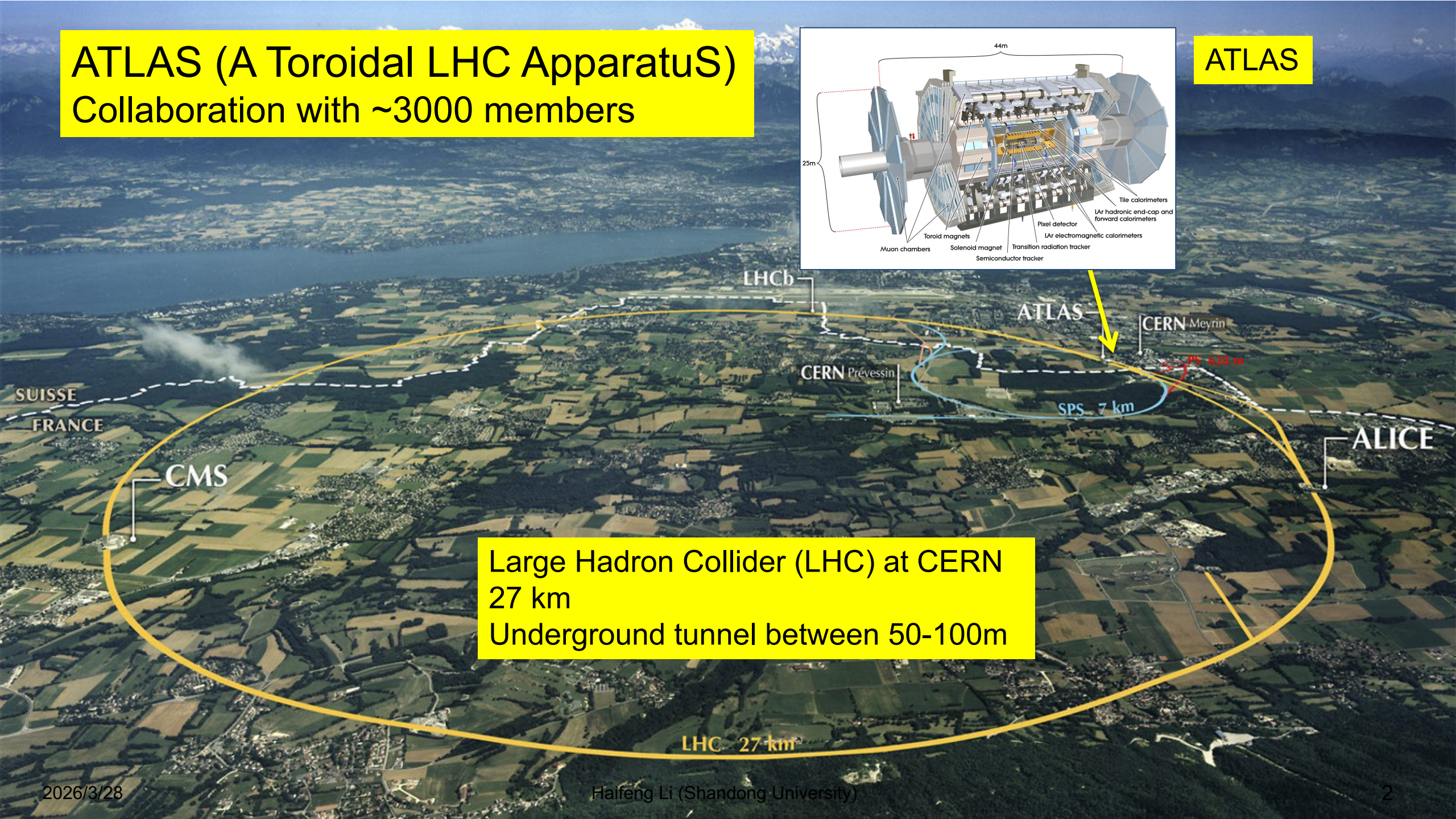
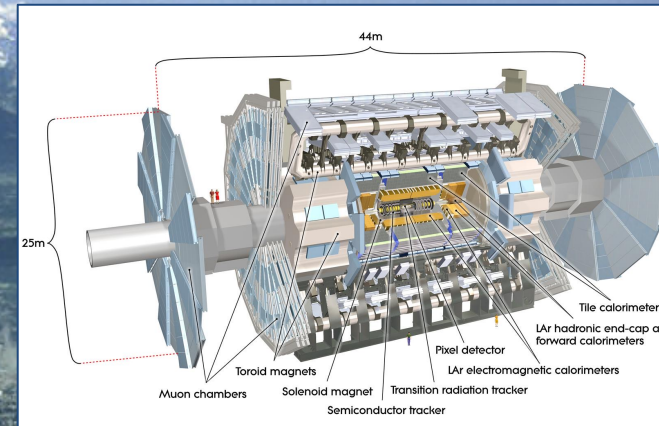

Large Hadron Collider (LHC) at CERN  
27 km  
Underground tunnel between 50-100m

# ATLAS 探测器

7000吨, 长44米, 高25米

强子量能器 ( $|\eta| < 4.9$ )  
Scintillator/Steel

缪子谱仪 ( $|\eta| < 2.7$ )

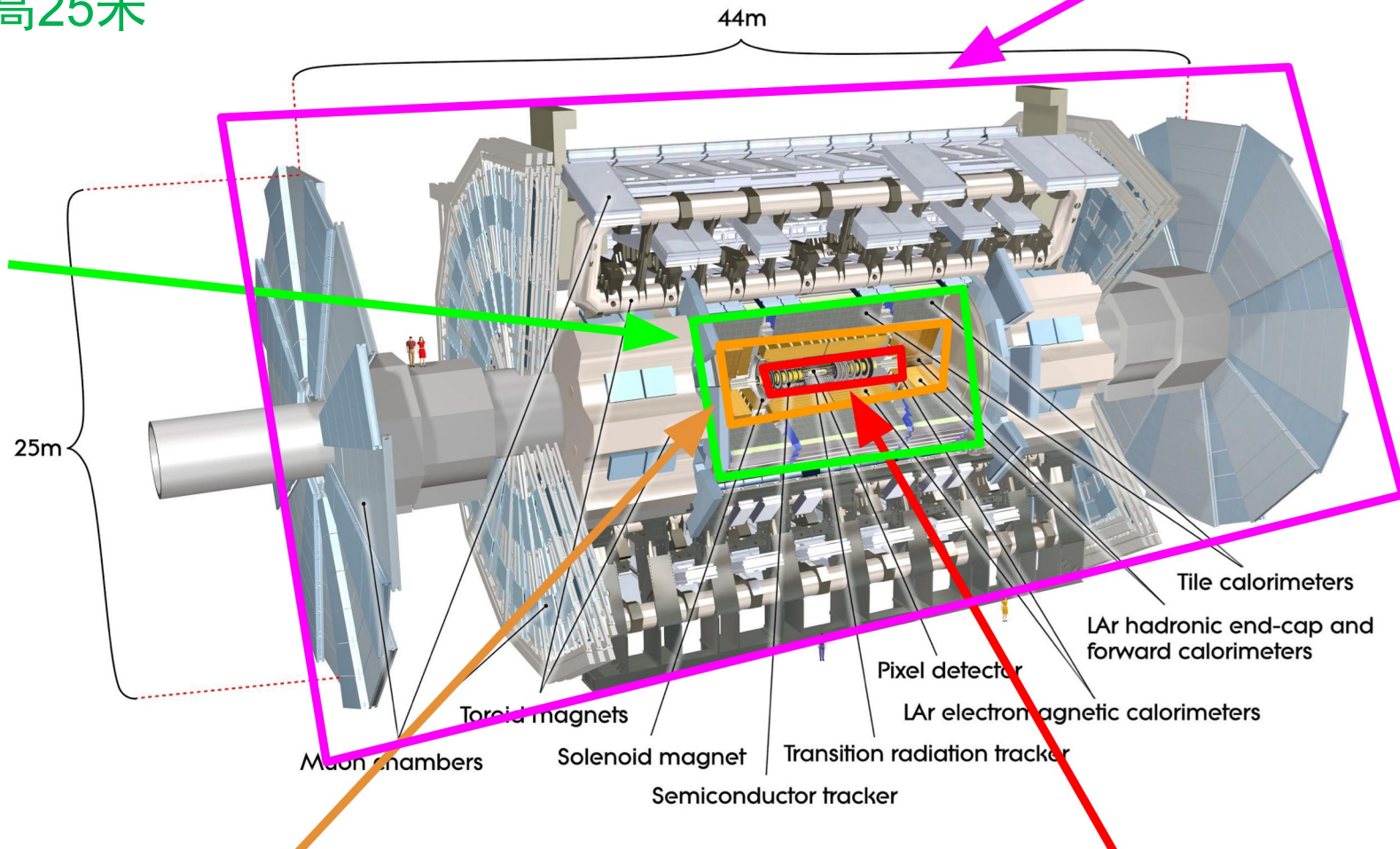

电磁量能器 ( $|\eta| < 3.2$ )  
LAr/Pb

内部径迹探测器 ( $|\eta| < 2.5$ )  
2T Solenoid  
Pixels, SCT and TRT

2881位作者

Status: August 2023



1190 位博士研究生

1304位工程师

- |                |              |
|----------------|--------------|
| Argentina      | Netherlands  |
| Armenia        | Norway       |
| Australia      | Palestine    |
| Austria        | Philippines  |
| Azerbaijan     | Poland       |
| Belarus        | Portugal     |
| Brazil         | Romania      |
| Canada         | Russia       |
| Chile          | Serbia       |
| China          | Slovakia     |
| Colombia       | Slovenia     |
| Czech Republic | South Africa |
| Denmark        | Spain        |
| France         | Sweden       |
| Georgia        | Switzerland  |
| Germany        | Taiwan       |
| Greece         | Türkiye      |
| Israel         | UAE          |
| Italy          | UK           |
| Japan          | USA          |
| Mongolia       | CERN         |
| Morocco        | JINR         |

# ATLAS 合作组

## ATLAS Collaboration

182 institutions (250 institutes) from 42 countries

5940位活跃的成员



# LHC Schedule

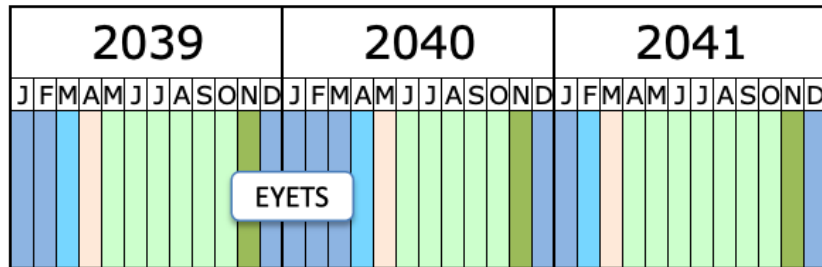
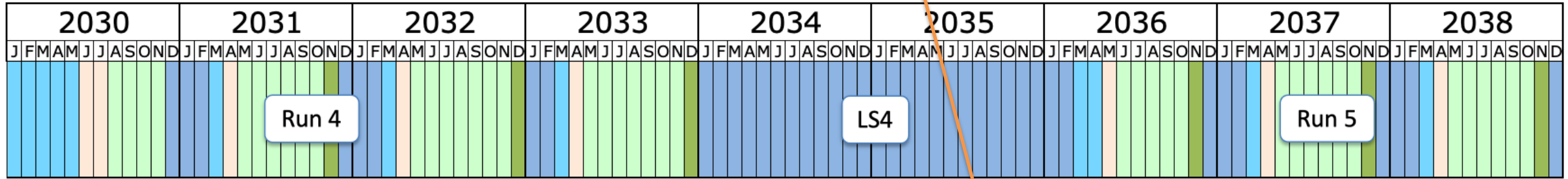
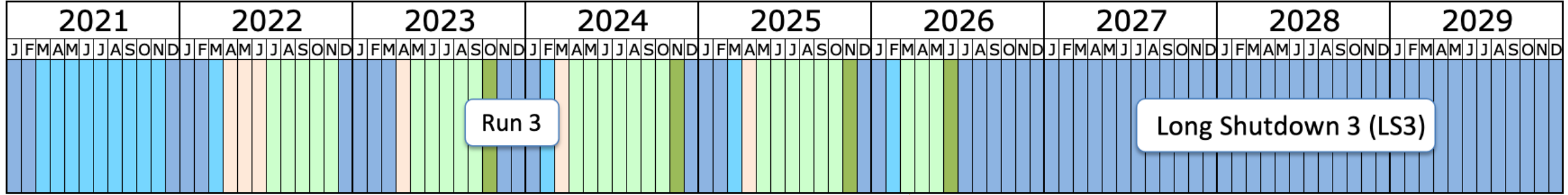

Last update: November 24

- Shutdown/Technical stop
- Protons physics
- Ions
- Commissioning with beam
- Hardware commissioning

目前

Run 2	140 fb <sup>-1</sup>
Run 2 + Run 3	510 fb <sup>-1</sup>

# ATLAS实验从LHC运行以来共发表文章1424篇

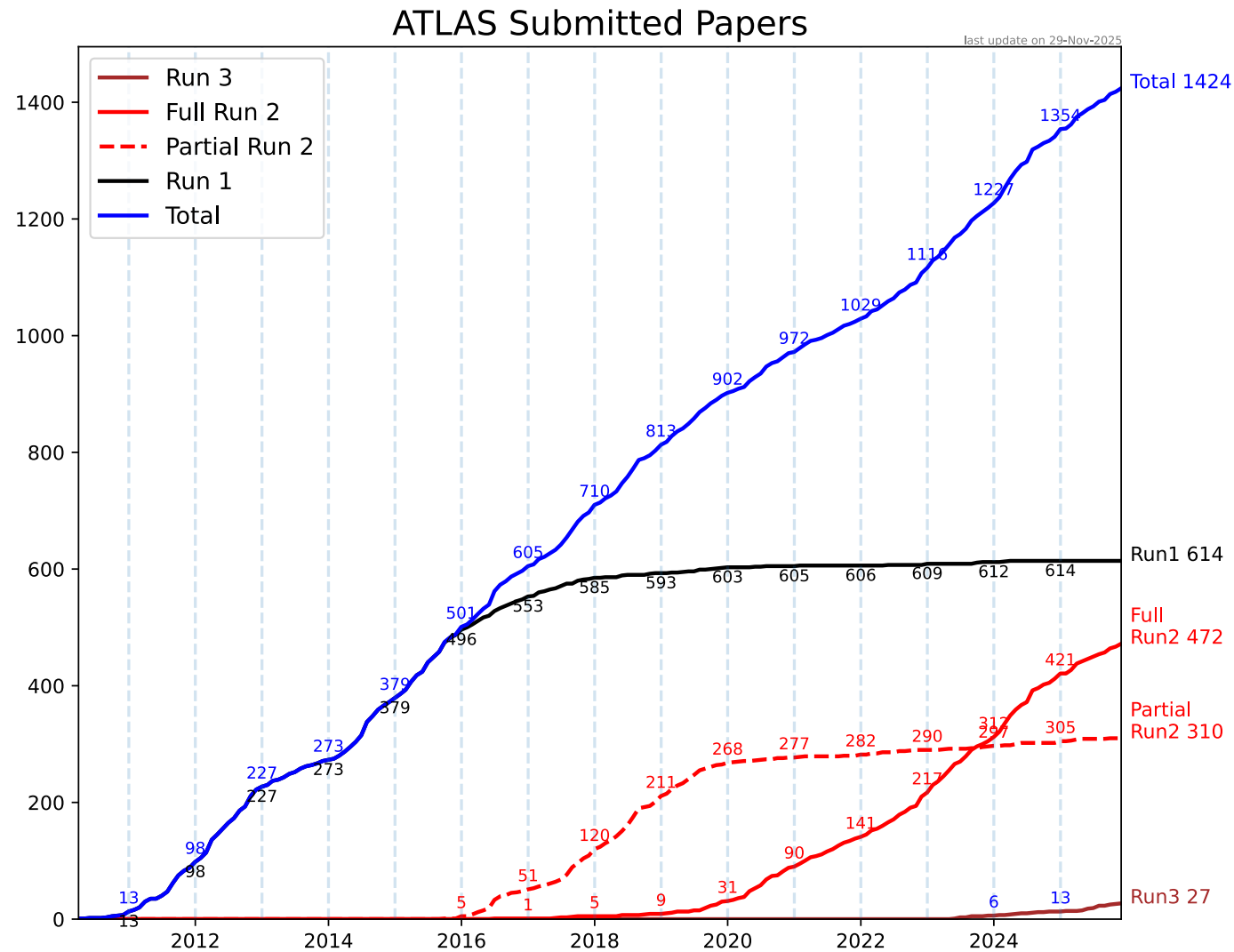

# Introduction

- Top quark is very special. Heaviest quark in the SM. Has largest Yukawa coupling to the Higgs field ( $y_t \sim 1$ )
- **Very short life time  $\rightarrow$  decays before forming any real hadron  $\rightarrow$  access to 'bare' quark**

$$\underbrace{\frac{1}{m_t}}_{\text{production } 10^{-27} \text{ s}} < \underbrace{\frac{1}{\Gamma_t}}_{\text{lifetime } 10^{-25} \text{ s}} < \underbrace{\frac{1}{\Lambda_{\text{QCD}}}}_{\text{hadronization } 10^{-24} \text{ s}} < \underbrace{\frac{m_t}{\Lambda^2}}_{\text{spin-flip } 10^{-21} \text{ s}}$$

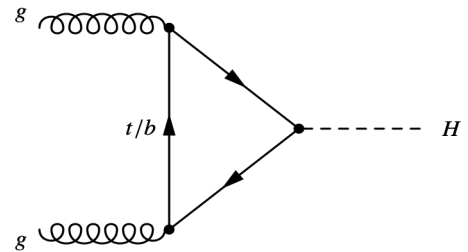

[Nature 607, 52–59 \(2022\)](#)

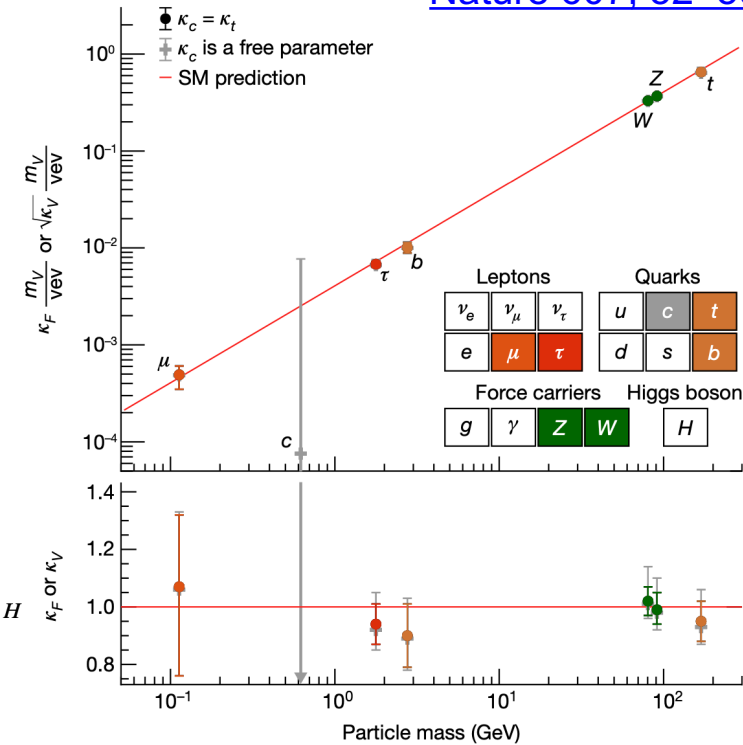

- **Precision measurements of top quark:** important for testing the SM and looking for new physics beyond SM

30th anniversary of the top-quark discovery

# LHC is a top quark factory

- LHC is a  $t\bar{t}$  factory
  - $\sigma_{t\bar{t}} = 834 \text{ pb}$  at LHC Run 2
  - $0.83\text{M } t\bar{t}$  events per  $\text{fb}^{-1}$
  - Due to the short life time, can measurement  $t\bar{t}$  spin correlations
- With those huge amount of  $t\bar{t}$  data, ATLAS has carried out precision measurements in top quark physics
- Thanks to the advanced MC generators and high-order QCD/EW calculations

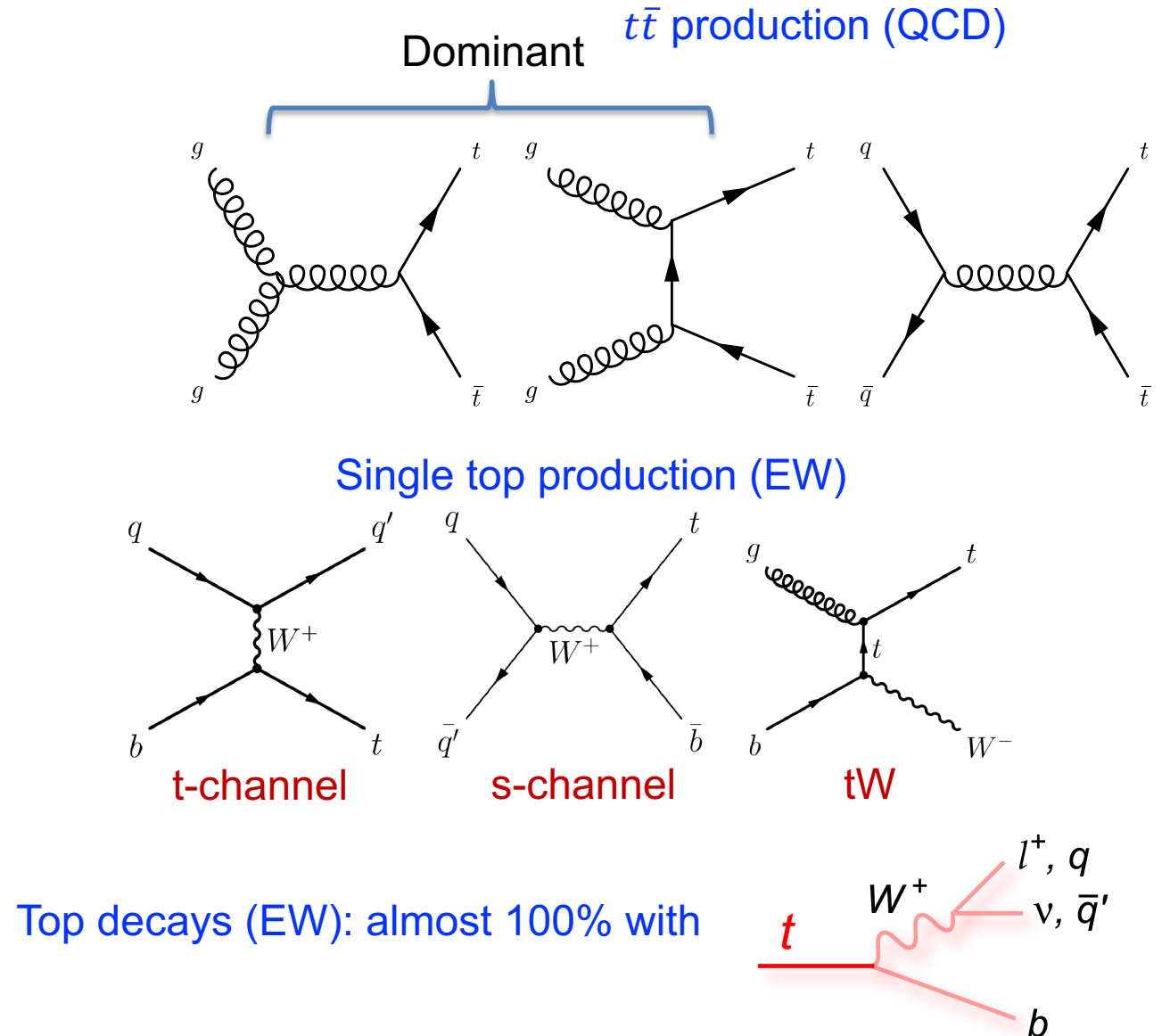

# Top quark and $t\bar{t}$ Threshold Region

QCD predicts a quasi-bound state close to the threshold for low momentum top quarks (the prediction was made even before the top quark discovery)

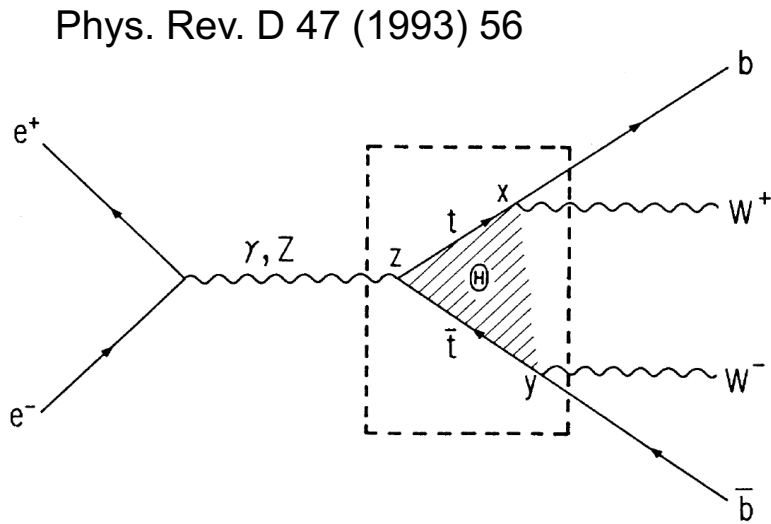

部分理论文章:

V.S. Fadin and V.A. Khoze, JETP Lett. 46 (1987) 525

Y. Sumino *et al.*, Phys. Rev. D 47 (1993) 56

W.-L. Ju *et al.*, JHEP 06 (2020) 158 (浙大杨李林教授团队)

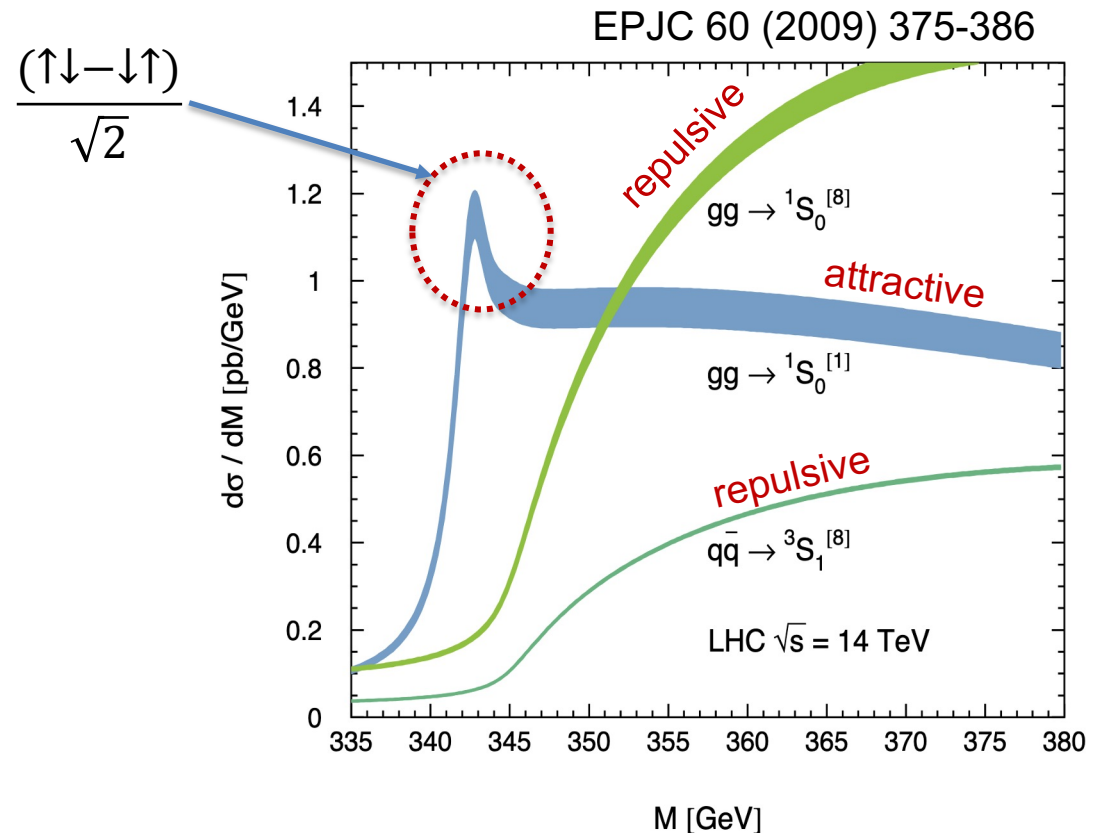

# Top-antitop production near threshold

$1 \text{ GeV}^{-1} = 6.852 \times 10^{-25} \text{ s}$

From B. Fuks

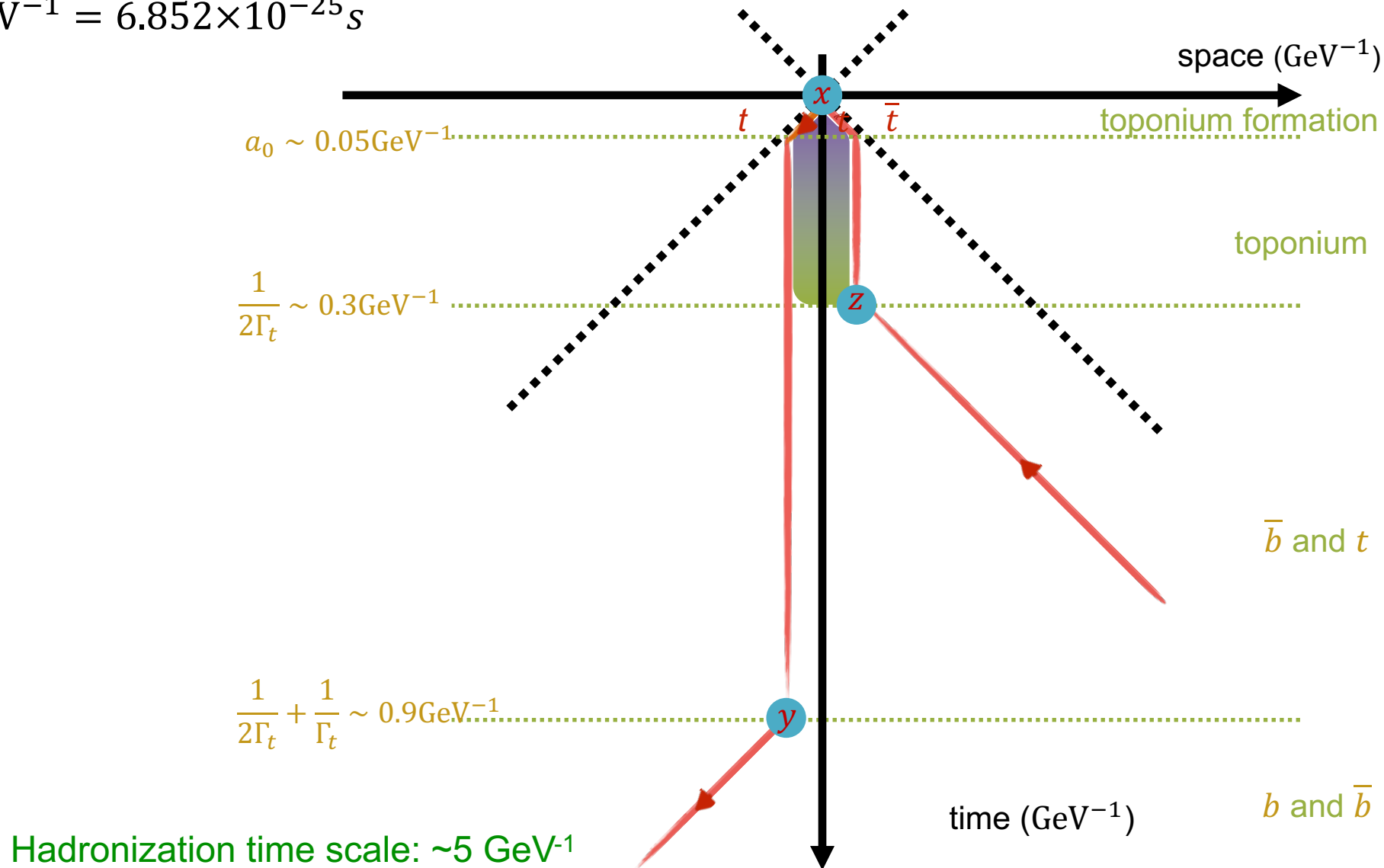

# The toponium Green's function

From B. Fuks

$$K_{abcd}(x, y, z) = \langle 0 | T \{ t_c(y) \bar{t}_d(z) : \bar{t}_a(x) t_b(x) : \} | 0 \rangle$$

$$= \frac{(1 + \gamma^0)_{ca}}{2} \frac{(1 - \gamma^0)_{bd}}{2} \int d^3r \left[ K_1(y; (z^0, \vec{r})) K_2(z^0, \vec{r}, \vec{z}; x^0, \vec{x}, \vec{x}) + K_1(z; (y^0, \vec{r})) K_2(y^0, \vec{y}, \vec{r}; x^0, \vec{x}, \vec{x}) \right]$$

Antitop-decay first
Top-decay first

↑
↑

←
←
→
→

Non-relativistic spin projection operators
1-particle-state and 2-particle-state propagators

## The toponium Green's function

- Solution to the Lippmann-Schwinger equation
  - Fourier transform of the QCD potential
  - S-wave contributions
- To be solved numerically

$$\widetilde{G}(E; p) = \widetilde{G}_0(E; p) + \int \frac{d^3q}{(2\pi)^3} \widetilde{V}_{\text{QCD}}(\vec{p} - \vec{q}) \widetilde{G}(E; q)$$

↑
Free Green's function

# Quasi-bound State from NRQCD

- S-wave, color-singlet state with Green's function of non-relativistic (NR) QCD by [Eur. Phys. J. C 85 \(2025\) 157](#) (B. Fuks, K. Hagiwara, 马凯, 郑亚娟)
- Generate  $gg \rightarrow tt \rightarrow b\ell\nu b\ell\nu$  with MG5\_aMC. Spin correlations included
- Reweight matrix element with QCD Green's functions

$$|\mathcal{M}|^2 \rightarrow |\mathcal{M}|^2 \left| \frac{\tilde{G}(E; p^*)}{\tilde{G}_0(E; p^*)} \right|^2$$

$\tilde{G}$ : Green's function considering QCD potential

$\tilde{G}_0$ : Free Green's function

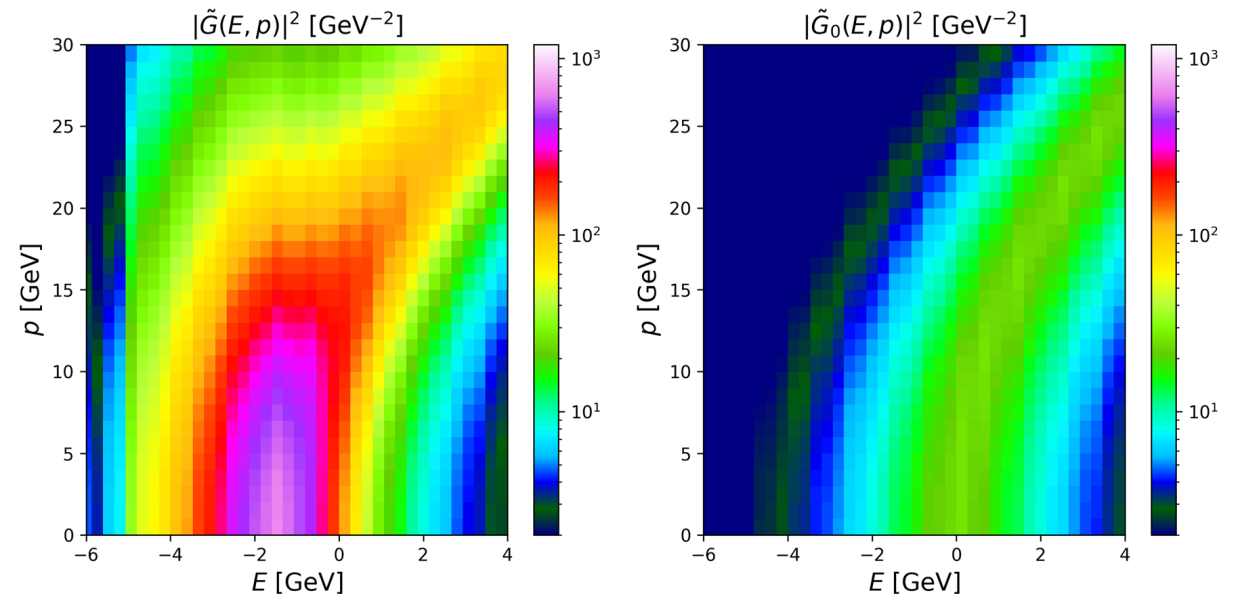

This model includes NRQCD calculations. More complete w.r.t. previous simplified models (using scalar/pseudoscalar as an effective model)

# ATLAS Event Selections

Target for dilepton channel  $tt \rightarrow b\ell\nu b\ell\nu$

SR: Signal Region;

CR: Control Region

140 fb<sup>-1</sup> LHC  
Run 2 pp data

SRs	CR-Z	CR-Fakes
	$= 2\ell$ with $p_T(\ell) \geq 10$ GeV $\geq 1$ trigger-matched lepton with $p_T \geq 25/27/28$ GeV $\geq 2$ jets with $p_T \geq 25$ GeV $\geq 1$ $b$ -tagged jet (70% efficiency WP) $m_{\ell\ell} \geq 15$ GeV for $ee$ and $\mu\mu$ events $m_{t\bar{t}} \leq 500$ GeV	
	$E_T^{\text{miss}} \geq 60$ GeV for OSSF events	—
$\ell^\pm \ell'^\mp$	$e^\pm e^\mp / \mu^\pm \mu^\mp$	$\ell^\pm \ell'^\pm$
$ m_{\ell\ell} - m_Z  \geq 10$ GeV	$ m_{\ell\ell} - m_Z  \leq 10$ GeV	$ m_{\ell\ell} - m_Z  \geq 10$ GeV

OSSF: opposite-sign, same-flavor

CRs are for correcting Z+jets and Fakes normalization in fit

# Background Modelling

Extremely challenging measurement: need precise modelling of the  $t\bar{t}$  threshold region

- $t\bar{t}$ : main background. Powheg v2 hvq + Pythia8, using narrow-width approximation (NWA), with approximate spin correlation
  - 2D reweighting in  $(\cos\theta^*, M(t\bar{t}))$  to NNLO QCD (from MATRIX) and NLO EW (HATHOR)
  - $\theta^*$ : angle between the momentum of the top quark in the  $t\bar{t}$  center-of-mass frame and the momentum of the  $t\bar{t}$  system in the lab. frame
- $t\bar{t}$ : alternative MC sample (for syst.), Powheg v2 bb4l + Pythia8
  - Simulate  $pp \rightarrow b\ell\nu b\ell\nu$  including off-shell, non-resonant contributions, and exact spin correlations at NLO

Advanced MC generators and state-of-art high-order QCD/EW calculations play crucial roles in this search

# Event Categorization

SR events are categorized into 9 regions based on two observables:  $c_{hel}$  and  $c_{han}$

$$c_{hel} = \vec{\ell}_+ \cdot \vec{\ell}_-,$$

where the  $\vec{\ell}_\pm$  are the lepton directions in  $t\bar{t}$  center-of-mass frame, and then in turn boosted into  $t$  and  $\bar{t}$  frames. This distribution has a maximum slope for a spin-singlet state

$c_{han}$ : flip the  $\vec{\ell}$  in  $t$  direction. This distribution has a maximum slope for a spin-triplet state

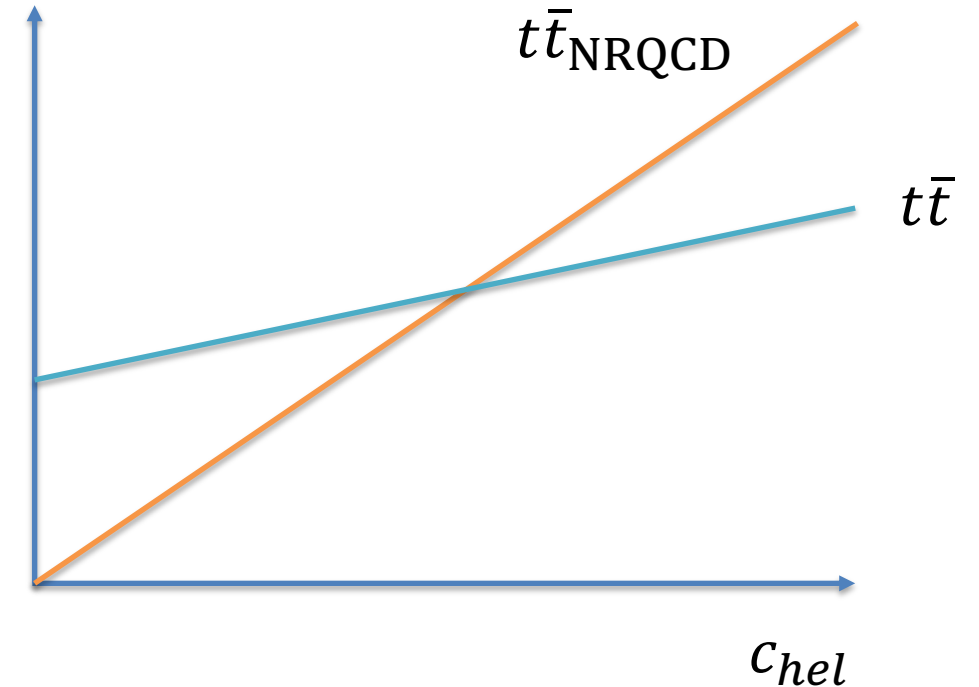

$c_{hel}$  is useful to separate pseudoscalar from other contributions

# Event Categorization and Fitting

	$-1 < c_{hel} < -\frac{1}{3}$	$-\frac{1}{3} < c_{hel} < \frac{1}{3}$	$\frac{1}{3} < c_{hel} < 1$
$-1 < c_{han} < -\frac{1}{3}$	SR1	SR2	SR3
$-\frac{1}{3} < c_{han} < \frac{1}{3}$	SR4	SR5	SR6
$\frac{1}{3} < c_{han} < 1$	SR7	SR8	SR9

CR-Fakes $ee$	CR-Fakes $e\mu$	CR-Fakes $\mu\mu$
---------------	-----------------	-------------------

CR-Z

Simultaneous fitting to  $m_{t\bar{t}}$  with 13 categories with profile likelihood method

# Background Estimations

- $t\bar{t}$ : with a free-floating scale factor (SF);  $tW$ : estimation from MC
- $Z$ +jets: get some contributions from  $Z \rightarrow \tau\tau$ . Use the CR-Z to normalize the  $Z$ +b process

- fake / non-prompt leptons: Fakes represent 1.5% of SR yields. Data-driven estimation with 3 CR-Fakes

GFRW:  
Green's Function Reweighted

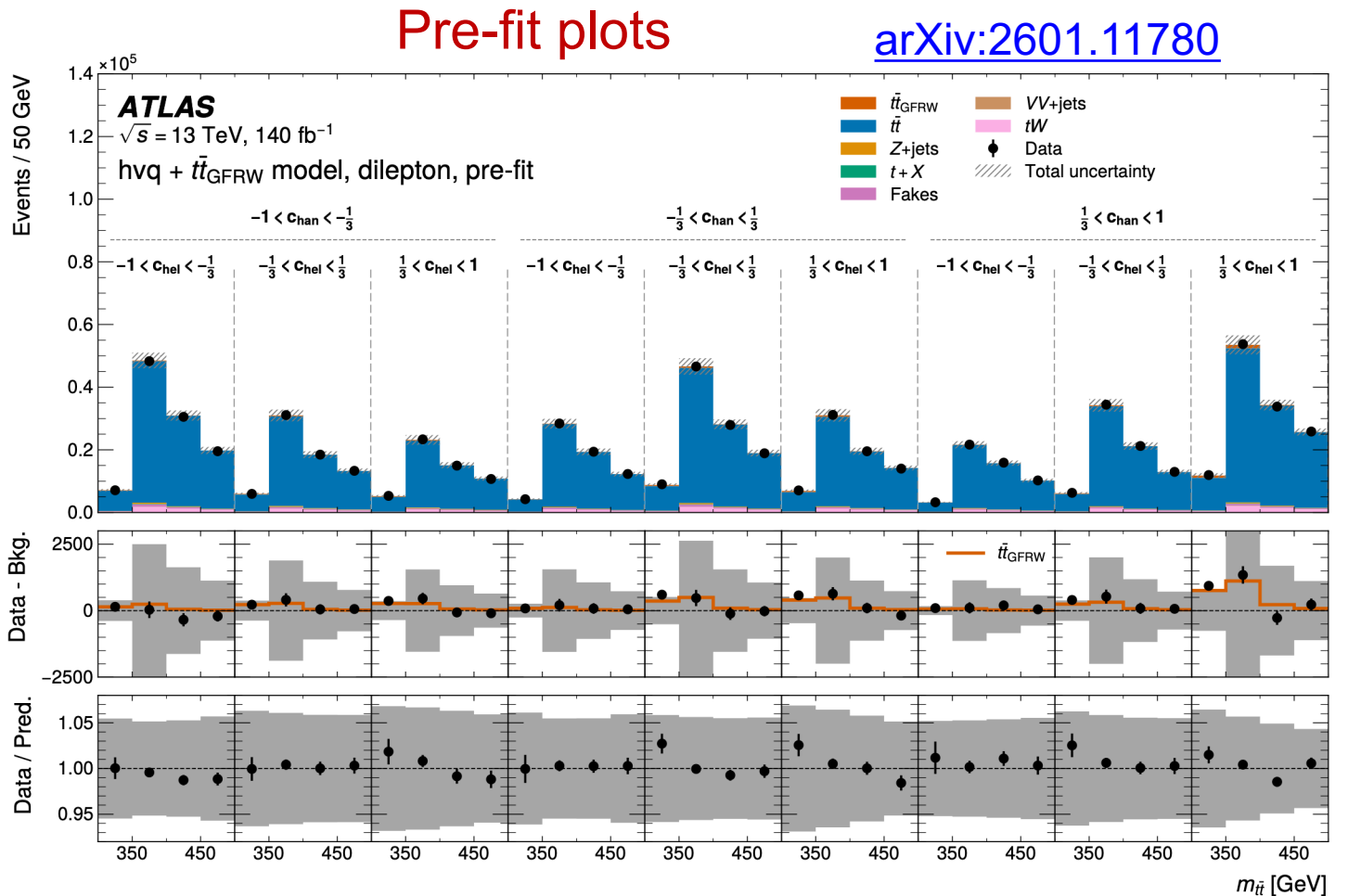

# Results: baseline $t\bar{t}$ + quasi-bound state (NRQCD)

[arXiv:2601.11780](https://arxiv.org/abs/2601.11780)

Observed (expected)  
significance:  $8\sigma$  ( $6\sigma$ )

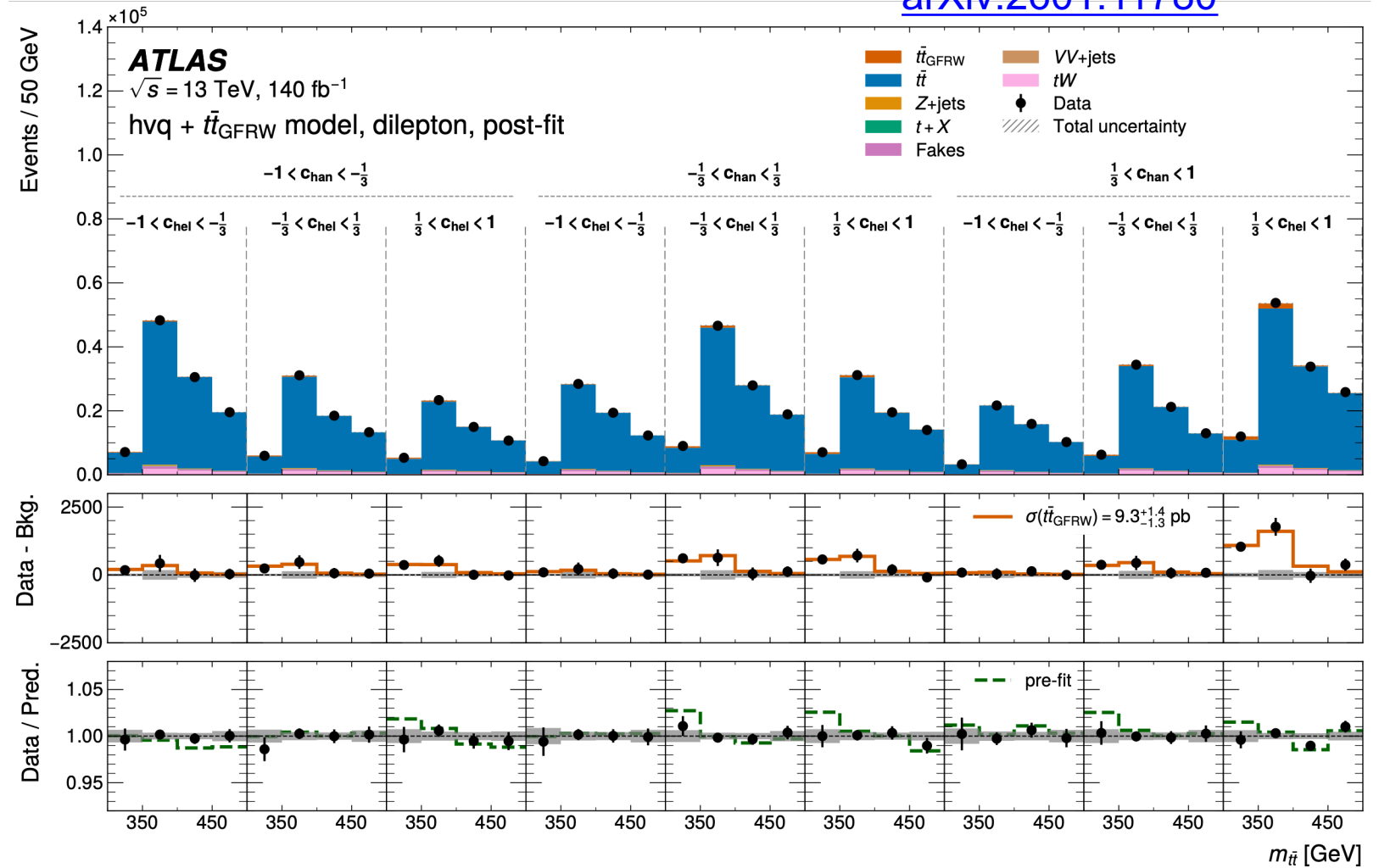

$$\sigma(t\bar{t}_{\text{GFRW}}) = 9.3^{+1.4}_{-1.3} \text{ pb} = 9.3^{+1.1}_{-1.0} (\text{stat.}) \pm 0.8 (\text{syst.}) \text{ pb}$$

Run: 338183  
Event: 3295623881  
2017-10-14 09:08:09 CEST

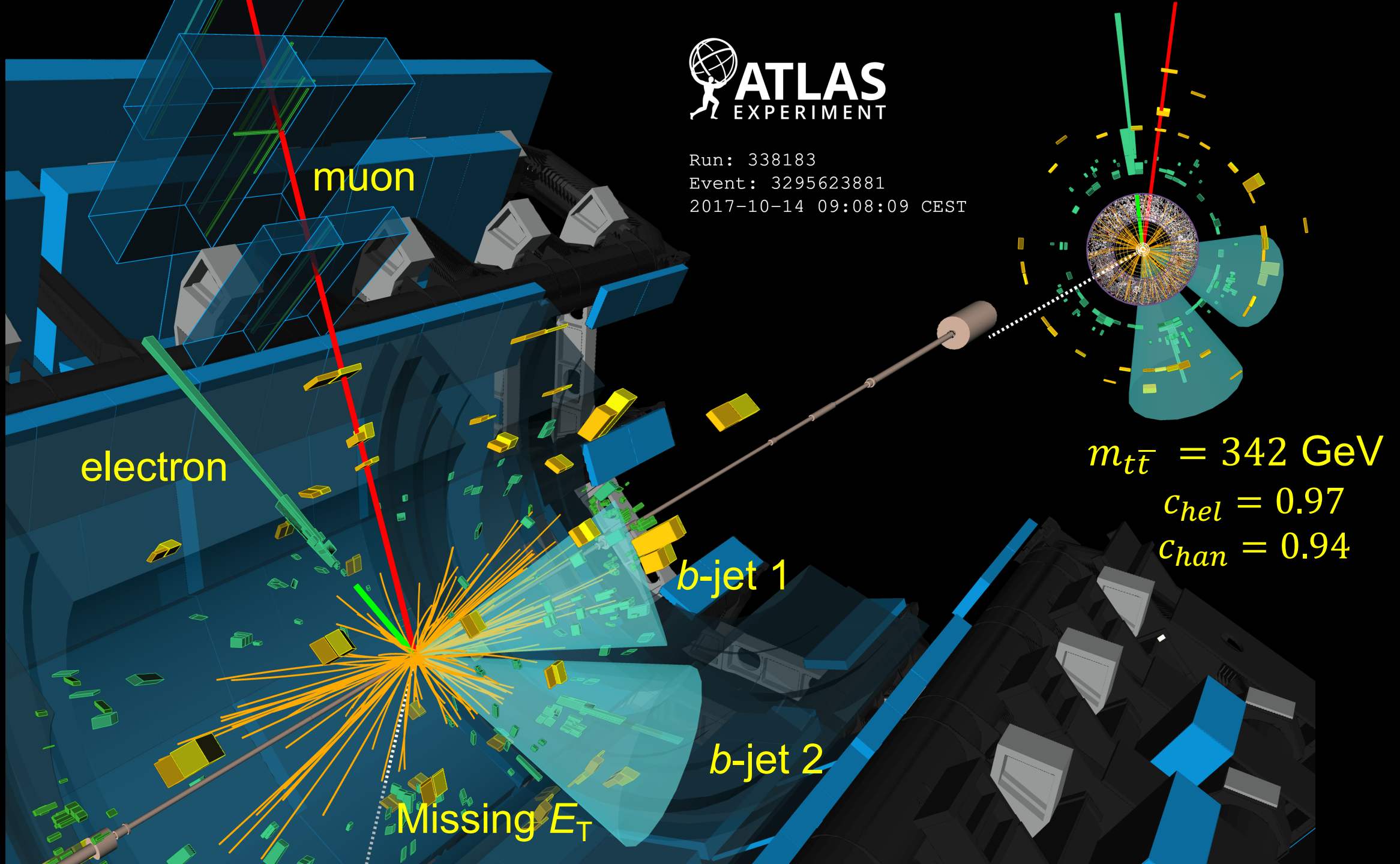

# CMS Results

# CMS Results: 2L

- [arXiv:2503.22382](https://arxiv.org/abs/2503.22382), [Rep. Prog. Phys. 88 \(2025\) 087801](#)
- Use very similar analysis method compared with ATLAS
- Use toy model for signal

显著度大于 $5\sigma$

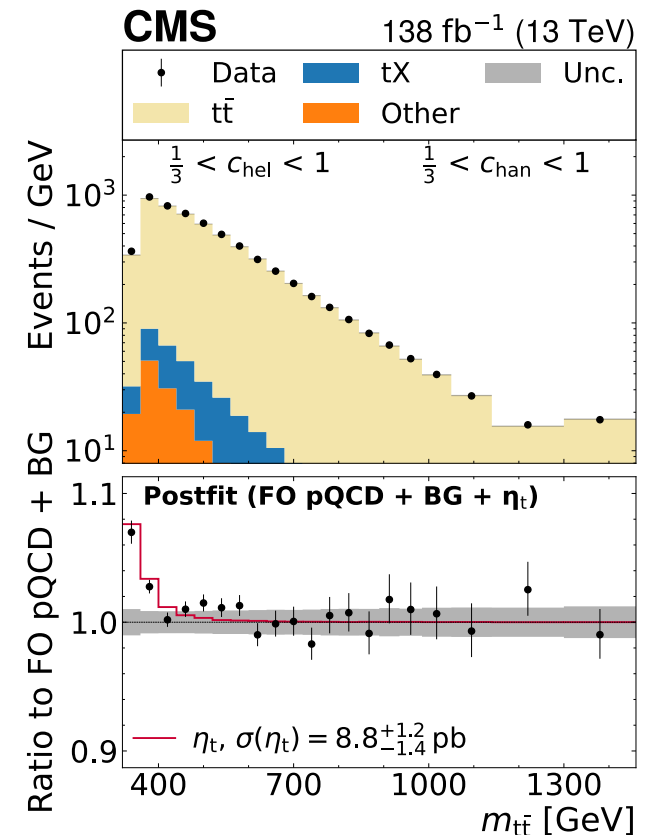
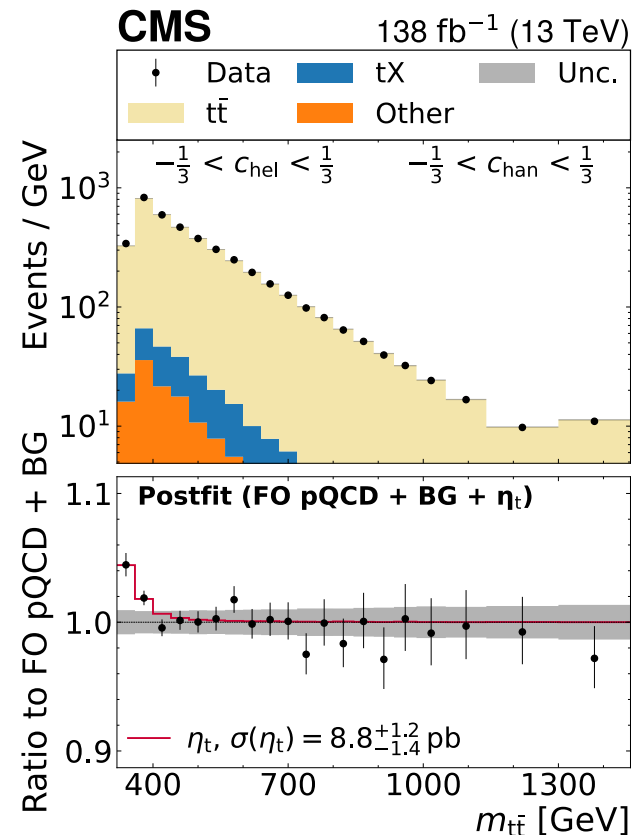
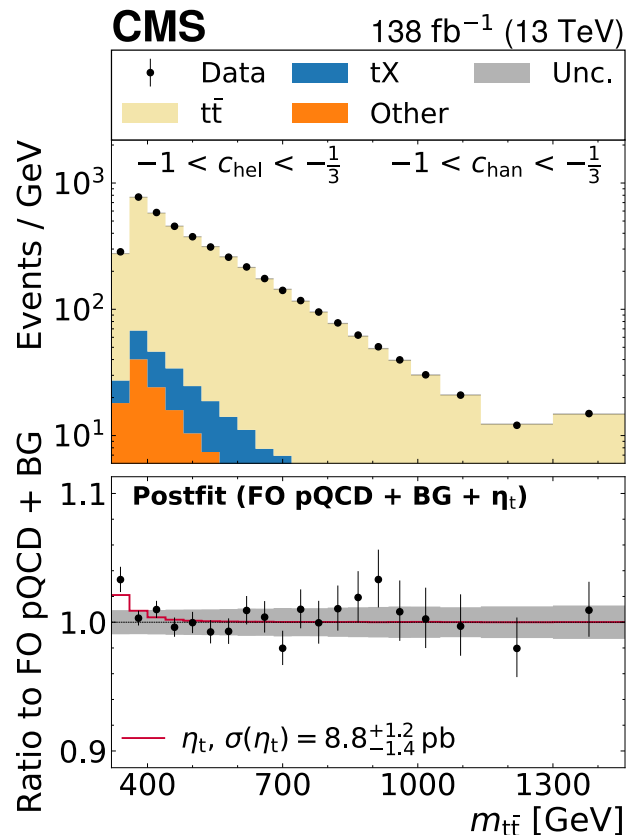

# Comparison of different models

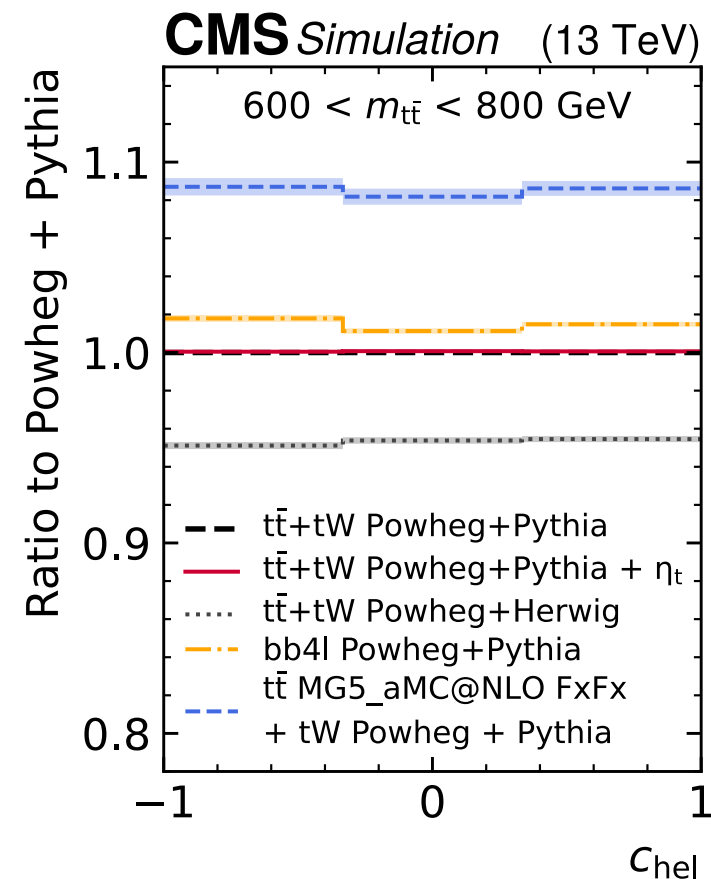
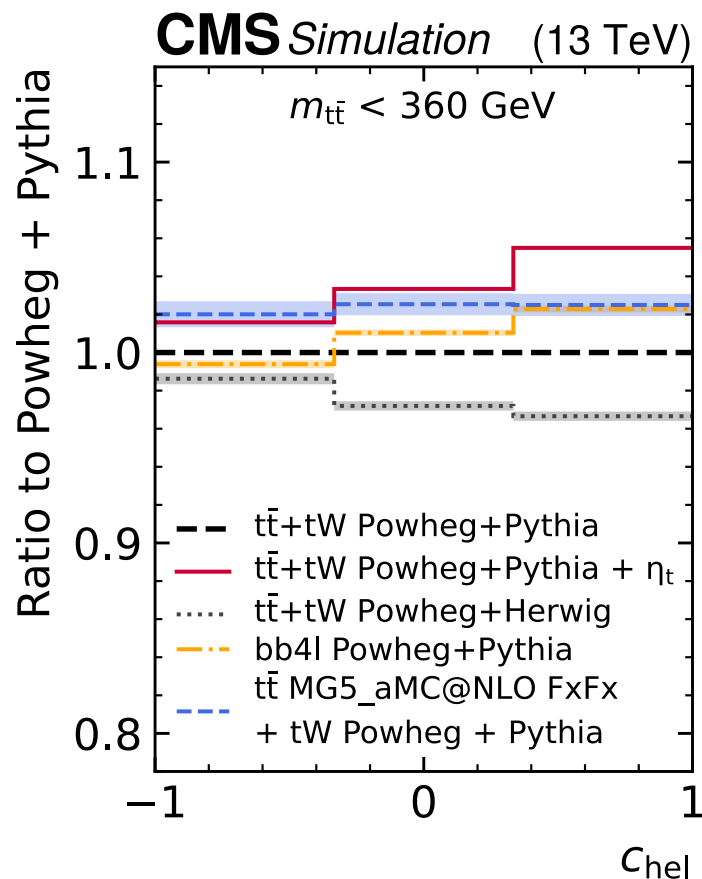
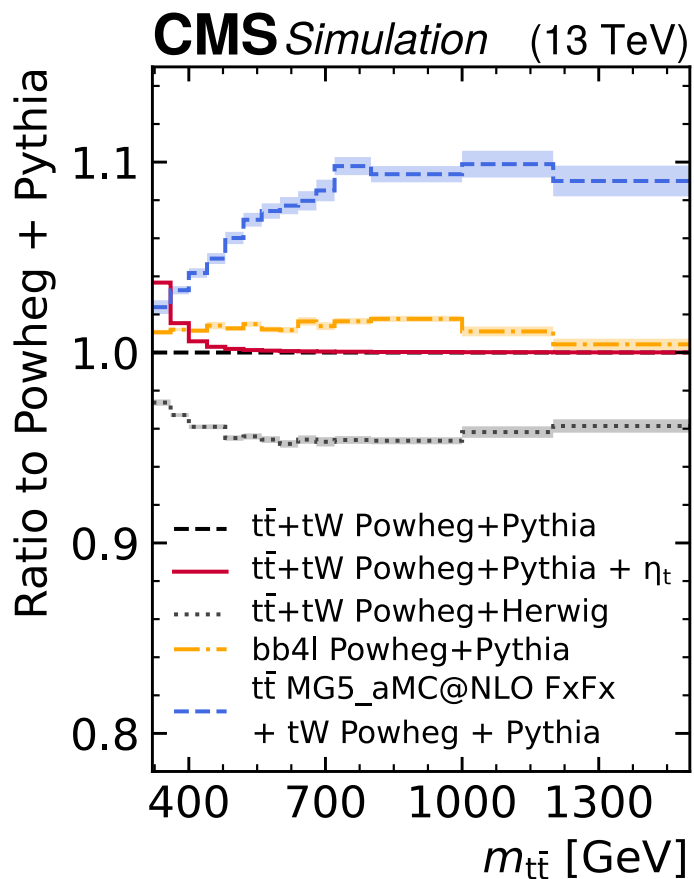

- First report about ATLAS results in EPS-HEP2025 in Marseille, France
- Celebration after toponium talks from ATLAS and CMS
- All the ATLAS&CMS management who attended EPS-HEP2025 listened the two talks
- Was one of the highlights for EPS-HEP2025

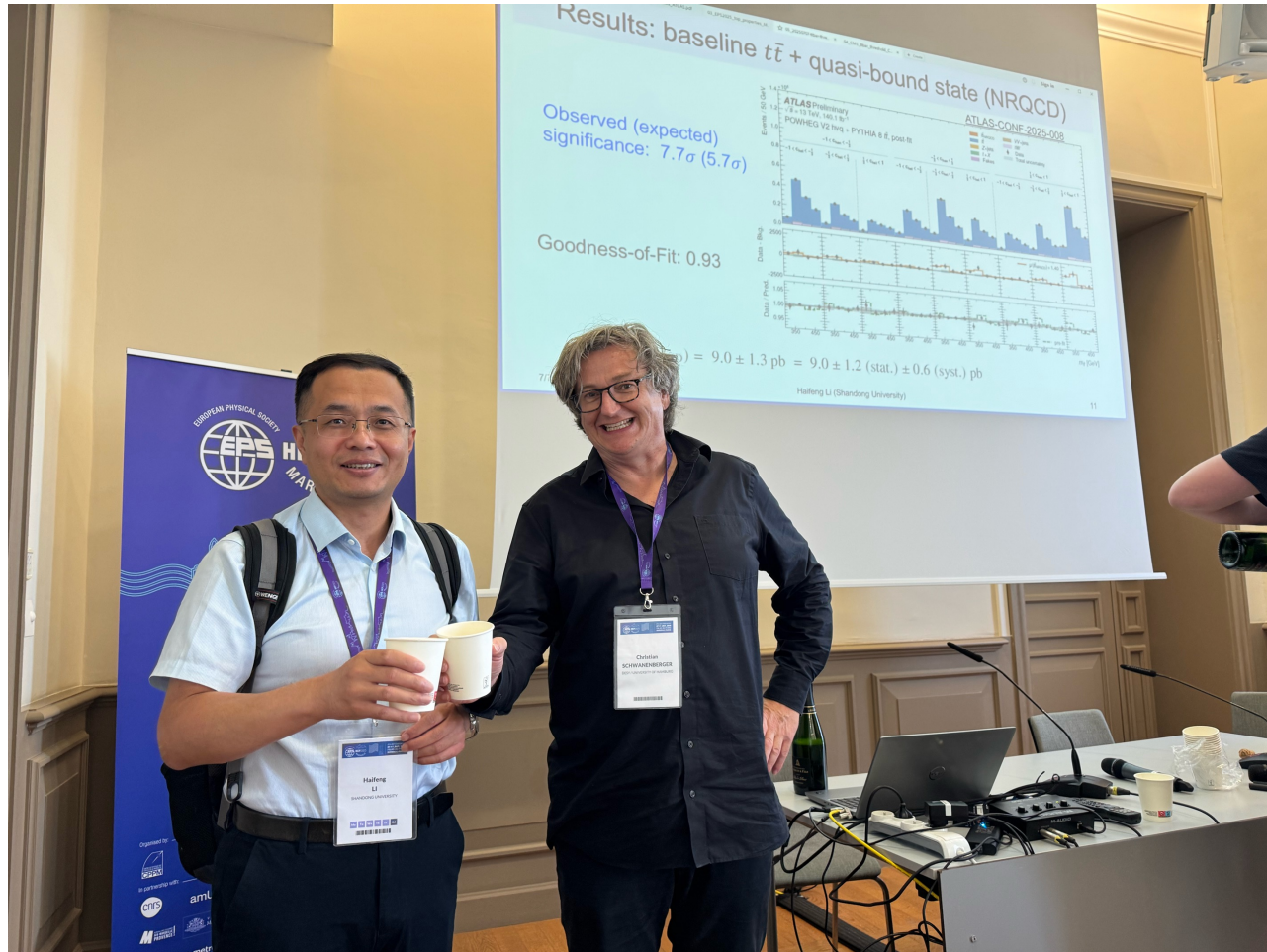

# CERN Press Release after the ATLAS talk in EPS-HEP2025

## Elusive romance of top-quark pairs observed at the LHC

The CMS and ATLAS experiments at CERN's Large Hadron Collider have observed an unforeseen feature in the behaviour of top quarks that suggests that these heaviest of all elementary particles form a fleeting union

8 JULY, 2025

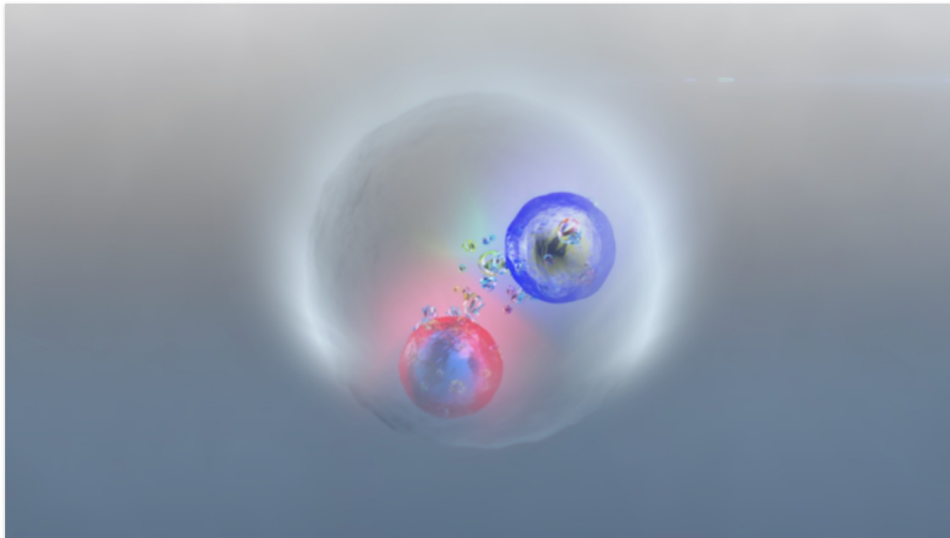

Artist's impression of the short-lived union of a top quark and a top antiquark formed by the exchange of gluons. (Image: D. Dominguez/CERN)

An unforeseen feature in proton-proton collisions previously observed by the CMS experiment at CERN's Large Hadron Collider (LHC) has now been confirmed by its sister experiment ATLAS. The result, reported yesterday at the European Physical Society's High-Energy Physics conference in Marseille, suggests that top quarks – the heaviest and shortest-lived of all the elementary particles – can momentarily pair up with their [antimatter](#) counterparts to produce a “quasi-bound-state” called toponium. Further input based on complex theoretical calculations of the strong nuclear force -- called quantum chromodynamics (QCD) -- will enable physicists to understand the true nature of this elusive dance.

An unforeseen feature in proton-proton collisions previously observed by the CMS experiment at CERN's Large Hadron Collider (LHC) has now been confirmed by its sister experiment ATLAS. The result, reported yesterday at the European Physical Society's High-Energy Physics conference in Marseille, suggests that top quarks – the heaviest and shortest-lived of all the elementary particles – can momentarily pair up with their antimatter counterparts to produce a “quasi-bound-state” called toponium.

# CMS Results: 1L

- 138 fb<sup>-1</sup> of pp collisions at 13 TeV
- Lepton + jets final state. e/μ and ≥4 jets

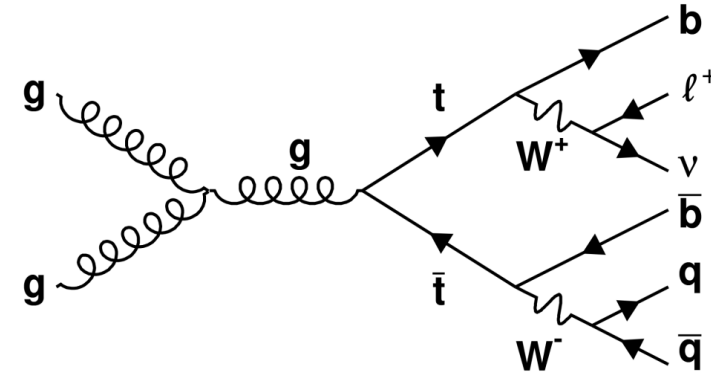

Total  $\eta_t$  cross section:  
 $5.1 \pm 0.9$  pb  
 Observed  
 significance:  $6.1 \sigma$

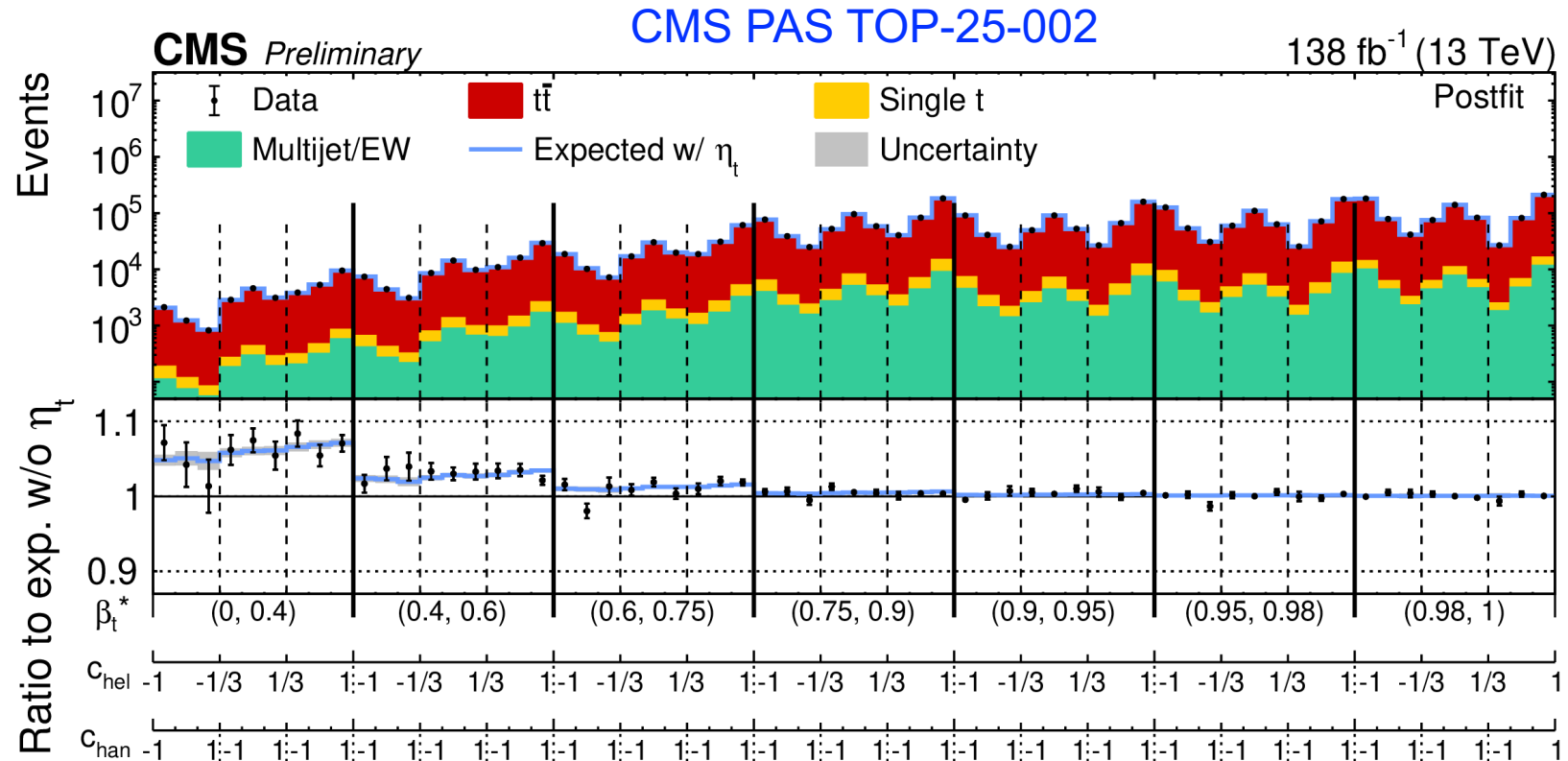

# Conclusions

- An excess of events is observed over the NNLO perturbative QCD prediction, with  **$8\sigma$  observed ( $8\sigma$  expected)** near the  $t\bar{t}$  production threshold by ATLAS with LHC Run 2 data. [[arXiv:2601.11780](https://arxiv.org/abs/2601.11780), submitted to Reports on Progress in Physics], [[ATLAS Physics Briefing](#)]
- This excess is consistent with **color-singlet, S-wave, quasi-bound  $t\bar{t}$  states** predicted by NRQCD with **cross-section of  $9.0 \pm 1.3$  pb**
- A more complete model from NRQCD calculation is used by ATLAS. Important advantage compared with recent CMS 2L results ([Rep. Prog. Phys. 88 \(2025\) 087801](#)) and also 1L CMS PAS TOP-25-002
- **Observation of toponium** opens a new field to study NRQCD with top quarks

Possible to do “hadron spectroscopy” with top quarks

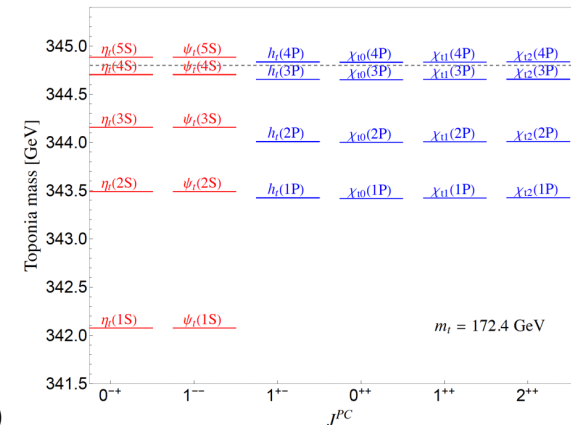

arXiv:2506.14552

# Backup

# Top Decays at LHC

- Decay (EW)

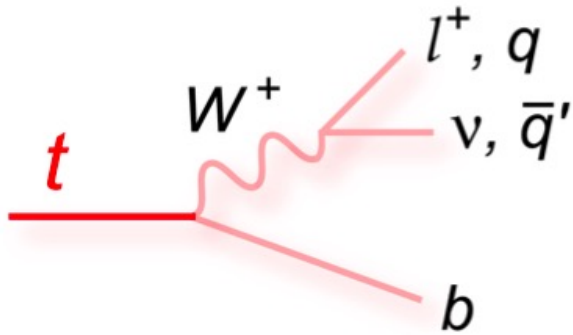

Complicated decay final states. Almost use all parts of the ATLAS detector

ttbar decay

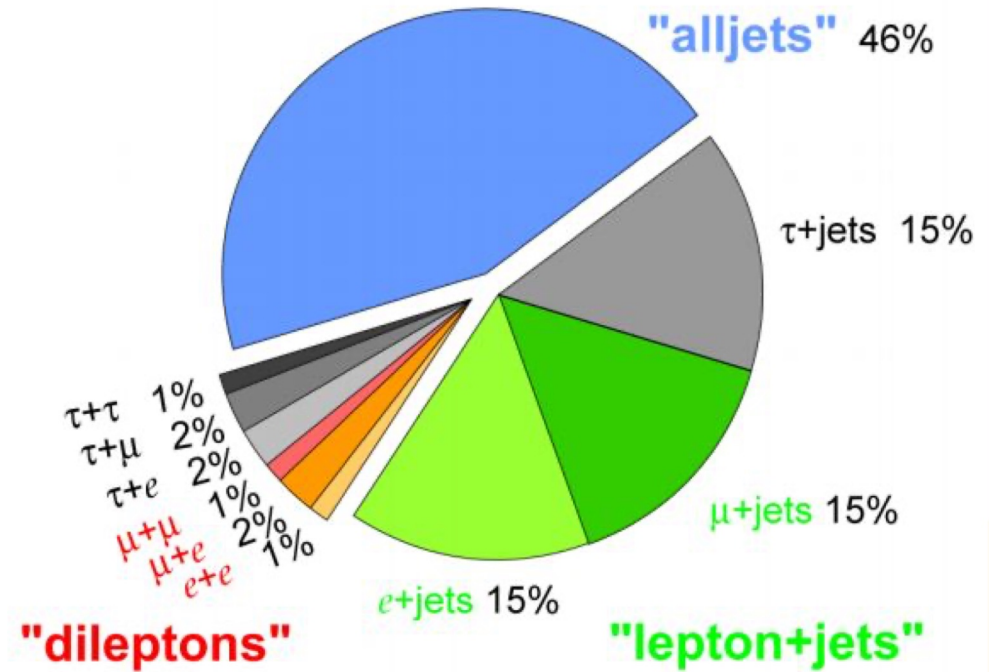

# Top quark pair reconstruction

*NIM A 736 (2014) 169-178*

- $t\bar{t}$  system reconstructed from the 2 leading b-jets, charged leptons, and  $\vec{p}_T^{\text{miss}}$  using:
  1. Invariant mass of  $\ell^+ \nu_\ell b$  and  $\ell^- \bar{\nu}_\ell \bar{b} = m_t = 172.5 \text{ GeV}$
  2. Invariant mass of  $\ell^+ \nu_\ell$  and  $\ell^- \bar{\nu}_\ell = m_W = 80.4 \text{ GeV}$
  3.  $\vec{p}_T^{\text{miss}}$  only from the two neutrinos:  $\nu_\ell$  and  $\bar{\nu}_\ell$
- Ellipse method used to geometrically solve constraint equations for neutrino momenta
- $m_t$  and  $m_W$  smeared if no solution found
- Solution found for 95% of events in SR - remaining discarded
- Resolution  $\frac{|m_{t\bar{t}}^{\text{reco}} - m_{t\bar{t}}^{\text{true}}|}{m_{t\bar{t}}^{\text{reco}}} \sim 22\%$  at threshold
- Alternative methods tested did not improve sensitivity

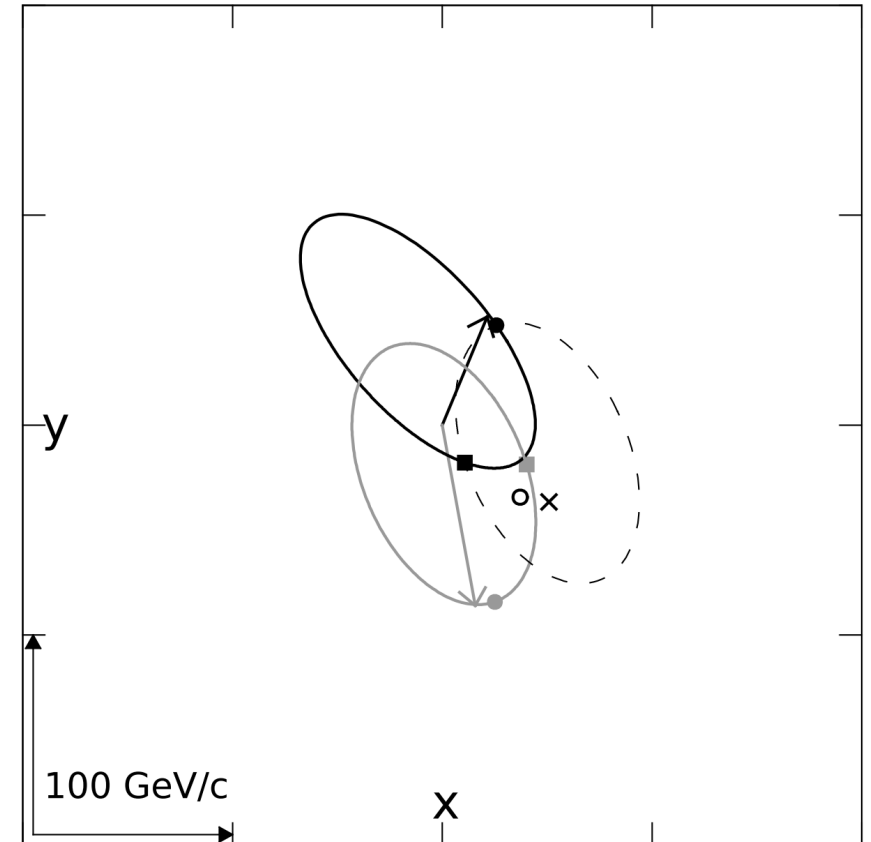

# ATLAS Paper Results

## What's new ([arXiv:2601.11780](https://arxiv.org/abs/2601.11780) vs ATLAS-CONF-2025-008)

- Updated treatment of 2  $\rightarrow$  6 NLO MC (bb4l)
- Improved systematic uncertainty treatment on the signal