



中国科学院大学
University of Chinese Academy of Sciences

Search for the electromagnetic dipole moments of short-lived particles

傅金林

中国科学院大学

Search for new physics at colliders

April 16-20, 2026, Nanjing University

Electric and Magnetic Dipole Moments

□ Definition in the ensemble of particles: $n, \Lambda, \Lambda_c^+, \tau^+$

$$\text{EDM: } \boldsymbol{\delta} = d\mu_B \mathbf{s}/2$$

$$\text{MDM: } \boldsymbol{\mu} = g\mu_B \mathbf{s}/2$$

Spin polarization vector:

$$\mathbf{s} = \text{Tr}[\rho\boldsymbol{\sigma}] = \frac{2}{\hbar} \langle \hat{\mathbf{S}} \rangle$$

Magneton: μ_B

Gyro-electric(magnetic) factor: $d(g)$

□ Interaction with EM field

$$\mathcal{H} = -\boldsymbol{\mu} \cdot \mathbf{B} - \boldsymbol{\delta} \cdot \mathbf{E}$$

$$\mathcal{H} \xrightarrow{\text{P,T}} \mathcal{H} = -\boldsymbol{\mu} \cdot \mathbf{B} + \boldsymbol{\delta} \cdot \mathbf{E}$$

Non-zero EDM is a signal of P/T violation, thus CP violation

Why EDM and MDM

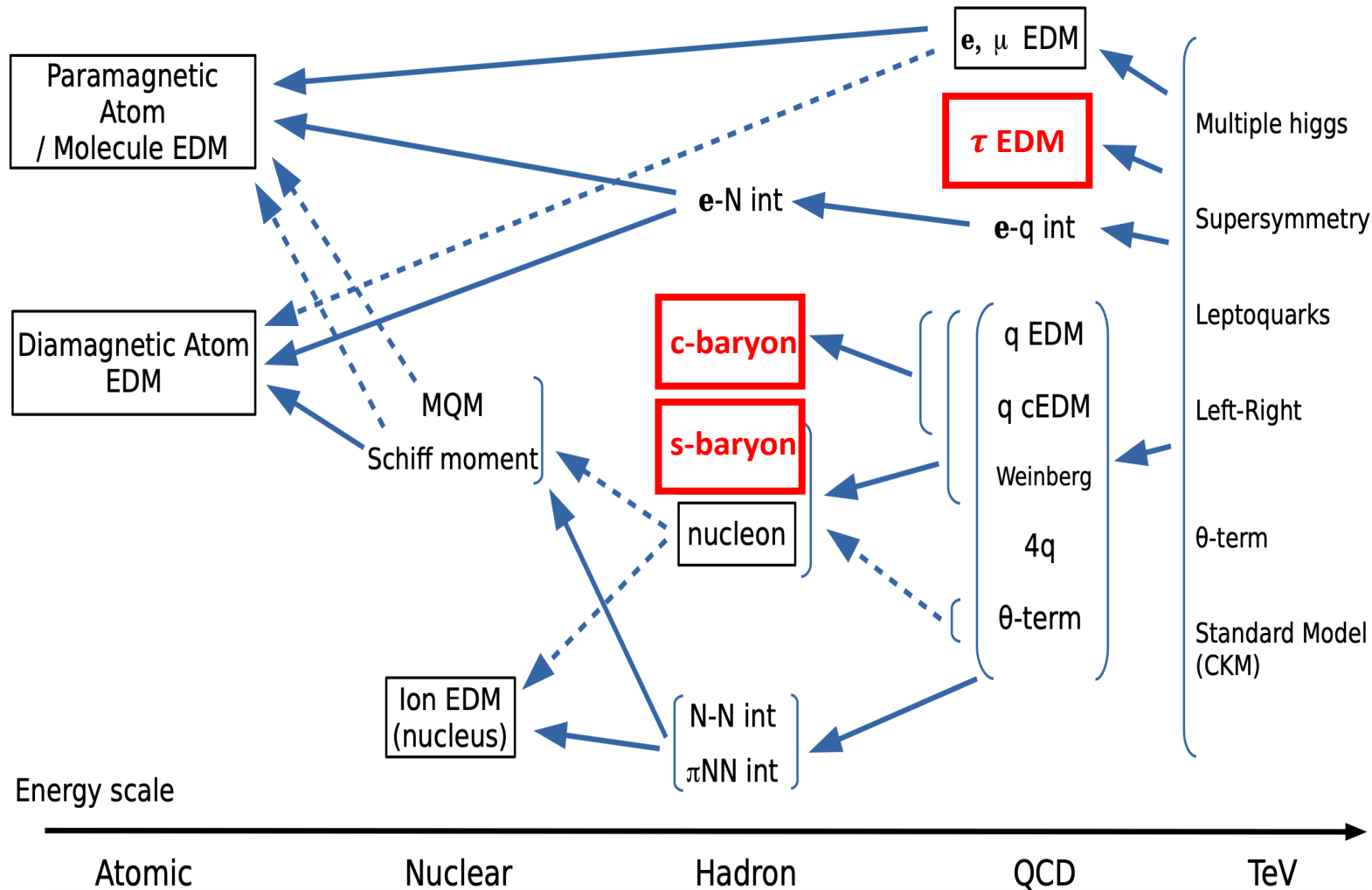

- ❑ CPV in CKM not sufficient for the missing antimatter in the Universe
- ❑ EDM as probe for new physics beyond SM
- ❑ Global EDM analysis needs experimental input from various systems

Why EDM and MDM

□ Elementary particle: e, μ, τ

$g = 2 + \text{QFT loop correction: } i.e \text{ muon } a=(g-2)/2 \text{ measurement}$

NP effects enhanced for heavy fermion $(m_\tau/m_\mu)^2 \sim 280$

□ Composite particle: $\Lambda, \Lambda_C^+, \Xi_C^+ \dots$

$g \neq 2$, depends on inner structures

Probe for baryon structure,
low-energy QCD physics, LQCD

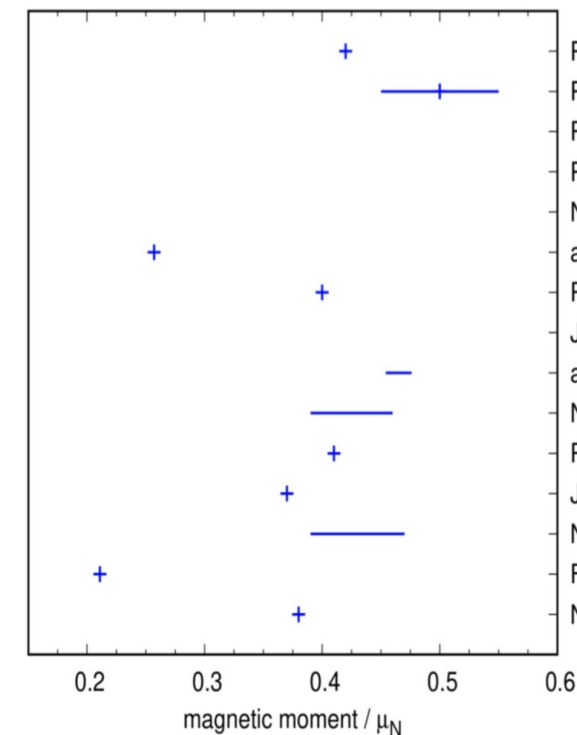
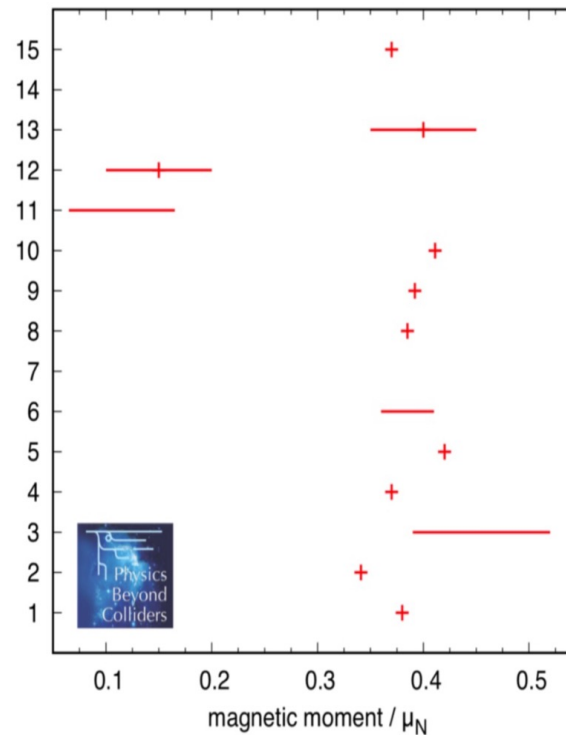

PLB 326 (1994) 303
 PRD 77 (2008) 114006
 PRD 65 (2002) 056008
 PRD 56 (1997) 7273
 NPA 735 (2004) 163
 arXiv:1209.2900
 PRD 81 (2010) 073001
 J Phys G35 (2008) 065001
 arXiv:0803.0221
 NPA 797 (2007) 131
 PRD 73 (2006) 094013
 J Phys G31 (2005) 141
 NPA 739 (2004) 69
 Few Body Syst 20 (1996) 1
 NIM B119 (1996) 259

Direct access to EDM and MDM

- EDM and MDM extracted from spin precession in EM field

$$\frac{d\mathbf{s}}{dt} = \mathbf{s} \times (\boldsymbol{\Omega}_{\text{MDM}} + \boldsymbol{\Omega}_{\text{EDM}} + \boldsymbol{\Omega}_{\text{TH}})$$

$$\boldsymbol{\Omega}_{\text{MDM}} = \frac{g\mu_B}{\hbar} \left(\mathbf{B} - \frac{\gamma}{\gamma + 1} (\boldsymbol{\beta} \cdot \mathbf{B}) \boldsymbol{\beta} - \boldsymbol{\beta} \times \mathbf{E} \right)$$

$$\boldsymbol{\Omega}_{\text{EDM}} = \frac{d\mu_B}{\hbar} \left(\mathbf{E} - \frac{\gamma}{\gamma + 1} (\boldsymbol{\beta} \cdot \mathbf{E}) \boldsymbol{\beta} - \boldsymbol{\beta} \times \mathbf{B} \right)$$

- Experimental requirement

- ✓ Sizable polarized particle source
- ✓ Enough flight length/intense EM field for precession
- ✓ Excellent detector for polarization measurement via angular analysis

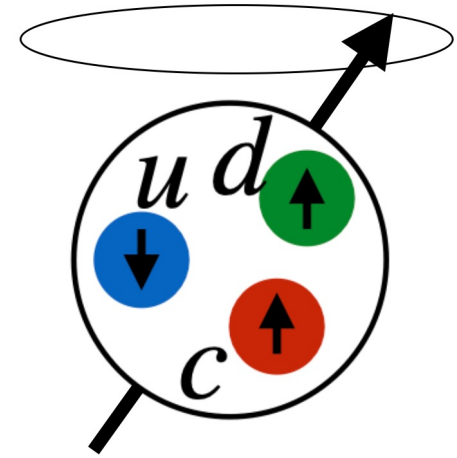

Significant challenge for short-lived particles, i.e. $\Lambda(10^{-10}\text{s}), \Lambda_c^+(10^{-13}\text{s}) \dots$

Λ EDM/MDM measurement at Fermilab

Magnet: 5m, 15Tm

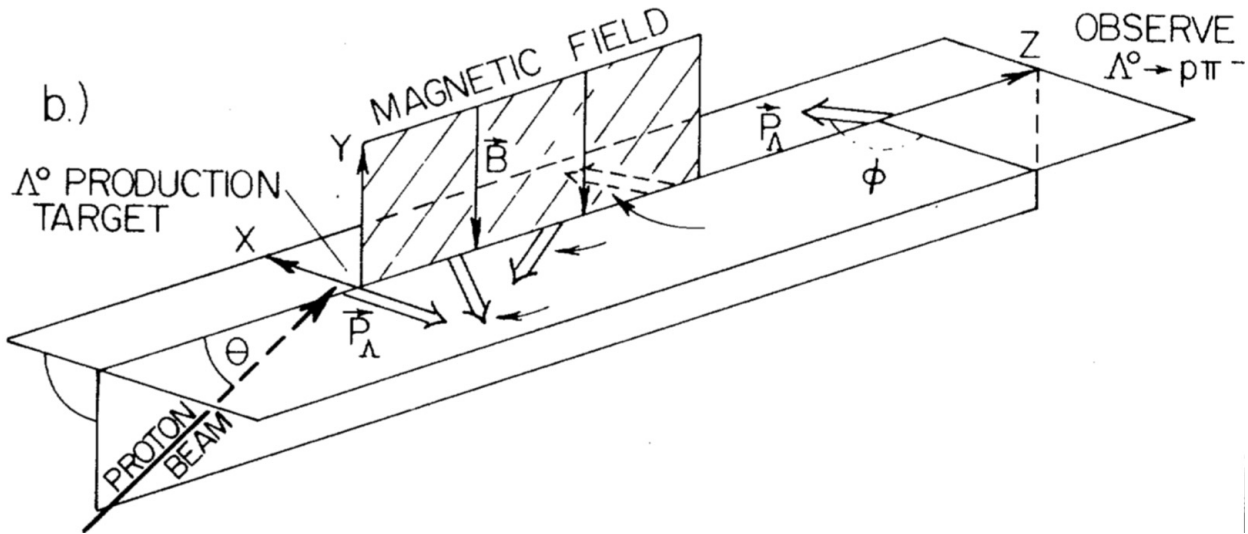

[Phys. Rev. D23 \(1981\) 814](#)

$$d_\Lambda < 1.5 \times 10^{-16} e \text{ cm @ 95\% C.L.}$$

[Phys. Rev. Lett. 41 \(1978\) 1348](#)

$$\mu_\Lambda = (-0.613 \pm 0.004) \mu_N$$

- ❑ Last direct measurement in 70's and 80's @Fermilab
- ❑ Fixed-target experiment with 300GeV proton beam on Be
- ❑ Reconstructed $3 \times 10^6 \Lambda \rightarrow p\pi^-$ decays
- ❑ Small transverse polarization $\sim 8\%$

EDM sensitivity depends on polarization and difficult to improve to $10^{-18} e \text{ cm}$

- ❑ No measurement for $\bar{\Lambda}$, hence no CPT test via MDM

Proposed measurement at LHCb

Run 1-2 detector

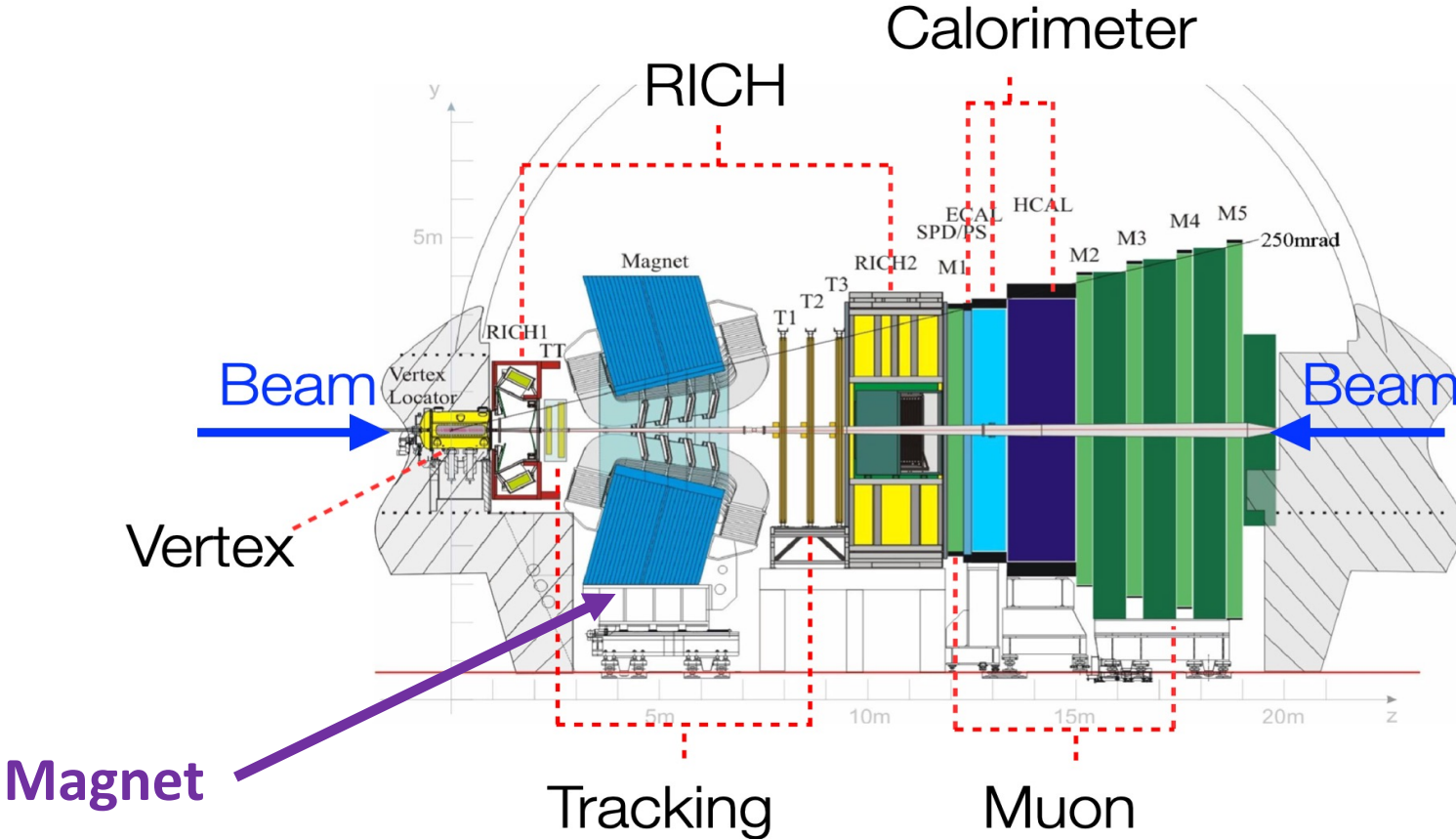

LHCb is a forward spectrometer

$$2 < \eta < 5$$

Proposed measurement at LHCb

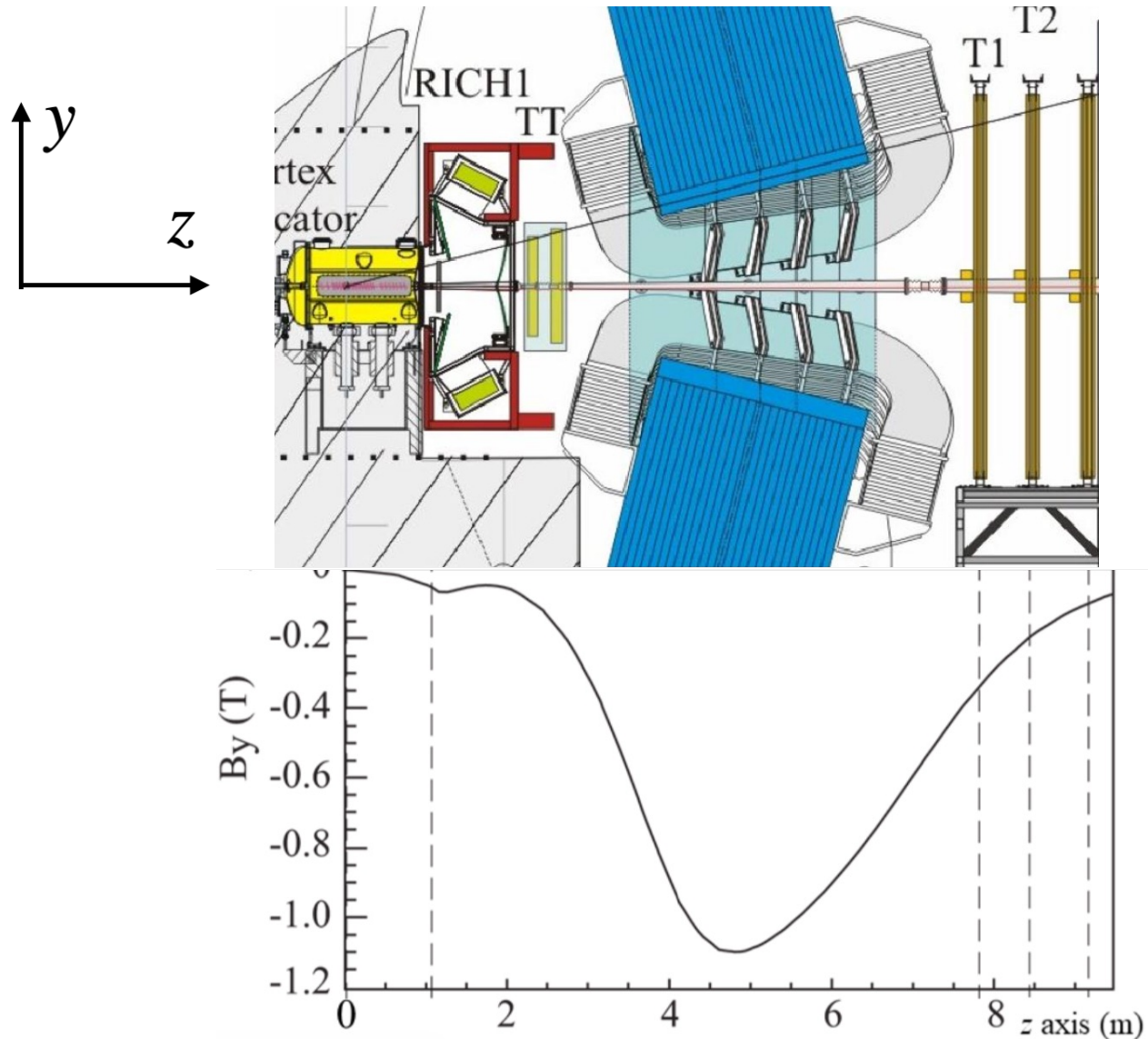

- ❑ Acceptance:
hor. ± 300 mrad, ver. ± 250 mrad
- ❑ Measured B field values stable
within $\sigma = \pm 0.07$ gauss
- ❑ $\int B dl = 4$ Tm

Proposed measurement at LHCb

EPJC77(2017)181

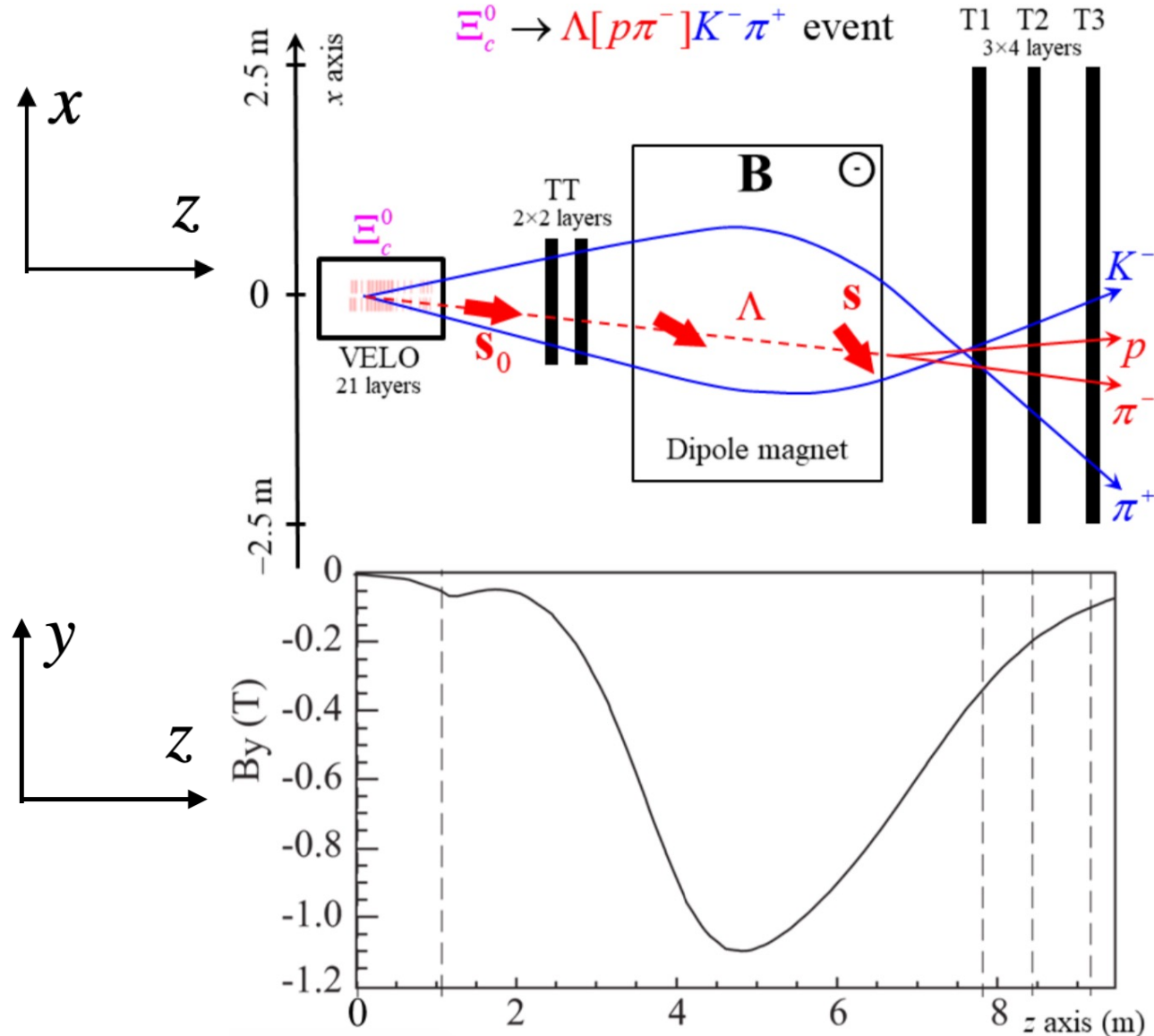

- ❑ Consider c baryon decays to charged final particles
- ❑ Sensitivity with $50fb^{-1}$ at LHCb
 $\delta(\Lambda) < 1.3 \times 10^{-18} e \text{ cm}$
 first $\bar{\Lambda}$ MDM measurement at similar precision
- ❑ Challenging: Λ decay reconstruction after magnet

Indirect access to hyperon EDM

PHYSICAL REVIEW D

VOLUME 47, NUMBER 5

1 MARCH 1993

CP violation in $J/\psi \rightarrow \Lambda \bar{\Lambda}$

Xiao-Gang He, J. P. Ma, and Bruce McKellar

Research Center for High Energy Physics, School of Physics, University of Melbourne, Parkville, Victoria 3052 Australia

(Received 19 November 1992)

We study CP violation in $J/\psi \rightarrow \Lambda \bar{\Lambda}$ decay. This decay provides a good place to look for CP violation. Some observables are very sensitive to the Λ electric dipole moment d_Λ and therefore can be used to improve the experimental upper bound on d_Λ . CP violations in the lepton pair decays of J/ψ and Υ are also discussed.

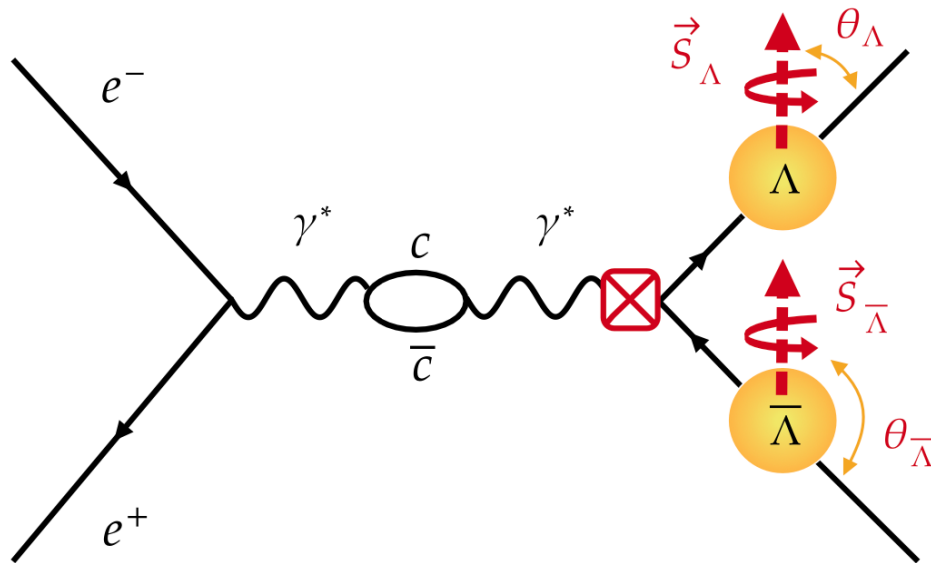

$$L_{c-\Lambda} = -\frac{2}{3M^2} ed_\Lambda (p_1^\mu - p_2^\mu) \bar{c} \gamma_\mu c \bar{\Lambda} i \gamma_5 \Lambda$$

$$H_T = \frac{2e}{3M^2} g_v d_\Lambda \quad \text{measure time-like dipole form factor with } q = m_{J/\psi}$$

X.G.He, J.P. Ma, Phys.Rev.D47(1993)1744

X.G.He, J.P. Ma, Phys.Lett.B 839(2023)137834

BESIII: a hyperon factory

Electromagnetic Calorimeter

CsI(Tl): L=28 cm
 Barrel $\sigma_E=2.5\%$
 Endcap $\sigma_E=5.0\%$

Muon Counter

RPC
 Barrel: 9 layers
 Endcap: 8 layers
 $\sigma_{\text{spatial}}=1.48$ cm

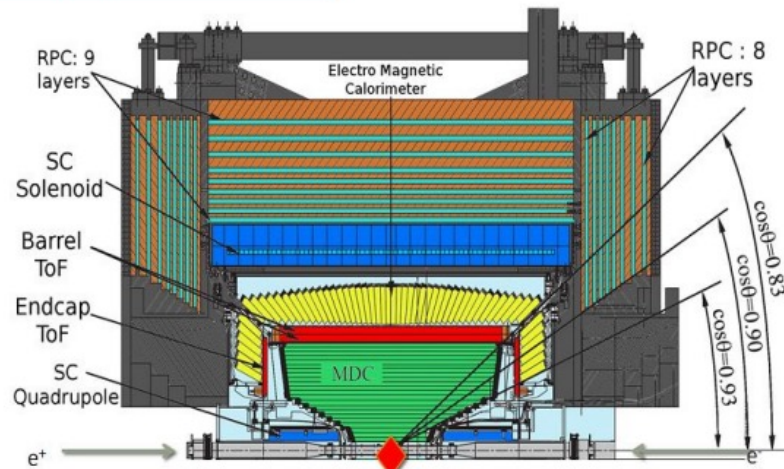

Main Drift Chamber

Small cell, 43 layer
 $\sigma_{xy}=130$ μm
 $dE/dx\sim 6\%$
 $\sigma_p/p=0.5\%$ at 1 GeV

Time Of Flight

Plastic scintillator
 $\sigma_T(\text{barrel})=80$ ps
 $\sigma_T(\text{endcap})=110$ ps
 (update to 65 ps with MRPC)

- ❑ 10 billion J/ψ collected at BESIII
- ❑ Millions of entangled hyperon-antihyperon pairs produced via $e^+e^- \rightarrow J/\psi \rightarrow B\bar{B}$
- ❑ Unique hyperon physics program due to known center-of-mass energy and spin correlation

Rare/Semileptonic/radiative decay

Hyperon-Nucleon interaction

CPV in hyperon decay

Hyperon EDM

Hyperon production

Hyperon EDM sensitivity

J. Fu, H.B.Li *et al.* Phys. Rev. D 108, L091301 (2023)

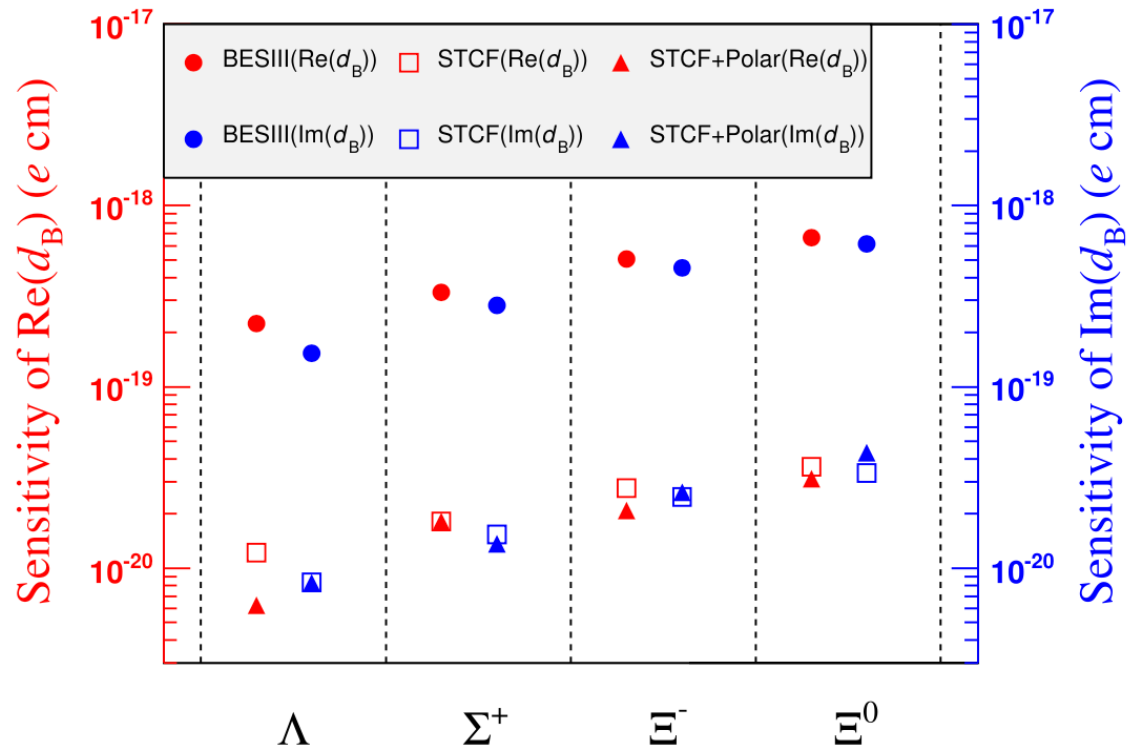

- Simultaneously determine all free parameters from full angular analysis

i.e. $J/\psi \rightarrow \Lambda \bar{\Lambda}$

Set of helicity angles

$$\xi^i = (\theta_\Lambda^i, \theta_p^i, \theta_{\bar{p}}^i, \phi_p^i, \phi_{\bar{p}}^i)$$

Fitted parameters

$$\vec{\lambda} = (P_L, G_2, F_A, H_T, \alpha_\Lambda, \alpha_{\bar{\Lambda}})$$

- Sensitivity at BESIII and STCF

$$10^{-19} \sim 10^{-21} \text{ e cm}$$

Λ EDM measurement at BESIII

arXiv:2506.19180, submitted to Science

- 3M $J/\psi \rightarrow \Lambda \bar{\Lambda}$ decays reconstructed, similar statistics as Fermilab in 1980s
- Preserve CP symmetry and a 3-order-of-magnitude improvement

$$Re(d_\Lambda) = (-3.1 \pm 3.2 \pm 0.5) \times 10^{-19} \text{ e cm},$$

$$Im(d_\Lambda) = (2.9 \pm 2.6 \pm 0.6) \times 10^{-19} \text{ e cm}.$$

$$-8.6 \times 10^{-19} < Re(d_\Lambda) < 3.3 \times 10^{-19} \text{ e cm},$$

$$-2.5 \times 10^{-19} < Im(d_\Lambda) < 7.2 \times 10^{-19} \text{ e cm},$$

$$|d_\Lambda| < 6.5 \times 10^{-19} \text{ e cm.} \quad @ 95\% \text{ CL}$$

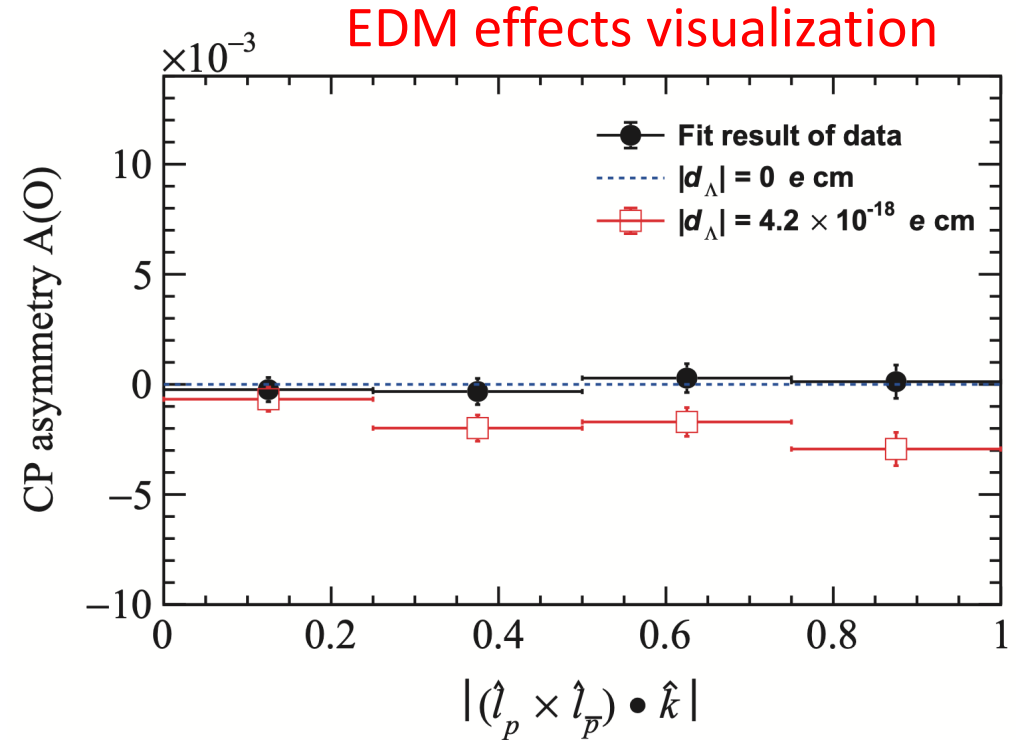

$$O \equiv (\hat{l}_p \times \hat{l}_{\bar{p}}) \cdot \hat{k} \propto Re(H_T G_2^*)$$

$$A(O) = \frac{N_{\text{event}}(O > 0) - N_{\text{event}}(O < 0)}{N_{\text{event}}(O > 0) + N_{\text{event}}(O < 0)}$$

Complementary to neutron EDM

- Stringent constraints on fundamental parameters $\bar{\theta}$ and d_s

Lattice QCD PRC103,015202 (2021) PRD98,091501(2018)

$$d_n = -(1.5 \pm 0.7) \times 10^{-16} \bar{\theta} e \text{ cm} - (0.20 \pm 0.01)d_u + (0.78 \pm 0.03)d_d + (0.0027 \pm 0.016)d_s$$

Valence quark model + QCD vacuum JHEP12,097(2012)

$$d_\Lambda = (-2.6 \pm 0.4) \times 10^{-16} \bar{\theta} e \text{ cm} + d_s$$

- Recent perturbative QCD analysis

d_Λ exhibits unique sensitivity to strange-quark CEDM $\tilde{d}_s < 1.4 \times 10^{-14} \text{ cm}$

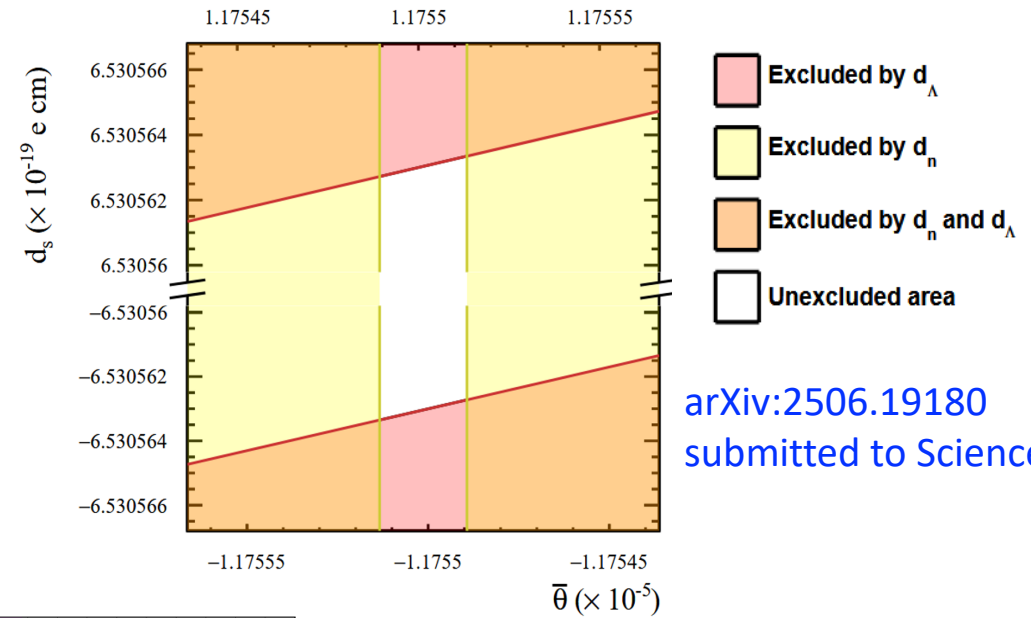

arXiv:2506.19180
submitted to Science

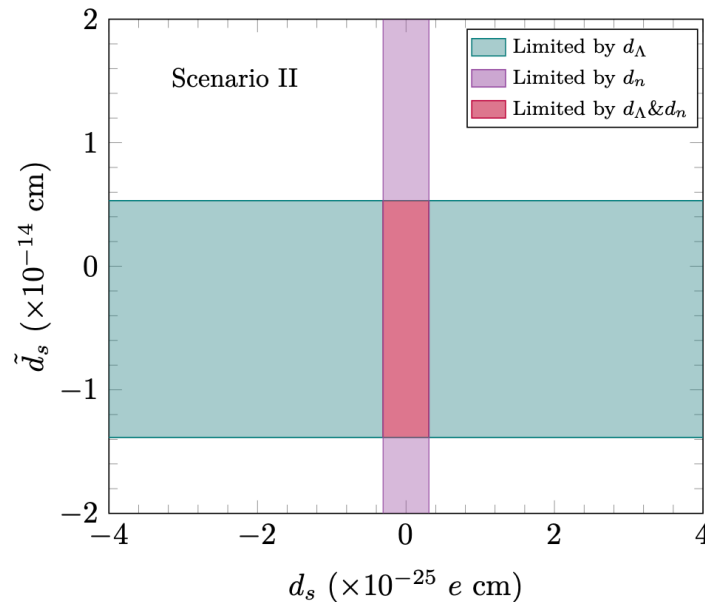

K.B. Chen, X.G. He, J.P. Ma, X.B. Tong,
Phys.Rev.Lett.136(2026)051902

Direct access to EDM and MDM

- EDM and MDM extracted from spin precession in EM field

$$\frac{ds}{dt} = \mathbf{s} \times (\boldsymbol{\Omega}_{\text{MDM}} + \boldsymbol{\Omega}_{\text{EDM}} + \boldsymbol{\Omega}_{\text{TH}})$$

$$\boldsymbol{\Omega}_{\text{MDM}} = \frac{g\mu_B}{\hbar} \left(\mathbf{B} - \frac{\gamma}{\gamma + 1} (\boldsymbol{\beta} \cdot \mathbf{B}) \boldsymbol{\beta} - \boldsymbol{\beta} \times \mathbf{E} \right)$$

$$\boldsymbol{\Omega}_{\text{EDM}} = \frac{d\mu_B}{\hbar} \left(\mathbf{E} - \frac{\gamma}{\gamma + 1} (\boldsymbol{\beta} \cdot \mathbf{E}) \boldsymbol{\beta} - \boldsymbol{\beta} \times \mathbf{B} \right)$$

- Experimental requirement

- ✓ Sizable polarized particle source
- ✓ Enough flight length/intense EM field for precession
- ✓ Excellent detector for polarization measurement via angular analysis

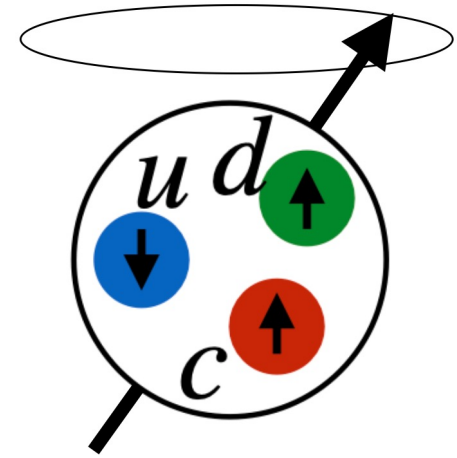

Significant challenge for short-lived particles, i.e. Λ_c^+ , Ξ_c^+ , τ^+ (10^{-13} s)

Polarized charm baryon source

- ❑ Polarized Λ_c^+ and Ξ_c^+ sources, produced from fixed-target pW collisions at LHC $\sqrt{s} \approx 110$ GeV
- ❑ Indication from Λ polarization: increases as a function of $x_F = P_L^*/\max(P_L^*)$

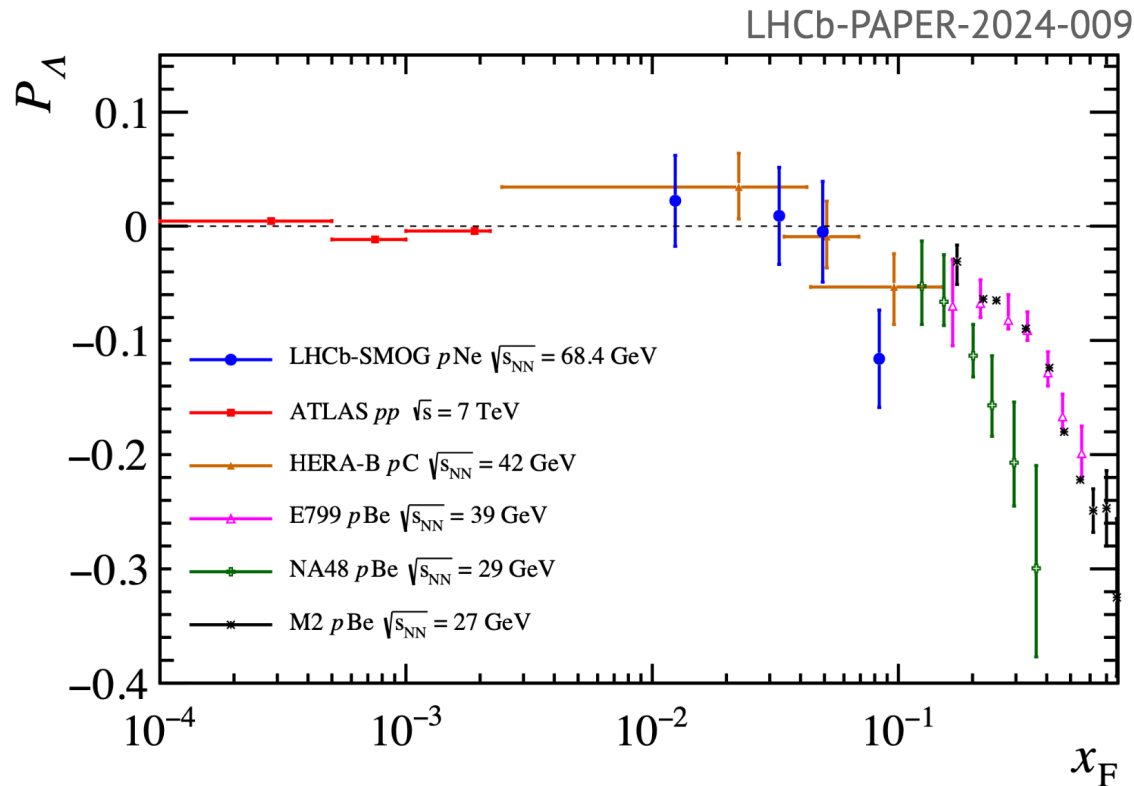

- ❑ Similar measurement progress at LHCb for Λ_c^+ with pp collisions and SMOG data

Channeling in bent crystal

- Incident positive charged particle can be trapped by potential well between crystal planes, if parallel to the planes (Lindhard 1965)

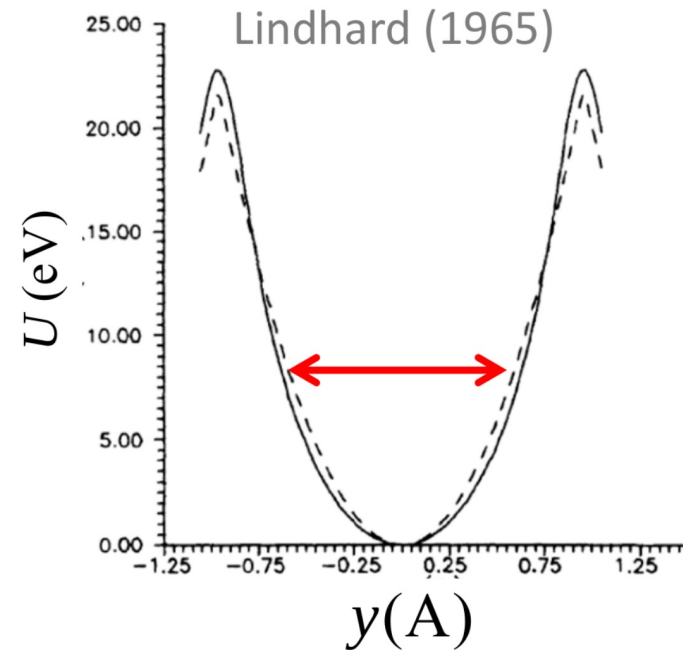
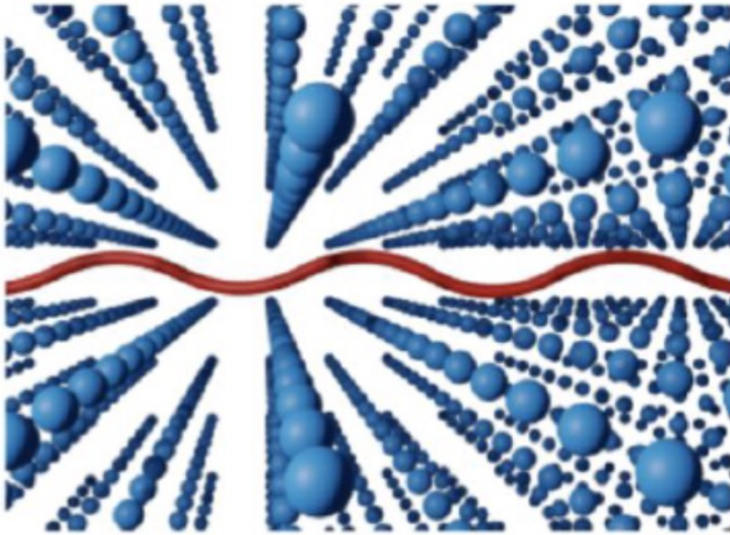

- Bent crystals used to steer high-energy particle beams and induce spin precession

Spin precession in bent crystal

- Channeled Λ_c^+ with $\langle p \rangle \sim 1.8 \text{ TeV}$ and bending angle $\theta_C = 7 \text{ mrad}$, $\beta\gamma\tau c \approx 7 \sim 10 \text{ cm}$
- Effective crystal electric field $E \sim 1 \text{ GV/cm}$

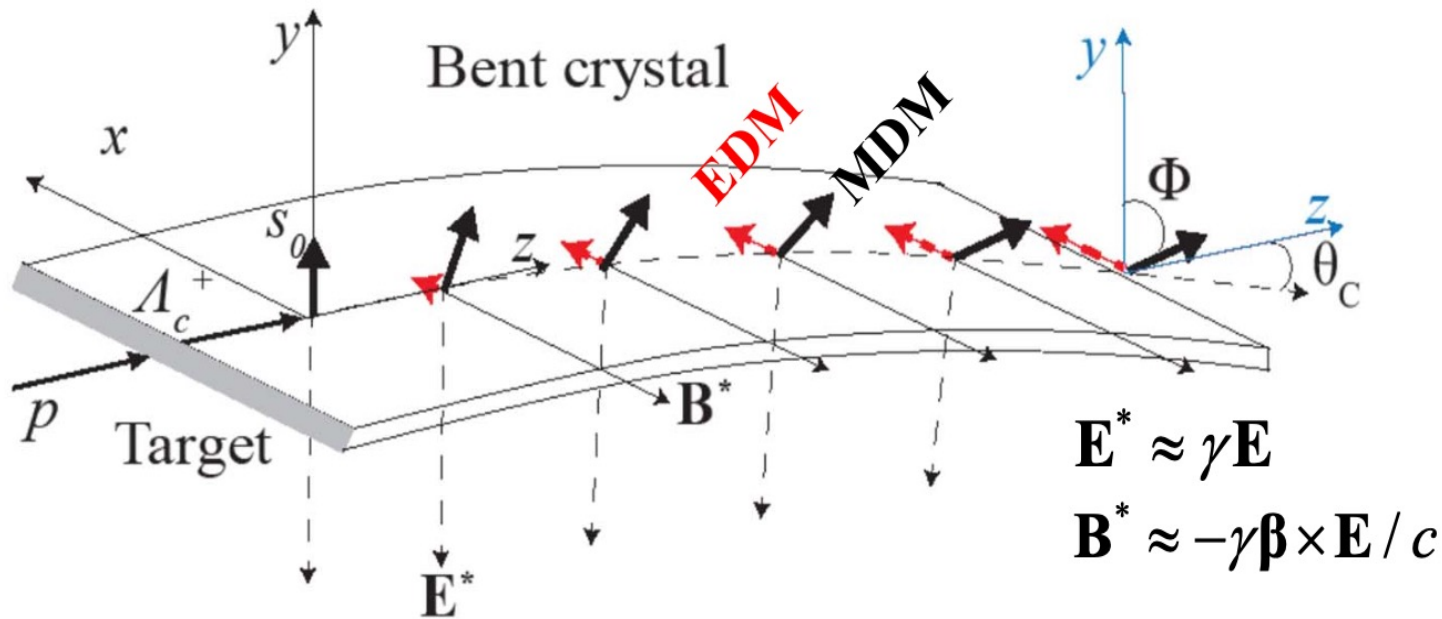

$$s'_x \approx s_0 \frac{d}{g-2} [1 - \cos \Phi]$$

$$s'_y \approx s_0 \cos \Phi$$

$$s'_z \approx s_0 \sin \Phi$$

$$\Phi \approx \frac{g-2}{2} \gamma \theta_C$$

- Measure final polarization via angular analysis of Λ_c^+ decay

TWOCRYST: proof-of-principle test at LHC

From R.Cai at [EPS2025](#)

Experimental setup

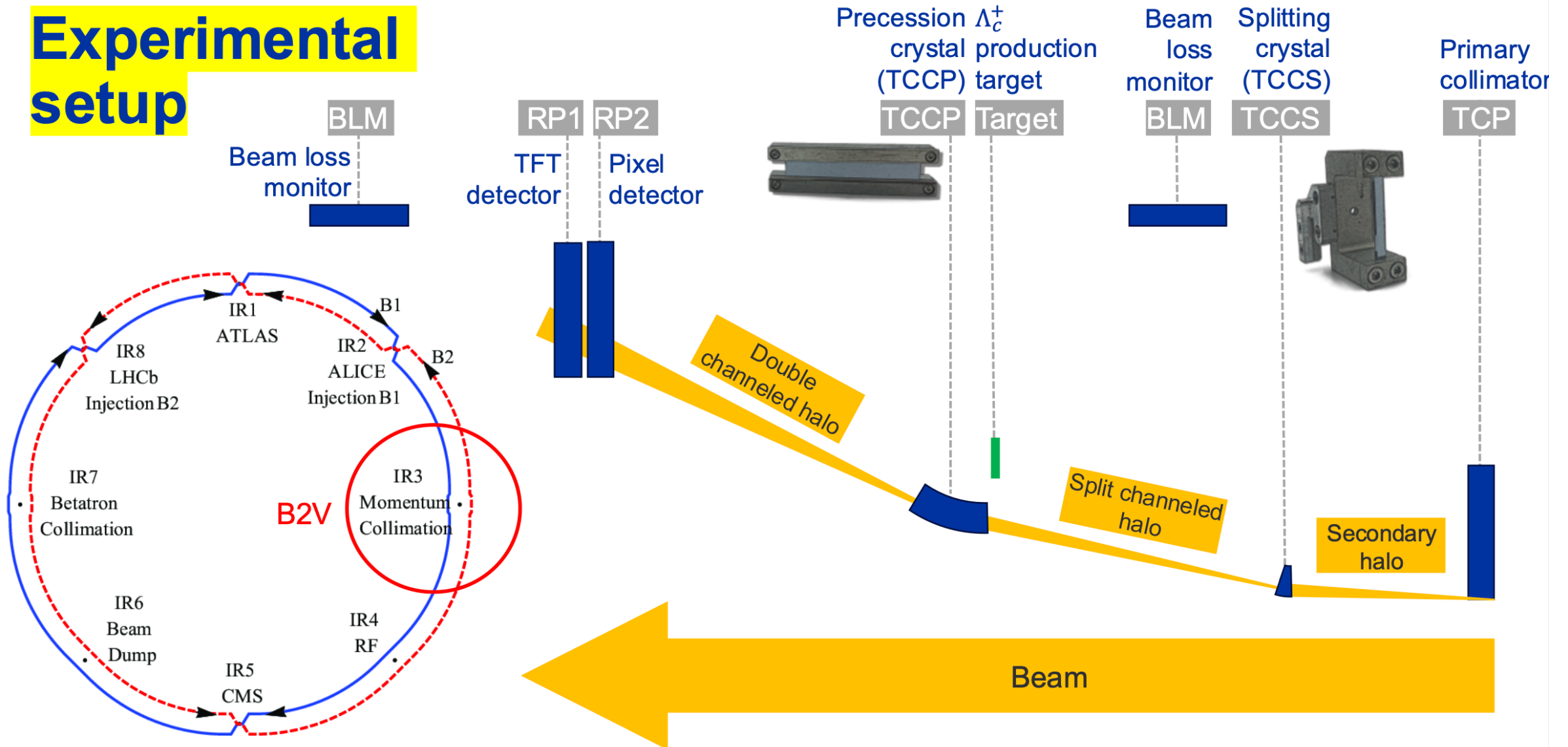

First experience - Success!

From R.Cai at [EPS2025](#)

Double channeling

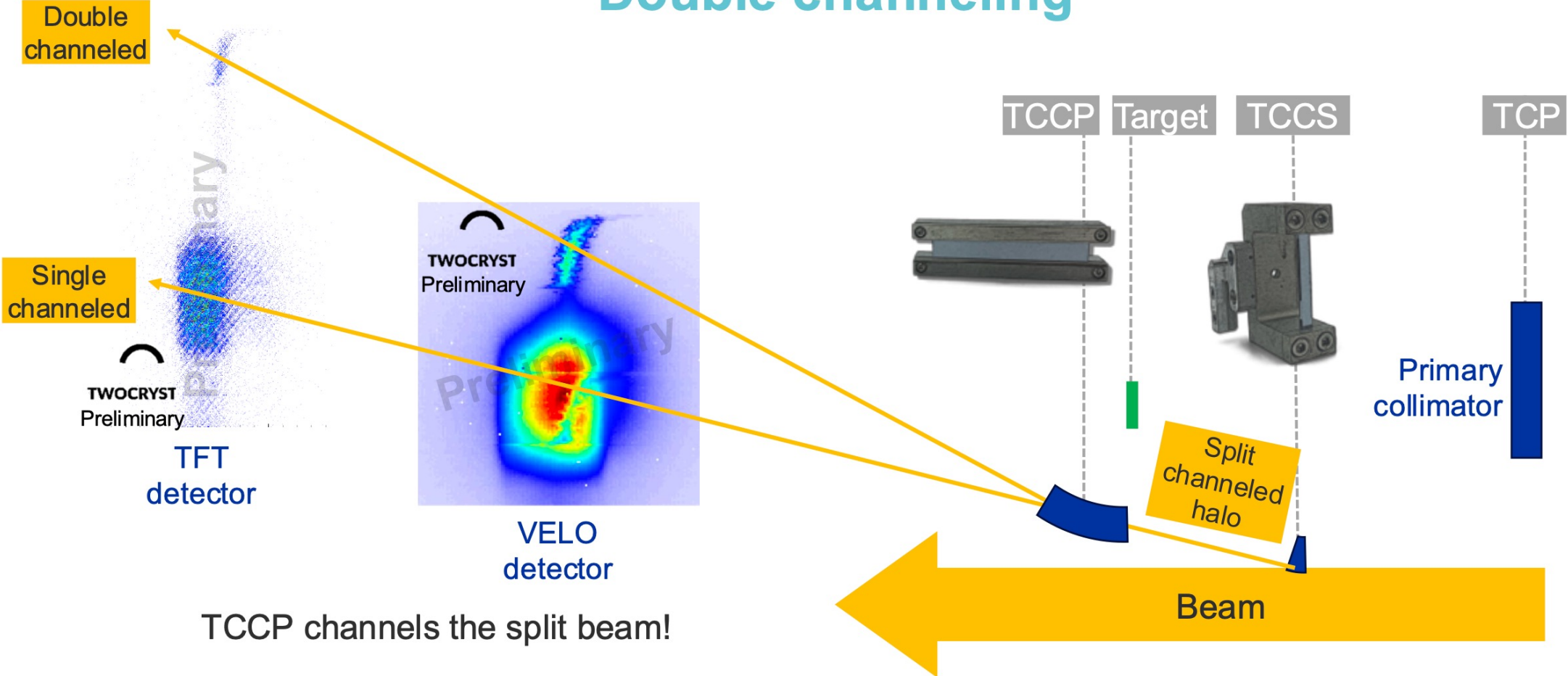

LHC MD 21-22 June

[CERN news](#)

Voir en [français](#)

Towards new physics with bent crystals

Double crystal channelling was observed for the first time at the LHC, a milestone for future short-lived particle research

29 AUGUST, 2025 | By [Insa Meinke](#)



Preliminary Results

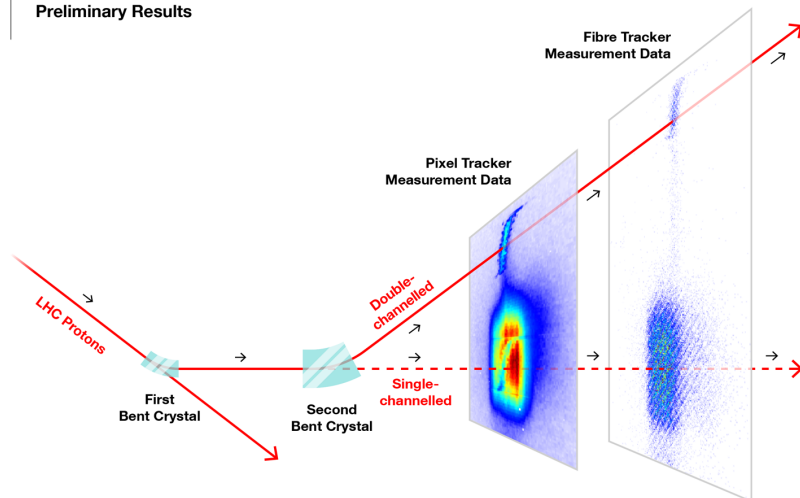

The ALADDIN experiment

<https://aladdin.web.cern.ch>

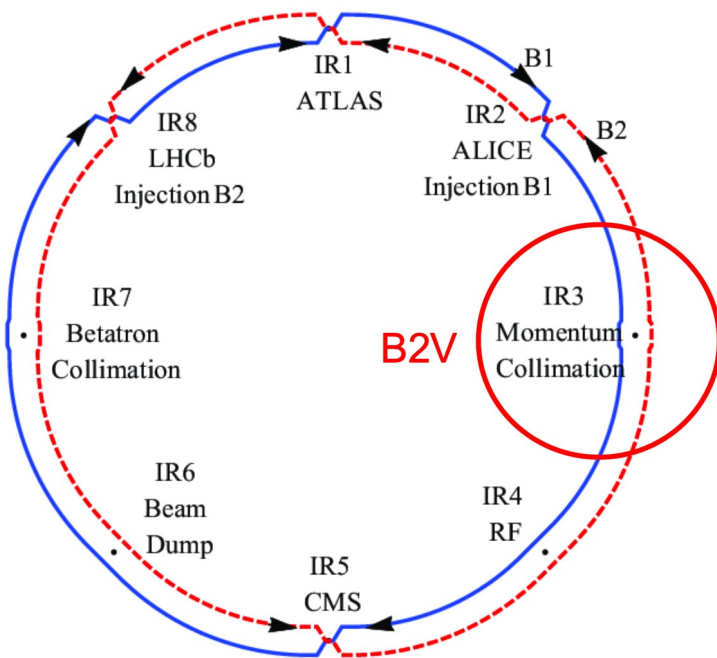
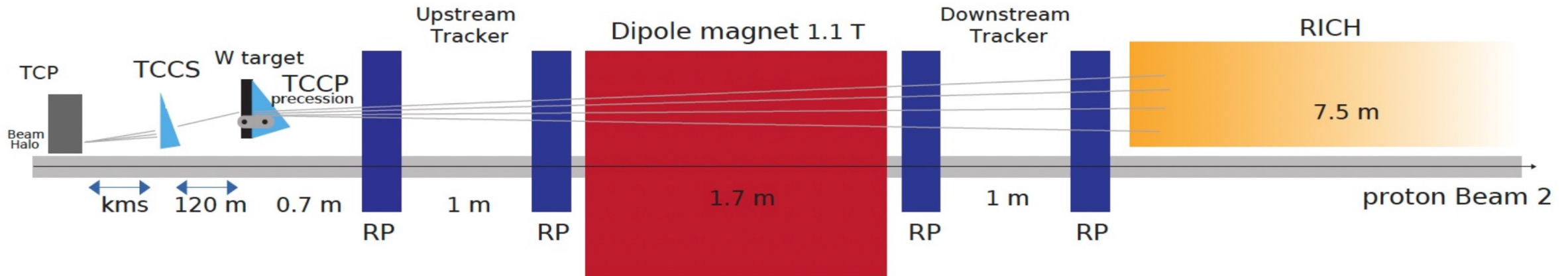

- First measurement of **MDM** and **EDM** in 2 year data taking 10^{13} Protons on Target
 Expected sensitivity: **MDM** $2 \times 10^{-2} \mu_N$, **EDM** $3 \times 10^{-16} e \text{ cm}$
 Tungsten target: 2 cm thickness
Spectrometer: track reconstruction
RICH: particle identification
- Charm production in very forward region $5 < \eta < 9$

The ALADDIN experiment

<https://aladdin.web.cern.ch>

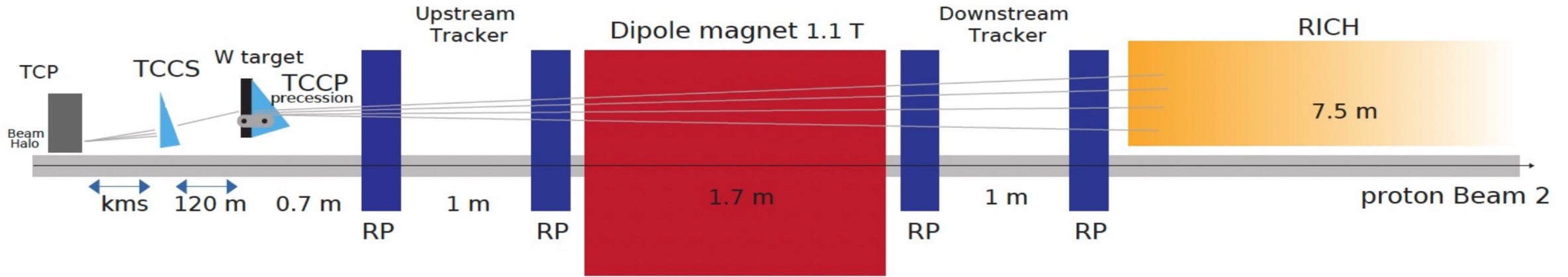

Further extended for τ EDM and $g-2$

[J. Fu et al. Phys. Rev. Lett. 123\(2019\)011801](#)

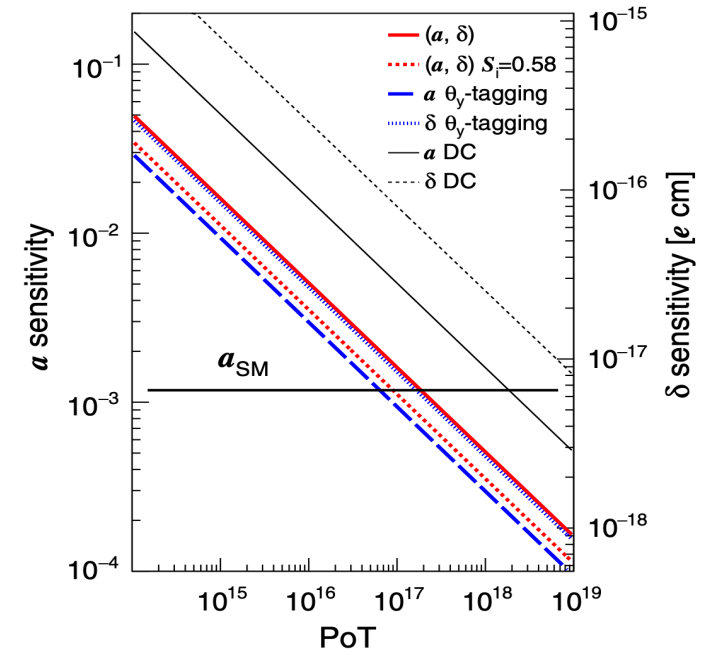
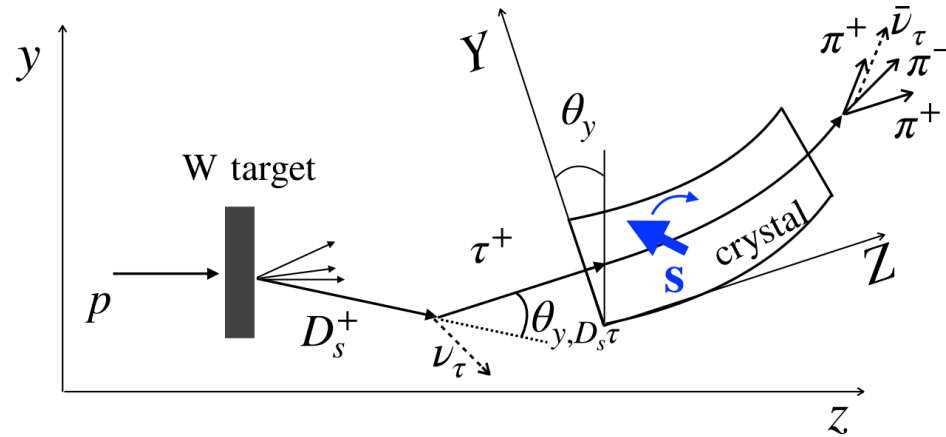
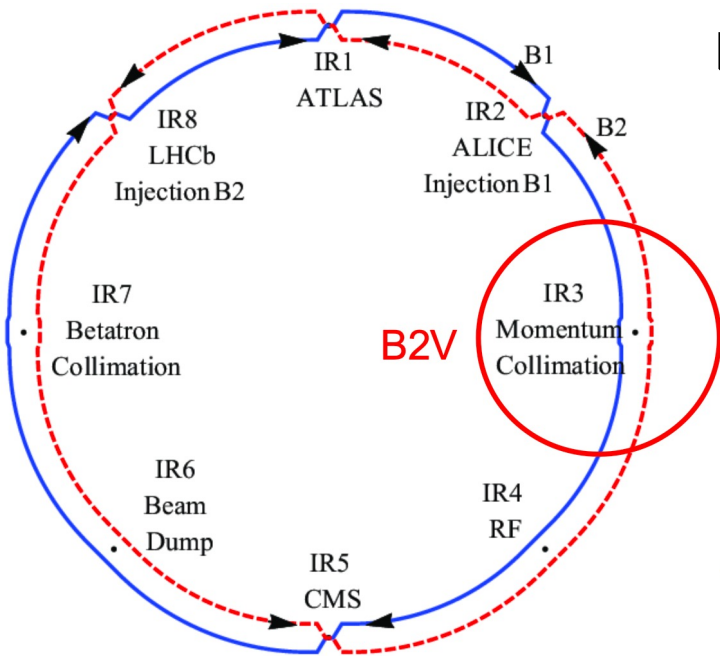

Summary

- ❑ Extensive EDM and MDM searches are ongoing at BESIII and LHCb
- ❑ ALADDIN: a new proposal for charm baryon and tau, presenting a challenging but unique opportunity to test SM and search for new physics, aim to start data taking in Run4

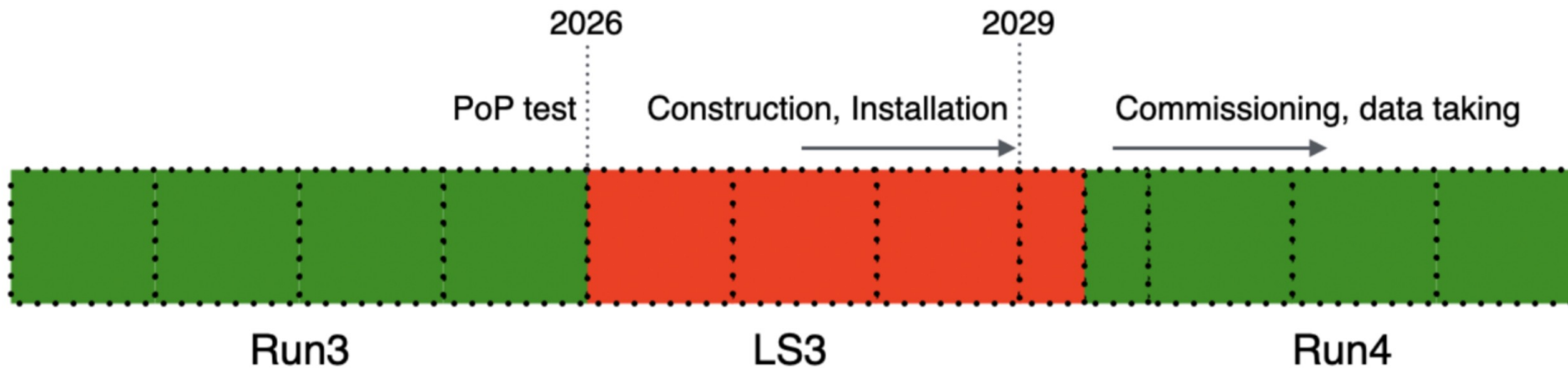

Bent crystal testbeam at CERN SPS

- ❑ Two silicon crystals: splitting crystal (TCCS) and precession crystal (TCCP)
- ❑ Produced by INFN Ferrara (A.Mazzolari), tested at SPS H8 with 180GeV/c hadron beam (Aug. 2023)

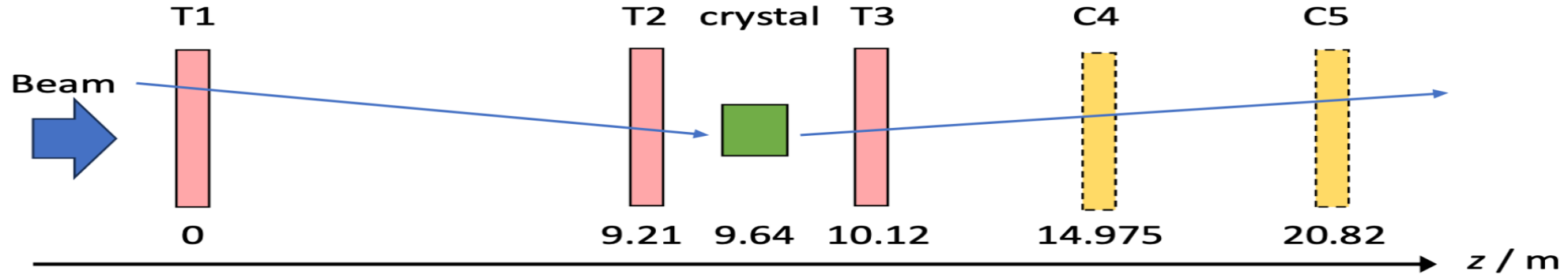

TCCS: 4mm, 50 μ rad channeling eff. 60%

TCCP: 70mm, 7mrad channeling eff. 16%

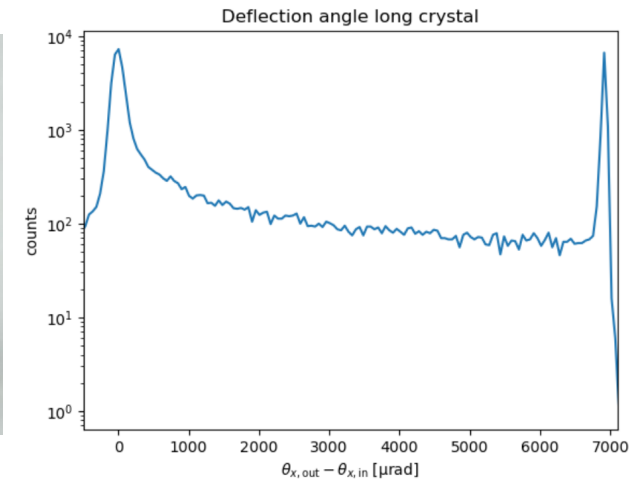
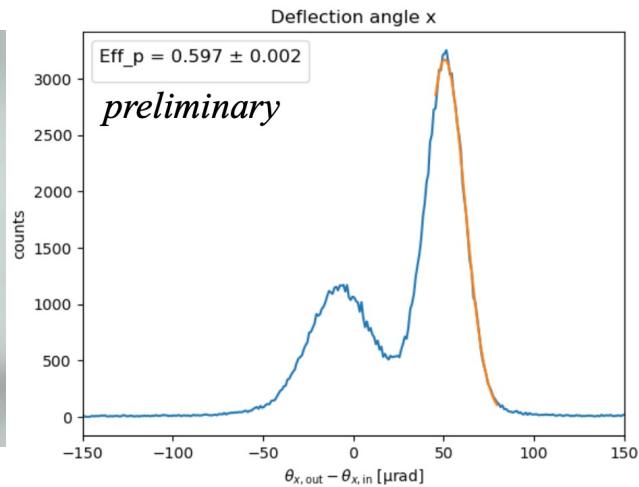
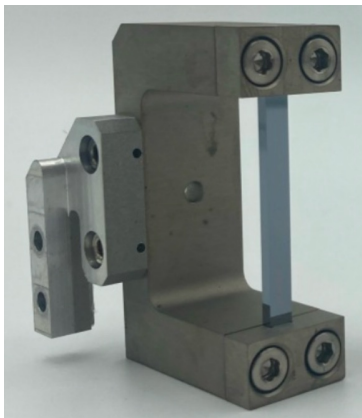

Detectors

From R.Cai at [EPS2025](#)

Fibre tracker
Recovered from
ATLAS-ALFA

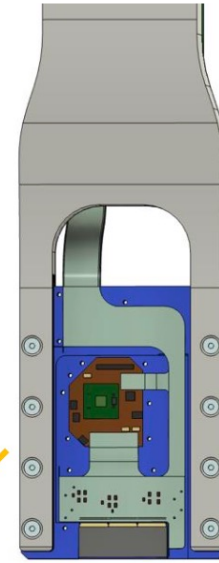
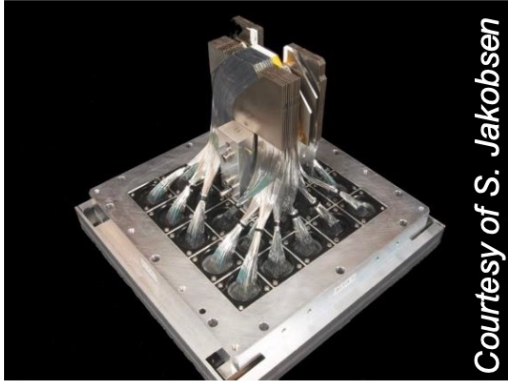

VELO silicon
pixel detector

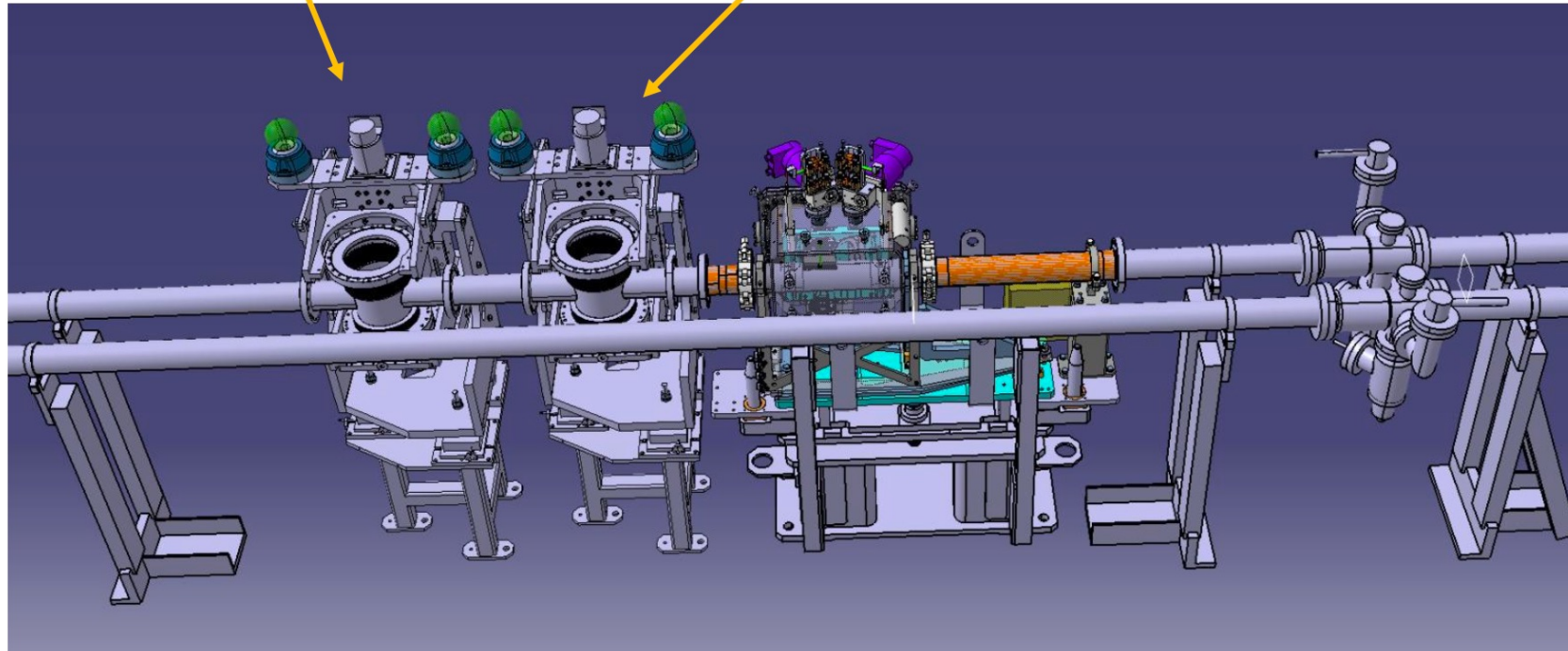

Roman Pot and Pixel detector

ATLAS-ALFA Roman Pot station



Detector housing

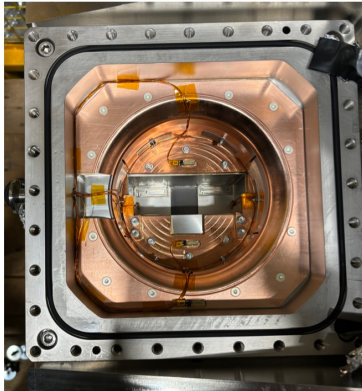

LHCb VELO module assembled

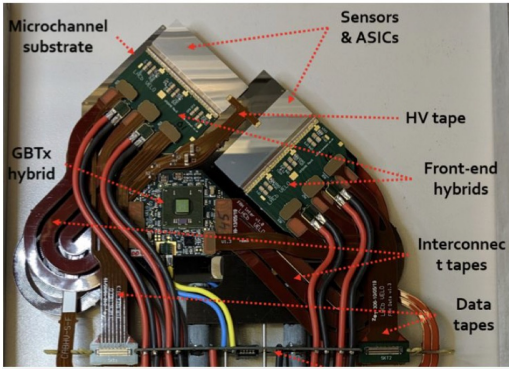

CMS-TOTEM top part and new closing flange

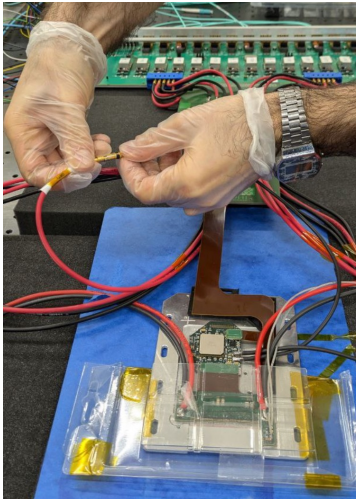
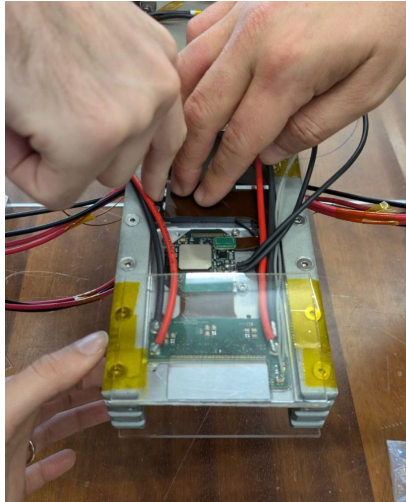
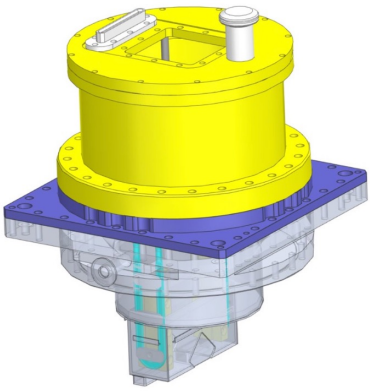

Spectrometer

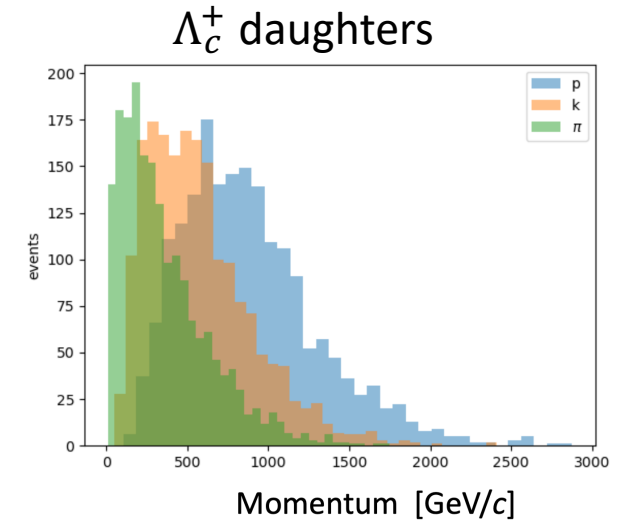
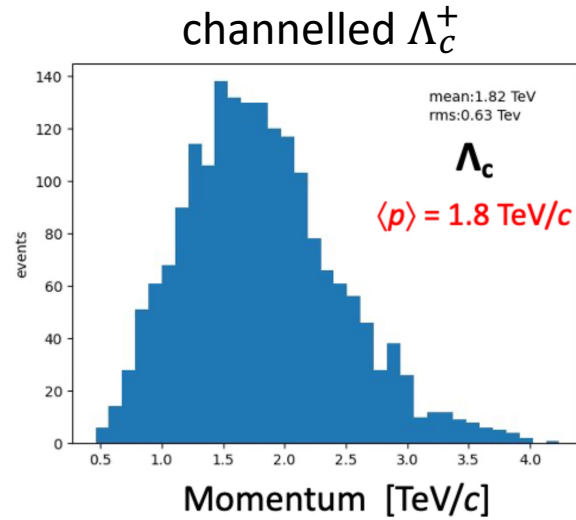
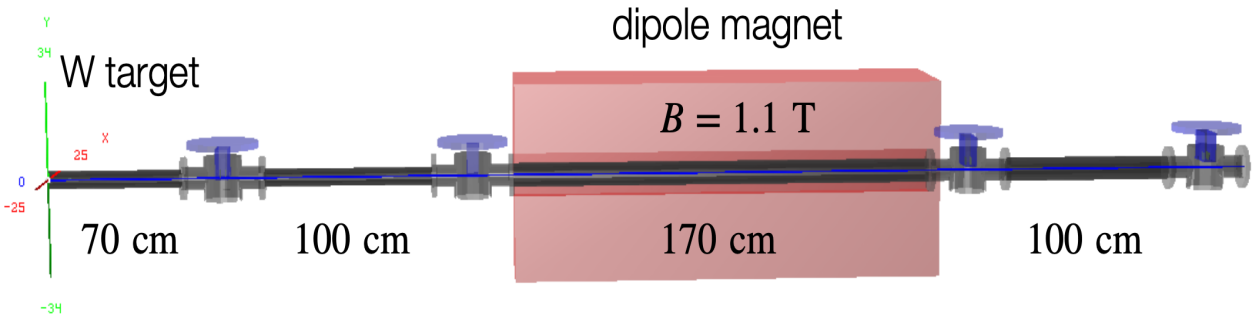

- ❑ Cover the pseudorapidity $5 < \eta < 9$
- ❑ VELO pixel sensors in four Roman Pots, two layers for each RP
- ❑ A dipole magnet MCBWV available in situ: $B=1.1\text{T}$ and $L=1.7\text{m}$

Momentum resolution

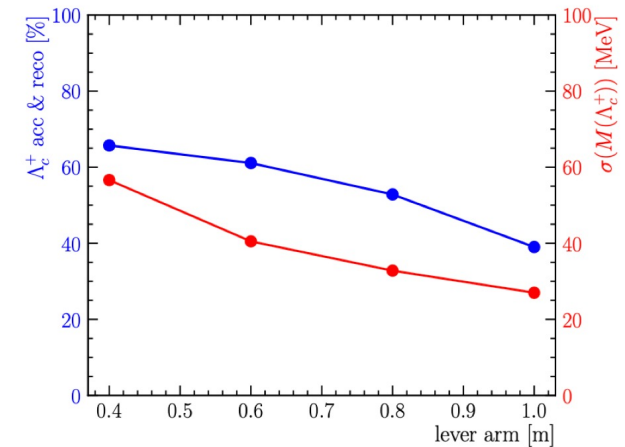
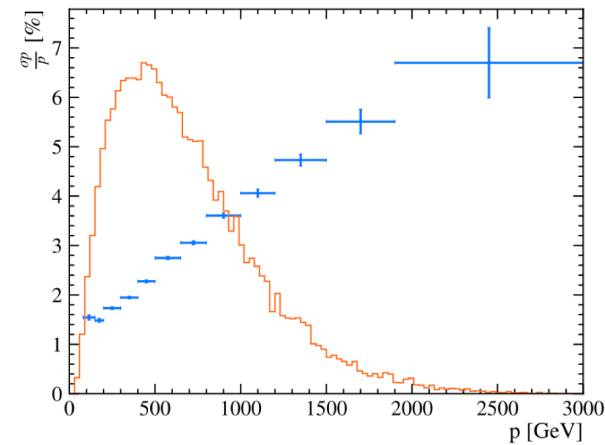

RICH

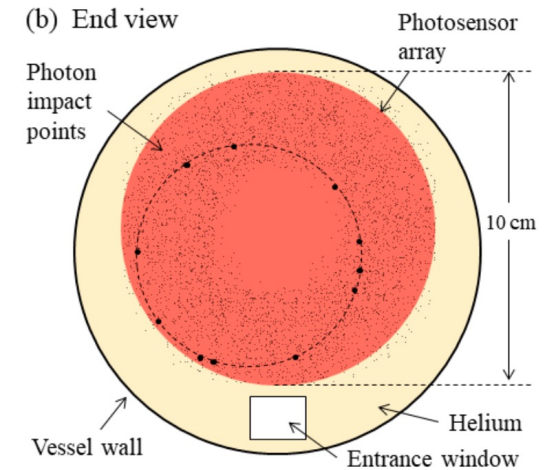
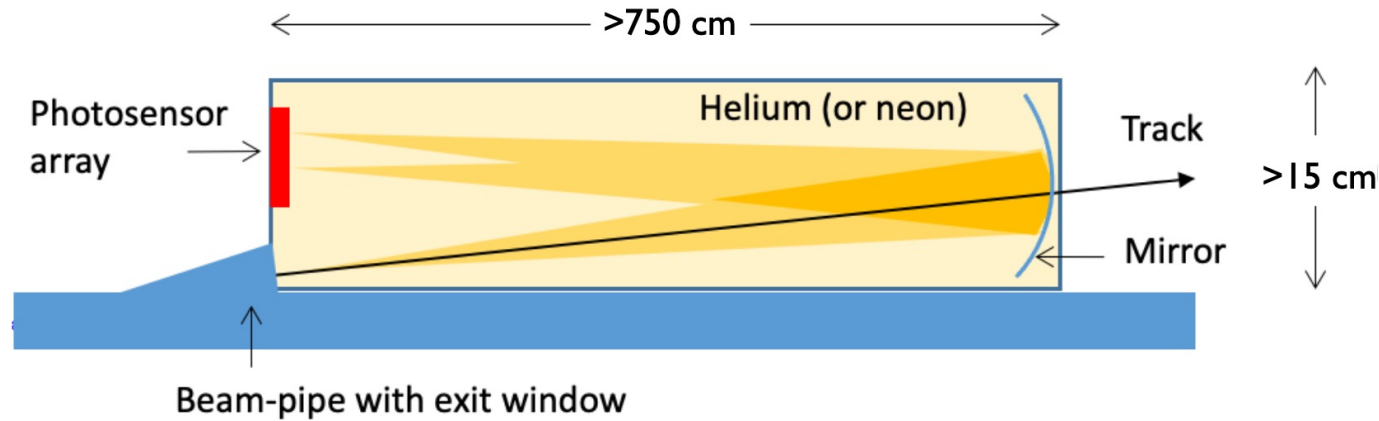

- ❑ High-momentum charged particles at 1TeV/c range
- ❑ Helium or Neon as radiator gas
- ❑ SiPM for photon readout
- ❑ Excellent background rejection can be achieved

$$N_{\sigma} = \frac{|m_1^2 - m_2^2|}{2p^2 (\sigma_{\theta}/\sqrt{N_{pe}}) \sqrt{n^2 - 1}}$$

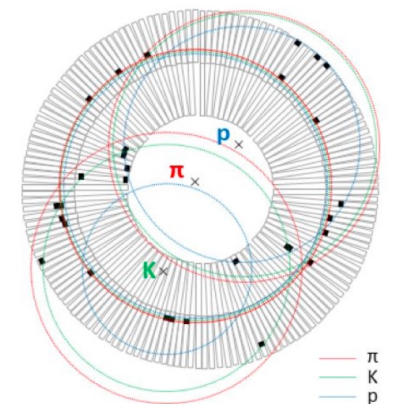
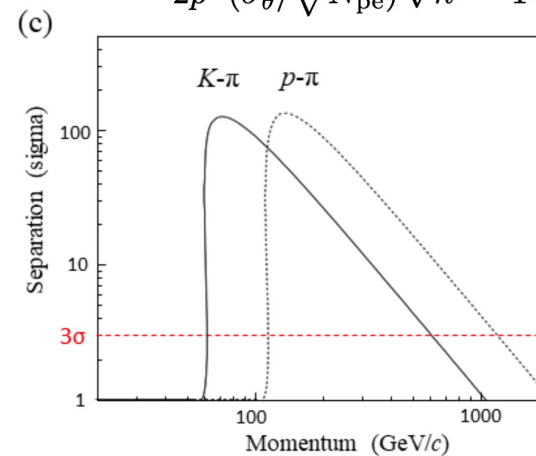

TWOCRYST Collaboration

CERN

O. Aberle, F. Alessio, C. Antuono, G. Arduini, M. Calviani, V. Coco, M. D'Andrea, Q. Demassieux, K. Dewhurst, M. Di Castro, L. Esposito, M. Ferro-Luzzi, H. Havlikova, P. Hermes, S. Jakobsen, C. Maccani, E. Matheson, D. Mirarchi, A. Perillo Marcone, S. Redaelli, B. Salvant, R. Seidenbinder, S. Solis Paiva, E. Soria, C. Zannini

IJCLab, Orsay, France

A. Fomin, P. Robbe, A. Stocchi

INFN Milano and University of Milano

S. Cesare, S. Coelli, P. Gandini,
D. Marangotto, A. Merli**, N. Neri, E. Spadaro Norella*, G. Tonani, F. Zangari

Warsaw University of Technology, Poland

M. Patecki

IFIC, University of Valencia-CSIC, Spain

S.J. Jaimes Elles, S. Libralon, F. Martinez Vidal,
J. Mazorra de Cos, I. Sanderswood, S. Vico Gil

INFN Ferrara and University of Ferrara

L. Bandiera, V. Guidi, L. Malagutti, A. Mazzolari, R. Negrello, M. Romagnoni, M. Tamisari

INFN Padova and University of Padova

M. Benettoni, G. Simi, A. Triossi, M. Zanetti

INFN Legnaro Labs and University of Padova

D. De Salvador

INFN Pisa and Pisa University

G. Lamanna, J. Pinzino, M. Sozzi, N. Turini

UCAS, China

J. Fu, H. Miao, T. Xing

University of Malta

L. Grech, G. Valentino

Institute of Nuclear Physics - Polish Academy of Sciences

K. Korcyl



Hyperon polarization

- Amplitude for $J/\psi \rightarrow B\bar{B}$, F_A and H_T for P and CP violation

$$\mathcal{M}_{\lambda_1, \lambda_2} = \epsilon_\mu (\lambda_1 - \lambda_2) \bar{u}(\lambda_1, p_1) \left(F_V \gamma^\mu + \frac{i}{2m} \sigma^{\mu\nu} q_\nu H_\sigma + \gamma^\mu \gamma^5 F_A + \sigma^{\mu\nu} \gamma^5 q_\nu H_T \right) v(\lambda_2, p_2)$$

- Transverse polarization if non-zero $\Delta\Phi$

$$F_V = G_1 - 4m^2 \frac{(G_1 - G_2)}{(p_1 - p_2)^2} \quad H_\sigma = 4m^2 \frac{(G_1 - G_2)}{(p_1 - p_2)^2}$$

$$\alpha_{J/\psi} = \frac{M^2 J/\psi |G_1|^2 - 4m^2 |G_2|^2}{M^2 J/\psi |G_1|^2 + 4m^2 |G_2|^2} \quad \frac{G_1}{G_2} = \left| \frac{G_1}{G_2} \right| e^{-i\Delta\Phi}$$

Polarization:

$$P_y(\cos\theta) = \frac{\sqrt{1 - \alpha_\psi^2} \cos\theta \sin\theta}{1 + \alpha_\psi \cos^2\theta} \sin(\Delta\Phi)$$

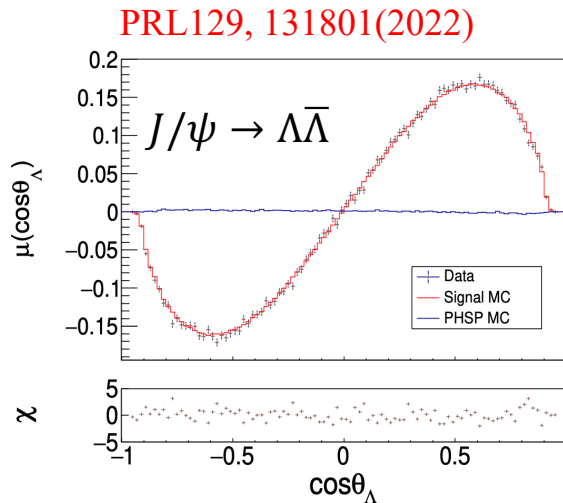
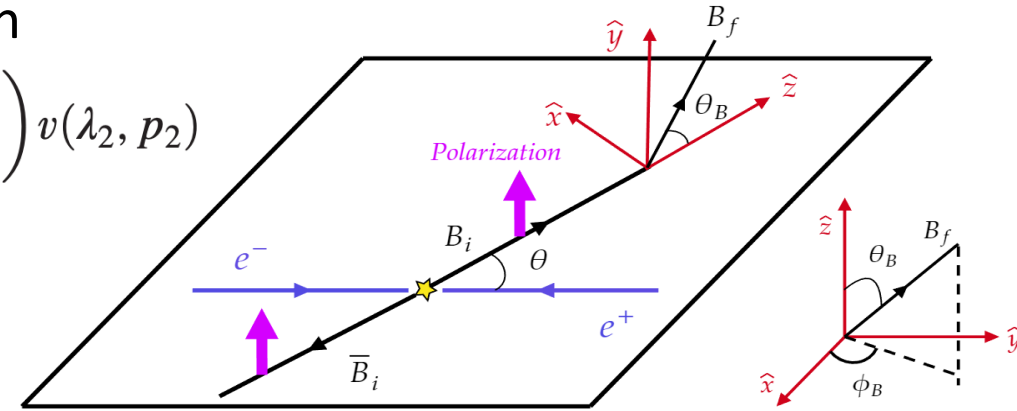

$$\Delta\Phi = (0.7521 \pm 0.0042 \pm 0.0066) \text{ rad}$$

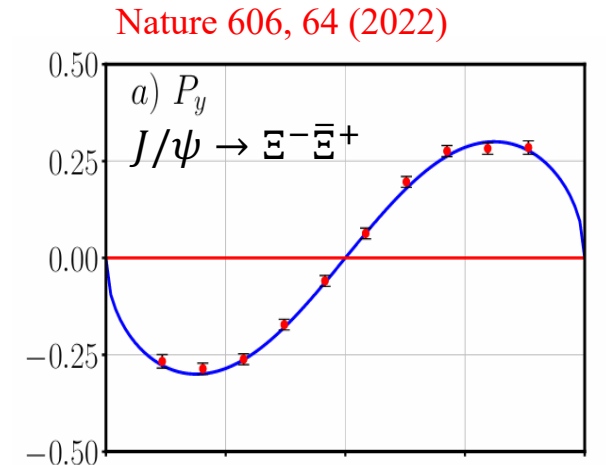

$$\Delta\Phi = (1.213 \pm 0.046 \pm 0.016) \text{ rad}$$

Angular distribution

J. Fu, H.B.Li *et al.* Phys. Rev. D 108, L091301 (2023)

$$\frac{d\sigma}{d\Omega} \propto \sum_{[\lambda]} R(\lambda_1, \lambda_2; \lambda'_1, \lambda'_2)$$

$$D_{\lambda_1, \lambda_3}^{*j=1/2}(\phi_1, \theta_1) D_{\lambda'_1, \lambda'_3}^{j=1/2}(\phi_1, \theta_1) \mathcal{H}_{\lambda_3}^* \mathcal{H}_{\lambda'_3}$$

$$D_{\lambda_2, \lambda_4}^{*j=1/2}(\phi_2, \theta_2) D_{\lambda'_2, \lambda'_4}^{j=1/2}(\phi_2, \theta_2) \bar{\mathcal{H}}_{\lambda_4}^* \bar{\mathcal{H}}_{\lambda'_4}$$

Type I:

$$e^+ e^- \rightarrow J/\psi \rightarrow \Lambda \bar{\Lambda}, \quad \Lambda \rightarrow p \pi^-$$

$$e^+ e^- \rightarrow J/\psi \rightarrow \Sigma^+ \bar{\Sigma}^-, \quad \Sigma^+ \rightarrow p \pi^0$$

$$R(\lambda_1, \lambda_2; \lambda'_1, \lambda'_2) \propto \sum_{m, m'} \rho_{m, m'} d_{m, \lambda_1 - \lambda_2}^{j=1}(\theta) d_{m', \lambda'_1 - \lambda'_2}^{j=1}(\theta)$$

$$\times \mathcal{M}_{\lambda_1, \lambda_2} \mathcal{M}_{\lambda'_1, \lambda'_2}^* \delta_{m, m'},$$

$$\mathcal{M}_{\lambda_1, \lambda_2} = \epsilon_\mu(\lambda_1 - \lambda_2) \bar{u}(\lambda_1, p_1) (F_V \gamma^\mu + \frac{i}{2M_\Lambda} \sigma^{\mu\nu} q_\nu H_\sigma$$

$$+ \gamma^\mu \gamma^5 F_A + \sigma^{\mu\nu} \gamma^5 q_\nu H_T) v(\lambda_2, p_2).$$

Angular distribution

J. Fu, H.B.Li *et al.* Phys. Rev. D 108, L091301 (2023)

$$\frac{d\sigma}{d\Omega} \propto \sum_{[\lambda]} R(\lambda_1, \lambda_2; \lambda'_1, \lambda'_2)$$

$$\begin{aligned} & D_{\lambda_1, \lambda_3}^{*j=1/2}(\phi_1, \theta_1) D_{\lambda'_1, \lambda'_3}^{j=1/2}(\phi_1, \theta_1) \mathcal{H}_{\lambda_3}^* \mathcal{H}_{\lambda'_3} \\ & D_{\lambda_2, \lambda_4}^{*j=1/2}(\phi_2, \theta_2) D_{\lambda'_2, \lambda'_4}^{j=1/2}(\phi_2, \theta_2) \bar{\mathcal{H}}_{\lambda_4}^* \bar{\mathcal{H}}_{\lambda'_4} \\ & D_{\lambda_3, \lambda_5}^{*j=1/2}(\phi_3, \theta_3) D_{\lambda'_3, \lambda'_5}^{j=1/2}(\phi_3, \theta_3) \mathcal{F}_{\lambda_5}^* \mathcal{F}_{\lambda_5} \\ & D_{\lambda_4, \lambda_6}^{*j=1/2}(\phi_4, \theta_4) D_{\lambda'_4, \lambda'_6}^{j=1/2}(\phi_4, \theta_4) \bar{\mathcal{F}}_{\lambda_6}^* \bar{\mathcal{F}}_{\lambda_6} \end{aligned}$$

$$\begin{aligned} R(\lambda_1, \lambda_2; \lambda'_1, \lambda'_2) & \propto \sum_{m, m'} \rho_{m, m'} d_{m, \lambda_1 - \lambda_2}^{j=1}(\theta) d_{m', \lambda'_1 - \lambda'_2}^{j=1}(\theta) \\ & \quad \times \mathcal{M}_{\lambda_1, \lambda_2} \mathcal{M}_{\lambda'_1, \lambda'_2}^* \delta_{m, m'}, \end{aligned}$$

$$\begin{aligned} \mathcal{M}_{\lambda_1, \lambda_2} & = \epsilon_\mu(\lambda_1 - \lambda_2) \bar{u}(\lambda_1, p_1) (F_V \gamma^\mu + \frac{i}{2M_\Lambda} \sigma^{\mu\nu} q_\nu H_\sigma \\ & \quad + \gamma^\mu \gamma^5 F_A + \sigma^{\mu\nu} \gamma^5 q_\nu H_T) v(\lambda_2, p_2). \end{aligned}$$

Type II:

$$\begin{aligned} e^+ e^- \rightarrow J/\psi \rightarrow \Xi^- \bar{\Xi}^+, \quad \Xi^- \rightarrow \Lambda \pi^- \\ e^+ e^- \rightarrow J/\psi \rightarrow \Xi^0 \bar{\Xi}^0, \quad \Xi^0 \rightarrow \Lambda \pi^0 \end{aligned}$$

Angular distribution

J. Fu, H.B.Li *et al.* Phys. Rev. D 108, L091301 (2023)

$$\frac{d\sigma}{d\Omega} \propto \sum_{[\lambda]} R(\lambda_1, \lambda_2; \lambda'_1, \lambda'_2)$$

$$\begin{aligned} & D_{\lambda_1, \lambda_3}^{*j=1/2}(\phi_1, \theta_1) D_{\lambda'_1, \lambda'_3}^{j=1/2}(\phi_1, \theta_1) \mathcal{H}_{\lambda_3}^* \mathcal{H}_{\lambda'_3} \\ & D_{\lambda_2, \lambda_4}^{*j=1/2}(\phi_2, \theta_2) D_{\lambda'_2, \lambda'_4}^{j=1/2}(\phi_2, \theta_2) \bar{\mathcal{H}}_{\lambda_4}^* \bar{\mathcal{H}}_{\lambda'_4} \\ & D_{\lambda_3, \lambda_5}^{*j=1/2}(\phi_3, \theta_3) D_{\lambda'_3, \lambda'_5}^{j=1/2}(\phi_3, \theta_3) \mathcal{F}_{\lambda_5}^* \mathcal{F}_{\lambda'_5} \\ & D_{\lambda_4, \lambda_6}^{*j=1/2}(\phi_4, \theta_4) D_{\lambda'_4, \lambda'_6}^{j=1/2}(\phi_4, \theta_4) \bar{\mathcal{F}}_{\lambda_6}^* \bar{\mathcal{F}}_{\lambda'_6} \end{aligned}$$

$$R(\lambda_1, \lambda_2; \lambda'_1, \lambda'_2) \propto \sum_{m, m'} \rho_{m, m'} d_{m, \lambda_1 - \lambda_2}^{j=1}(\theta) d_{m', \lambda'_1 - \lambda'_2}^{j=1}(\theta)$$

$$\times \mathcal{M}_{\lambda_1, \lambda_2} \mathcal{M}_{\lambda'_1, \lambda'_2}^* \delta_{m, m'},$$

$$\begin{aligned} \mathcal{M}_{\lambda_1, \lambda_2} = & \epsilon_\mu (\lambda_1 - \lambda_2) \bar{u}(\lambda_1, p_1) (F_V \gamma^\mu + \frac{i}{2M_\Lambda} \sigma^{\mu\nu} q_\nu H_\sigma \\ & + \gamma^\mu \gamma^5 F_A + \sigma^{\mu\nu} \gamma^5 q_\nu H_T) v(\lambda_2, p_2). \end{aligned}$$

□ Lee-Yang parameters in hyperon weak decays defined by helicity amplitude H and F

$$\alpha = (|H_{1/2}|^2 - |H_{-1/2}|^2) / (|H_{1/2}|^2 + |H_{-1/2}|^2)$$

$$\beta = 2\text{Im}(H_{1/2} H_{-1/2}^*) / (|H_{1/2}|^2 + |H_{-1/2}|^2)$$

$$\gamma = 2\text{Re}(H_{1/2} H_{-1/2}^*) / (|H_{1/2}|^2 + |H_{-1/2}|^2)$$

□ CP-violating observables

$$A_{CP} = (\alpha + \bar{\alpha}) / (\alpha - \bar{\alpha})$$

$$B_{CP} = (\beta + \bar{\beta}) / (\alpha - \bar{\alpha})$$

F_A and H_T not necessary

Several measurements from BESIII with world-leading precision

Angular distribution

J. Fu, H.B.Li *et al.* Phys. Rev. D 108, L091301 (2023)

$$\frac{d\sigma}{d\Omega} \propto \sum_{[\lambda]} R(\lambda_1, \lambda_2; \lambda'_1, \lambda'_2)$$

$$D_{\lambda_1, \lambda_3}^{*j=1/2}(\phi_1, \theta_1) D_{\lambda'_1, \lambda'_3}^{j=1/2}(\phi_1, \theta_1) \mathcal{H}_{\lambda_3}^* \mathcal{H}_{\lambda'_3}$$

$$D_{\lambda_2, \lambda_4}^{*j=1/2}(\phi_2, \theta_2) D_{\lambda'_2, \lambda'_4}^{j=1/2}(\phi_2, \theta_2) \bar{\mathcal{H}}_{\lambda_4}^* \bar{\mathcal{H}}_{\lambda'_4}$$

$$D_{\lambda_3, \lambda_5}^{*j=1/2}(\phi_3, \theta_3) D_{\lambda'_3, \lambda'_5}^{j=1/2}(\phi_3, \theta_3) \mathcal{F}_{\lambda_5}^* \mathcal{F}_{\lambda_5}$$

$$D_{\lambda_4, \lambda_6}^{*j=1/2}(\phi_4, \theta_4) D_{\lambda'_4, \lambda'_6}^{j=1/2}(\phi_4, \theta_4) \bar{\mathcal{F}}_{\lambda_6}^* \bar{\mathcal{F}}_{\lambda_6}$$

$$R(\lambda_1, \lambda_2; \lambda'_1, \lambda'_2) \propto \sum_{m, m'} \rho_{m, m'} d_{m, \lambda_1 - \lambda_2}^{j=1}(\theta) d_{m', \lambda'_1 - \lambda'_2}^{j=1}(\theta)$$

$$\times \mathcal{M}_{\lambda_1, \lambda_2} \mathcal{M}_{\lambda'_1, \lambda'_2}^* \delta_{m, m'},$$

$$\mathcal{M}_{\lambda_1, \lambda_2} = \epsilon_\mu (\lambda_1 - \lambda_2) \bar{u}(\lambda_1, p_1) (F_V \gamma^\mu + \frac{i}{2M_\Lambda} \sigma^{\mu\nu} q_\nu H_\sigma$$

$$+ \gamma^\mu \gamma^5 F_A + \sigma^{\mu\nu} \gamma^5 q_\nu \underline{H_T}) v(\lambda_2, p_2).$$

Longitudinal polarization of J/ψ , P_L relative difference between ρ_{++} and ρ_{--}

$$P_L = \mathcal{A}_{LR}^0 = \frac{\sigma_R - \sigma_L}{\sigma_R + \sigma_L} = \frac{-\sin^2 \theta_W^{\text{eff}} + 3/8}{2 \sin^2 \theta_W^{\text{eff}} \cos^2 \theta_W^{\text{eff}}} \frac{M_{J/\psi}^2}{m_Z^2}$$