



BESIII

Study of Excited Baryons and Their Decay Properties at BESIII

郑文静

中国科学院高能物理研究所

2026 轻强子专题研讨会 | 2026.05.14-18, 商丘

Outline

- **Introduction**
- **Experiment at BESIII**
- **Key Results**
- **Summary and Outlook**

Introduction: Baryon Family

■ With SU(3) symmetry and the standard model, all baryons in octet and dectet are established well.

■ For the higher excited states, we have not a good understand.

- ◆ Inaccurate masses, widths
- ◆ Unknown J^P
- ◆ Missing resonances
- ◆ Multiquark states
- ◆ ...

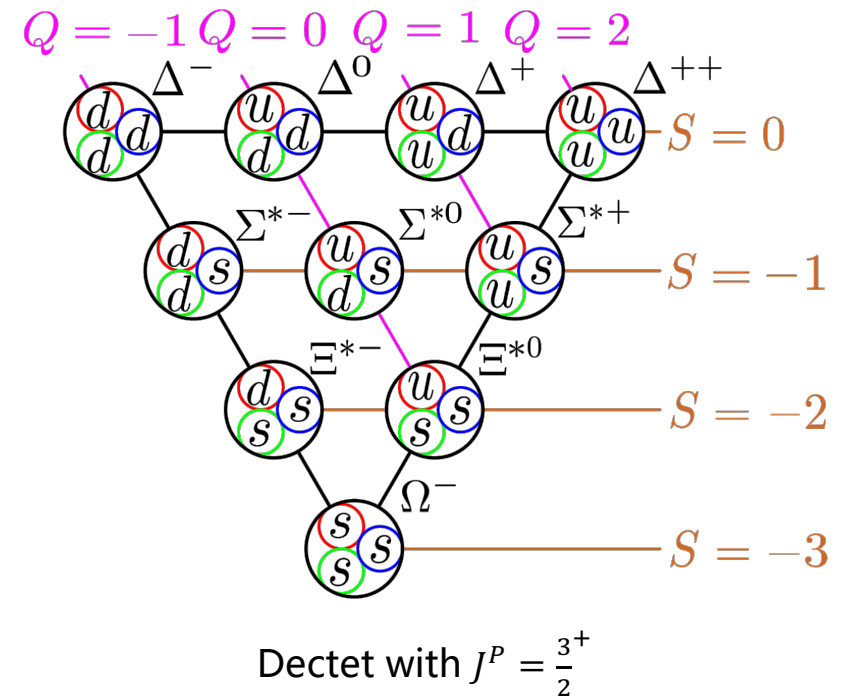
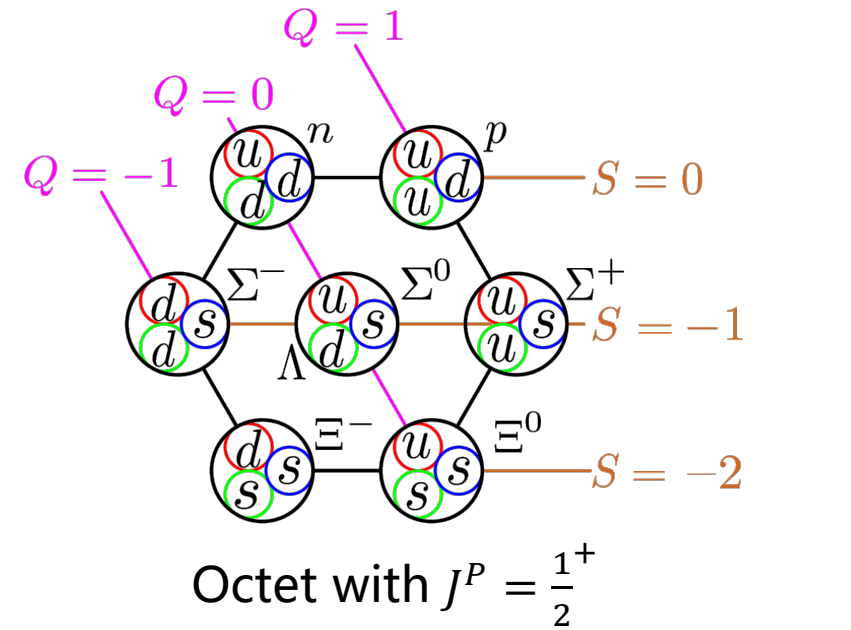

Introduction: N^* and Δ^* status ($|S| = 0$)

- The most thoroughly studied and data-rich area of excited baryons
 - Broad mass and spin coverage.
 - The precision of the mass, width, and branching fraction remains insufficient.

Particle	J^P	Status as seen in										
		overall	$N\gamma$	$N\pi$	$\Delta\pi$	$N\sigma$	$N\eta$	ΛK	ΣK	$N\rho$	$N\omega$	$N\eta'$
N	$1/2^+$	****										
$N(1440)$	$1/2^+$	****	****	****	****	***						
$N(1520)$	$3/2^-$	****	****	****	****	**	****					
$N(1535)$	$1/2^-$	****	****	****	***	*	****					
$N(1650)$	$1/2^-$	****	****	****	***	*	****	*				
$N(1675)$	$5/2^-$	****	****	****	****	***	*	*	*			
$N(1680)$	$5/2^+$	****	****	****	****	***	*	*	*			
$N(1700)$	$3/2^-$	***	**	***	***	*	*			*		
$N(1710)$	$1/2^+$	****	****	****	*		***	**	*	*	*	
$N(1720)$	$3/2^+$	****	****	****	***	*	*	****	*	*	*	
$N(1860)$	$5/2^+$	**	*	**	*	*	*					
$N(1875)$	$3/2^-$	***	**	**	*	*	*	*	*	*	*	
$N(1880)$	$1/2^+$	***	**	*	**	*	*	**	**		**	
$N(1895)$	$1/2^-$	****	****	*	*	*	****	**	**	*	*	****
$N(1900)$	$3/2^+$	****	****	**	**	*	*	**	**	*	**	
$N(1990)$	$7/2^+$	**	**	**		*	*	*				
$N(2000)$	$5/2^+$	**	**	*	**	*	*			*		
$N(2040)$	$3/2^+$	*		*								
$N(2060)$	$5/2^-$	***	***	**	*	*	*	*	*	*	*	
$N(2100)$	$1/2^+$	***	**	***	**	**	*	*	*	*	**	
$N(2120)$	$3/2^-$	***	**	**	**	**		**	*	*	*	*
$N(2190)$	$7/2^-$	****	****	****	****	**	*	**	*	*	*	
$N(2220)$	$9/2^+$	****	**	****		*	*	*				
$N(2250)$	$9/2^-$	****	**	****		*	*	*				
$N(2300)$	$1/2^+$	**		**								
$N(2570)$	$5/2^-$	**		**								
$N(2600)$	$11/2^-$	***		***								
$N(2700)$	$13/2^+$	**		**								

Particle	J^P	Status as seen in						
		overall	$N\gamma$	$N\pi$	$\Delta\pi$	ΣK	$N\rho$	$\Delta\eta$
$\Delta(1232)$	$3/2^+$	****	****	****				
$\Delta(1600)$	$3/2^+$	****	****	***	****			
$\Delta(1620)$	$1/2^-$	****	****	****	****			
$\Delta(1700)$	$3/2^-$	****	****	****	****	*	*	
$\Delta(1750)$	$1/2^+$	*	*	*		*		
$\Delta(1900)$	$1/2^-$	***	***	***	*	**	*	
$\Delta(1905)$	$5/2^+$	****	****	****	**	*	*	**
$\Delta(1910)$	$1/2^+$	****	***	****	**	**		*
$\Delta(1920)$	$3/2^+$	***	***	***	***	**		**
$\Delta(1930)$	$5/2^-$	***	*	***	*	*		
$\Delta(1940)$	$3/2^-$	**	*	**	*			*
$\Delta(1950)$	$7/2^+$	****	****	****	**	***		
$\Delta(2000)$	$5/2^+$	**	*	**	*			*
$\Delta(2150)$	$1/2^-$	*		*				
$\Delta(2200)$	$7/2^-$	***	***	**	***	**		
$\Delta(2300)$	$9/2^+$	**		**				
$\Delta(2350)$	$5/2^-$	*		*				
$\Delta(2390)$	$7/2^+$	*		*				
$\Delta(2400)$	$9/2^-$	**	**	**				
$\Delta(2420)$	$11/2^+$	****	*	****				
$\Delta(2750)$	$13/2^-$	**		**				
$\Delta(2950)$	$15/2^+$	**		**				

Introduction: Λ^* and Σ^* status ($|S| = 1$)

- Starve for data
- The information on decay channels is incomplete
- The spin-parity quantum numbers of many states have not been determined

Particle	J^P	Overall status	Status as seen in —		
			$N\bar{K}$	$\Sigma\pi$	Other channels
$\Lambda(1116)$	$1/2^+$	****			$N\pi$ (weak decay)
$\Lambda(1380)$	$1/2^-$	**	**	**	
$\Lambda(1405)$	$1/2^-$	****	****	****	
$\Lambda(1520)$	$3/2^-$	****	****	****	$\Lambda\pi\pi, \Lambda\gamma, \Sigma\pi\pi$
$\Lambda(1600)$	$1/2^+$	****	***	****	$\Lambda\pi\pi, \Sigma(1385)\pi$
$\Lambda(1670)$	$1/2^-$	****	****	****	$\Lambda\eta$
$\Lambda(1690)$	$3/2^-$	****	****	***	$\Lambda\pi\pi, \Sigma(1385)\pi$
$\Lambda(1710)$	$1/2^+$	*	*	*	
$\Lambda(1800)$	$1/2^-$	***	***	**	$\Lambda\pi\pi, N\bar{K}^*$
$\Lambda(1810)$	$1/2^+$	***	**	**	$N\bar{K}^*$
$\Lambda(1820)$	$5/2^+$	****	****	****	$\Sigma(1385)\pi$
$\Lambda(1830)$	$5/2^-$	****	****	****	$\Sigma(1385)\pi$
$\Lambda(1890)$	$3/2^+$	****	****	**	$\Sigma(1385)\pi, N\bar{K}^*$
$\Lambda(2000)$	$1/2^-$	*	*	*	
$\Lambda(2050)$	$3/2^-$	*	*	*	
$\Lambda(2070)$	$3/2^+$	*	*	*	
$\Lambda(2080)$	$5/2^-$	*	*	*	
$\Lambda(2085)$	$7/2^+$	**	**	*	
$\Lambda(2100)$	$7/2^-$	****	****	**	$N\bar{K}^*$
$\Lambda(2110)$	$5/2^+$	***	**	**	$N\bar{K}^*$
$\Lambda(2325)$	$3/2^-$	*	*		
$\Lambda(2350)$	$9/2^+$	***	***	*	
$\Lambda(2585)$		*	*		

Particle	J^P	Overall status	Status as seen in —			Other channels
			$N\bar{K}$	$\Lambda\pi$	$\Sigma\pi$	
$\Sigma(1193)$	$1/2^+$	****				$N\pi$ (weak decay)
$\Sigma(1385)$	$3/2^+$	****		****	****	$\Lambda\gamma$
$\Sigma(1580)$	$3/2^-$	*	*	*	*	
$\Sigma(1620)$	$1/2^-$	*	*	*	*	
$\Sigma(1660)$	$1/2^+$	***	***	***	***	
$\Sigma(1670)$	$3/2^-$	****	****	****	****	
$\Sigma(1750)$	$1/2^-$	***	***	**	***	$\Sigma\eta$
$\Sigma(1775)$	$5/2^-$	****	****	****	**	
$\Sigma(1780)$	$3/2^+$	*	*	*	*	
$\Sigma(1880)$	$1/2^+$	**	**	*		
$\Sigma(1900)$	$1/2^-$	**	**	*	**	
$\Sigma(1910)$	$3/2^-$	***	*	*	**	
$\Sigma(1915)$	$5/2^+$	****	***	***	***	
$\Sigma(1940)$	$3/2^+$	*	*		*	
$\Sigma(2010)$	$3/2^-$	*	*	*		
$\Sigma(2030)$	$7/2^+$	****	****	****	**	$\Delta(1232)\bar{K}, N\bar{K}^*, \Sigma(1385)\pi$
$\Sigma(2070)$	$5/2^+$	*	*		*	
$\Sigma(2080)$	$3/2^+$	*		*		
$\Sigma(2100)$	$7/2^-$	*	*	*	*	
$\Sigma(2110)$	$1/2^-$	*	*	*	*	
$\Sigma(2230)$	$3/2^+$	*	*	*	*	
$\Sigma(2250)$		**	**	*	*	
$\Sigma(2455)$		*	*			
$\Sigma(2620)$		*	*			
$\Sigma(3000)$		*	*	*		
$\Lambda(3170)$		*				

Introduction: Ξ^* and Ω^* status ($|S| \geq 2$)

- Even less is known about Ξ^* and Ω^* .
- $\Omega(2012)$
 - ◆ In 2018, Belle II collaboration reported a new $\Omega(2012)$ state via ΞK process
 - ◆ In 2025, ALICE and BESIII Collaborations confirmed the existence of the $\Omega(2012)$
 - ◆ Unmeasured quantum number

Particle	J^P	Overall status	Status as seen in —				
			$\Xi\pi$	ΛK	ΣK	$\Xi(1530)\pi$	Other channels
$\Xi(1318)$	1/2+	****					Decays weakly
$\Xi(1530)$	3/2+	****	****				
$\Xi(1620)$		**	**				
$\Xi(1690)$		***	**	***	**		
$\Xi(1820)$	3/2-	***	**	***	**	**	
$\Xi(1950)$		***	**	**		*	
$\Xi(2030)$		***		**	***		
$\Xi(2120)$		*		*			
$\Xi(2250)$		**					3-body decays
$\Xi(2370)$		**					3-body decays
$\Xi(2500)$		*		*	*		3-body decays

Ω^-	3/2+	****
$\Omega(2012)^-$?-	***
$\Omega(2250)^-$		***
$\Omega(2380)^-$		**
$\Omega(2470)^-$		**

Excited baryons, especially hyperons, urgently require new and high-precision experimental input.

Experiment at BESIII: Advantage on Baryon Spectroscopy

- Symmetric collider for e^+e^- annihilating
- Wider energy range
- 10 billion J/ψ
- 2.7 billion $\psi(2S)$
- Low backgrounds and high signals
- Two-body or three-body baryonic processes
- Method:
 - ◆ PWA
 - ◆ Electromagnetic Radiative Decays

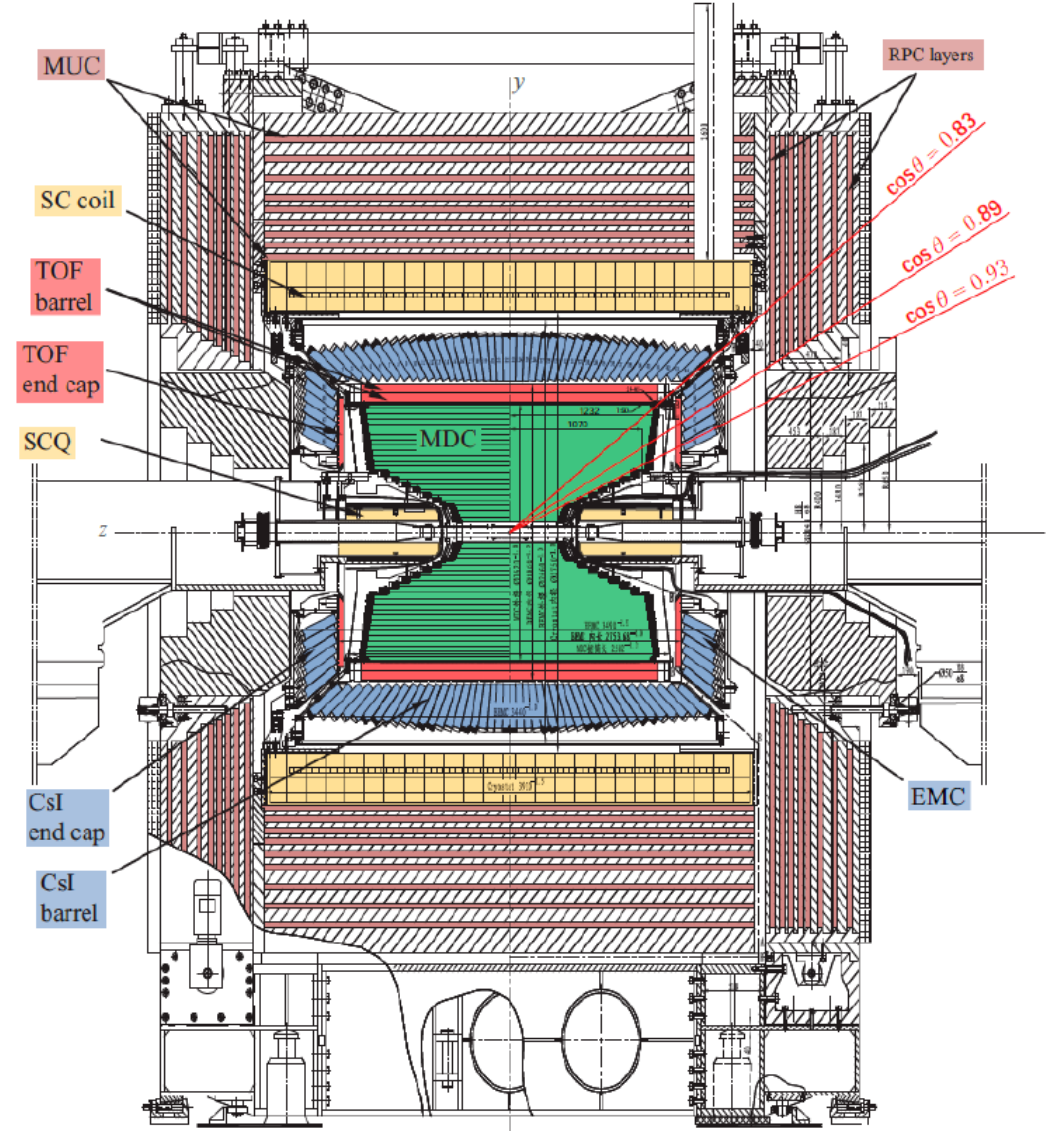

Key Results: PWA — $\psi(2S) \rightarrow \Lambda \bar{\Sigma}^0 \pi^0$

- Flatté-like and chiral dynamics model for $\Lambda(1405)$ dipole structure
 - ◆ Due to the limited statistics, two model are not distinguishable
- Strong existence of $\Lambda(2325): J^P = \frac{3^-}{2}$

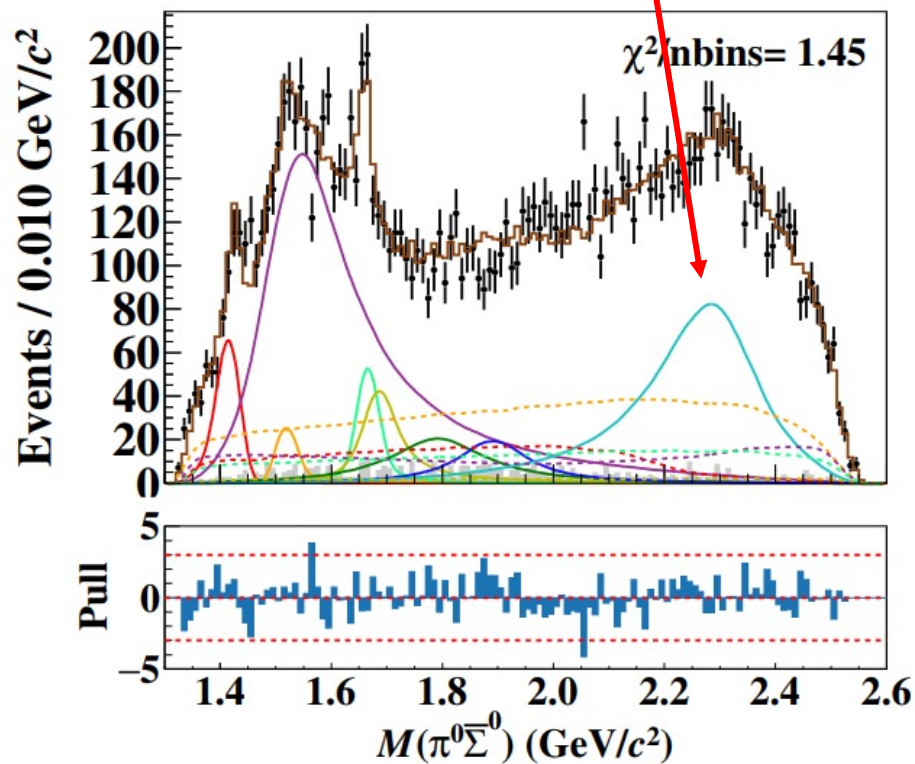

Resonance	Mass (MeV/c ²)	Width (MeV)	\mathcal{B} ($\times 10^{-5}$)
$\Lambda(1405)$	$0.44 \pm 0.05 \pm 0.12$
$\Lambda(1520)$	$1519.9 \pm 1.6 \pm 4.8$	$20.6 \pm 1.9 \pm 0.6$	$0.19 \pm 0.05 \pm 0.05$
$\Lambda(1600)$	$1570.5 \pm 4.6 \pm 12.1$	$228.1 \pm 11.9 \pm 34.8$	$4.49 \pm 0.25 \pm 1.23$
$\Lambda(1670)$	$1667.5 \pm 2.3 \pm 3.6$	$30.2 \pm 4.2 \pm 8.7$	$0.33 \pm 0.07 \pm 0.09$
$\Lambda(1690)$	$1691.1 \pm 4.4 \pm 15.7$	$72.3 \pm 4.7 \pm 18.3$	$0.55 \pm 0.11 \pm 0.10$
$\Lambda(1800)$	$1800.9 \pm 13.3 \pm 12.6$	$208.8 \pm 14.5 \pm 36.7$	$0.60 \pm 0.15 \pm 0.18$
$\Lambda(1890)$	$1897.2 \pm 9.6 \pm 6.2$	$149.2 \pm 13.5 \pm 4.1$	$0.47 \pm 0.10 \pm 0.09$
$\Lambda(2325)$	$2306.5 \pm 6.3 \pm 17.1$	$227.1 \pm 12.2 \pm 47.8$	$2.93 \pm 0.20 \pm 0.26$
$\Sigma(1385)$	$1388.2 \pm 1.9 \pm 3.3$	$60.5 \pm 3.6 \pm 6.3$	$1.30 \pm 0.11 \pm 0.19$
$\Sigma(1660)$	$1643.2 \pm 4.5 \pm 7.6$	$221.3 \pm 13.1 \pm 41.1$	$3.53 \pm 0.29 \pm 0.63$
$\Sigma(1670)$	$1679.7 \pm 3.4 \pm 4.3$	$87.0 \pm 6.4 \pm 8.9$	$1.60 \pm 0.25 \pm 0.38$
$\Sigma(1750)$	$1714.9 \pm 4.2 \pm 7.3$	$97.2 \pm 9.8 \pm 9.7$	$1.39 \pm 0.23 \pm 0.32$
$\Sigma(1910)$	$1912.1 \pm 10.6 \pm 33.6$	$225.1 \pm 24.5 \pm 46.0$	$0.23 \pm 0.10 \pm 0.06$

Key Results: PWA — $\psi(2S) \rightarrow \bar{p}K^+\Sigma^0$

- New excited state, $\Sigma(2330)$, in the $M_{\bar{p}K^+}$ distribution with 11.9σ .
- Favors $J^P = \frac{3}{2}^-$
- Compatible with the predicted $1F(3/2^-)$ state within $5 \text{ GeV}/c^2$

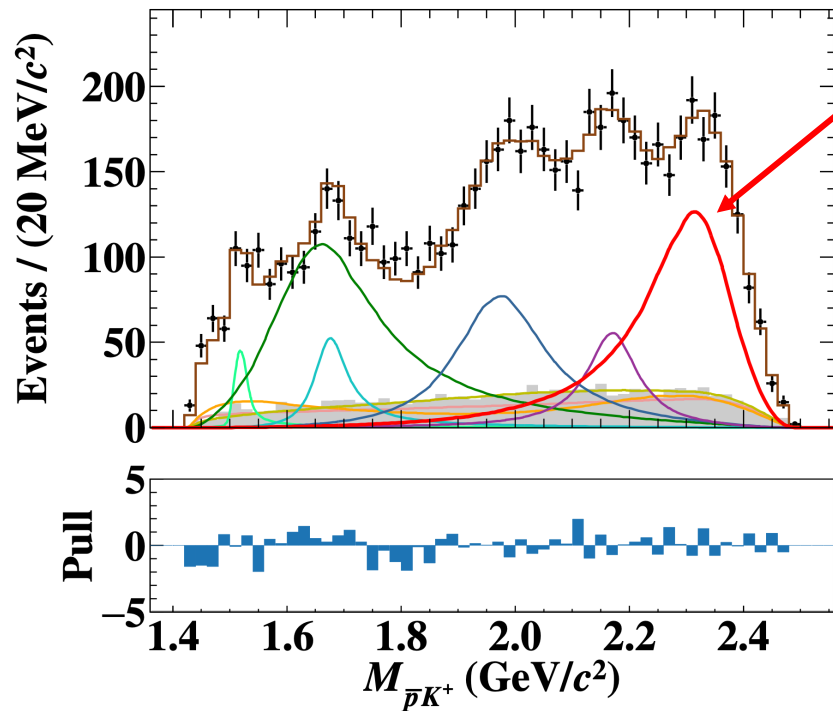

Resonance	Mass (MeV/c ²)	Width (MeV)	\mathcal{B} ($\times 10^{-6}$)
$N(2300)$	$2285.3 \pm 13.8 \pm 26.1$	$335.9 \pm 14.6 \pm 21.6$	$1.95 \pm 0.53 \pm 0.58$
$N(2570)$	$2577.9 \pm 14.8 \pm 33.2$	$255.1 \pm 14.6 \pm 19.7$	$2.28 \pm 0.53 \pm 0.67$
$\Lambda(1520)$	—	—	$0.49 \pm 0.10 \pm 0.14$
$\Sigma(1660)$	$1680.5 \pm 13.8 \pm 21.3$	$247.7 \pm 15.8 \pm 18.8$	$5.84 \pm 0.69 \pm 1.55$
$\Sigma(1670)$	$1680.5 \pm 4.1 \pm 11.0$	$73.4 \pm 9.1 \pm 7.1$	$1.22 \pm 0.38 \pm 0.28$
$\Sigma(2010)$	$1980.1 \pm 10.0 \pm 18.1$	$192.5 \pm 13.3 \pm 13.3$	$3.11 \pm 0.50 \pm 0.92$
$\Sigma(2110)$	$2172.4 \pm 6.3 \pm 10.9$	$107.2 \pm 9.3 \pm 10.2$	$1.17 \pm 0.23 \pm 0.38$
$\Sigma(2330)$	$2334.7 \pm 7.9 \pm 16.0$	$206.3 \pm 9.5 \pm 18.4$	$4.47 \pm 0.58 \pm 1.52$

Key Results: Radiative decays — $\Lambda(1520/1690) \rightarrow \gamma\Lambda/\gamma\Sigma^0$

Phys. Rev. D 73, 114001 (2006)

■ Theoretical predictions:

- ◆ Differ significantly
- ◆ Assuming $\Lambda(1520)$ to be a SU(3) singlet:

$$\mathcal{R} \equiv \frac{B(\Lambda(1520) \rightarrow \gamma\Lambda)}{B(\Lambda(1520) \rightarrow \gamma\Sigma^0)} \approx 0.3$$

■ Experimental measurements:

- ✓ $\Lambda(1520) \rightarrow \gamma\Lambda$
- ? $\Lambda(1520) \rightarrow \gamma\Sigma^0$

$B_i \rightarrow B_f + \gamma$	$\Lambda(1520) \rightarrow \gamma\Lambda$	$\Lambda(1520) \rightarrow \gamma\Sigma^0$
χQM [3]	134	92
$NRQM$	156 [6], 96 [7]	55 [6], 74 [7]
$RCQM$ [8]	215	293
<i>MIT Bag</i> [6]	46	17
<i>Chiral Bag</i> [9, 10]	32	51
<i>Algebraic model</i> [11]	85.1	180.4
CLAS [5]	$167 \pm 43^{+26}_{-12}$	

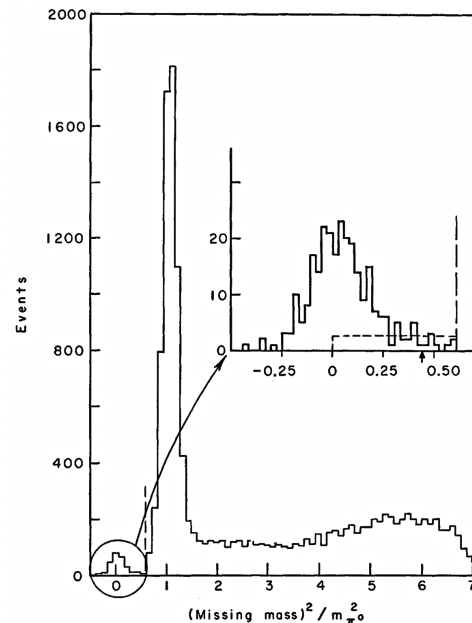

Phys. Rev. Lett. 21, 1715 (1968)

Phys. Rev. C 71, 054609 (2005)

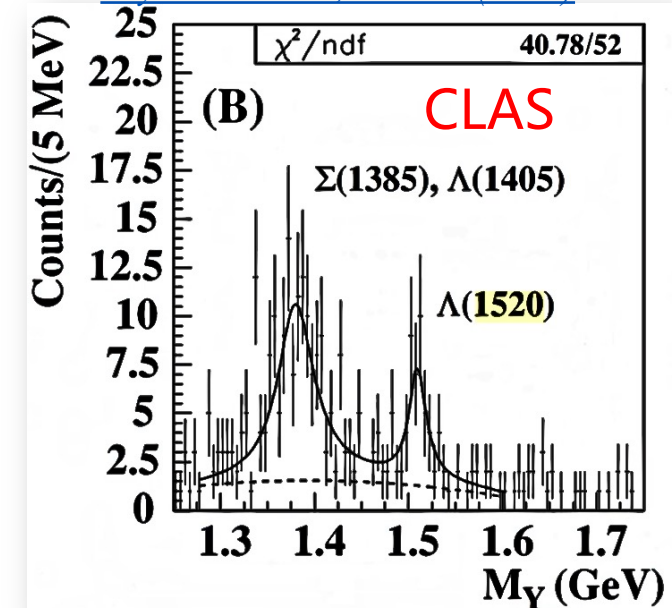

Key Results: Radiative decays — $\Lambda(1520/1690) \rightarrow \gamma\Lambda/\gamma\Sigma^0$

[Phys. Rev. Lett. 136, 141801 \(2026\)](#)

■ First observation of $\Lambda(1520) \rightarrow \gamma\Sigma^0$

- ◆ $\mathcal{R} \equiv \frac{\mathcal{B}(\Lambda(1520) \rightarrow \gamma\Lambda)}{\mathcal{B}(\Lambda(1520) \rightarrow \gamma\Sigma^0)} = 3.19 \pm 0.34(\text{stat.}) \pm 0.19(\text{syst.}) \Rightarrow$ disagree with SU(3)
- ◆ $\Gamma(\Lambda(1520) \rightarrow \gamma\Sigma^0) = (46.8 \pm 6.6(\text{stat.}) \pm 9.3(\text{syst.})) \text{ keV} \Rightarrow$ Compatible with NRQM

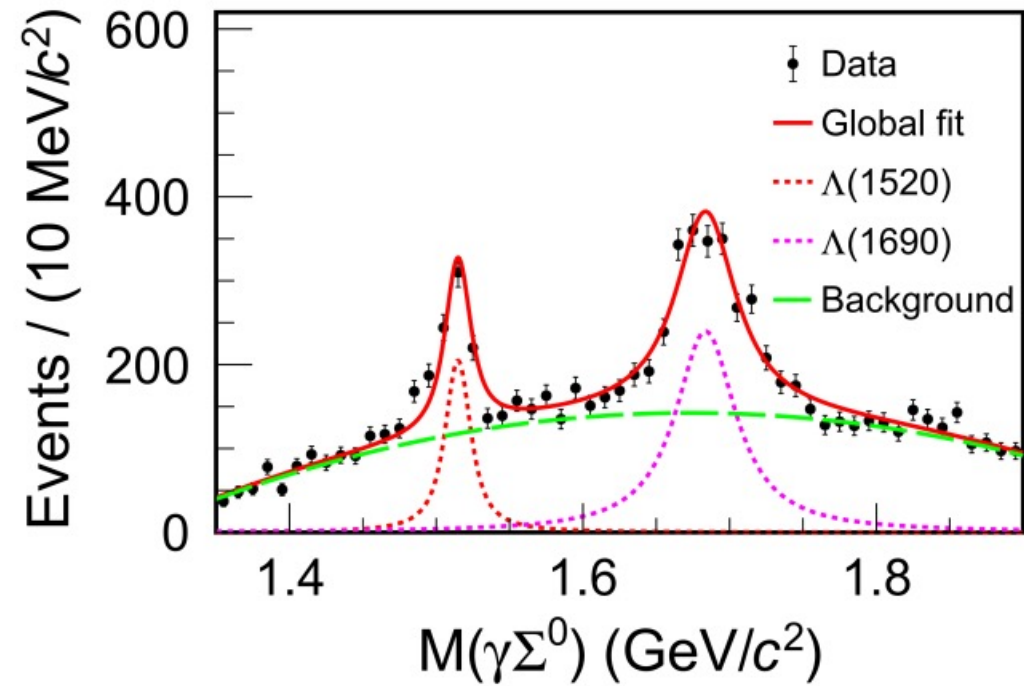
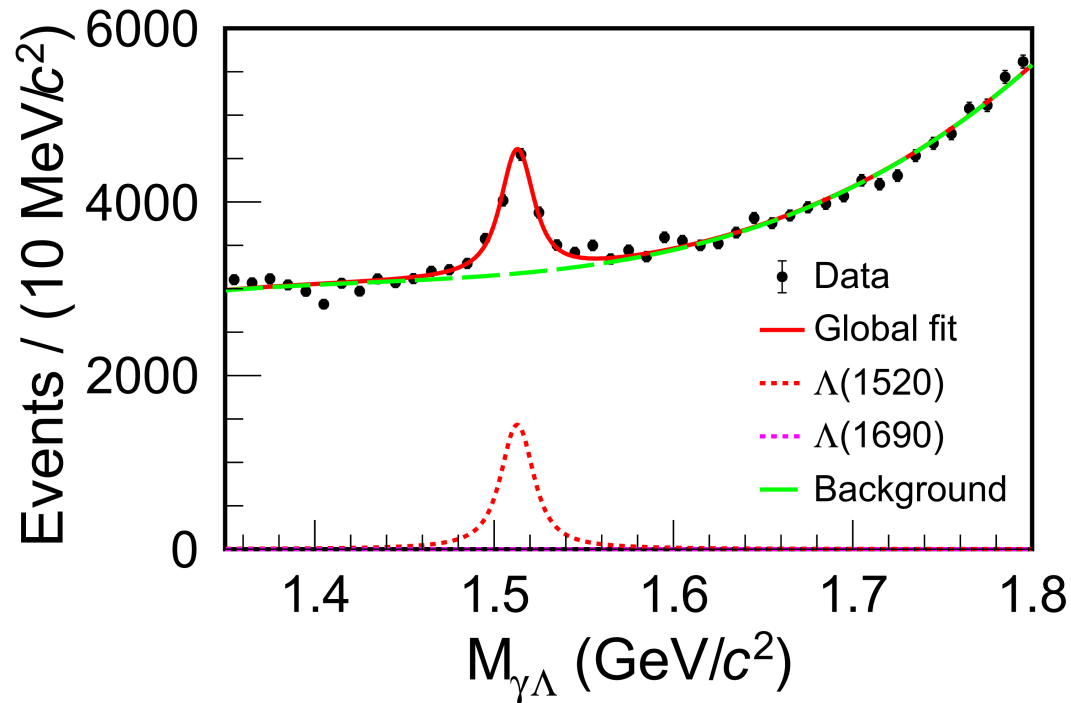

Key Results: Radiative decays — $\Lambda(1520/1690) \rightarrow \gamma\Lambda/\gamma\Sigma^0$

- **New theoretical calculation of $\Lambda(1520) \rightarrow \gamma\Lambda/\gamma\Sigma^0$:** chiral unitary coupled-channel
 - ◆ Only comparable with the result of the $\Gamma(\Lambda(1520) \rightarrow \gamma\Sigma^0)$
 - ◆ Much smaller than the CLAS experimental value

$B_i \rightarrow B_f + \gamma$	$\Lambda(1520) \rightarrow \gamma\Lambda$	$\Lambda(1520) \rightarrow \gamma\Sigma^0$
χQM [3]	134	92
$NRQM$	156 [6], 96 [7]	55 [6], 74 [7]
$RCQM$ [8]	215	293
<i>MIT Bag</i> [6]	46	17
<i>Chiral Bag</i> [9, 10]	32	51
<i>Algebraic model</i> [11]	85.1	180.4
CLAS [5]	$167 \pm 43^{+26}_{-12}$	

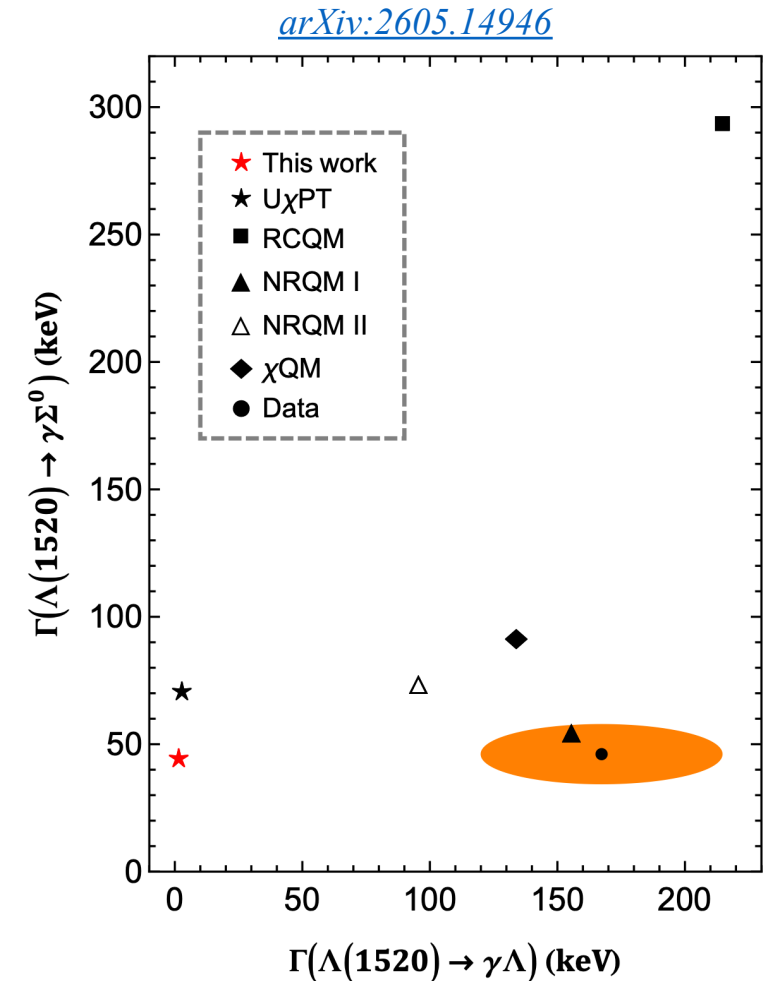

Key Results: Radiative decays — $\Lambda(1520/1690) \rightarrow \gamma\Lambda/\gamma\Sigma^0$

[Phys. Rev. Lett. 136, 141801 \(2026\)](#)

■ First observation of $\Lambda(1690) \rightarrow \gamma\Sigma^0$:

◆ $\mathcal{B}(J/\psi \rightarrow \bar{\Lambda}\Lambda(1690)) \times \mathcal{B}(\Lambda(1690) \rightarrow \gamma\Sigma^0) = (6.05 \pm 0.42(\text{stat.}) \pm 0.39(\text{syst.})) \times 10^{-6}$

■ No signal of $\Lambda(1690) \rightarrow \gamma\Lambda$

◆ $\mathcal{B}(J/\psi \rightarrow \bar{\Lambda}\Lambda(1690)) \times \mathcal{B}(\Lambda(1690) \rightarrow \gamma\Lambda) < 5.08 \times 10^{-7}$ (90% C.L.)

◆ $\mathcal{R} \equiv \frac{\mathcal{B}(\Lambda(1690) \rightarrow \gamma\Lambda)}{\mathcal{B}(\Lambda(1690) \rightarrow \gamma\Sigma^0)} < 0.08$ (90% C.L.)

Mass: $[1683.9 \pm 1.3(\text{stat.}) \pm 0.6(\text{syst.})] \text{MeV}/c^2$
 Width: $[48.8 \pm 4.0(\text{stat.}) \pm 1.6(\text{syst.})] \text{MeV}$

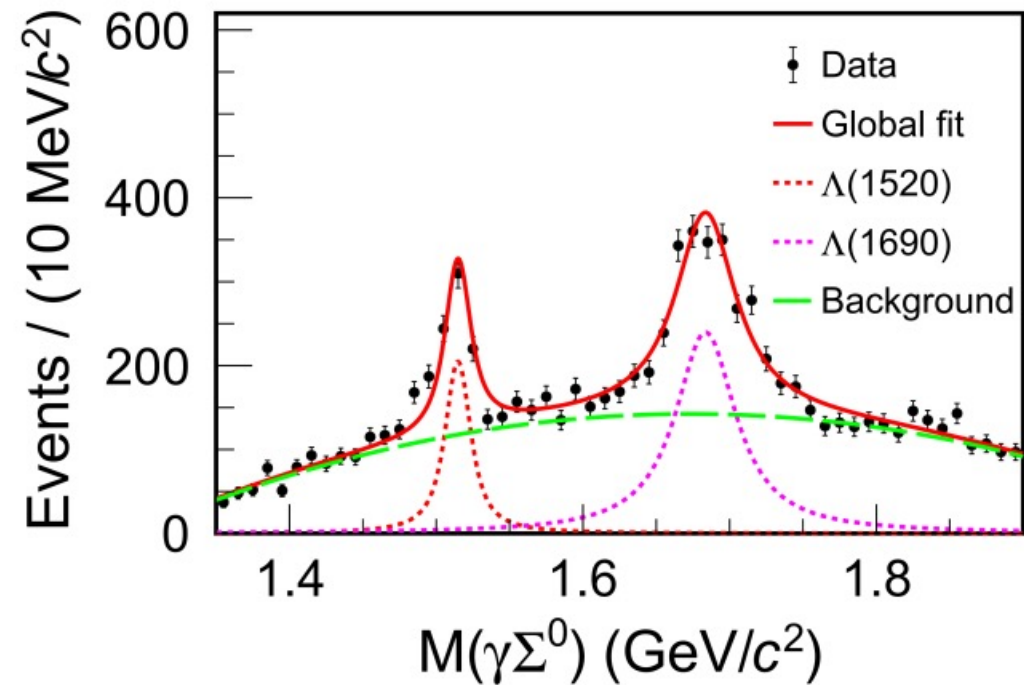
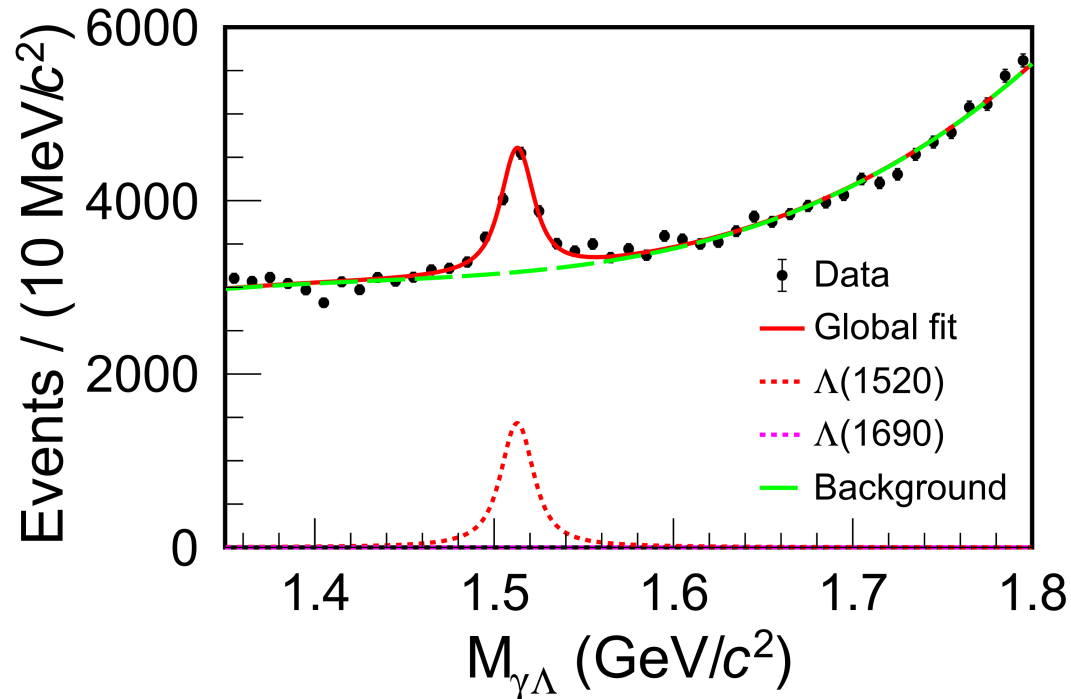

Summary and Outlook

- With partial wave analysis and mass spectrum fitting, BESIII precisely measured the mass, width, branching fractions of a series of excited states.
- We achieved the first high-precision measurement of baryon radiative decays (e.g., $\Lambda(1520/1690) \rightarrow \gamma\Sigma^0$) at BESIII, providing crucial experimental constraints for various theoretical models.
- Outlook
 - ◆ Further Measurements: Search for high-spin/highly excited states with future high-luminosity data.
 - ◆ Extended Studies: Extend to strong and semileptonic decays to constrain baryon structure.
 - ◆ Joint & Future: Combine with other experiments and provide input for future facilities

Thank you for your attention!