

Fast luminosity detector with LGAD

Yun-Yun Fan (樊云云), fanyy@ihep.ac.cn

On behalf of Fast lumiBell2 group.

¹Institute of High Energy Physics, Beijing

Mar. 11, 2026

Outline

- Motivation
- Prototype with pixel array LGAD
- Performance of LGAD at Belle II operation
 - Study of the sensitivity of LGAD
 - Degradation of the LGAD
- Summary

Motivation

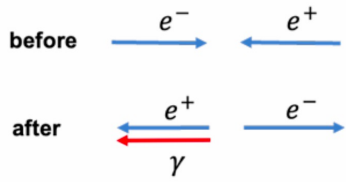

Luminosity	Cross section	Number of Bhabha	Aimed precision
5×10^{34}	0.127 barn	6.35×10^6 in 1ms	2% in 1ms

- Requirement for the lumi-detector

- Fast feedback
- Large area

- Advantage of LGAD

- Fast signal pulse: ~2 ns
- Large area
- Radiation hardness: 2 MGy
- low cost

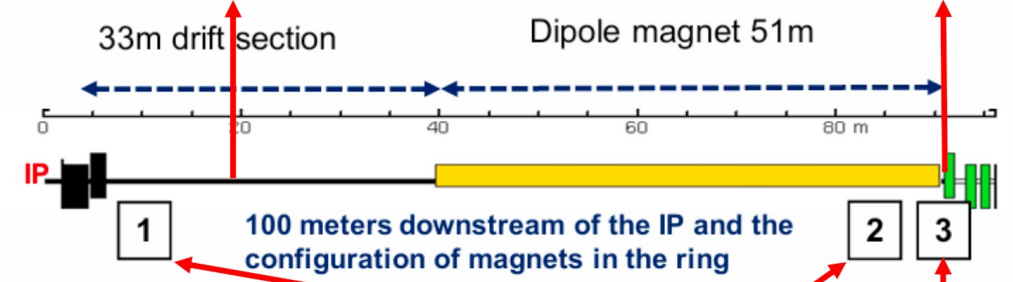
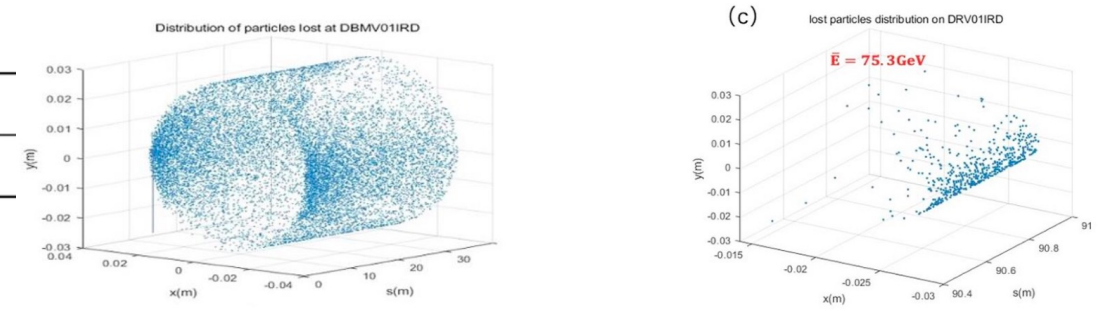

	Position1	Position2	Position3
Distance from IP	10m	84m	90.5m
Average Number detected/collision	3.4(two sides)	3(one side)	3.2(one side)
Average Number detected/ms	2830	2500	2670
Expected Measured Precision	1.9% @1kHz	2.0% @1kHz	1.9% @1kHz
Average Energy of scattered electron	24GeV	70GeV	75.3GeV
Average Hitting Angle	1.7×10^{-4} rad	7×10^{-4} rad	7×10^{-4} rad
Maximum Secondary Particle Position	88mm	104mm	105mm
Detection Area	$5 \times 20cm^2$	$3 \times 15cm^2$	$3 \times 15cm^2$
Backgrounds	SR Photons in 1 Side	-	-
Beam-Beam Deflection Impact	sensitive	less sensitive	less sensitive
Detector Number	2	1	1
Detector Measurement Parameters	Number of signals within 1ms		
Detector Time Resolution	600ns		
Detector technology possibility	LGAD, SiC, Diamond		

Motivation

- **the difficulty in increasing the luminosity of Belle II:**
 - bunch-by-bunch information for beam loss diagnostics.
 - As the accelerator collision interval is shortened (from 4 ns to 3 ns), the signal width of the existing diamond detector (4 ns) .

SuperKEKB (Electron-Positron Collider)

C.M.S. Energy: $\sqrt{s} = 10.58 \text{ GeV}$
 Luminosity: $L \rightarrow 8 \times 10^{35} \text{ cm}^{-2} \text{ s}^{-1}$
 (Luminosity Frontier Machine)

Achieved in 2024 : $L = 5.1 \times 10^{34} \text{ cm}^{-2} \text{ s}^{-1}$

	Electron	Positron
Energy (GeV)	7	4
Current (A)	3.6	2.6

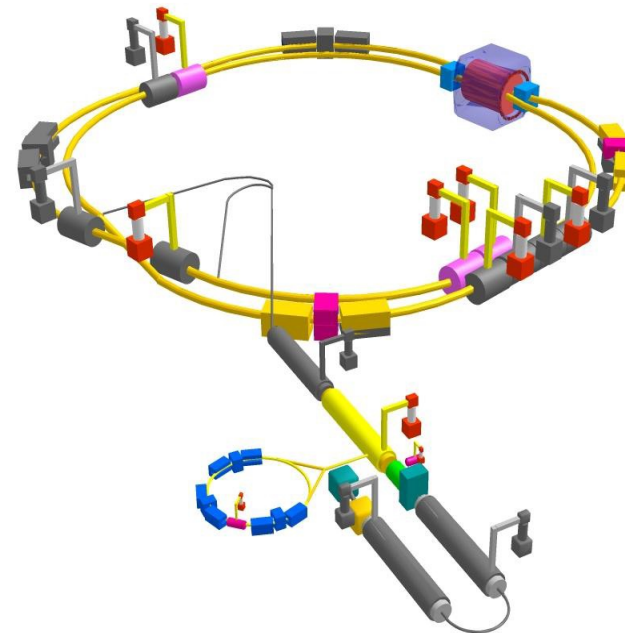

Propotype for CEPC fast luminosity detector

15 pixels

25 pixels

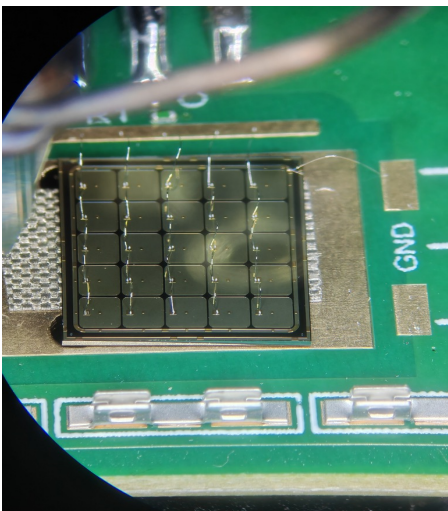
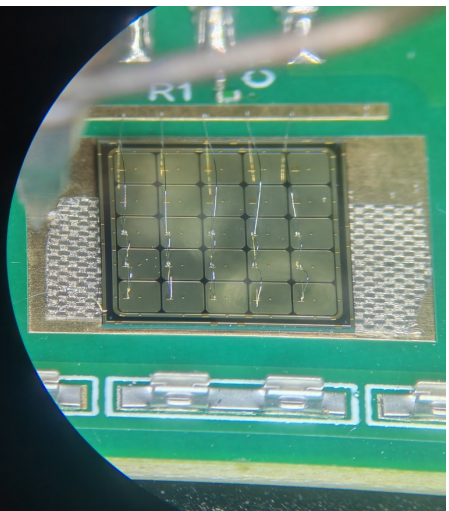

Beta source Test

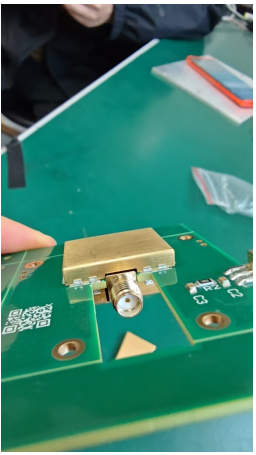

Performance of Large area LGAD

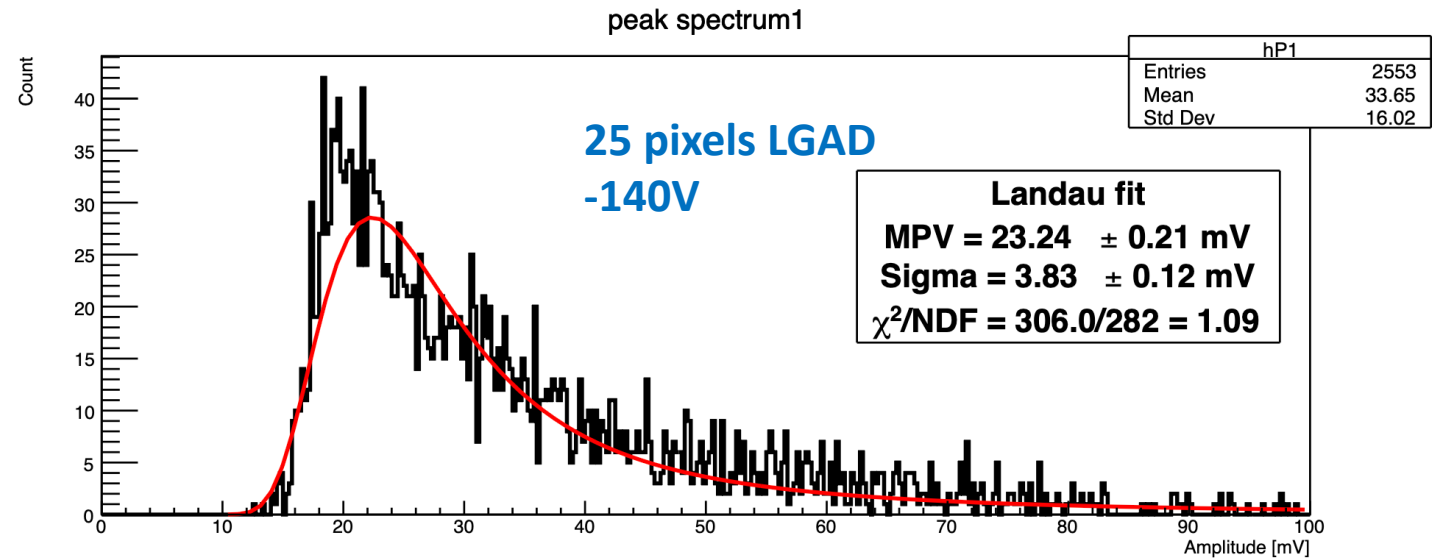
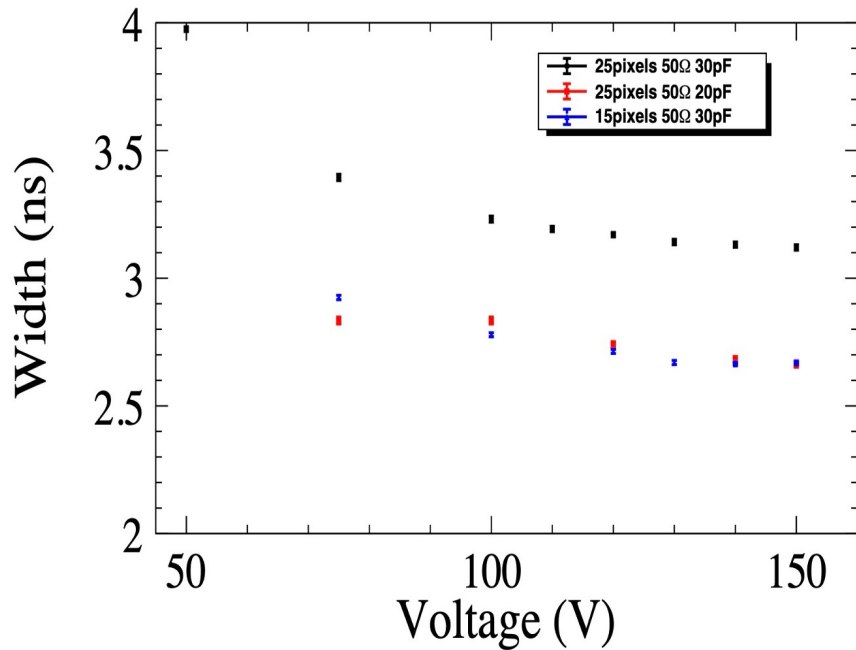

Installation of LGAD at Belle II

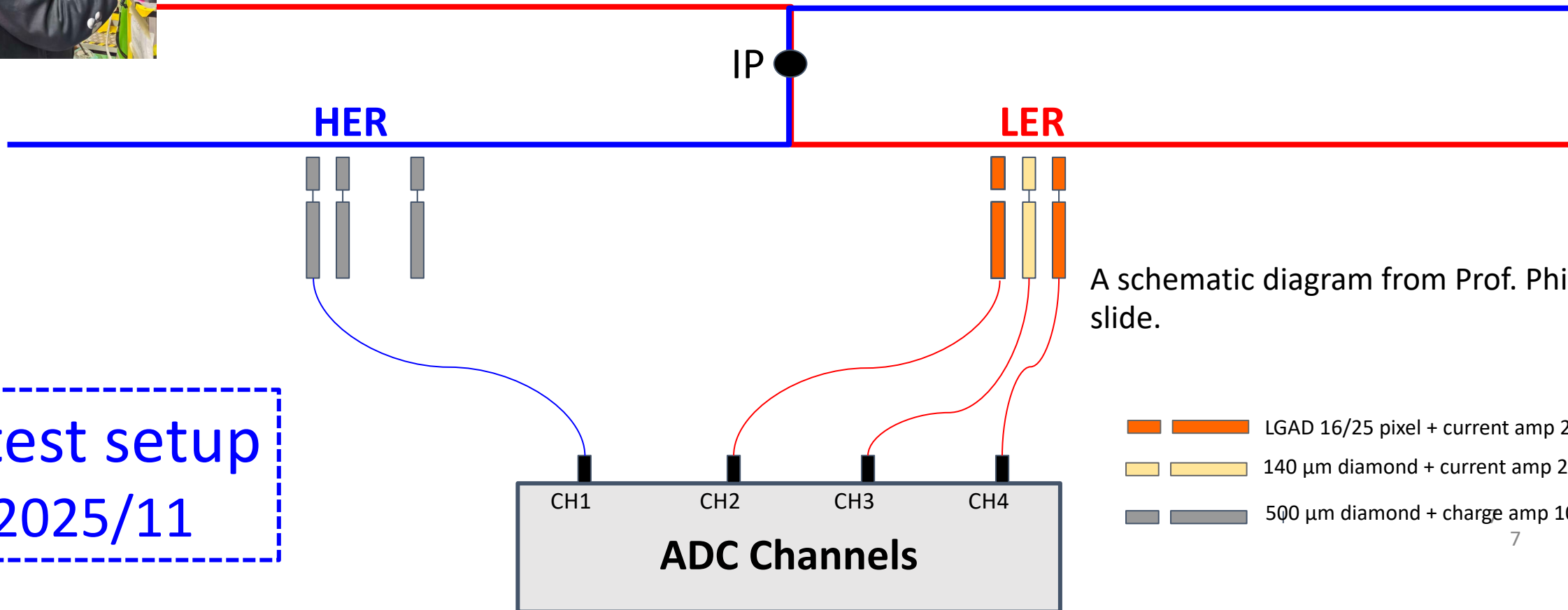
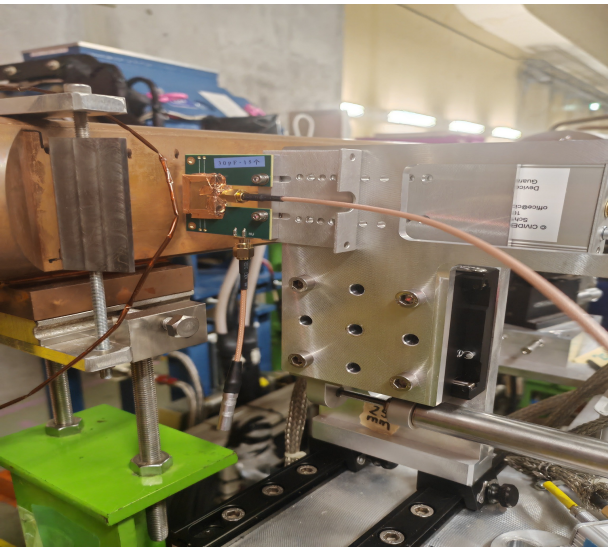

latest setup
2025/11

A schematic diagram from Prof. Philip's slide.

Results of the LGAD

Large-area LGAD detector's luminosity test data during beam operation at the SuperKEKB accelerator shows a signal significantly higher than that of a diamond detector. It can efficiently reflect the real-time bunch-by-bunch luminosity.

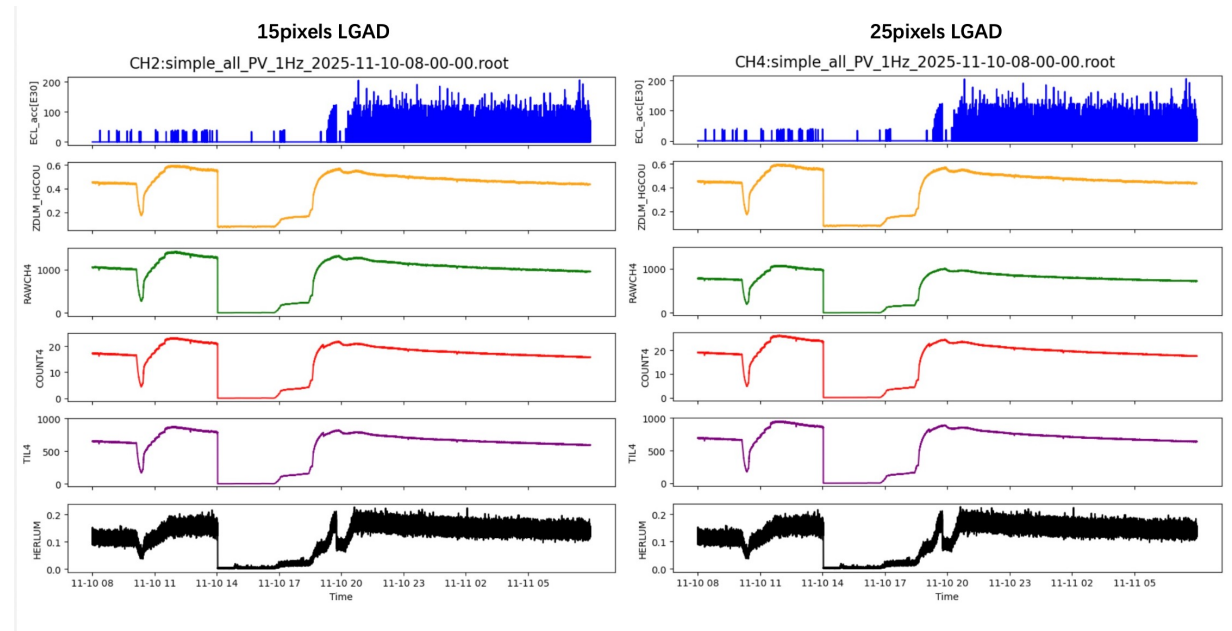
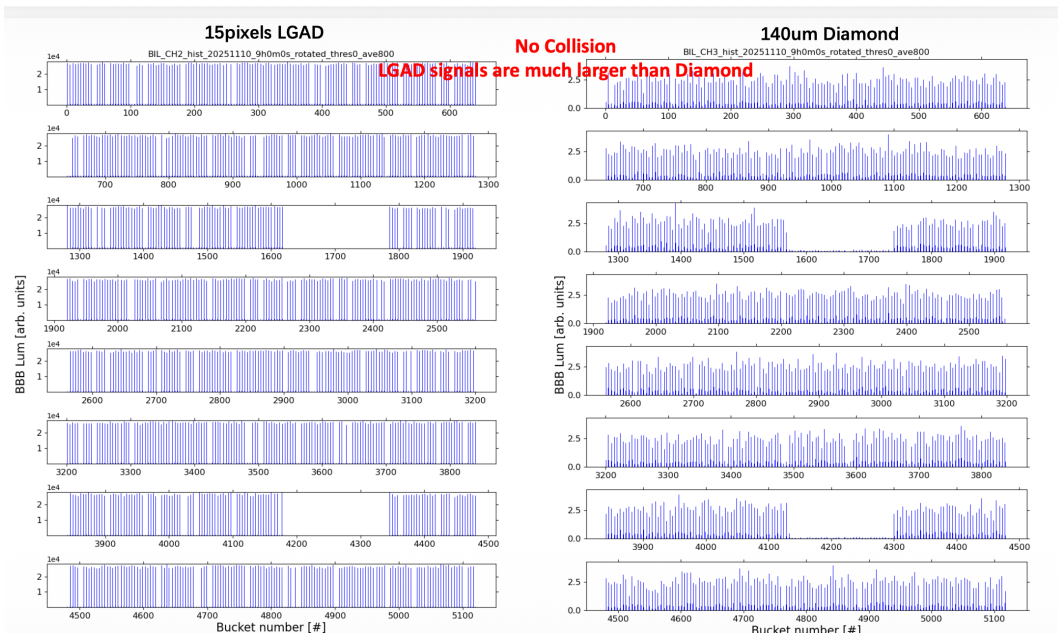

Methodology

- Select 10-second time intervals, during which the luminosity measured by ECL detector remains relatively **stable**.

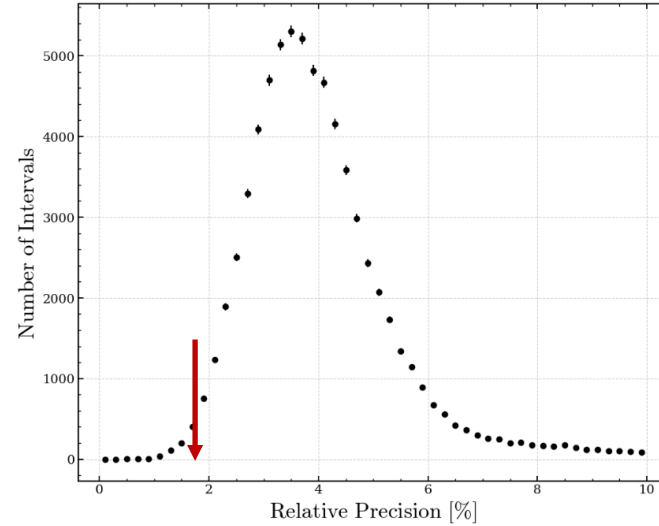
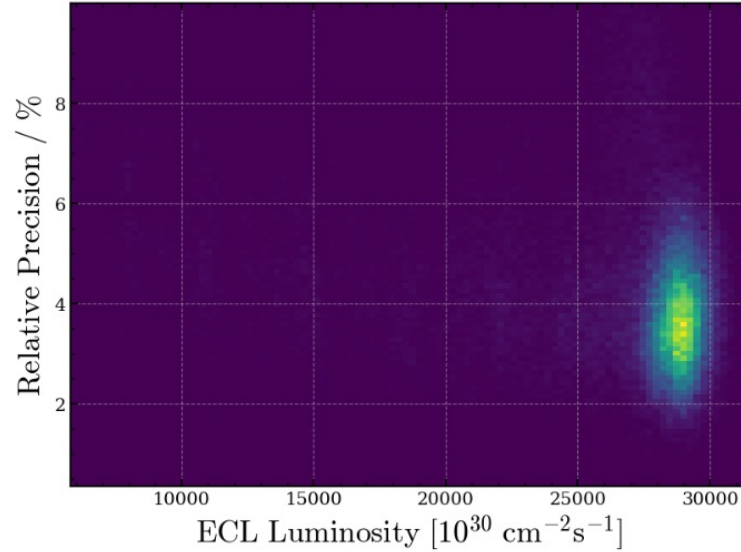

Relative Precision =

$$\frac{RMS(\text{ECL Lumi})}{Mean(\text{ECL Lumi})}$$

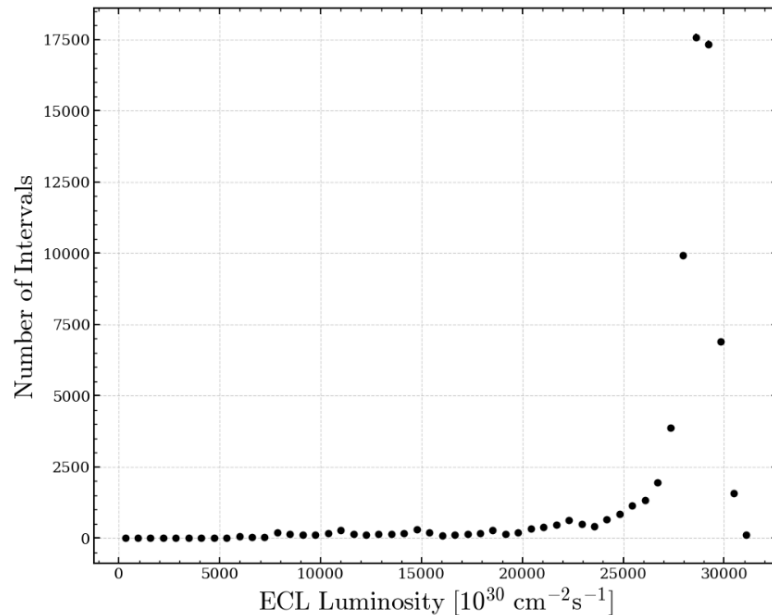

A **relatively stable time interval** is defined as one in which the relative precision of the ECL luminosity falls within **the lowest 5%**.

Data taken at 2025-12-15 as an example

Relative Precision of different channels

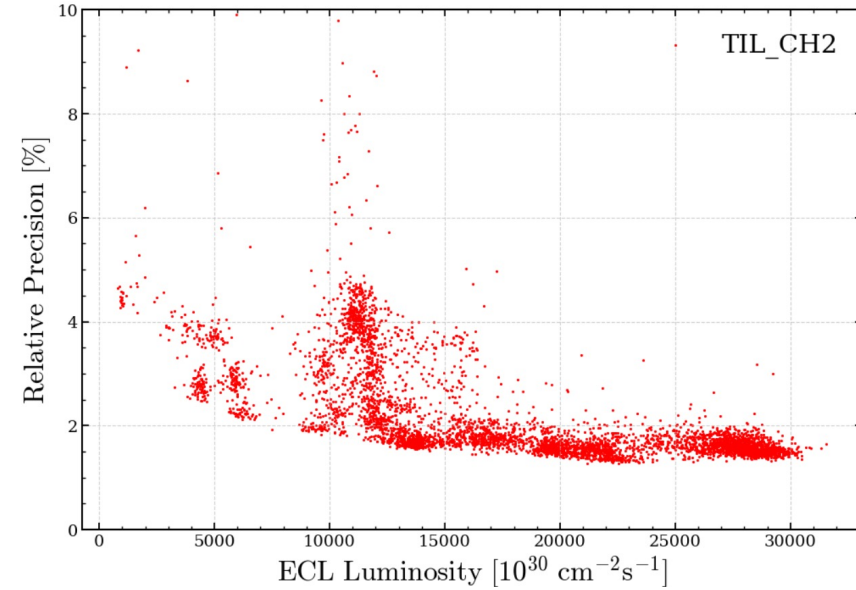
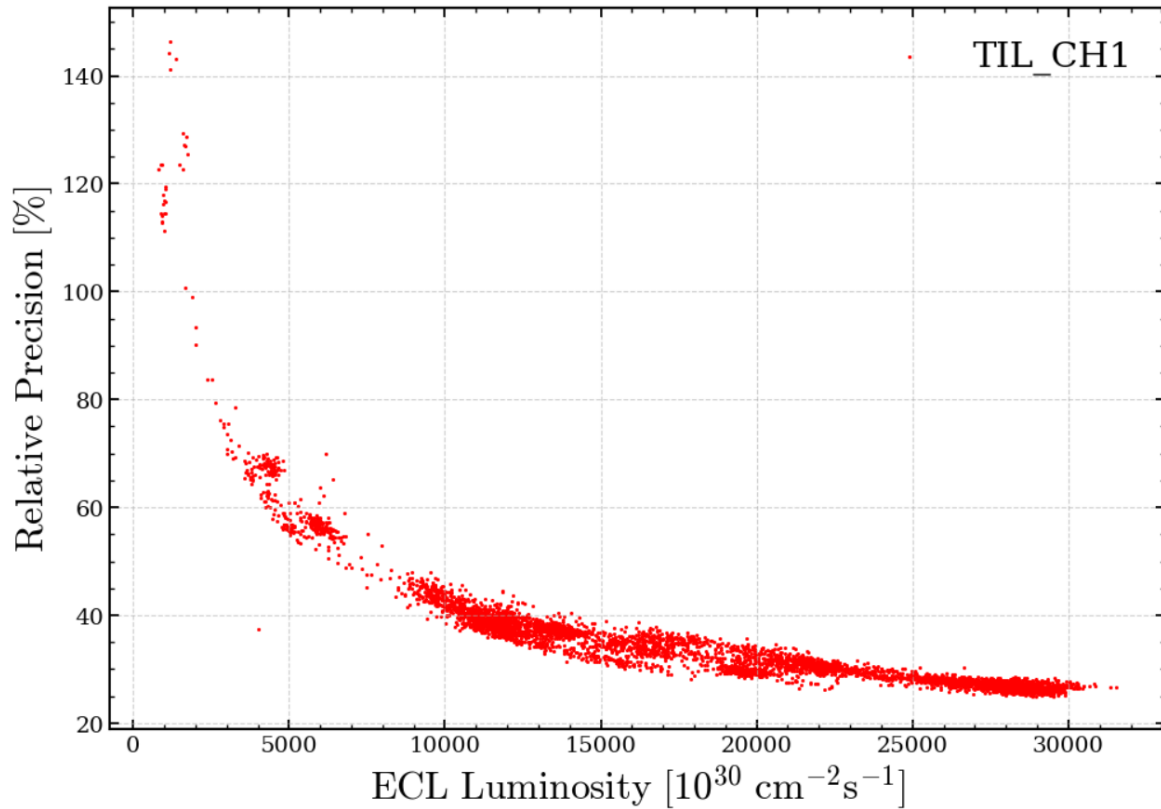

$RP \sim 2\%$

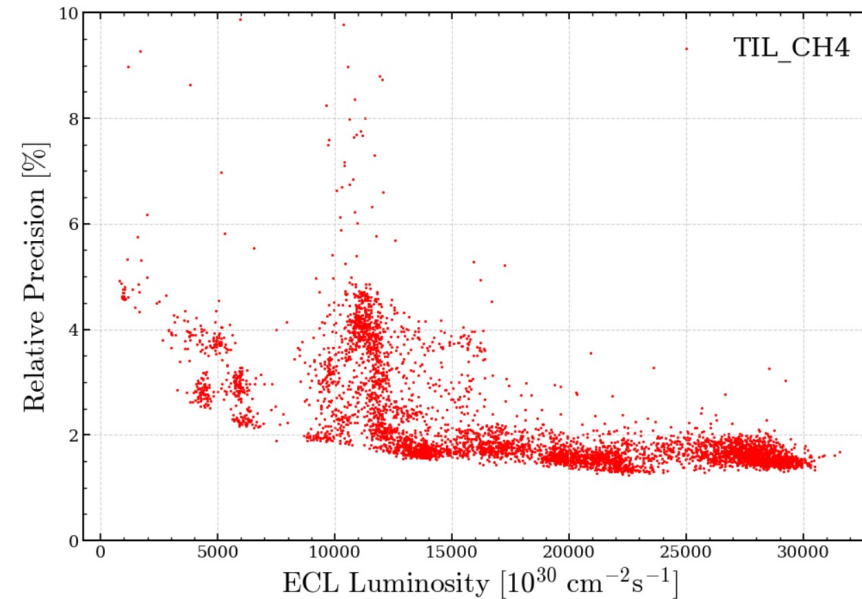

➤ The diamond sensor's precision has better consistency with this assumption but much worse than LGAD's.

Study of the Sensitivity of LGAD

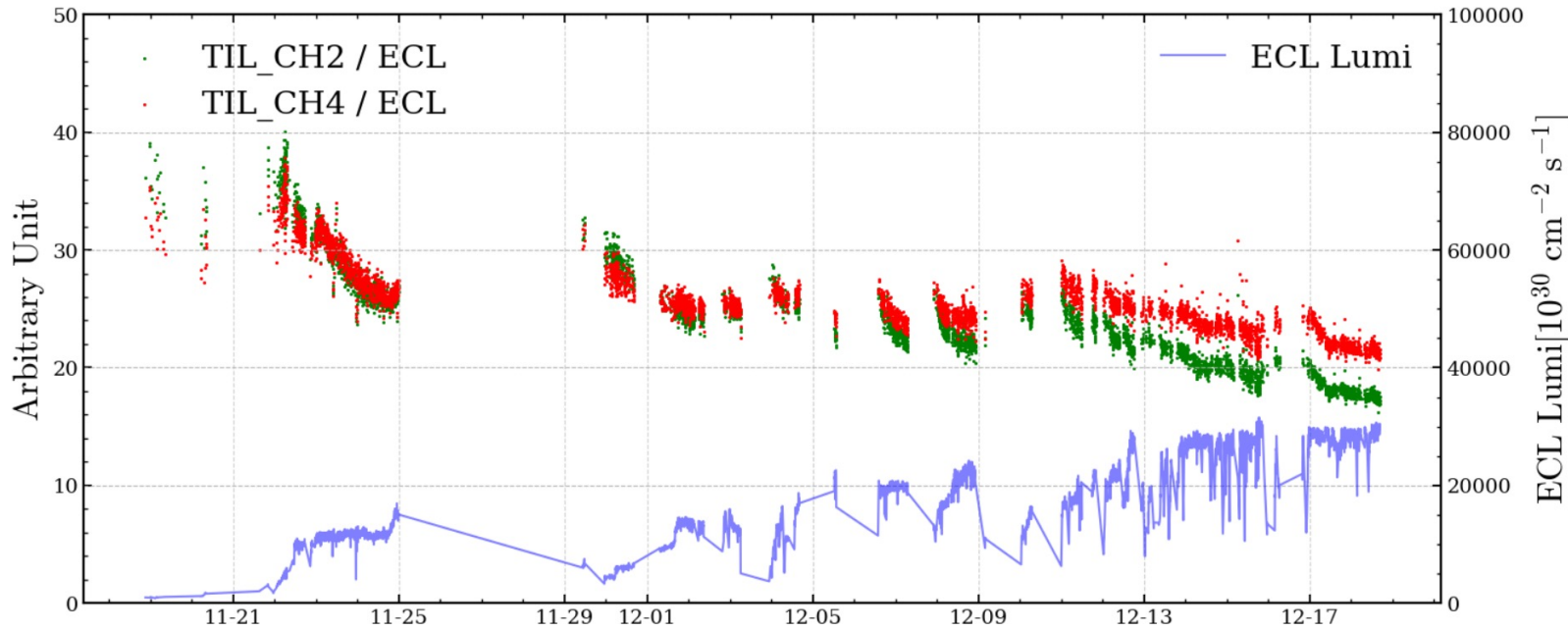

$$\text{Sensitivity}_i = \frac{\text{mean of 1kHz data}}{\text{ECL Lumi}} \text{ in } i^{\text{th}} \text{ stable time interval,}$$

Mean of 1kHz data: μ for CH1,2,4, MPV for CH3

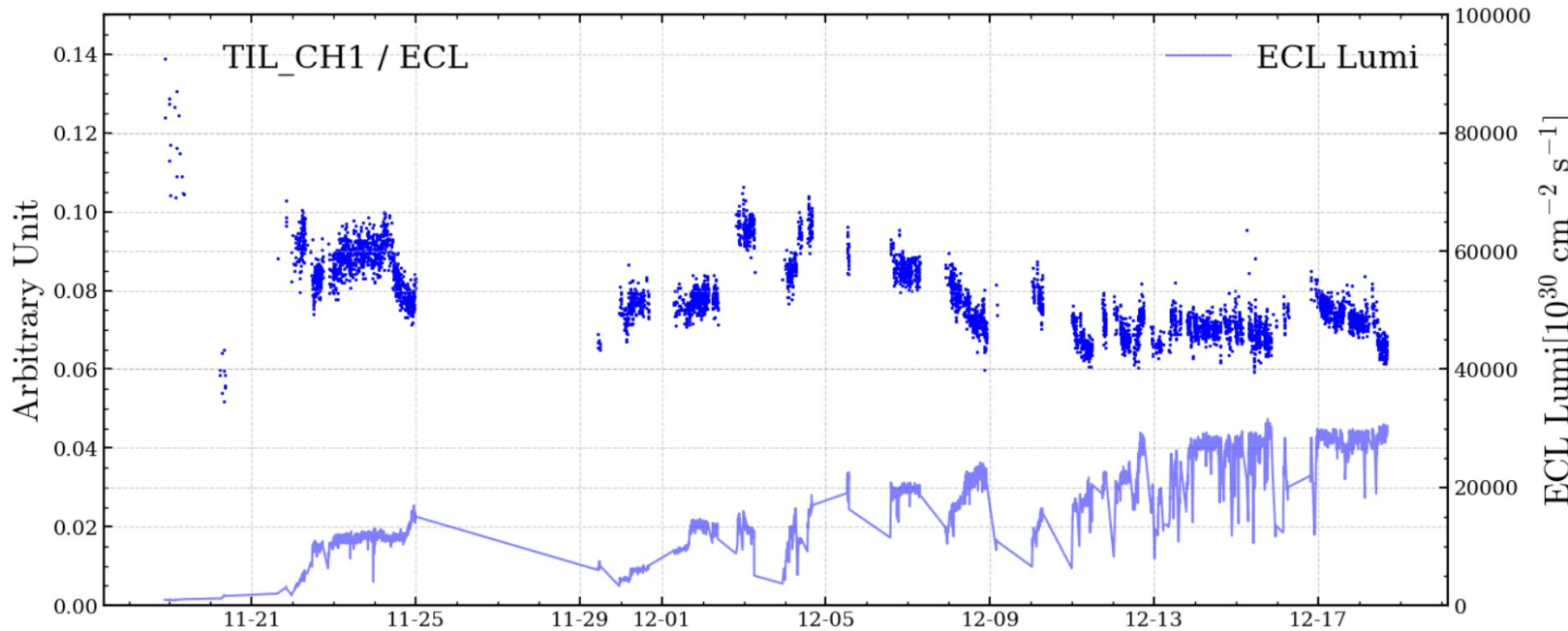

➤ The difference between two LGADs becomes larger as time goes on.

All Data from Nov. 19th to Dec. 19th

Study of the Sensitivity of LGAD

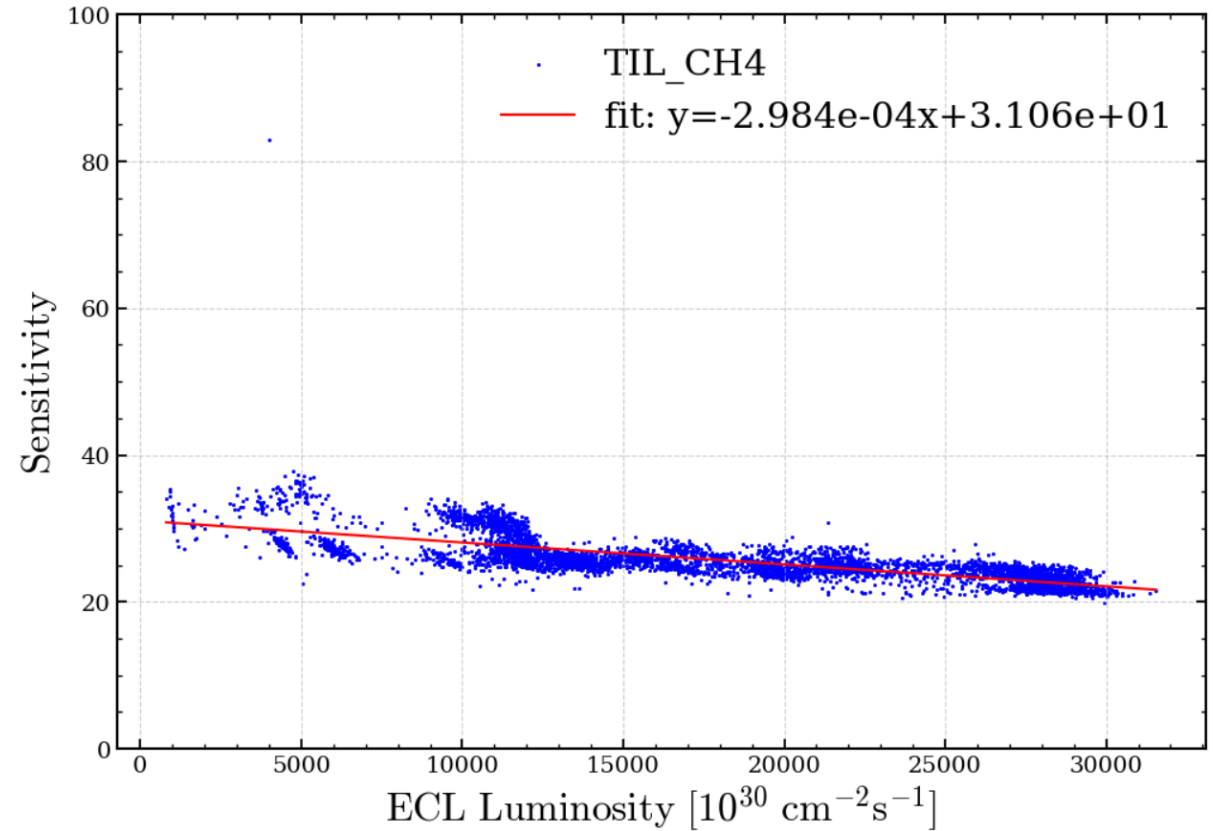
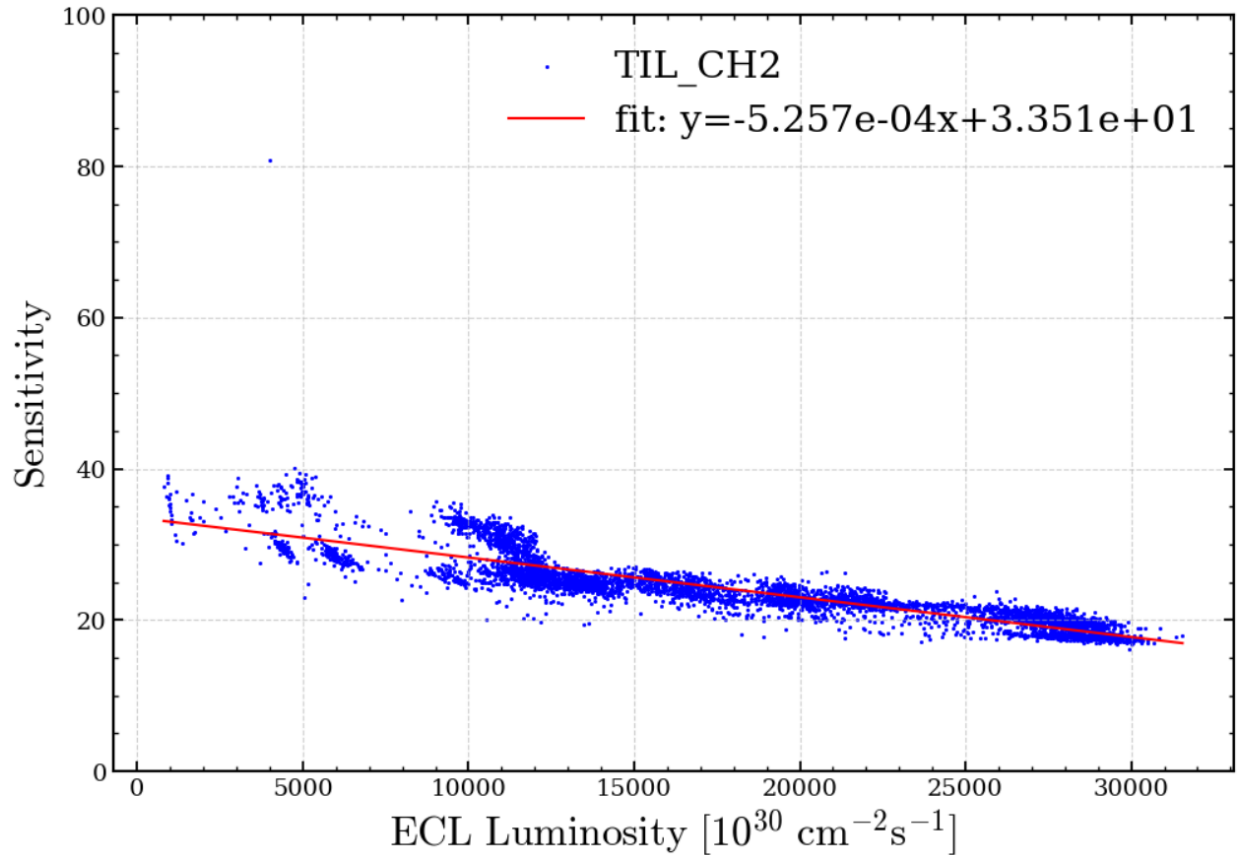

All Data from Nov. 19th to Dec. 19th

Summary

- **Using this method, the behavior of relative precision of LumiBelle2 with respect to ECL luminosity is studied.**
- **LGAD has much better performance than diamond sensors at relative precision aspect. Relative sensitivity is ~2% during one month period**