



Diamond detector for CEPC Fast luminosity monitoring

Suen Hou, Jialiang Zhang, Lei Zhang

On behalf of the CEPC LumiCal team

CEPC Luminosity detector

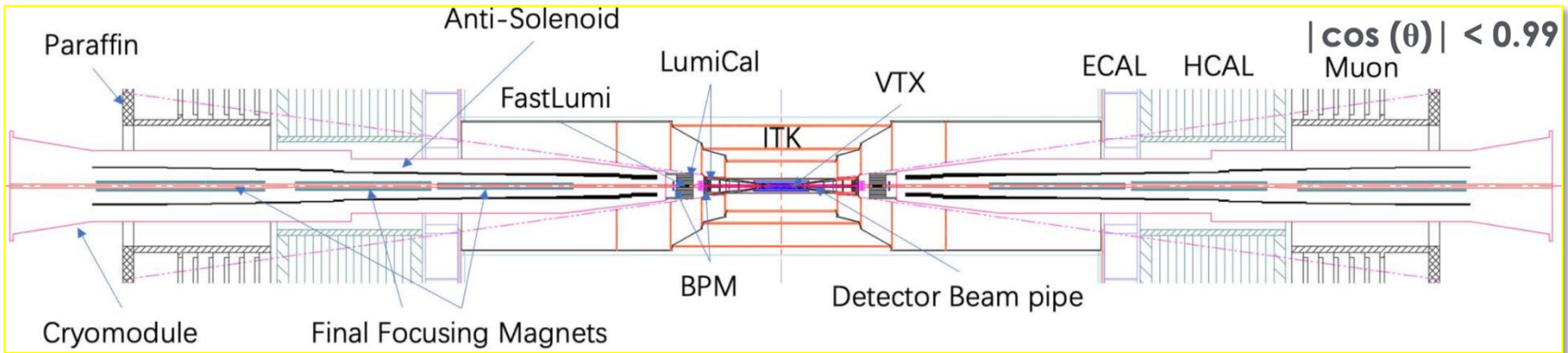

- Fast beam monitor: diamond detector option

- $z=800-1050$ mm, $y = \pm 12$ mm, $x - +27$ mm;
- ~ 10 mRad, highest radiation field at CEPC

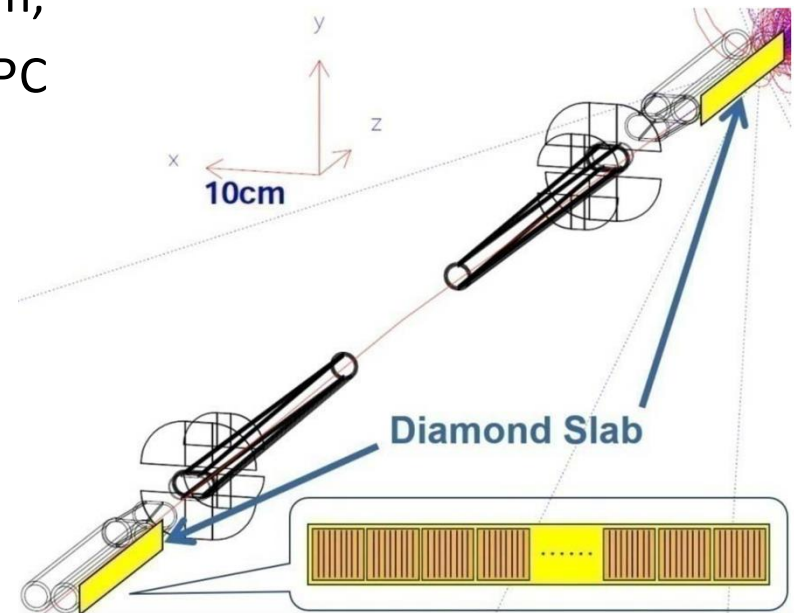
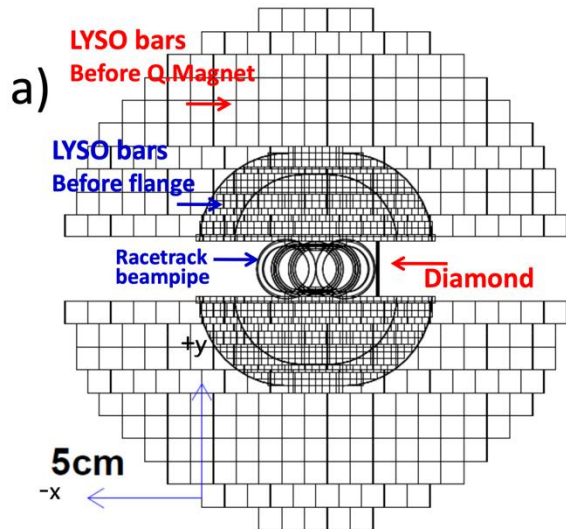

Fast Luminosity monitor

- Fast and real time luminosity measurements:
 - Sum of events from showering and directly traversing electrons.
- IP displacement along z-axis (x,y monitored by BPMs)
 - Differentiate rates on +z v.s. -z to estimate IP offset
 - Shower generated in 3 mm copper beam pipe, RMS about 30 mm
 - E.g. with 2 mm strip pitch, IP precision: ~ 0.1 mm for x, 10 mm for z

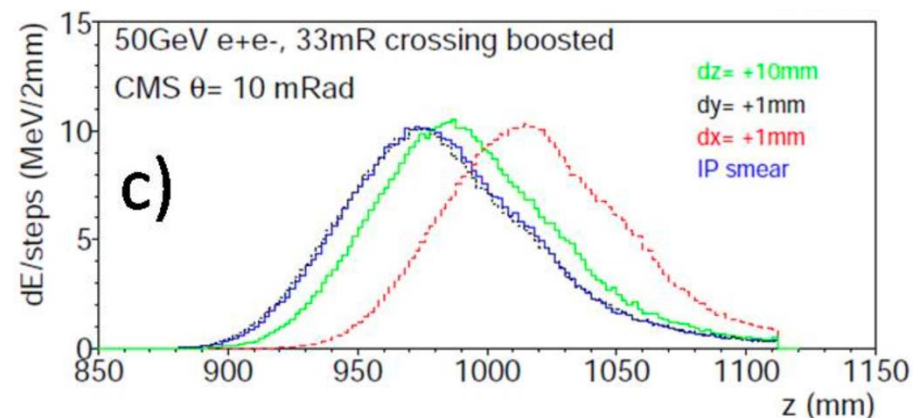
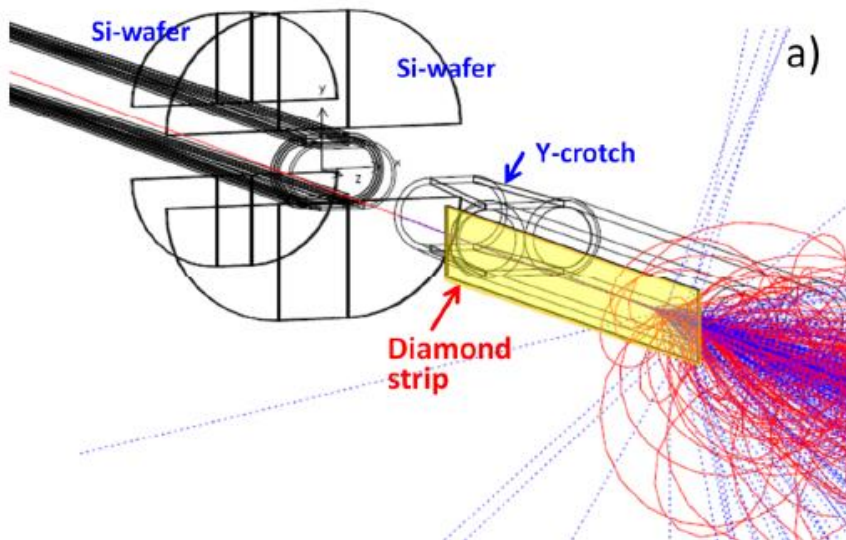

Design of Diamond Slab

- Detector at each side consists of 12 CVD diamond sensors
 - CVD diamond sensors: $20 \times 20 \text{ mm}^2$, thickness of $500 \mu\text{m}$
 - Strip: 19mm long and 0.9mm wide, with 0.1mm gap, (1 mm pitch)
- Charge collection
 - MIP: $>32,400$ charges ($\sim 5.2 \text{ fC}$) per y-pitch;
 - 240 electrodes in y direction and 20 in z direction

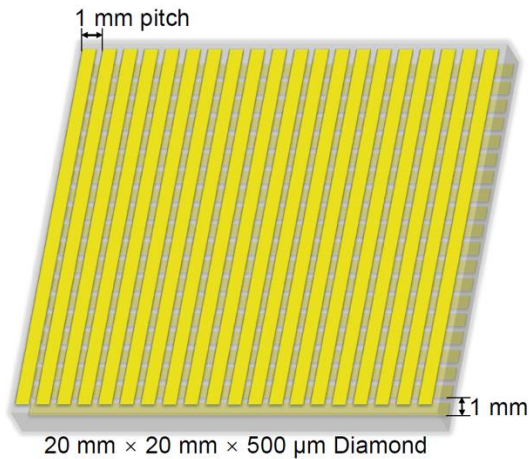

Microstrip diamond sensor

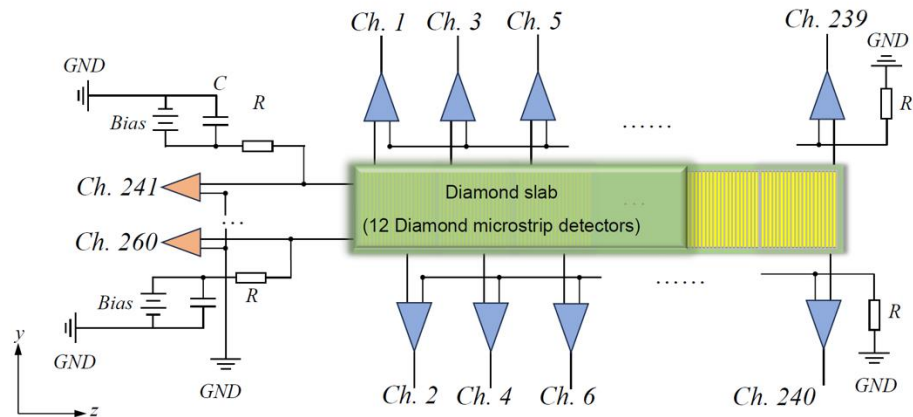

Microstrip readout for a diamond slab

Fabrication and Test

- Test module fabricated and tested
 - An “old” $1 \times 1 \text{ cm}^2$ and $300 \text{ }\mu\text{m}$ polycrystal CVD diamond
 - 1 mm electrode pitch using micro-fabrication processes;
 - $\sim 100 \text{ pA}$ leakage current under $1 \text{ V}/\mu\text{m}$
- Full diamond slab prototype and the associated beam tests planned in the next stage.

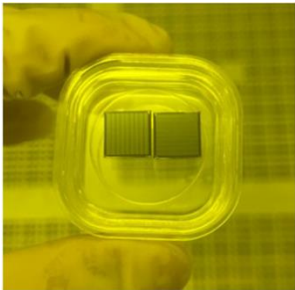

Fabrication of Diamond sensor

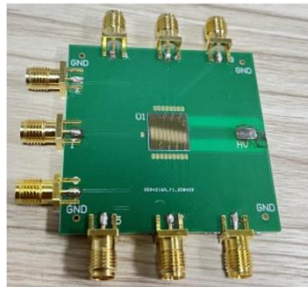

Diamond Test module

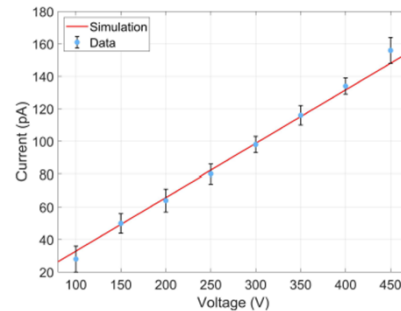

I-V characteristics

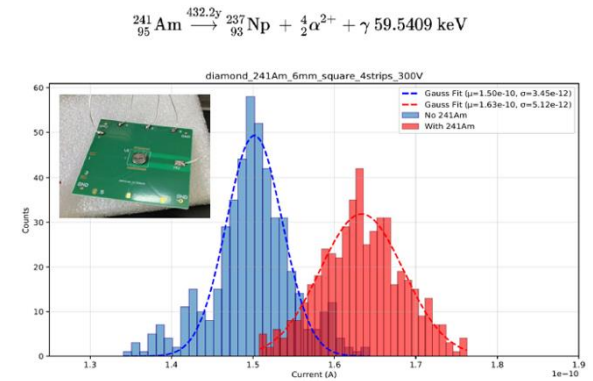

Current-integrated signal response to ^{241}Am

Next Steps of Diamond FastLumi Monitor

- Step 1: Development of Diamond Sensors
 - Study both single-crystal $10 \times 10 \text{ mm}^2$ and polycrystalline $20 \times 20 \text{ mm}^2$
 - Fabricate 2-D diamond sensors with 1 mm pitch electrodes on both sides
 - Develop readout electronics: low-noise preamp and high-speed DAQ
 - Sensor characterization, e.g. response, time/spatial resolution, etc.
- Step 2: Prototype of Diamond Slab
 - Readout electronics for diamond slab prototype (multi-sensor array), e.g. PCB design, multi-channel low-noise preamp, and ASIC/FPGA based DAQ
 - Beam test and performance characterization of the detector prototype.

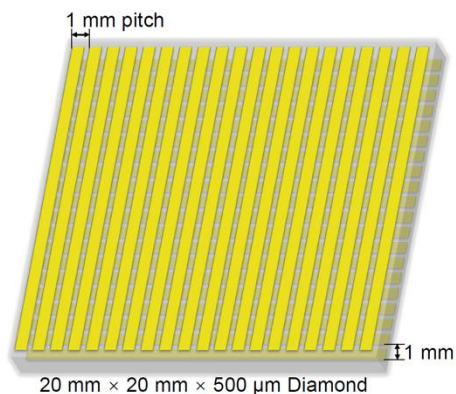

Microstrip diamond sensor

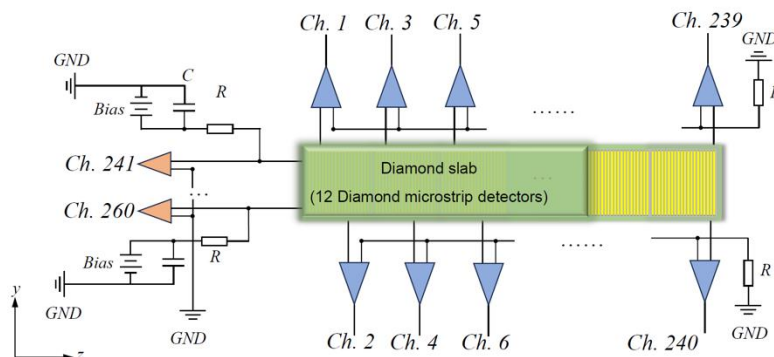

Microstrip readout for a diamond slab

Next Steps of Diamond FastLumi Monitor

Beijing Baoming
Technology Co., Ltd.

- Types of diamond wafers planned for purchase:

No.	Sample Type	Size Specification	Surface Quality	Nitrogen Content	Single crystal quality	Price per Piece (RMB)	Piece(s)	Price (RMB)
1	Polycrystal Diamond (Electronic Grade)	20×20×0.5mm ³	Double-sided polished, Ra≤30nm	N≤50ppb	/	14,050	5	70,250
2	Polycrystal Diamond (Electronic Grade)	20×20×0.4mm ³	Double-sided polished, Ra≤30nm	N≤50ppb	/	14,050	2	28,100
3	Polycrystal Diamond (Electronic Grade)	20×20×0.3mm ³	Double-sided polished, Ra≤30nm	N≤50ppb	/	14,050	2	28,100
4	Single Crystal Diamond (Electronic Grade)	10×10×0.3mm ³	Double-sided polished, Ra≤30nm	N≤50ppb	X-ray double crystal rocking curve FWHM: ≤0.015° (53arcsec)	10,000	6	60,000
5	Single Crystal Diamond (Electronic Grade)	10×10×0.4mm ³	Double-sided polished, Ra≤30nm	N≤50ppb	X-ray double crystal rocking curve FWHM: ≤0.015° (54arcsec)	10,900	6	65,400
6	Single Crystal Diamond (Electronic Grade)	10×10×0.5mm ³	Double-sided polished, Ra≤30nm	N≤50ppb	X-ray double crystal rocking curve FWHM: ≤0.015° (55arcsec)	10,900	6	65,400
Total Price								317,250

Budget Estimate:

- Electronic Grade Diamond Material Cost: 317,250 RMB
- Micro/nano-fabrication and tests: ~ 350,000 RMB
- Electronics (PCB, pre-amp, etc.) : ~ 300,000 RMB

Tests at BESIII experiment

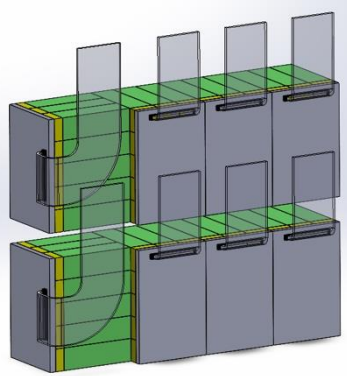

$3.3\text{m} < z < 3.5\text{ m}$,
 $\theta = 0$ in CMS frame

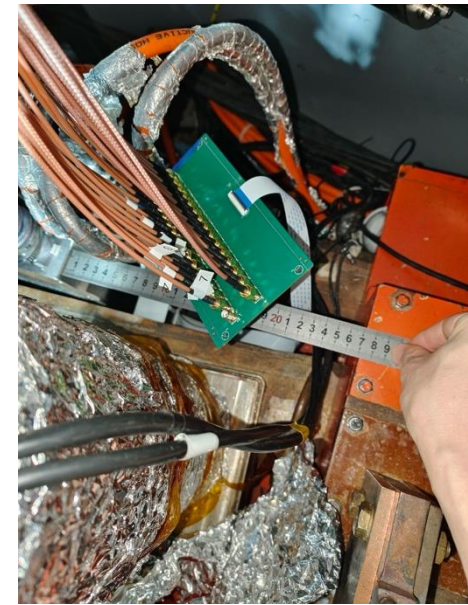
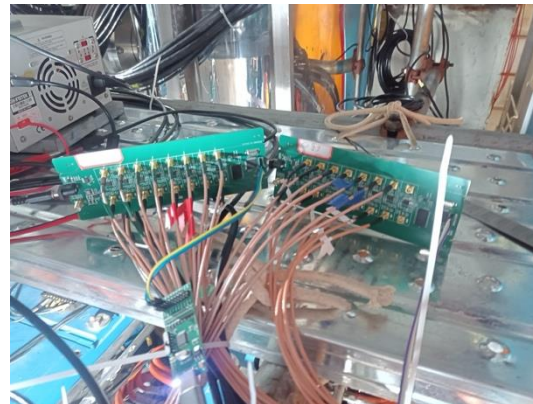
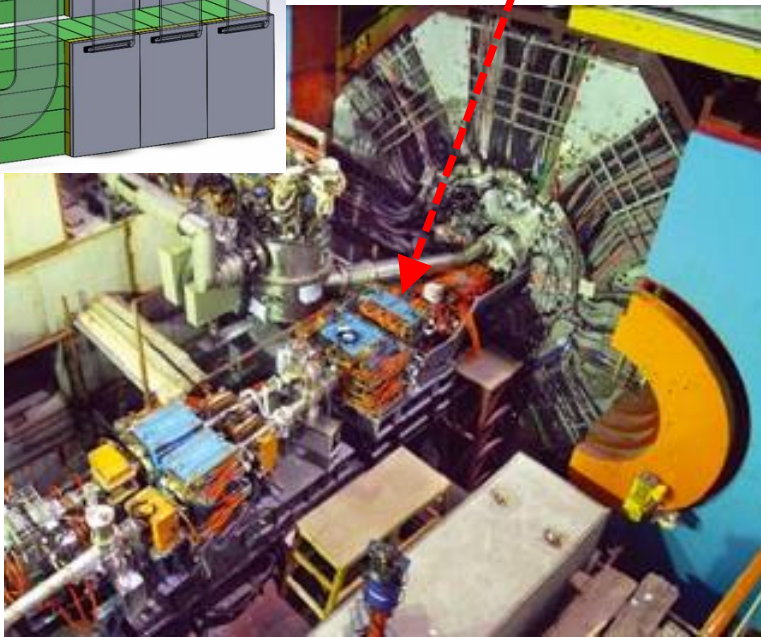

Summary

- Diamond radiation hardness has been extensively studied
- Diamond sensor based CEPC fast lumi. detector
 - Design and simulation performed
 - Micro-fabriaction procedure tested with an old diamond sensor
 - Test with alpha-sources performed
- **Next Steps of Diamond FastLumi Monitor**
 - Sensor fabrication with high quality diamond sesnors
 - Readout electronics R&D
 - Detector size prototyping
 - Test at BESIII experiment
 - Budget Estimate: about 1 M RMB in total

Back up

Schematic of Diamond slab

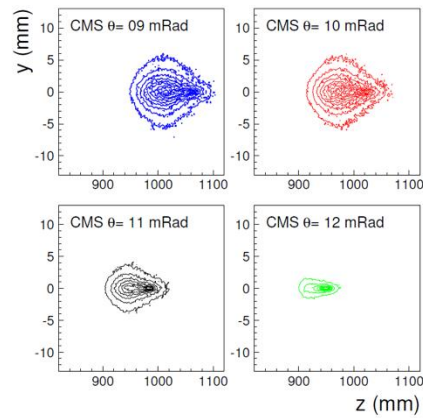

Shower profiles of different Bhabha electron angles

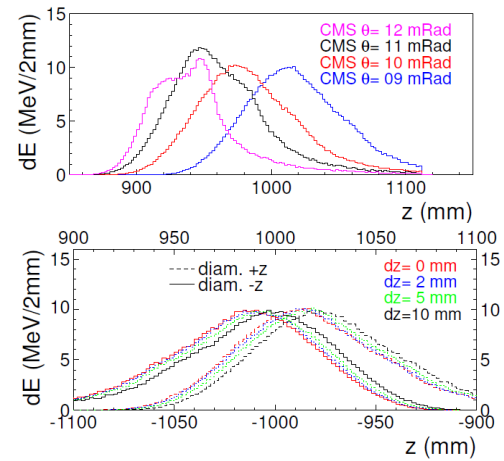

Energy-loss (dE/dx) deposition along z-axis and shower distribution with IP offsets

Introduction

The e^+e^- collision luminosity is measured by counting Bhabha elastic scattering in the Luminosity Calorimeter (LumiCal) with silicon position detectors and rad-hard LYSO crystals with the precision depending on the acceptance fiducial edges.

The leading order of Bhabha cross section, integrated over an angular coverage of ($\theta_{min} < \theta < \theta_{max}$), is

$$\sigma = \frac{16\pi\alpha^2}{s} \left(\frac{1}{\theta_{min}^2} - \frac{1}{\theta_{max}^2} \right)$$

The QED calculation for Bhabha interaction is precise to next-to-leading order (NLO) of $e^+e^- \rightarrow e^+e^-\gamma$.

The integrated luminosity (\mathcal{L}) with Nacc Bhabha events detected is,

$$\mathcal{L} = \frac{1}{\epsilon} \frac{N_{acc}}{\sigma}, \quad \frac{\Delta\mathcal{L}}{\mathcal{L}} \sim \frac{2\Delta\theta}{\theta_{min}}$$

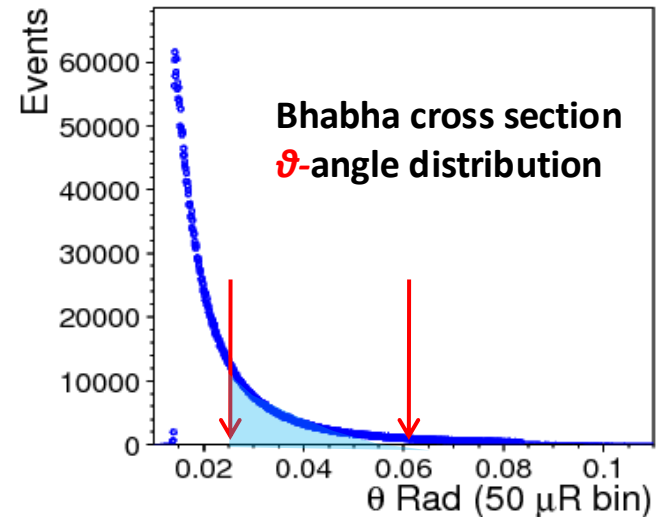

Fast luminosity diamond monitor for CEPC

Introduction

Assist beam steering by observing scattering of electrons on both z-sides. The electrons shower profiles are observed event by event. The integrated events pattern/rates along the z-positions can help monitoring the z-position of IP.

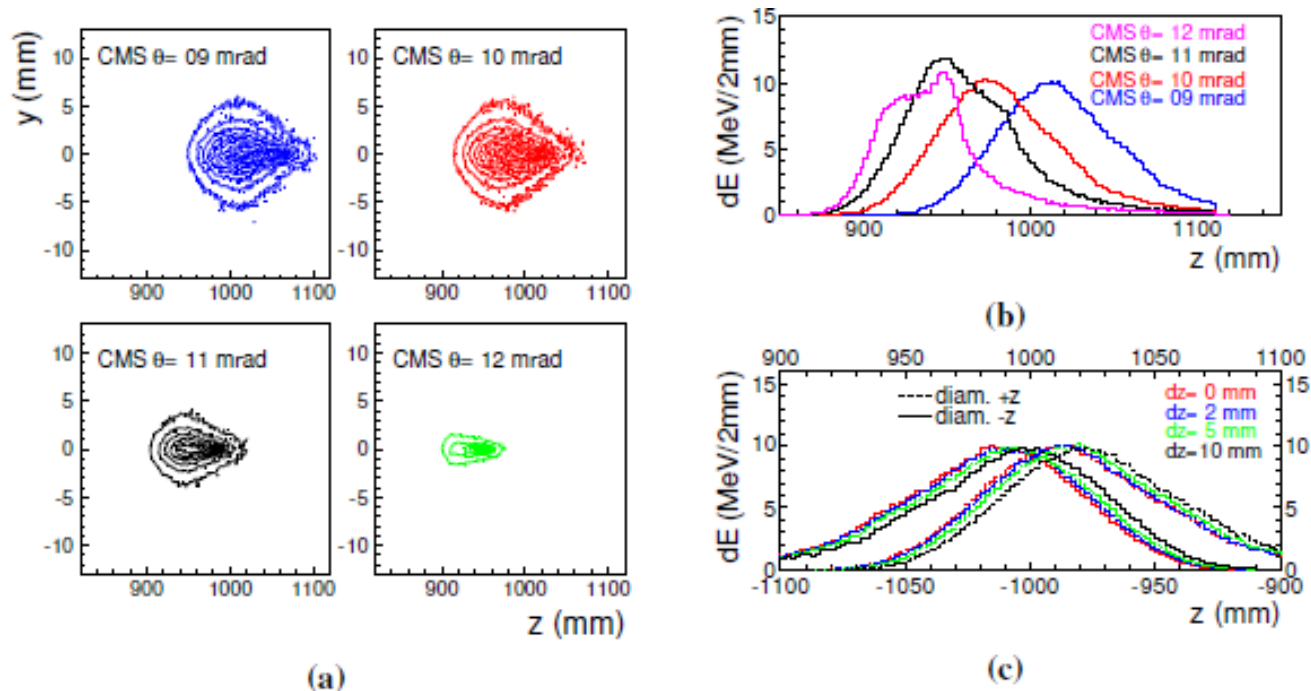

Fast luminosity diamond monitor for CEPC

Introduction

- **Event rate**

- Diamond slab covering 8~15 mRad (CMS)
- X-sec order of $\sim 10^2$ nb
- Event rate at Z-pole, $L=1 \times 10^{36}/\text{cm}^2\text{s}$,
- rate = $(100 \times 10^{-33}) \times (1 \times 10^{36})/\text{s}$
= ~ 100 kHz

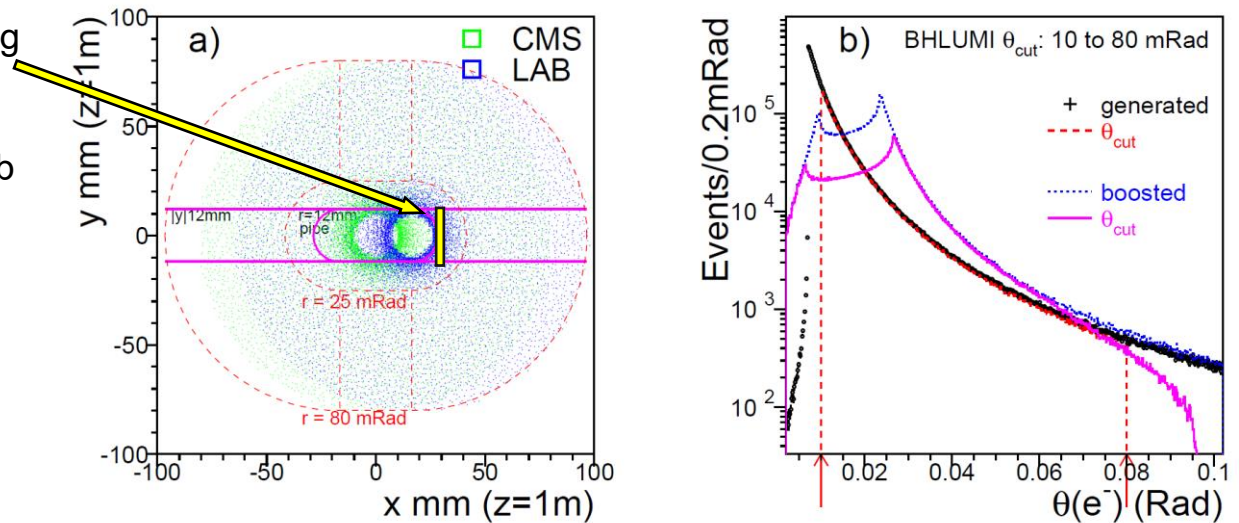

Figure 1.10 a) scattered electron distributions of BHLUMI simulations at CMS frame and after boost for the 33 mRad beam crossing at CEPC. Events are generated for $10 < \theta < 80$ mRad. The Acc0, Acc1 are selections according to the BHLUMI for LEP applications. b) the back-to-back angles of e^+ and e^- are plotted for the generated and boosted, and the Acc0 selected with and without radiative photon.

Fast luminosity diamond monitor for CEPC

Introduction

The most radiation tolerant detector to be considered is a diamond slab segmented in strips to detect electron showers generated in the copper beam pipe

- 2 diamond slab at $|z| = 855\sim 1110$ mm,
- $x = -27$ mm,
- y from -12 mm to 12 mm

The fast luminosity monitor slab is propose for an assembly of 12 diamond sensors ($20\text{mm}\times 20\text{mm}$) comprises a total 240 strips, with a 1 mm pitch

- Integral event counts $\sim 100\text{kHz}$
- Identify the shower pattern $\sim 1\text{mm}$ resolution

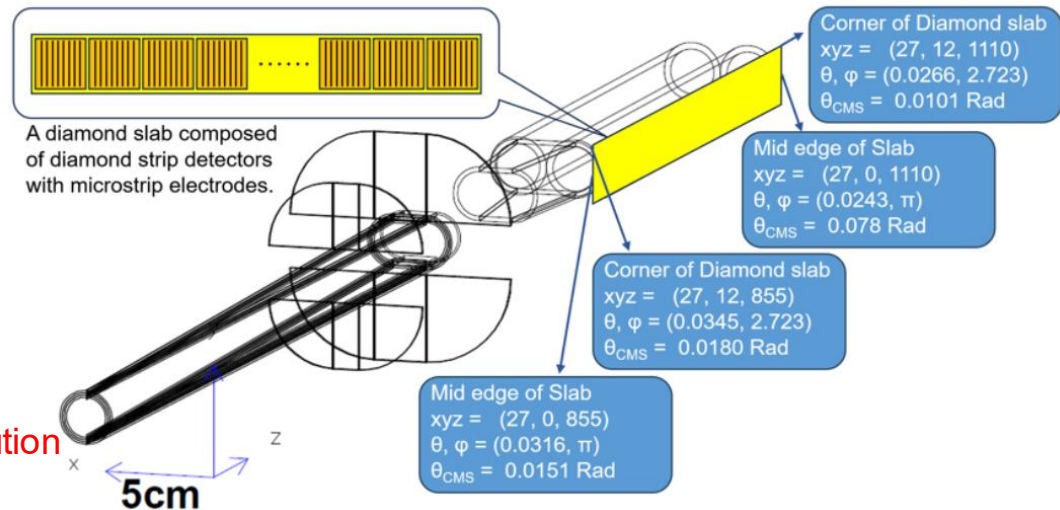

Fast luminosity diamond monitor for CEPC

Diamond sensors

The most radiation tolerant detector to be considered is a diamond slab segmented in strips to detect electron showers generated in the copper beam pipe

- 2 diamond slab at $|z| = 855\sim 1110$ mm,
- $x = -27$ mm,
- y from -12 mm to 12 mm

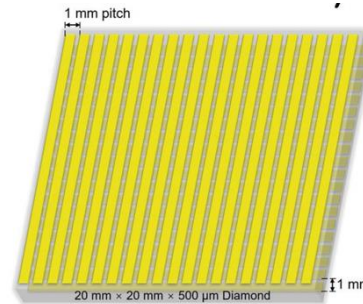

The fast luminosity monitor slab is propose for an assembly of 12 diamond sensors (20mm×20mm) comprises a total 240 strips, with a 1 mm pitch

- Integral event counts $\sim 100\text{kHz}$
- Identify the shower pattern $\sim 1\text{mm}$ resolution

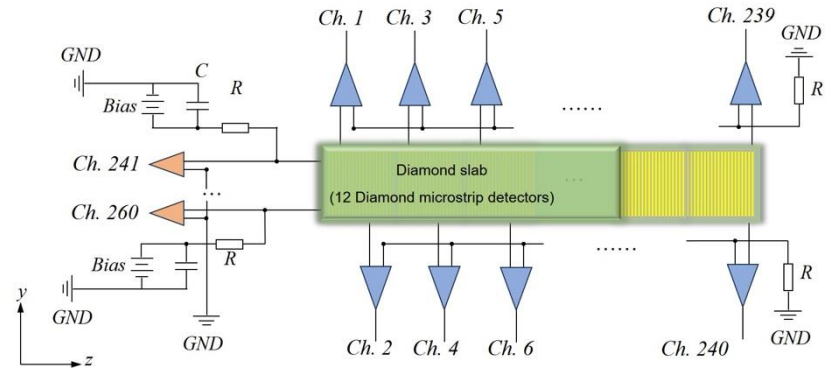

Fast luminosity diamond monitor for CEPC

Test of Diamond sensors

- IV test of 2 polycrystalline diamond
- Dark current around 50~100 pA with 1V/ μm
- Ohmic contact on surface

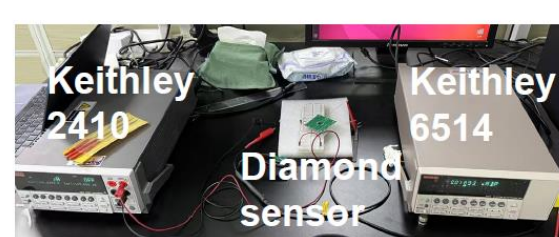

IV test setup

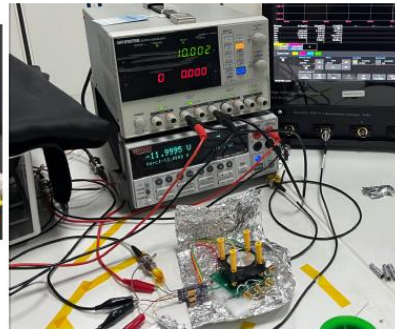

$^{90}\text{Sr}/^{241}\text{Am}/^{60}\text{Co}$ test setup

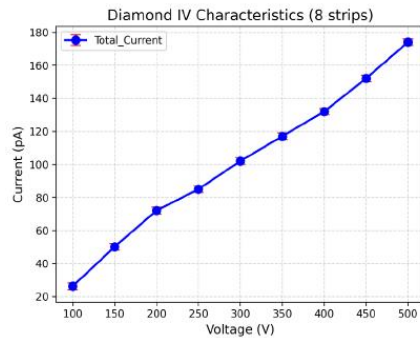
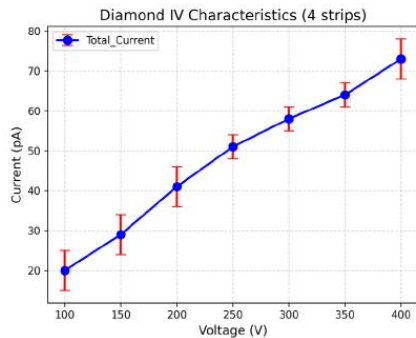

- Current-integrated signal response to ^{241}Am

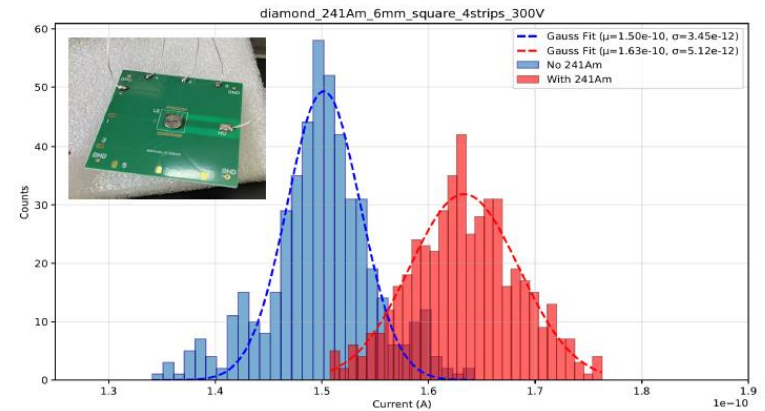
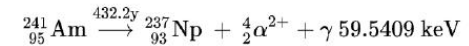

- Efforts are ongoing to obtain high-quality single-crystal diamond and low-noise amplification techniques for enhanced pulse signal acquisition.