

- **Status of TPC R&D**

# Production of TPC module : Mesh improvements

- Impartments of mesh production:
  - Stainless steel pressure bars & Al alloy flat plates: improved fabrication in progress

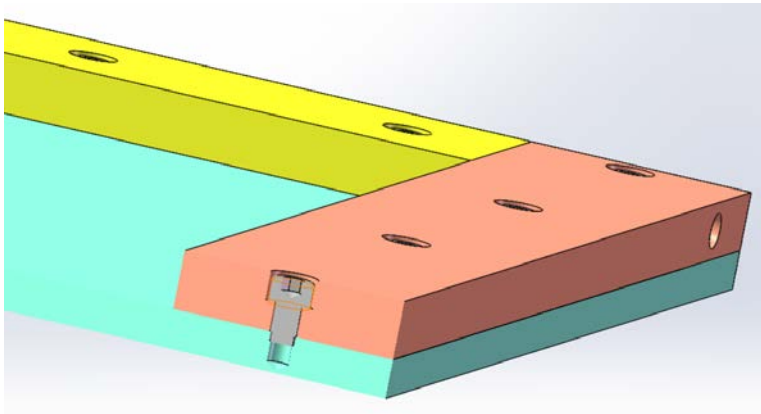
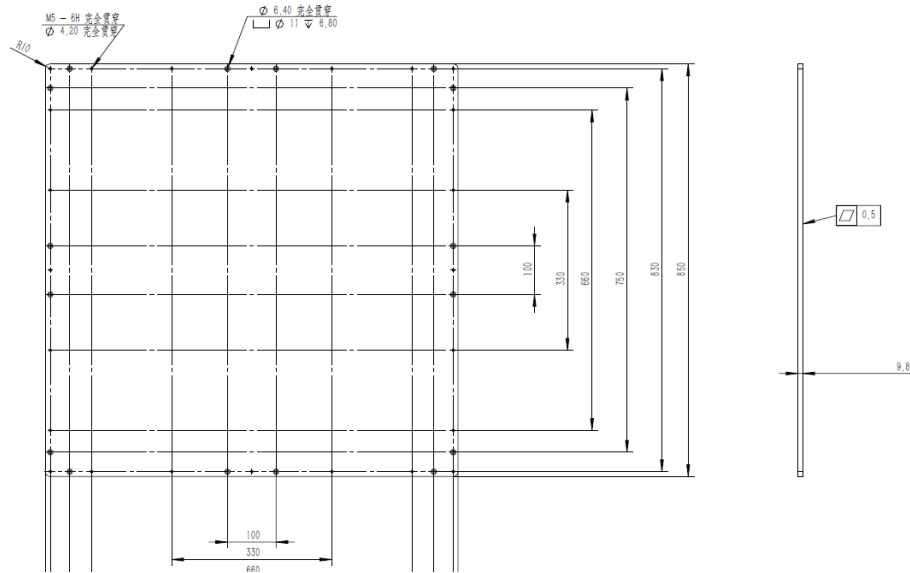

# Production of TPC module : Mesh improvements

- Impartments of mesh production:
  - Pre-tensioning of four stainless steel clamping bars completed; tension uniformity significantly improved.



# Production of TPC module : Mesh improvements

- Impartments of mesh production:
  - Tension stability has been improved — no variation in tension observed over a 6-hour period..
  - ~40kg tension in 2D



# Production of TPC module : Mesh improvements

- Impartments of mesh production:
  - After pillar etching and baking, the formation yield reaches 100%.
  - Microscopic observation and testing confirm excellent pillar formation quality.

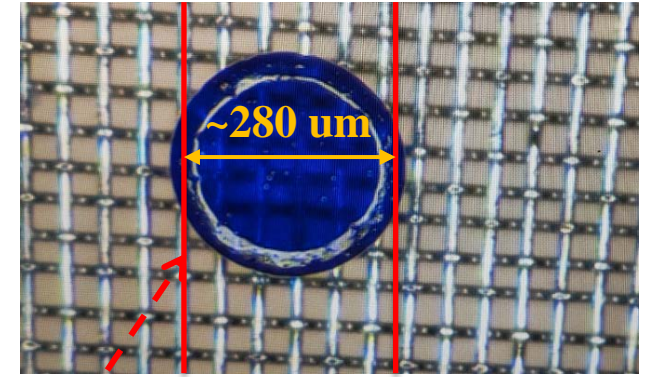
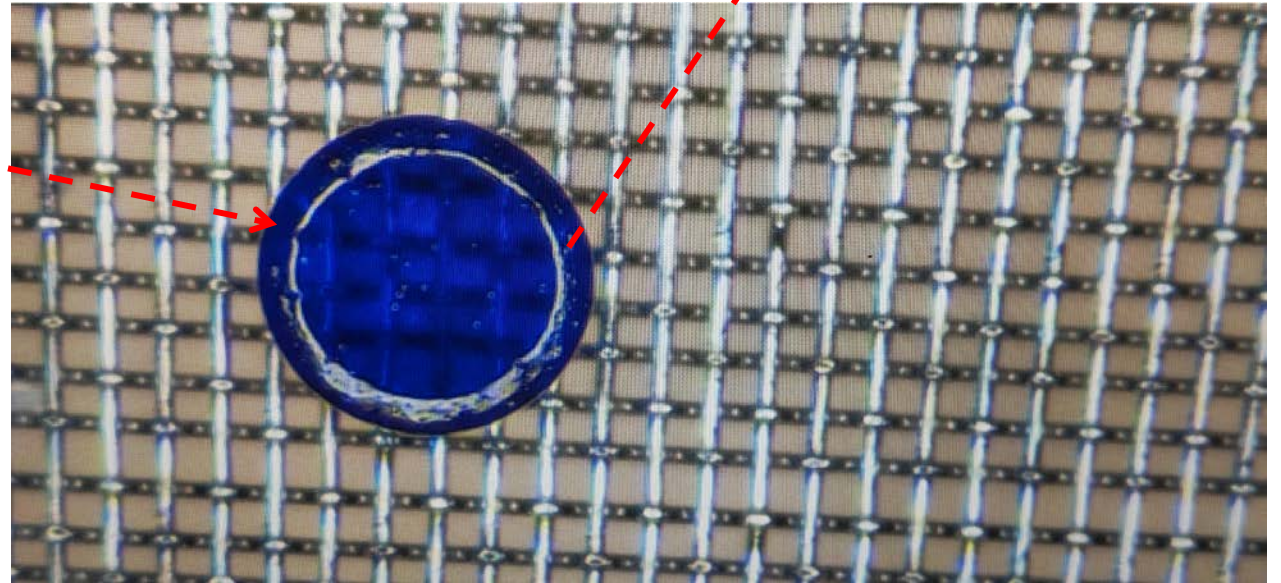
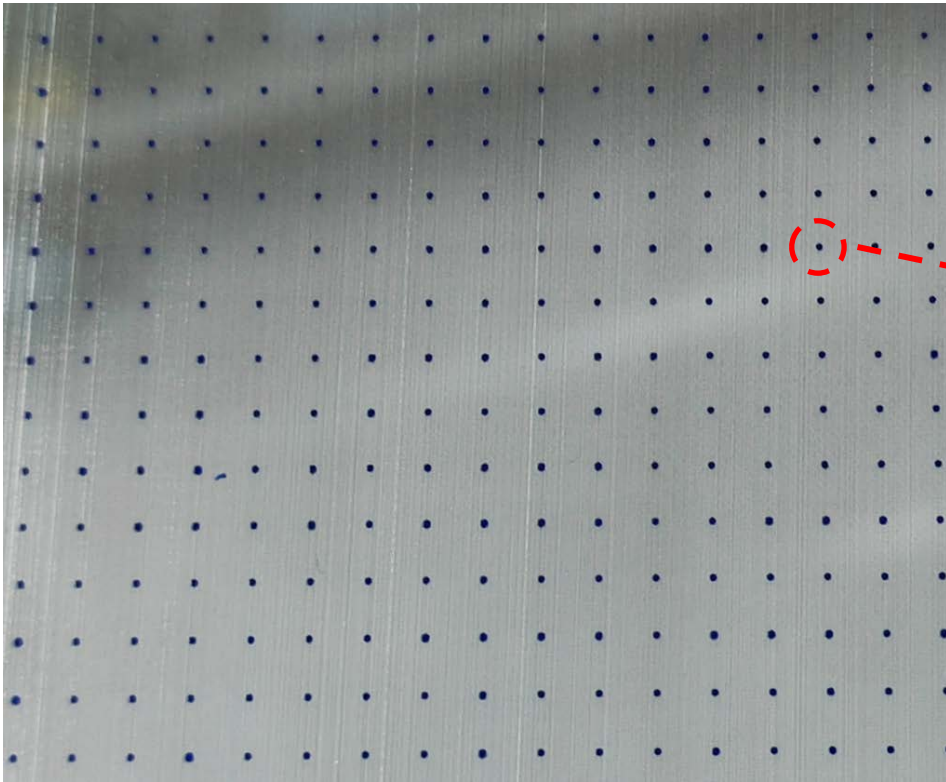

# High granularity readout: Production of TPC module

- Key issues to address
  - Stainless steel wire mesh stretching and rolling are optimization
  - **Improved detector gain**, resolution and overall performance

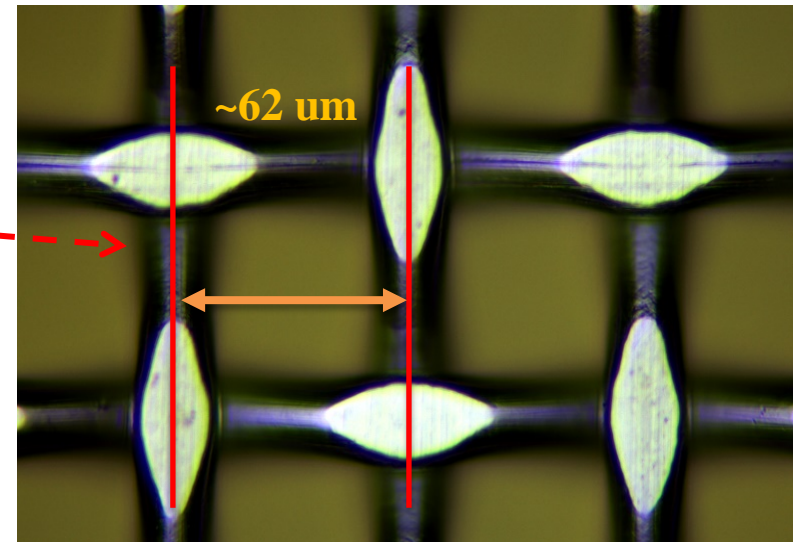
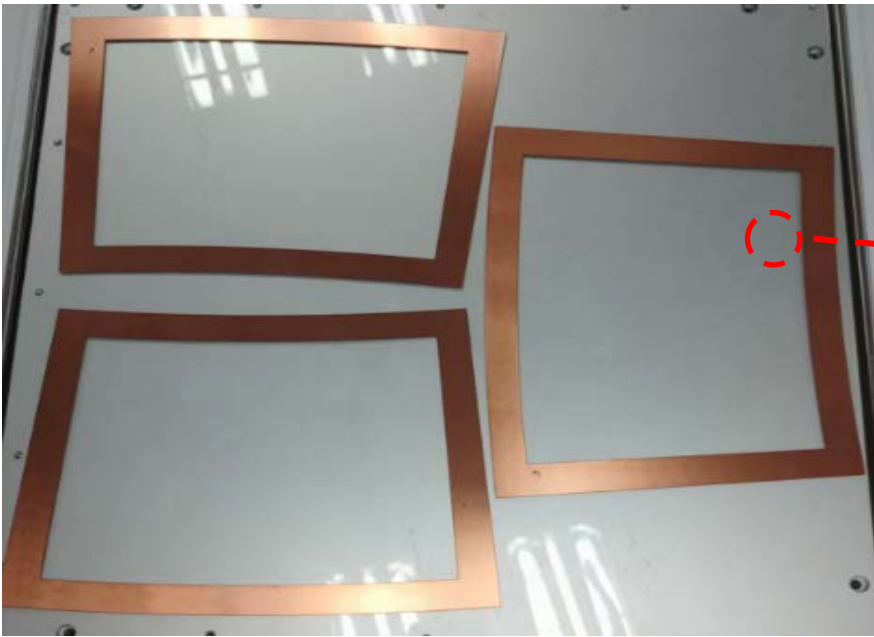

# Fe-55 spectrum of TPC module

- Achievement of TPC module:
  - Used Fe-55 source to acquire energy spectrum on mesh; energy spectra obtained through the small pixel readout and the two results are consistent.
  - Micromegas detector gain measured in T2K gas — good gain linearity achieved
  - TPC module with TEPIX v1 testing ongoing and validation

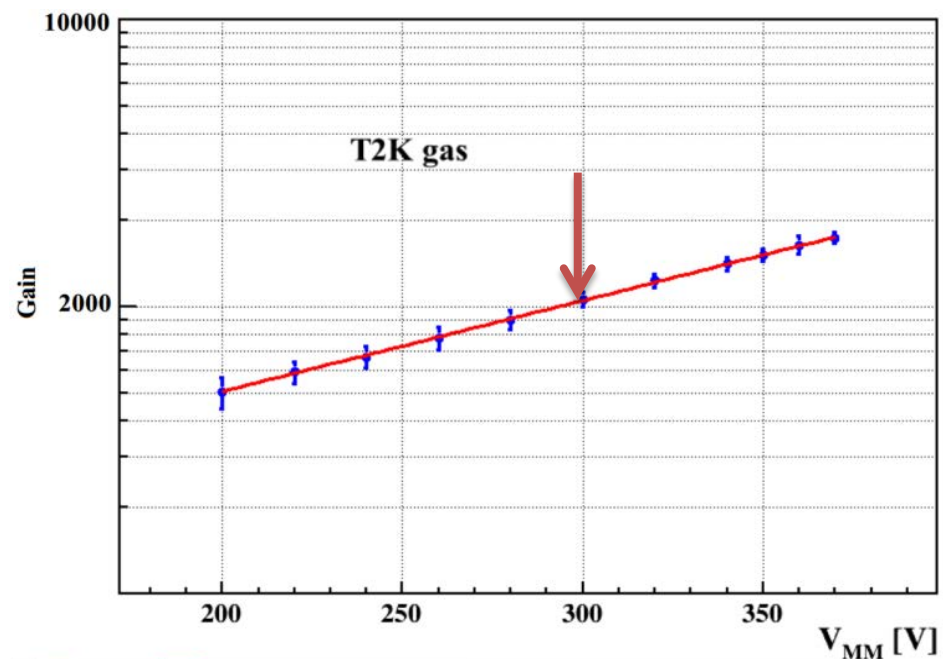
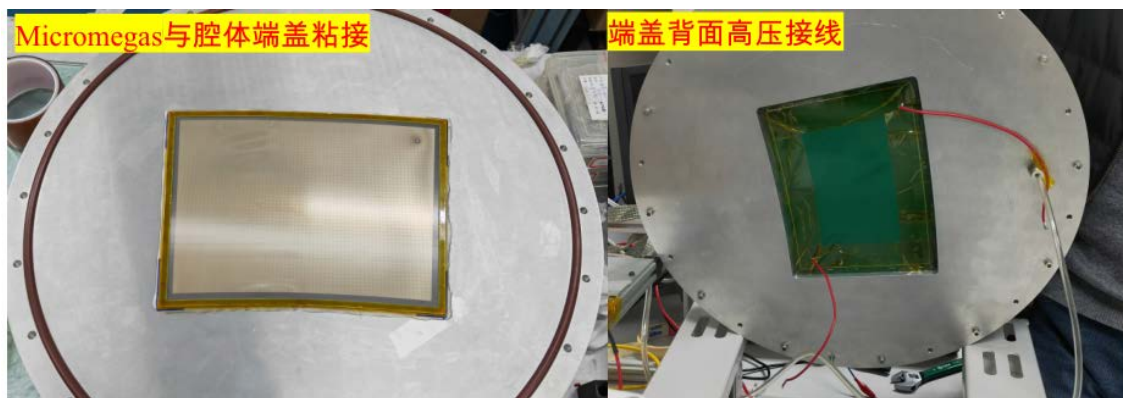
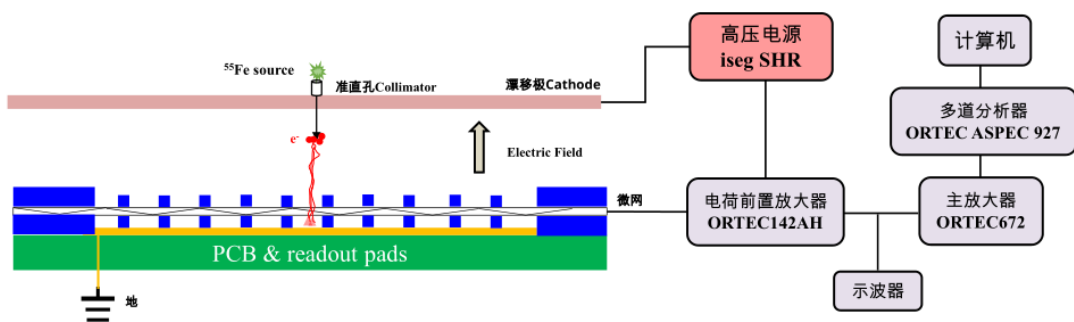

# Outstanding Issues in the Present Phase - I

- Gain instability has been observed in the finished products:
  - Microscopic inspection shows fine filamentary residues.
  - A compressed air cleaning system has been procured for integration into the mesh-stretching process to enhance yield.

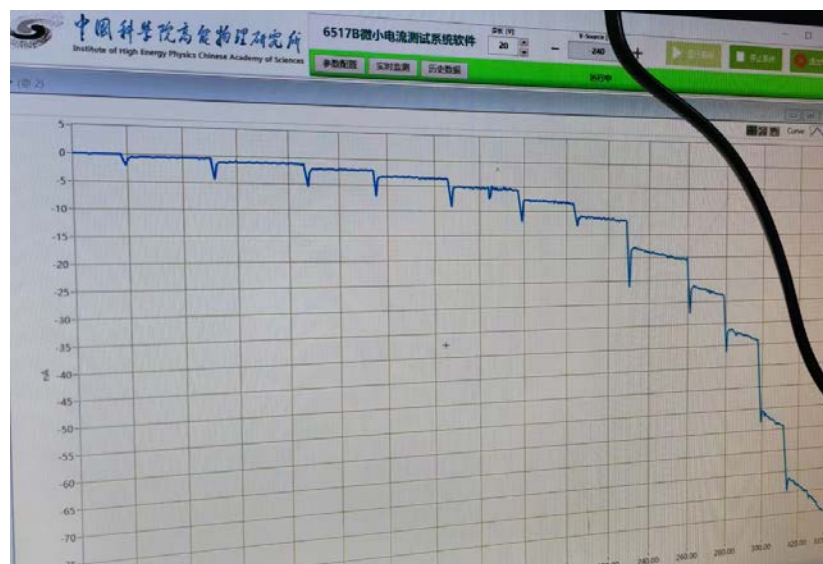
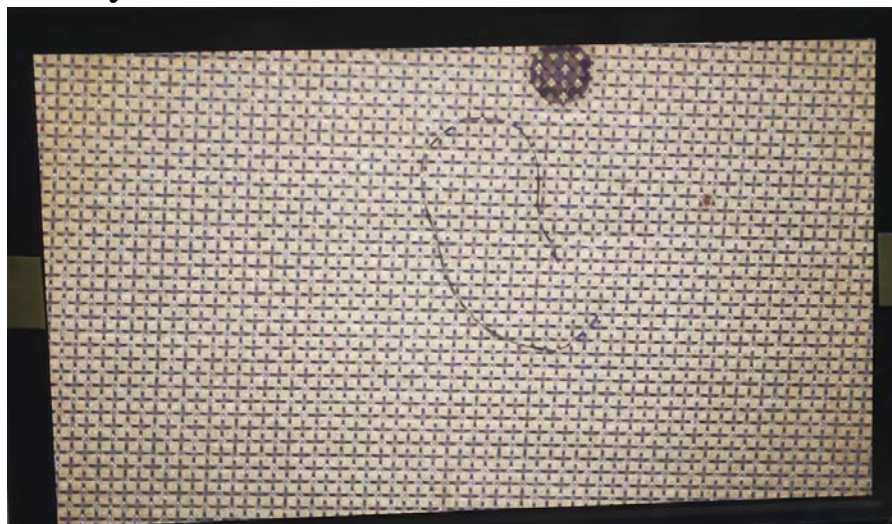

## Outstanding Issues in the Present Phase - II

- Gain instability has been observed in the finished products:
  - Assembly and testing of Micromegas detectors in various sizes
  - All prototypes demonstrated stable performance using T2K gas mixture in the lab

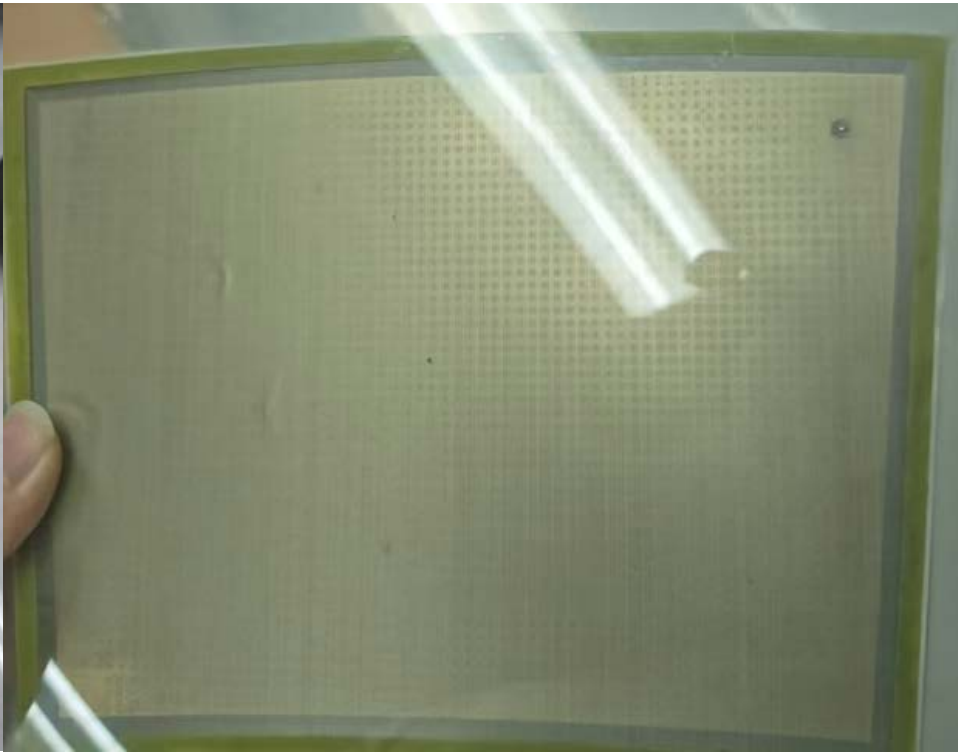

# Outstanding Issues in the Present Phase - III

- Gain instability has been observed in the finished products:
  - Current tests nominal — stable operation achieved at medium-to-high gain (<8000). Lower gain operation adopted with ample tuning margin.
  - Tsinghua collaboration confirmed (pending their graduation defense season). Team participants: Zhang Jinxian, She Xin, Zheng Jianbo. Detector configuration: 24 readout chips.

