



中国科学院高能物理研究所
Institute of High Energy Physics
Chinese Academy of Sciences

APES Development: Progress Report & Current Status

Tianmu Xin

On behalf of the APES team

April 15, 2026, CEPC Day.

Outline

- Motivation
- Design philosophy
- Modeling and Optics
- Tracking and Simulation
- Summary

Team

- No full-time staff
- One full-time postdoc (July. 2024-June.2026)
- Strong support from K. Ohmi, E. Forest, K. Oide and D. Zhou
- Weekly meeting for more than 3 Years.

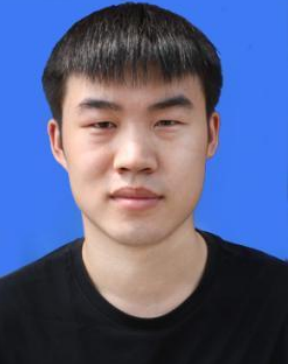
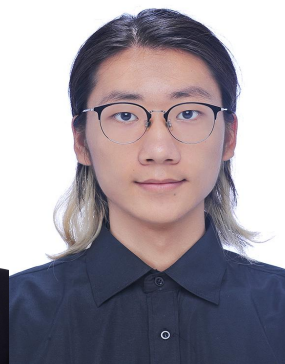
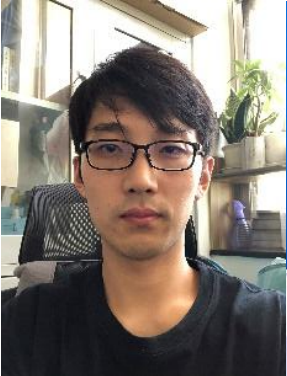

Motivation

Supported by IHEP Innovation Fund
from 2022 to 2024

To meet the requirements of beam dynamics studies for CEPC

- Modeling complicated lattice more easily
 - IR, overlapped field, ...
- Combined effects should be studied self-consistently
 - Beam-beam interaction + impedance/feedback/lattice, ...
- Use of new hardwares
 - CPU, Openmp/MPI -> GPU, CUDA

More user-friendly, more accurate, more straightforward, and faster

Design philosophy

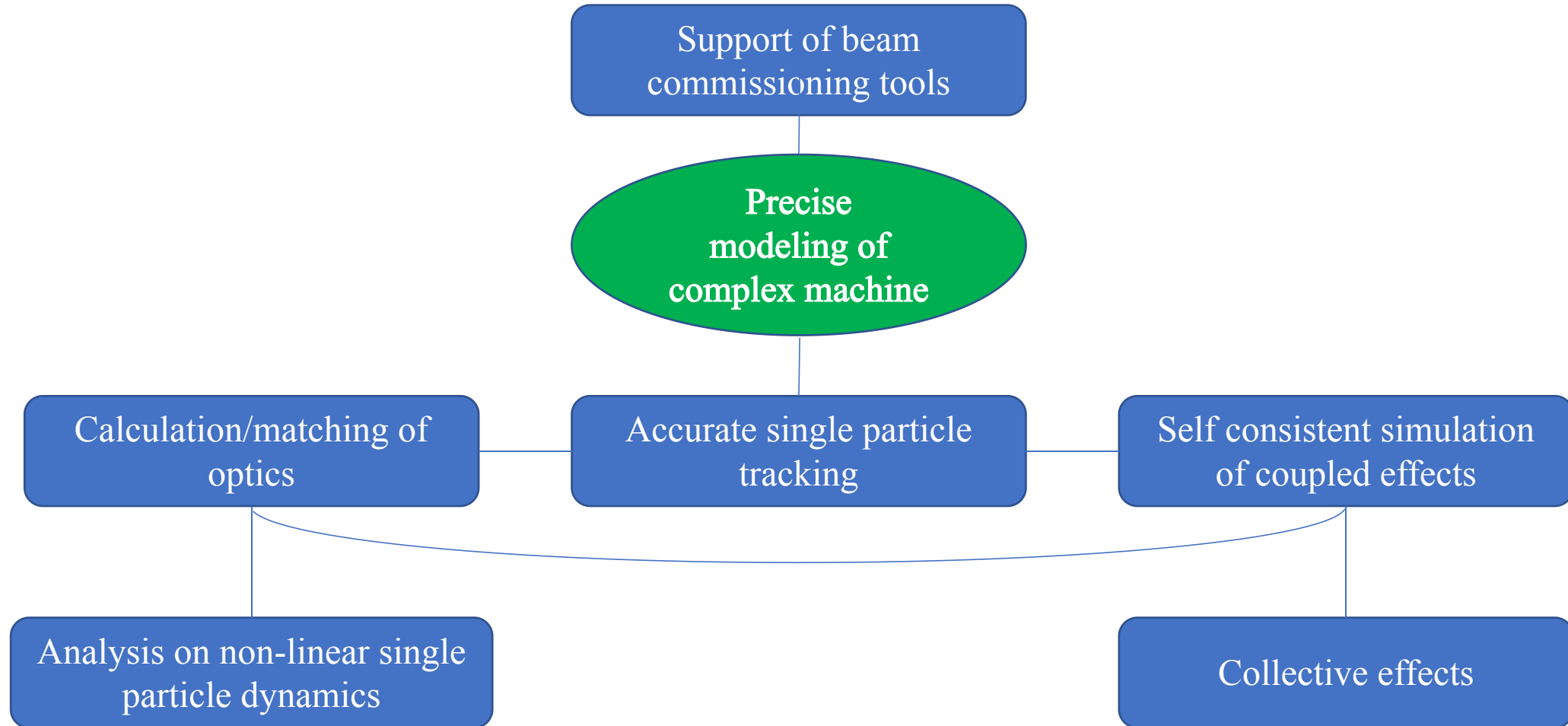

Design philosophy

- Python, C/C++
- Bottom-up and top-down synchronized development
 - Python-based modeling, analysis, computation logistic
 - High-efficiency parallel computing for multi-bunch Multi-Particle Tracking
 - Same underlying map

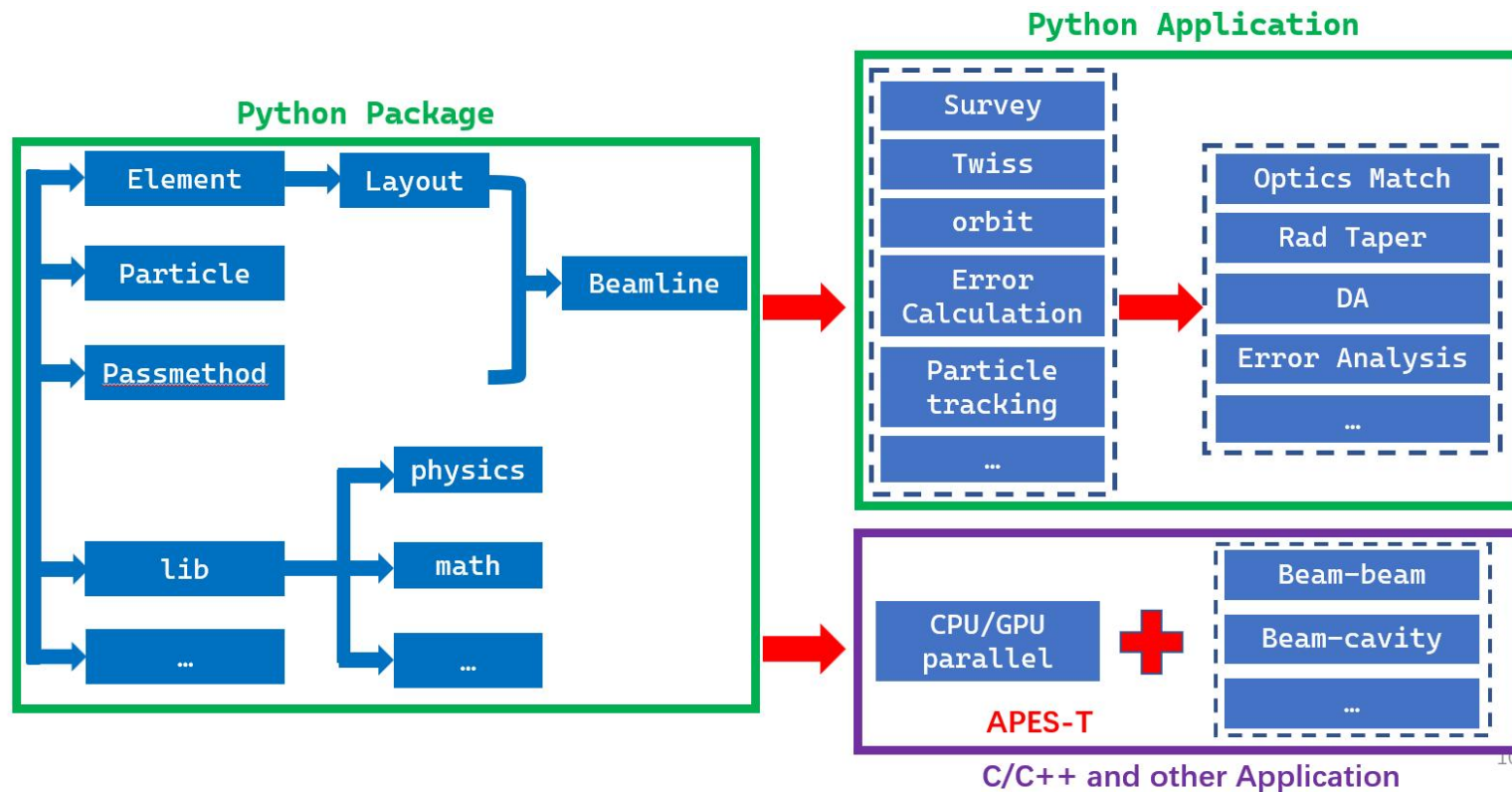

Design philosophy

Multi-particle tracking

- Focus on High-performance simulation
- Tracking through simple elements in parallel on multi-CPU
- Tracking through special elements on GPU:
 - Strong-strong beam-beam interaction
 - Feedback
 - Collective effects
 - Short-range Wakefield
 - Space Charge (Ohmi)
 - Beam-Cavity
 - Electron Cloud
 - Ion effects
 - Intra-beam Scattering
 - ...
- CUDA+MPI

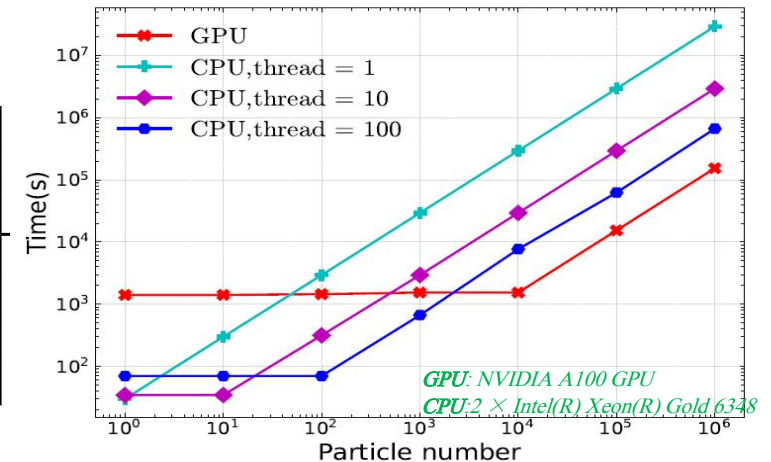
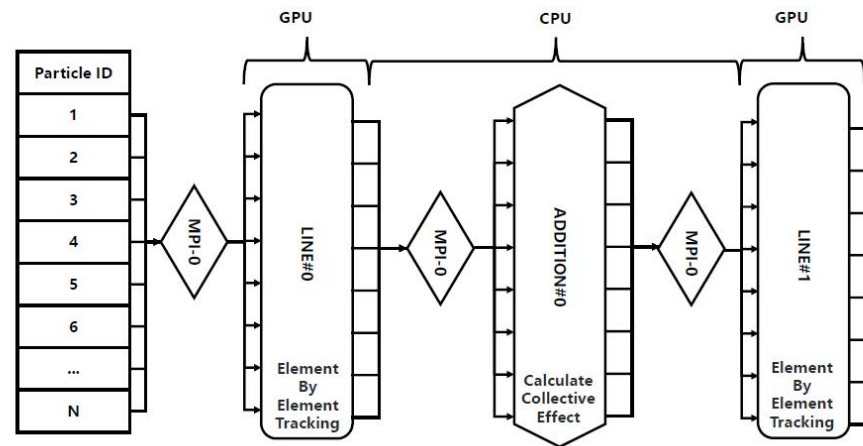
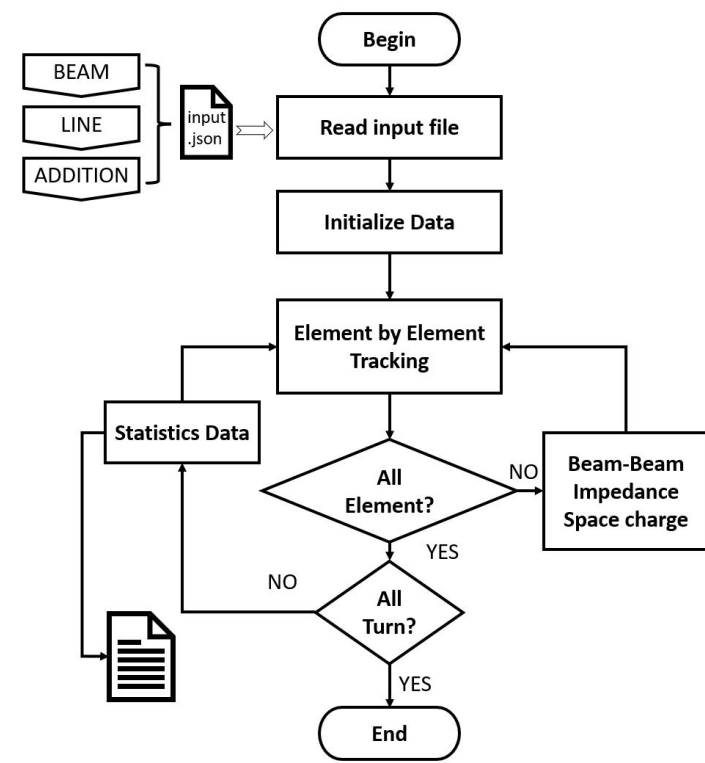

Design philosophy

The idea of **Patch** comes from PTC

- Affine transformation in geometry
- Maps in particle tracking
- Single “Patch” affects the downstream survey.
- Allows special installation and misalignment studies

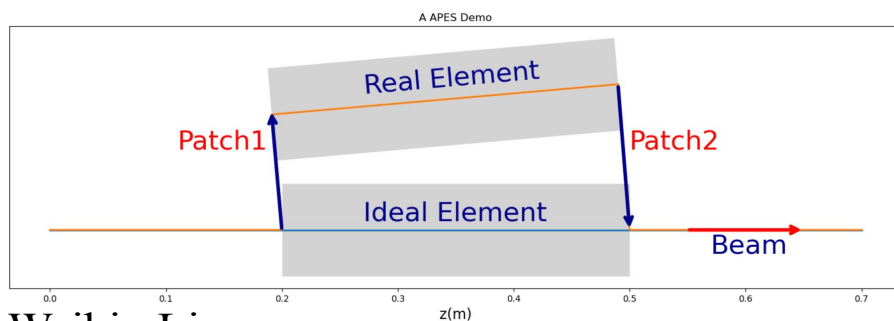
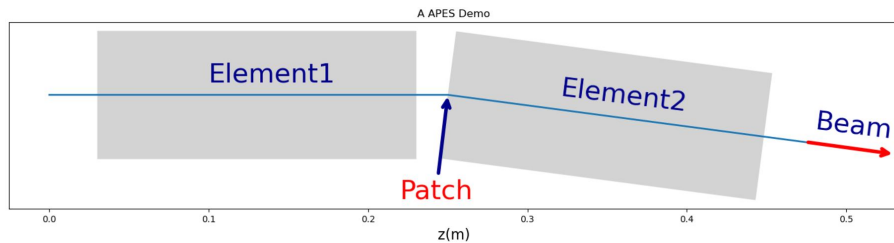

A ring with only
Quadrupoles

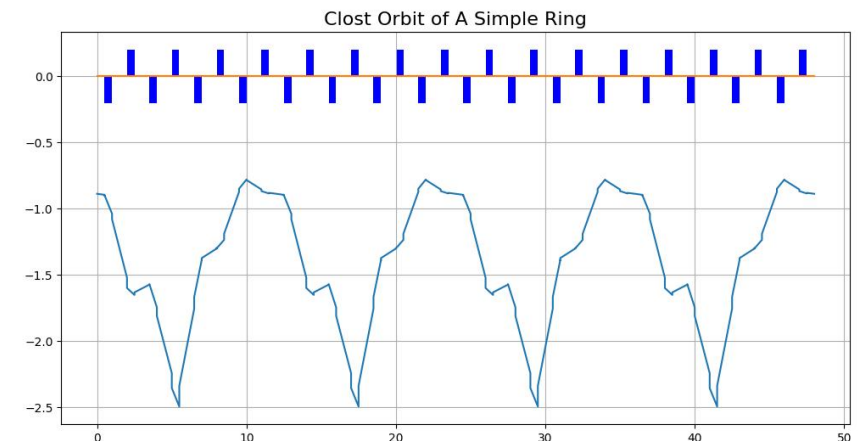
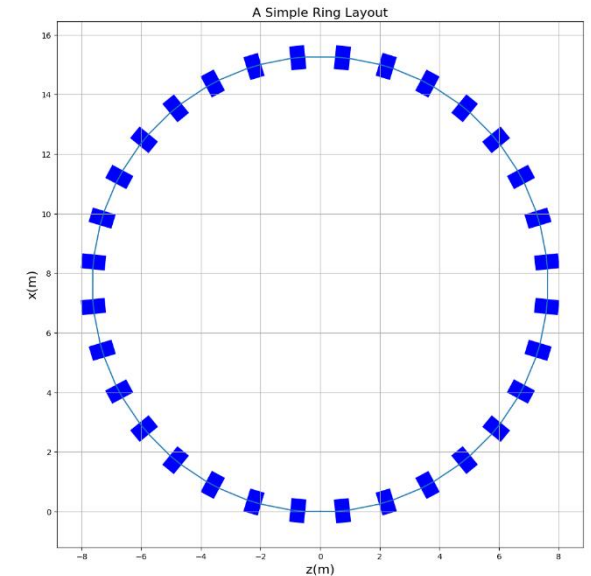

Design philosophy

- Encapsulate one or more components
- Ensemble positional error for co-mounted components
- Different beams can go through same component
- Forward or backward traversal

Element Container

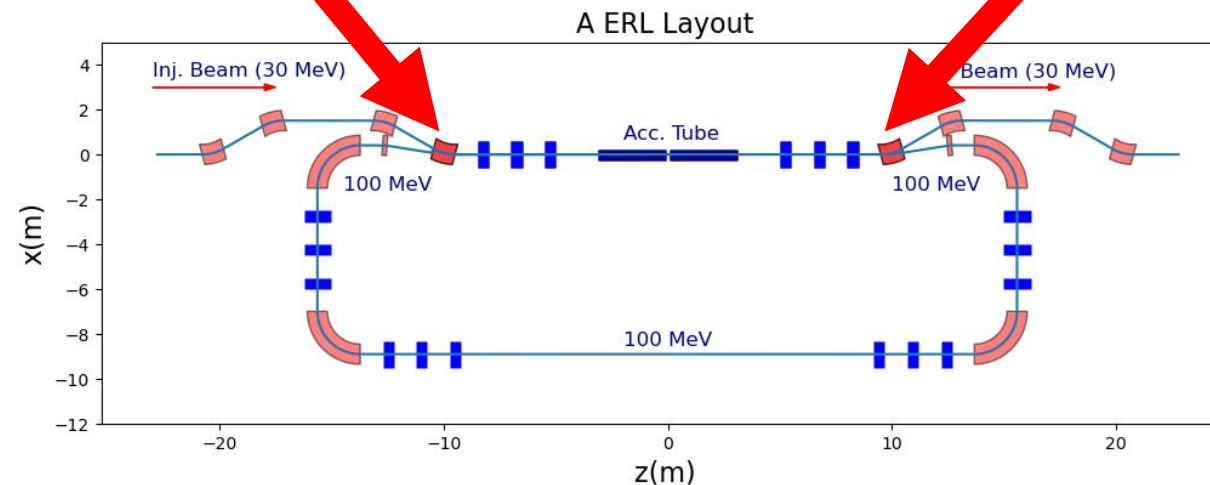
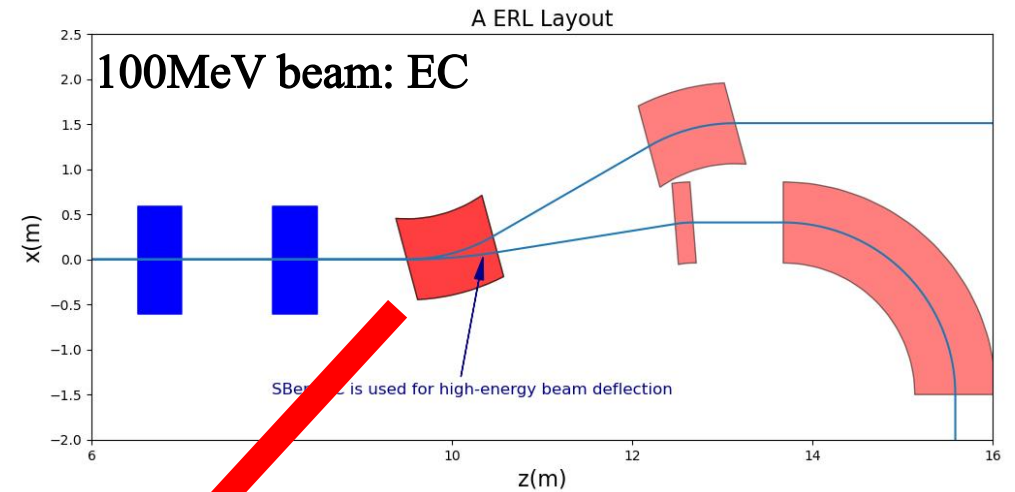
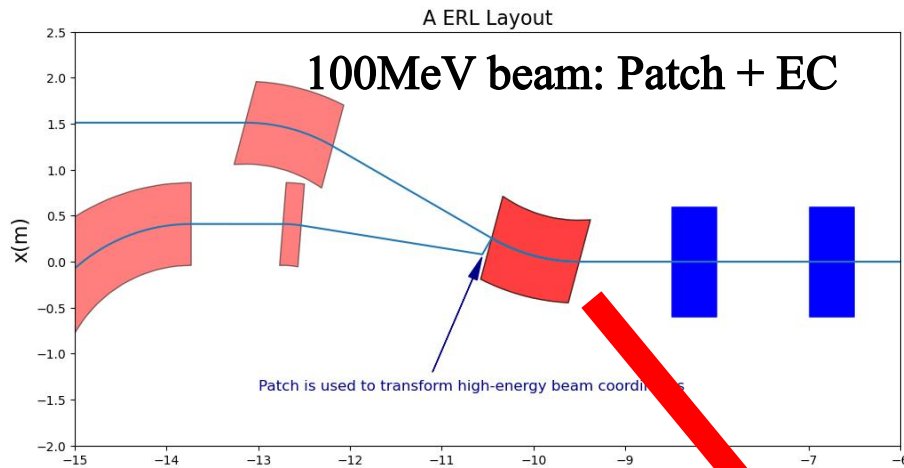

Modeling and optics

IR modeling of BEPCII

Patch1+SCQ+Patch2

BPR4IR = [IP, D4I01, R4CBPM00, D4I01P, P_SCQ_4II, SCQE, P_SCQ_4IO]

BER4IR = [P_SCQ_R400, SCQE, P_SCQ_R40I, D4001P, R4CBPM00, D4001, IP]

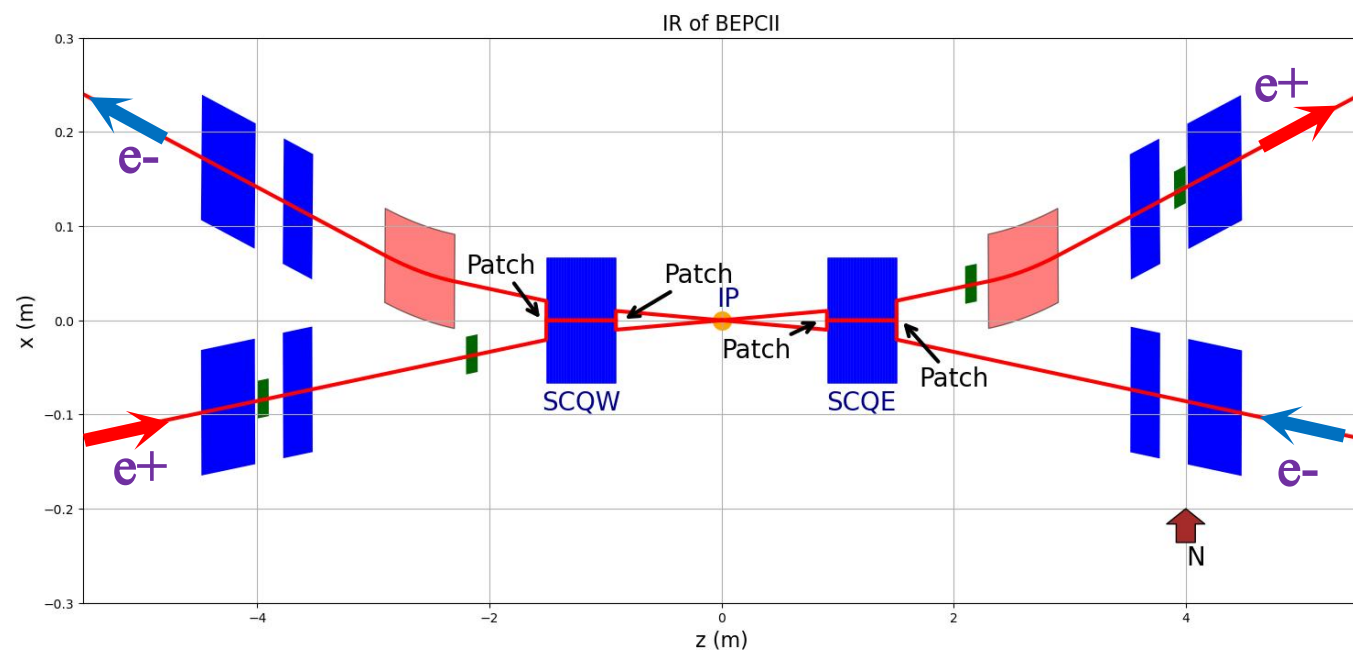
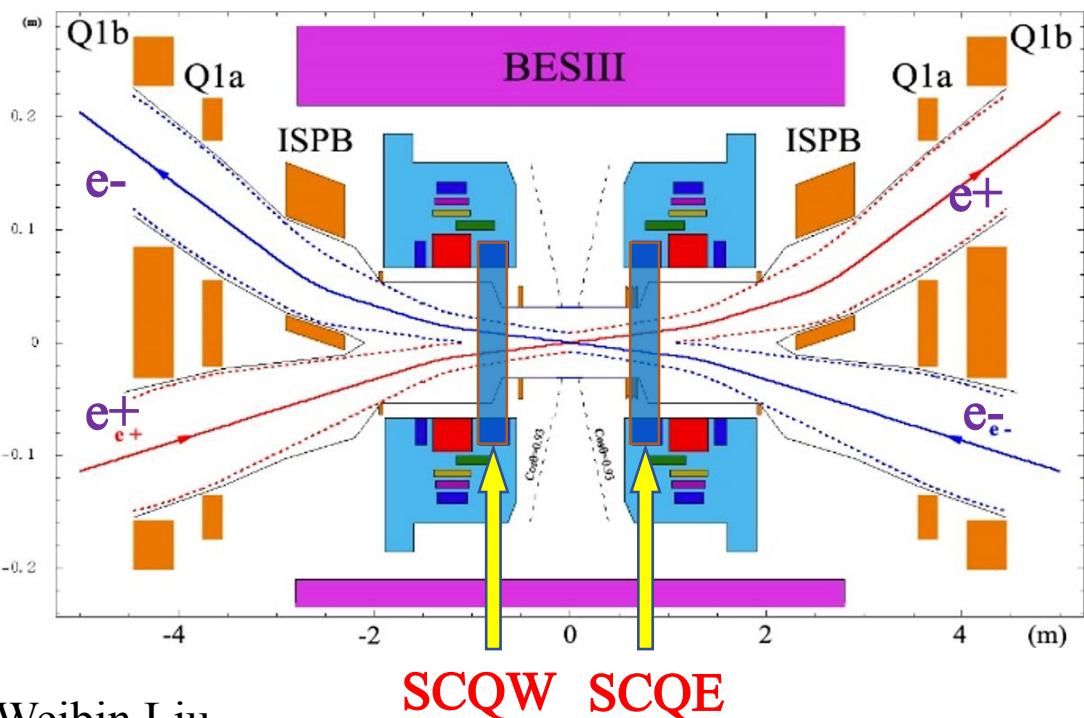

Modeling and optics

Transfer Map benchmarked against SAD

- 6D full-symplectic tracking
- Linear soft edge + nonlinear Maxwellian fringe
- Field overlap of solenoid and multipoles

Benchmark of single particle tracking with SuperKEKB

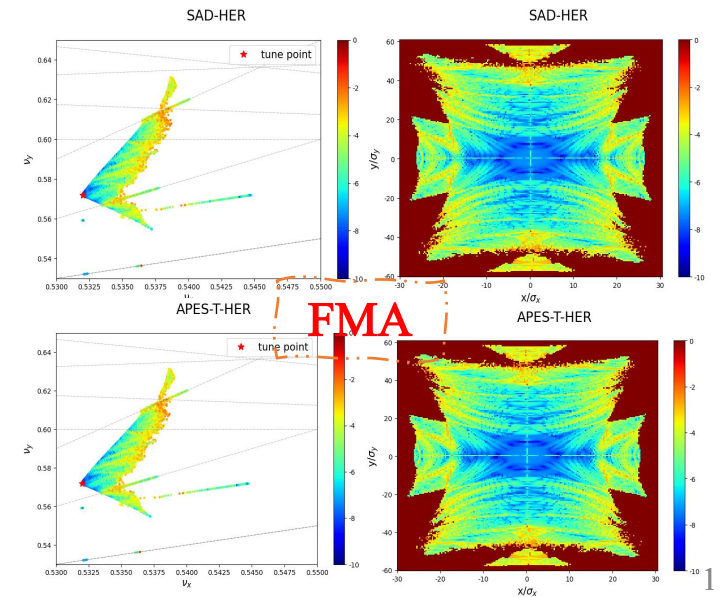
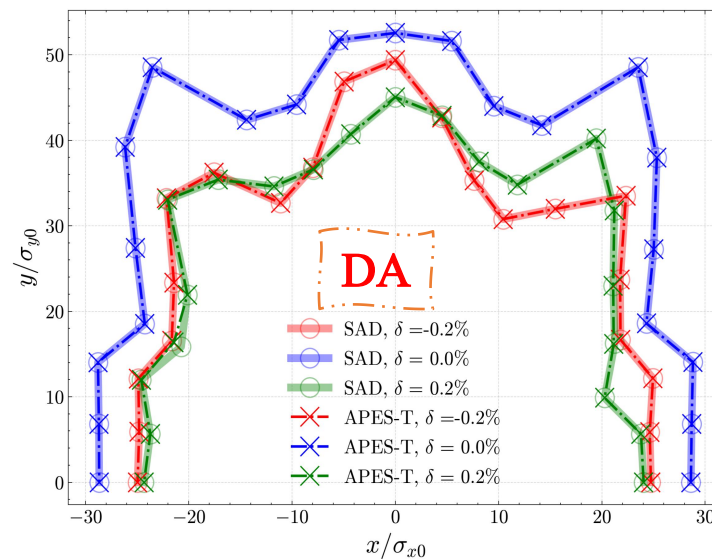
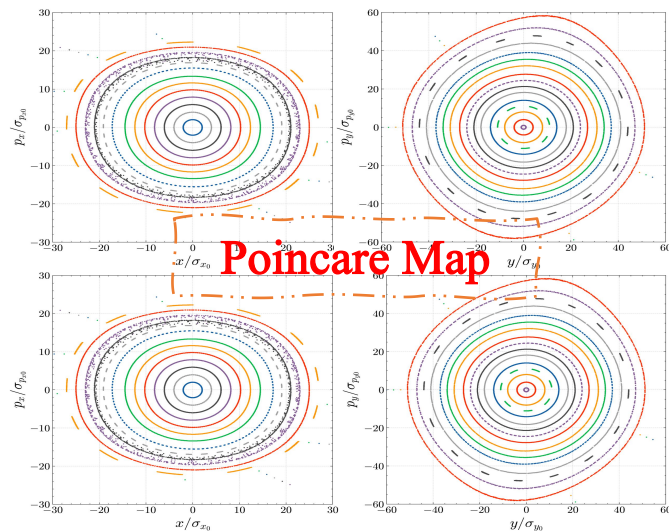

Modeling and optics

Implementation of Surface Method

- Exact modeling of multipoles and fringe field
- Inverse Laplacian kernels help reducing the field noise
- Implicit symplectic integrator

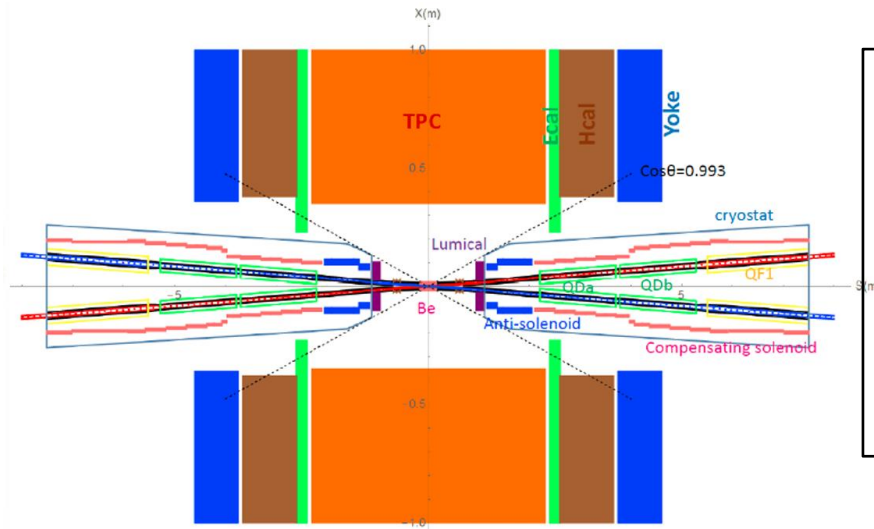
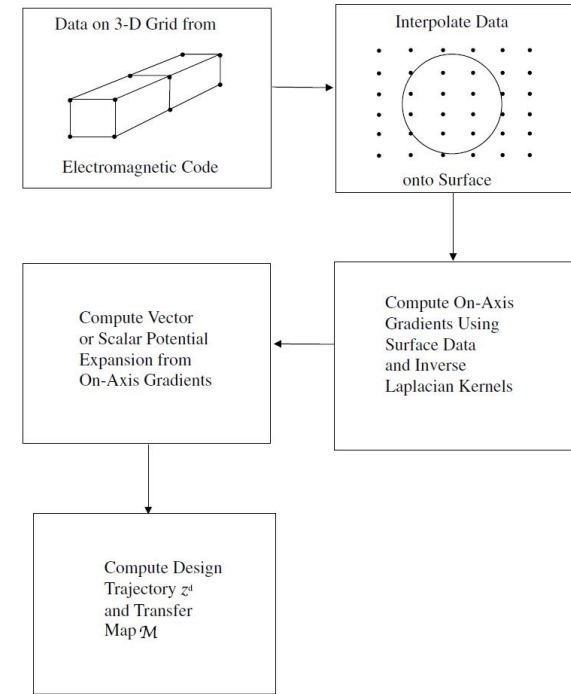

- Final focus region of CEPC
 - 6 dual-aperture SC quad
 - 3 T detector solenoid
 - Anti-solenoid
 - Dipole corrector and skewQ

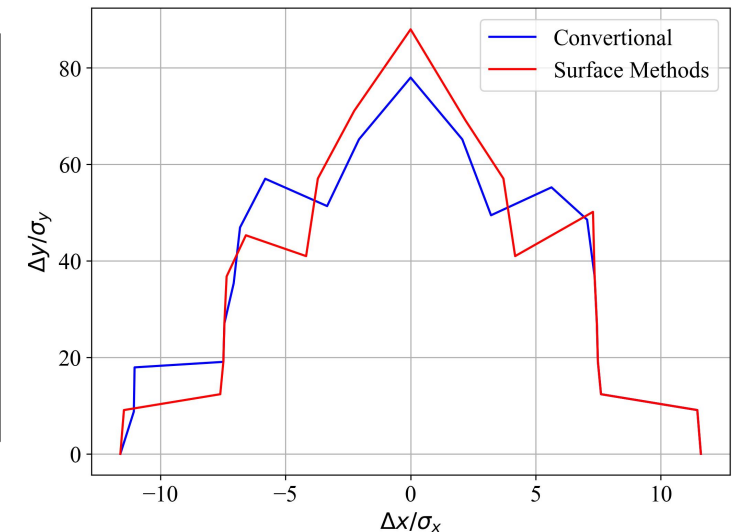

Modeling and optics

4D,5D and 6D with SR damping

Optics functions

- General Twiss function
 - Closed orbit
 - Jacobian matrix
 - Linear normal-form Analysis

$$\Sigma = \sum_{I,II,III} B^K \epsilon_K \quad \begin{aligned} \beta_x &= B_{11}^I, & \beta_y &= B_{33}^{II} \\ \alpha_x &= -B_{12}^I, & \alpha_y &= -B_{34}^{II} \\ \gamma_x &= B_{22}^I, & \gamma_y &= B_{44}^{II} \end{aligned}$$

$$\mathbf{x} = \mathbf{x}_0 + D\delta + D^z z \quad D = \frac{\partial}{\partial \langle \delta \rangle_C} \langle \mathbf{x} \rangle_C$$

$$\langle \mathbf{x} \rangle_C = \langle \mathbf{x}_0 \rangle_C + D \langle \delta \rangle_C + D^z \langle z \rangle_C \quad D^z = \frac{\partial}{\partial \langle z \rangle_C} \langle \mathbf{x} \rangle_C$$

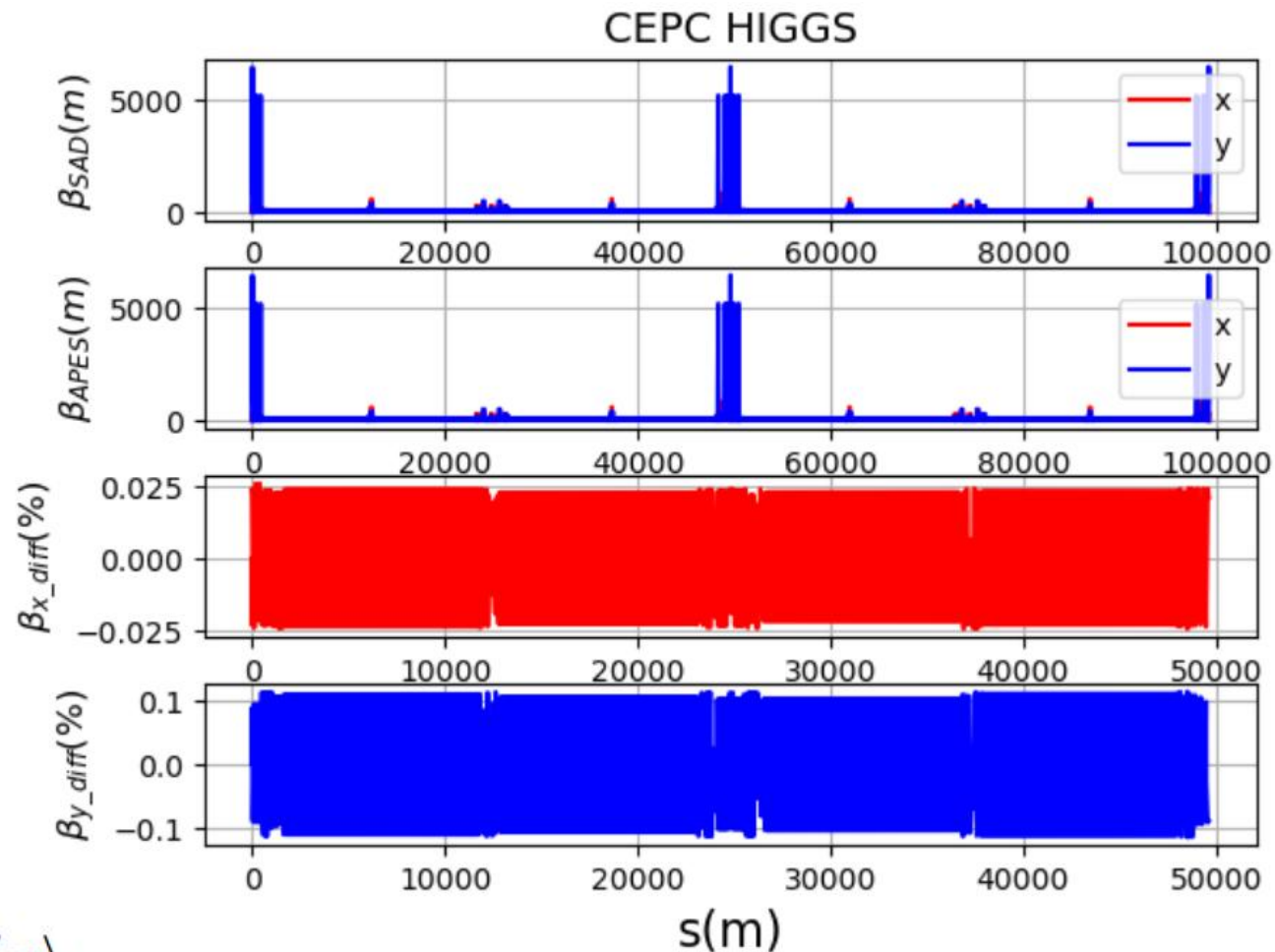

Difference from SAD $\sim 0.1\%$

Modeling and optics

- Energy deviation along the ring
- Magnet tapering mitigate the orbit distortion
- Selective magnet tapering is possible

Synchrotron Radiation and tapering

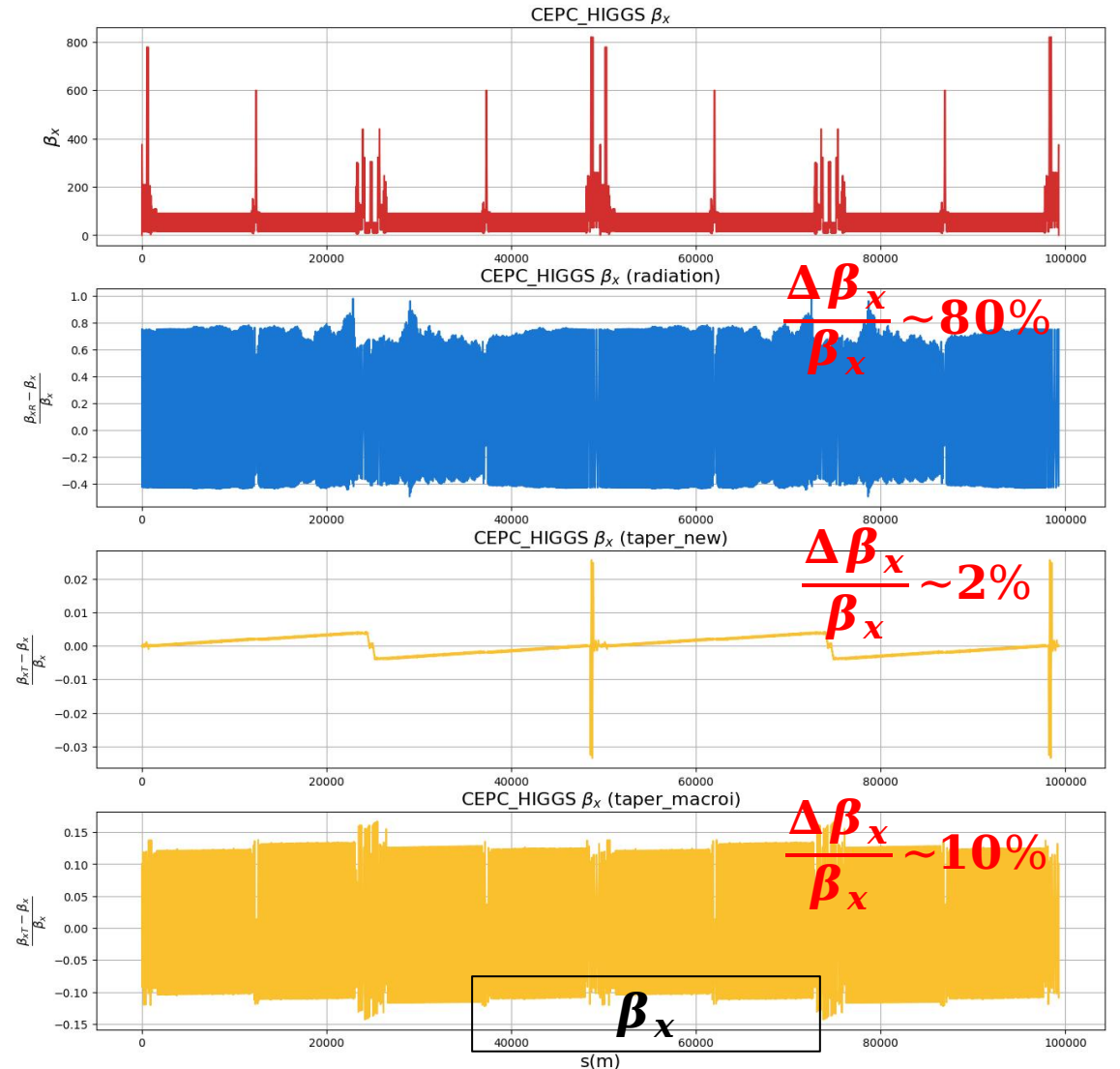
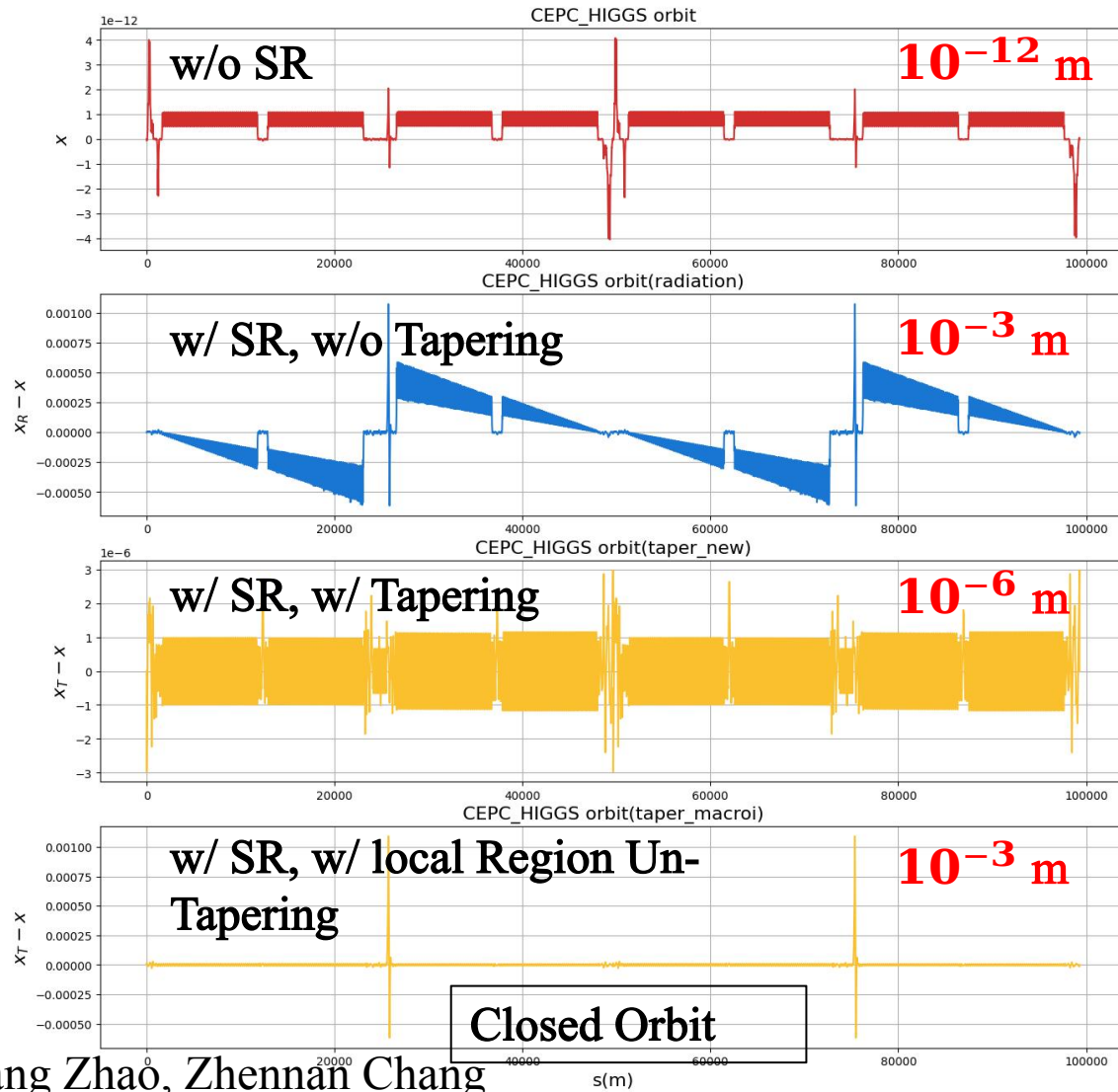

Modeling and optics

Emittance

- Ohmi's envelope method

$$\Sigma = M \Sigma M^T + \bar{B}$$

Equivalence matrix at s

One-turn Matrix

Quantum Excitation (Diffusion Matrix)

$$\bar{B} = \int_{s_0}^s M(s, s') B(s') M^T(s, s') ds'$$

Transfer matrix from s' to s.

Quantum excitation at s'

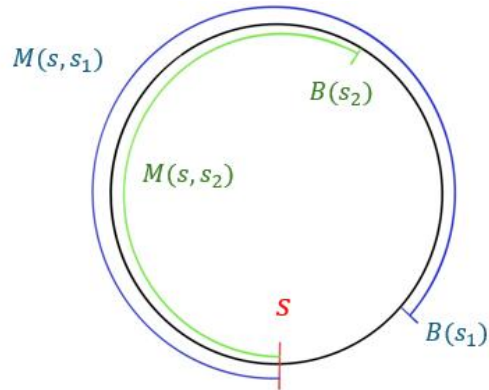

$$\bar{B} = M(s, s_1) B(s_1) M^T(s, s_1) + M(s, s_2) B(s_2) M^T(s, s_2) + \dots$$

HEPS	Elegant	APES	Difference
Damping in x	4.178e-4	4.187e-4	0.23%
Damping in y	2.201e-4	2.199e-4	~0
Damping in z	2.424e-4	2.412e-4	0.52%
Emittance x	3.482e-11	3.479e-11	0.096%
Energy spread	1.018e-3	1.020e-3	0.20%

CEPC HIGGS	SAD	APES	Difference
Damping in x	7.523e-3	7.550e-3	0.37%
Damping in y	7.523e-3	7.550e-3	0.36%
Damping in z	1.488e-2	1.510e-2	1.49%
Emittance x	6.648e-10	6.646e-10	0.029%
Energy spread	1.013e-3	1.013e-3	0.003%

Modeling and optics

Modeling LER and HER of SuperKEKB in APES

APES coordinate system

(x,y,s)- RHS

- Survey always represents the actual position of components
- 'patch' is introduced to represent the misalignment and displaced installation,

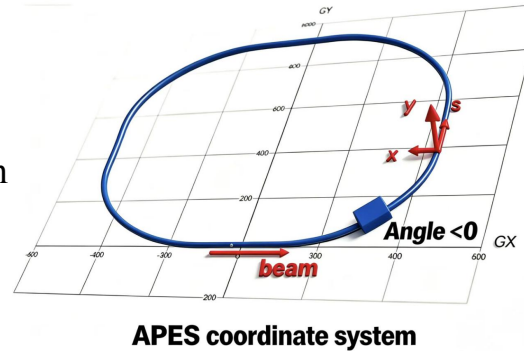

Solenoid modeling (Transfer map referring to SAD)

- No BOUND defined, components in solenoid have "Insol" flag
- Interleaved components with field data from SAD
- Solenoid data from field maps with magnetic field expansion on beam pipes (the same as SAD)
- Use patches to perform the coordinate transformation and calibrate the survey to SAD's at the boundary of solenoid

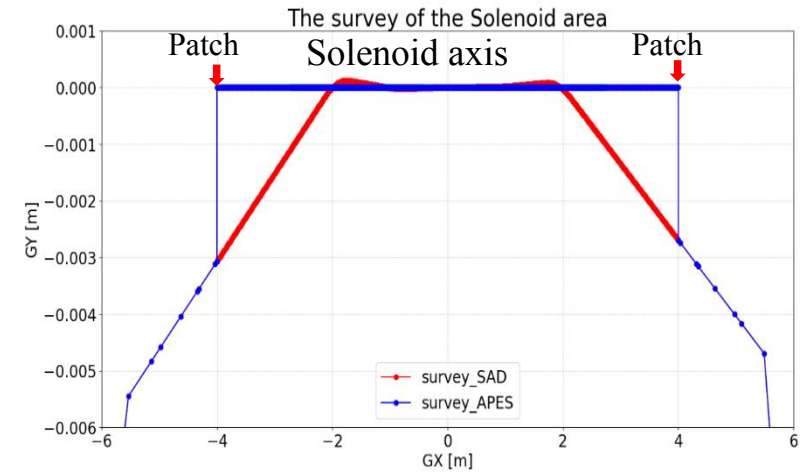
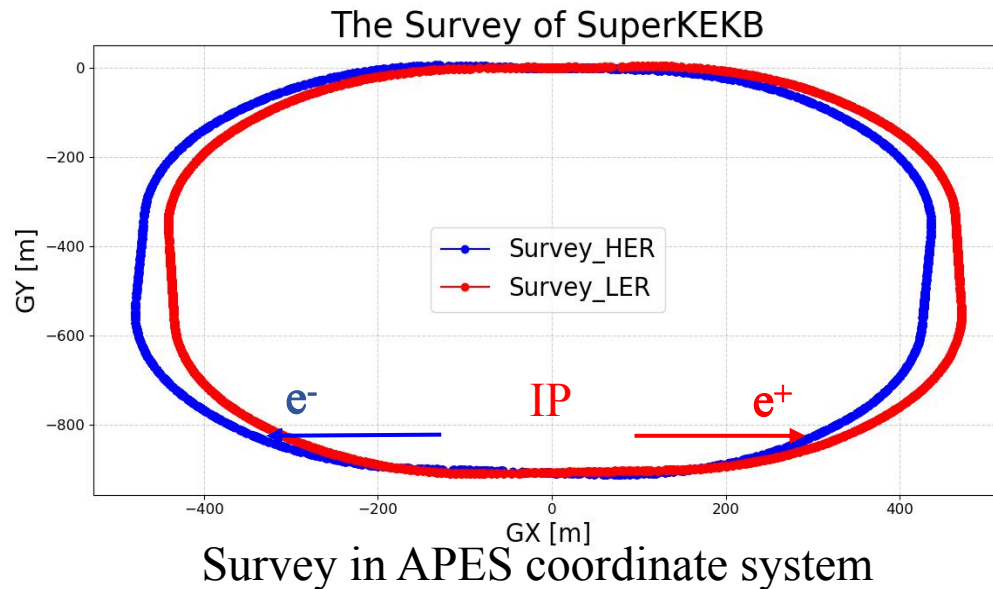

Modeling and optics

Modeling LER and HER of SuperKEKB in APES

- Agrees well with SAD.
- Beta beating (4D) smaller than 0.1% except some deviation due to nominal values close to zeros near IP
- The 6D twiss calculation has also completed

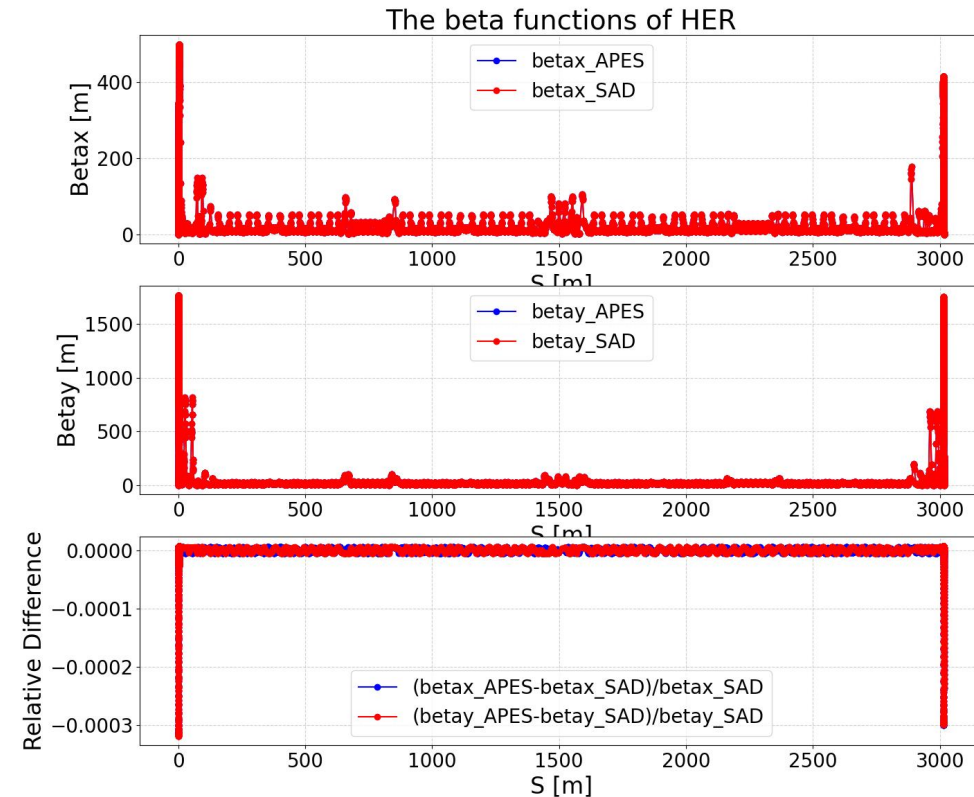
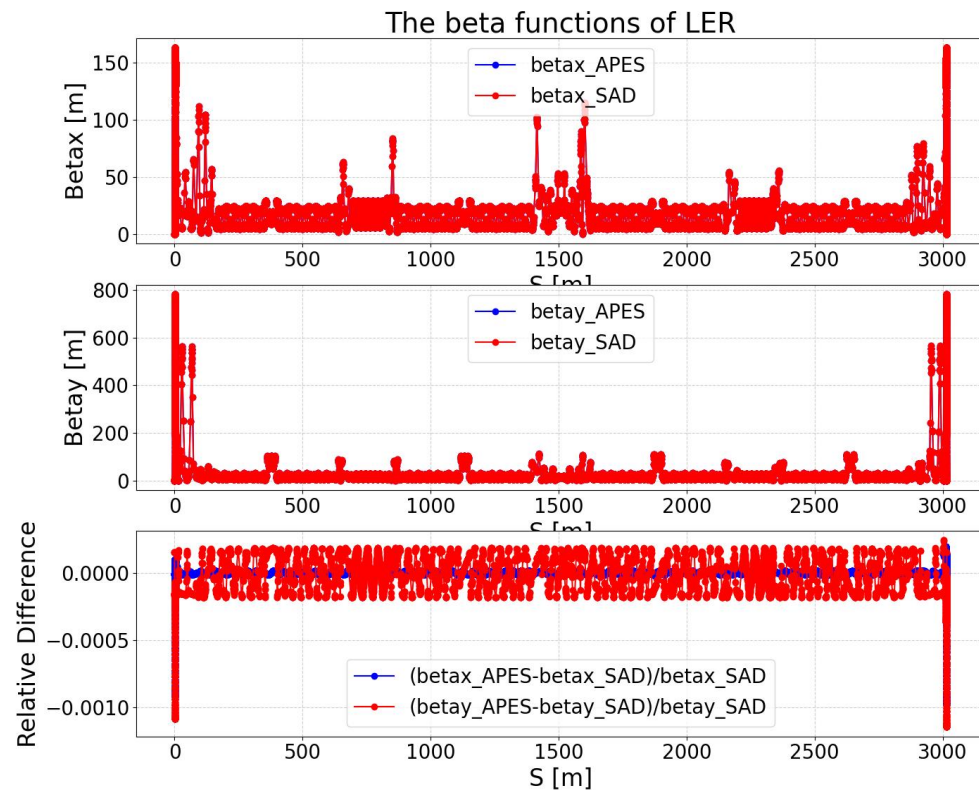

Modeling and optics

Modeling LER and HER of SuperKEKB in APES

	SAD HER	APES HER	Δ/SAD [%] HER	SAD LER	APES LER	Δ/SAD [%] LER	unit
emit.X	4.462	4.305	3.519	4.014	4.500	12.108	nm
emit.Y	0.567	0.561	1.058	0.290	0.435	50.000	pm
emit.Z	3.18	3.317	4.308	3.462	3.922	13.287	um
damping Rate.X	1.735	1.833	5.648	2.203	2.601	18.066	E-4
damping Rate.Y	1.737	1.786	2.821	2.203	2.598	17.930	E-4
damping Rate.Z	3.475	3.517	1.209	4.404	5.255	19.323	E-4
energy spread	6.303	6.438	2.142	7.525	7.994	6.233	E-4
bunch length	5.047	5.157	2.18	4.600	4.906	6.652	mm
Tune x	45.5320	45.5315	0.001	44.5240	44.5248	0.002	
Tune y	43.5720	43.5715	0.001	46.5890	46.5902	0.003	
Mom. compac	4.543	4.538	0.11	2.9697	2.9691	0.020	E-4

Modeling and optics

Modeling HEPS in APES

We've tried to build the lattice in three different approaches

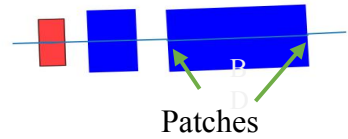

Parameter	elegant	APES (BEND)	APES (Off-center Quad)	APES (multipole including crosstalk)
Circumfrence	1360.3999680	1360.39996800	1360.399810093565	1360.399901373
Emittance	34.82pm	34.76pm	35.36pm(60片)	36.274pm
Chromaticity (H.)	4.951	5.088	5.172	8.5198
Chromaticity(V.)	5.003	5.014	2.036	17.3554
eta	1.8385e-5	1.8385e-5	1.8385e-5	1.8385e-5
RF frequency	166600340	166600340	166600360	166600348
taux	1.086040e-2	1.085991e-2	1.069537e-2	1.074120e-2
tauy	2.061681e-2	2.061680e-2	2.057760e-2	2.038226e-2
taudelta	1.871444e-2	1.865961e-2	1.902375e-2	1.792877e-2
Tunex	115.1519	115.1520	115.0178	115.26699
Tuney	104.2912	104.2905	105.3722	104.62627

Modeling and optics

Weibin Liu, Yuan Zhang, Dou Wang

Modeling Combined magnets in CEPC with APES

□ **Mini-review recommendation:** The combined magnet is modeled using ANG and K2 in SAD, but reviewers recommend transitioning to K0 and K2 in a Cartesian coordinate system for more realistic simulations.

- APES: Accelerator Physics Emulation System
- Particles trajectory is curved.
- The sext. center is a line along the center of the dipole.
- The off-center trajectory will introduce extra quadrupole field and beta oscillation.
- The position of sext. center is optimized with zero integrated quatrupole field.

Closed orbit in the combined dipole

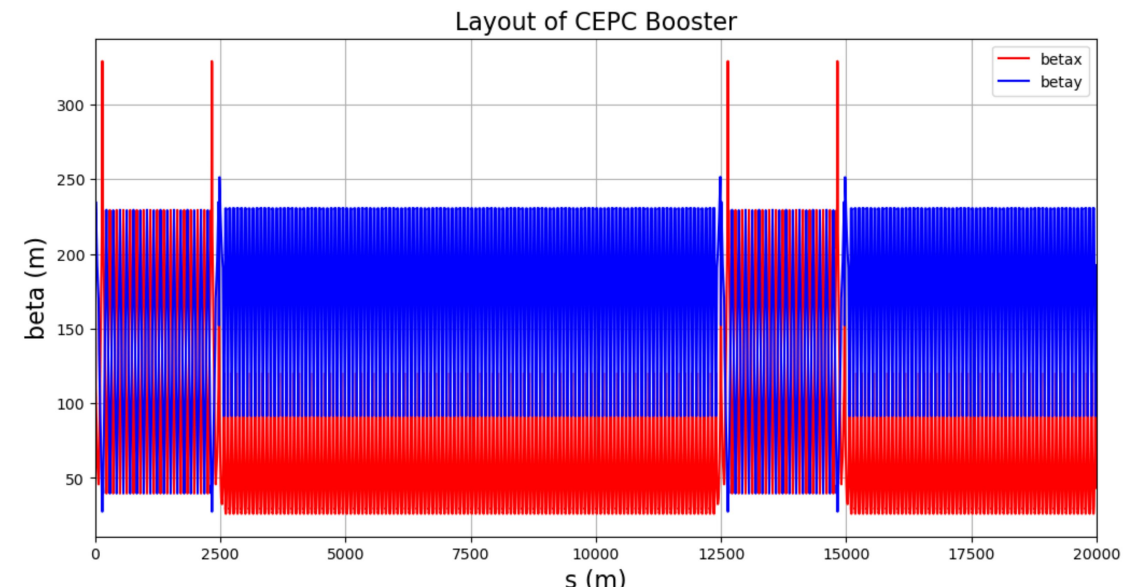
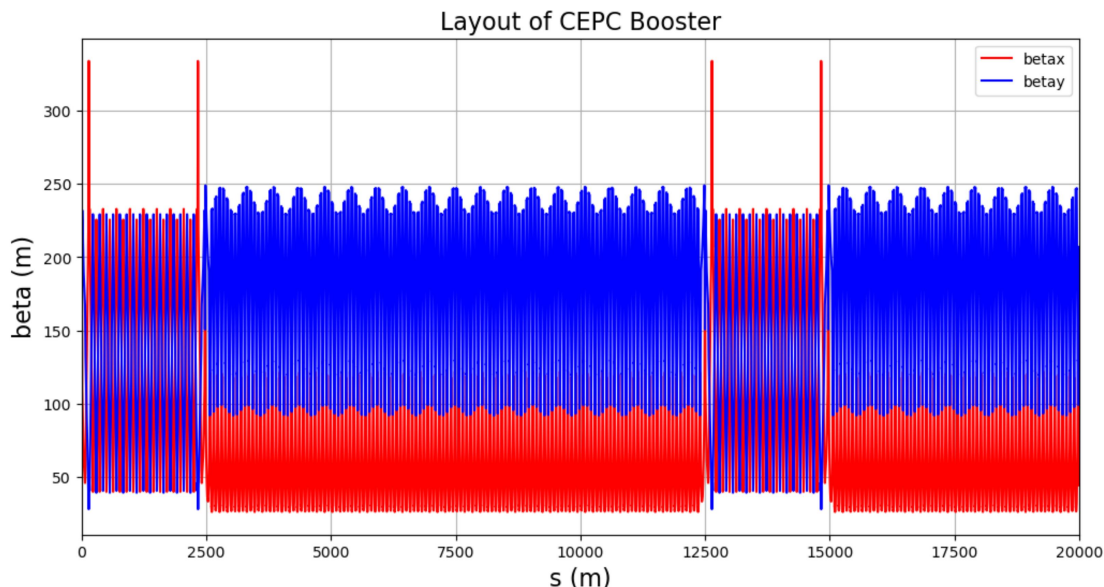
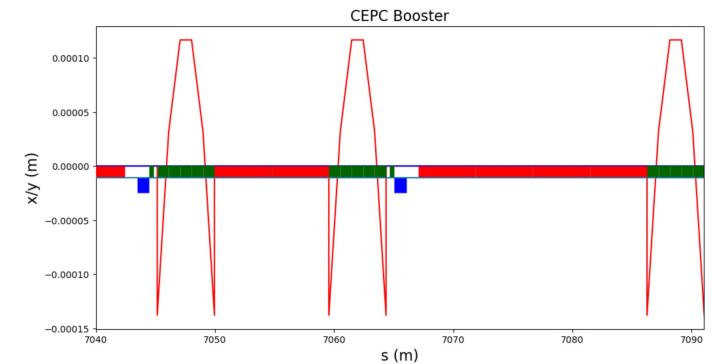

Modeling and optics

Yuanyuan Wei, Liangsheng Huang, Tianmu Xin,

CSNS RCS 6D Optics Comparison between MAD-X and APES

Beta Function Comparison

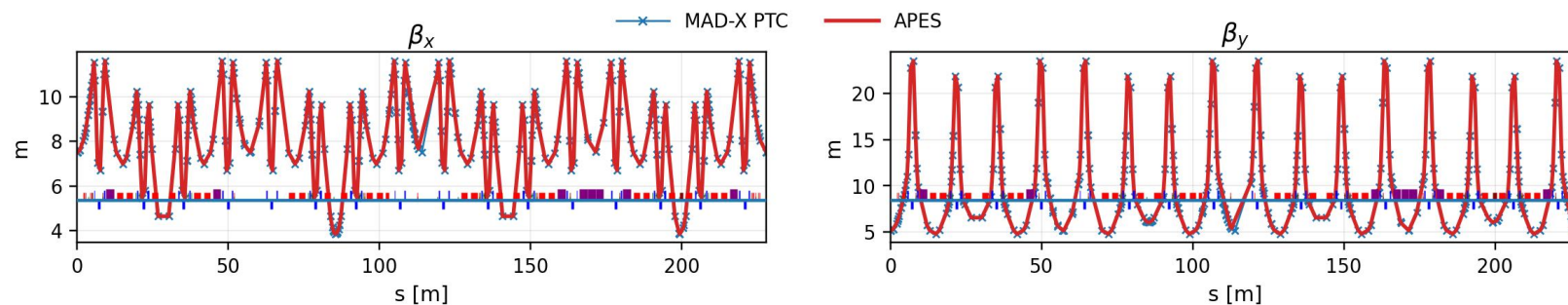

Working Point Comparison

Plane	MAD-X PTC	APES	$ \Delta $
x	0.85999991	0.86014078	1.41e-04
y	0.80000012	0.80028596	2.86e-04
z	0.00623065	0.00623110	4.53e-07

Closed Orbit Comparison

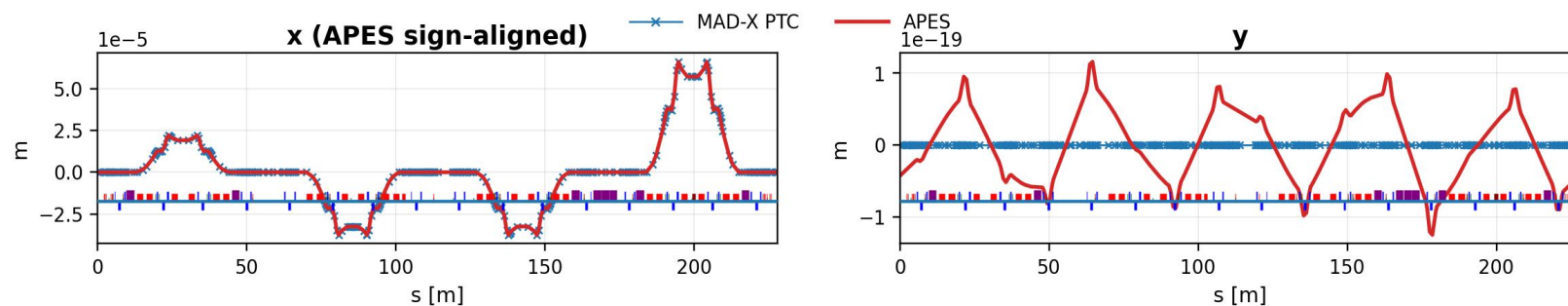

Dispersion Comparison

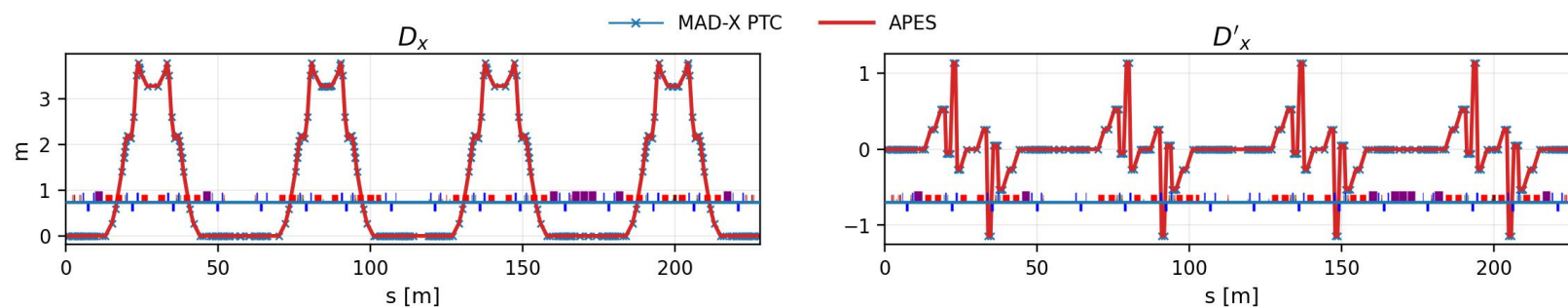

Layout of CSNS_RCS

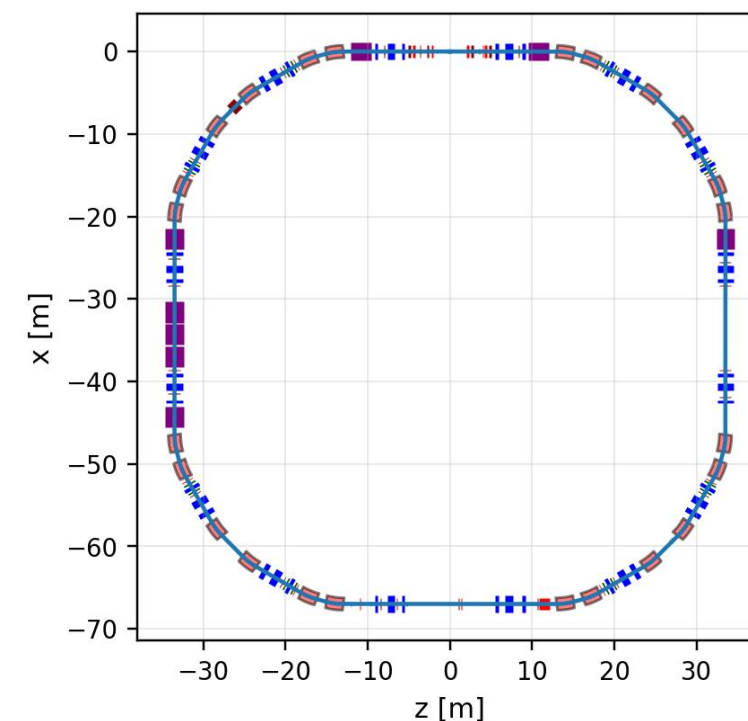

Tracking and Simulation

Simulation of CEPC Higgs (symmetric)

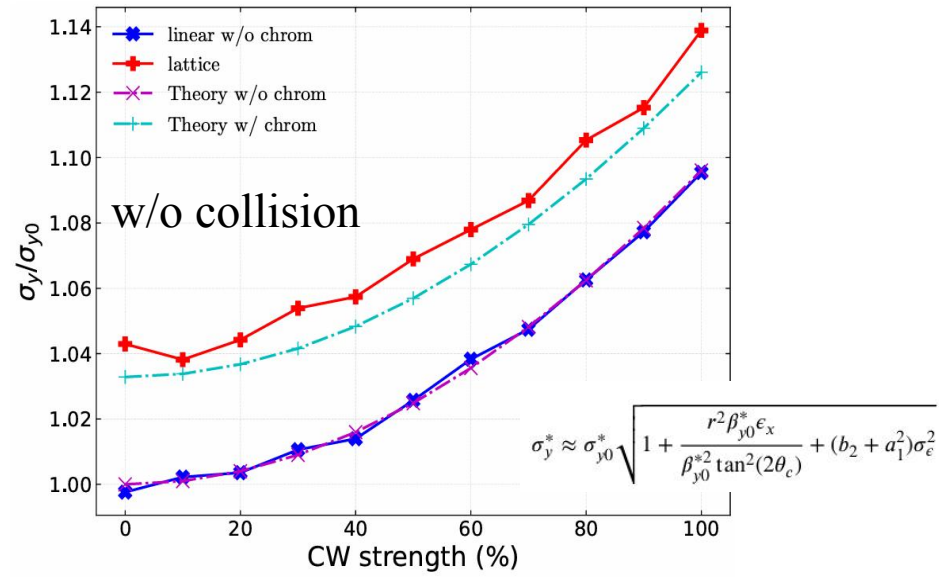
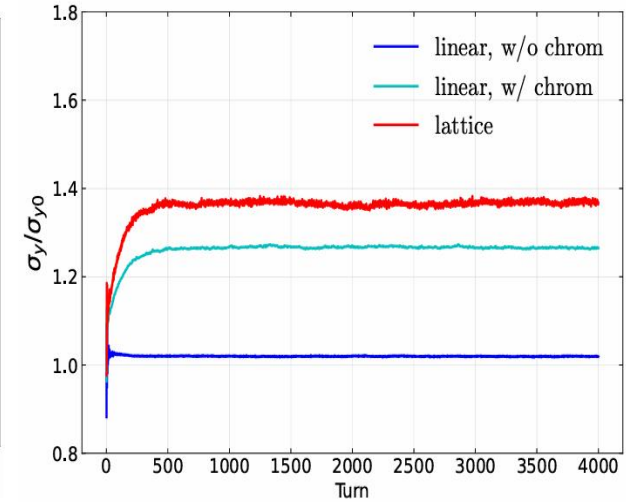
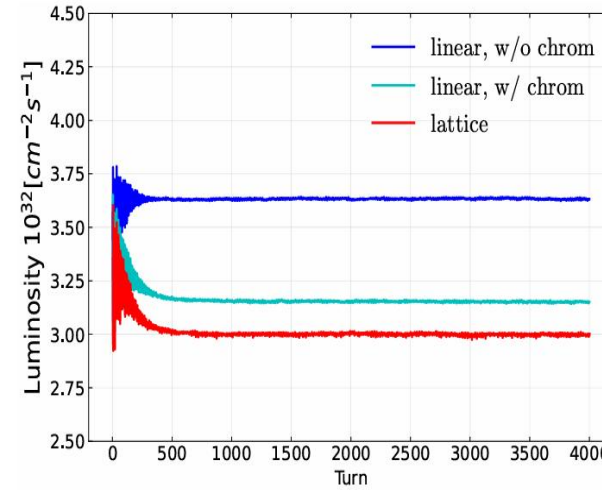
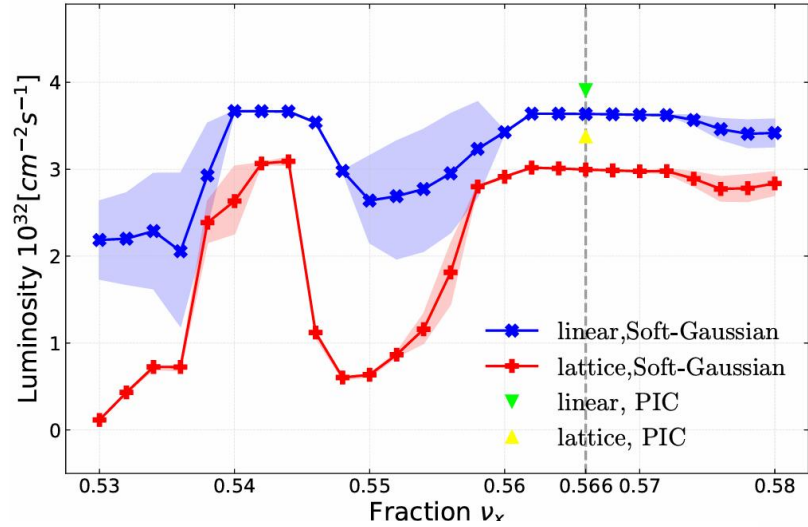

- 16% luminosity loss due to lattice
- Chromaticity and crab-waist induce the reduction

Tracking and Simulation

Simulation of Swap-out injection (Higgs)

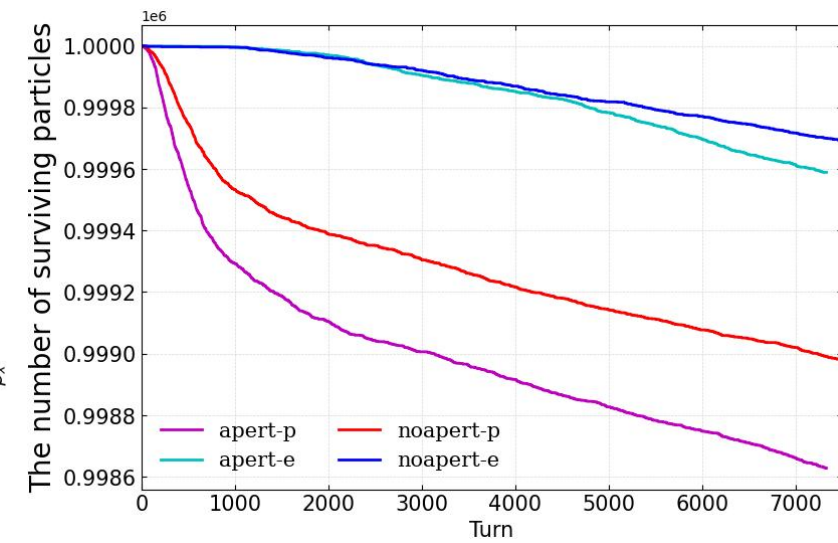
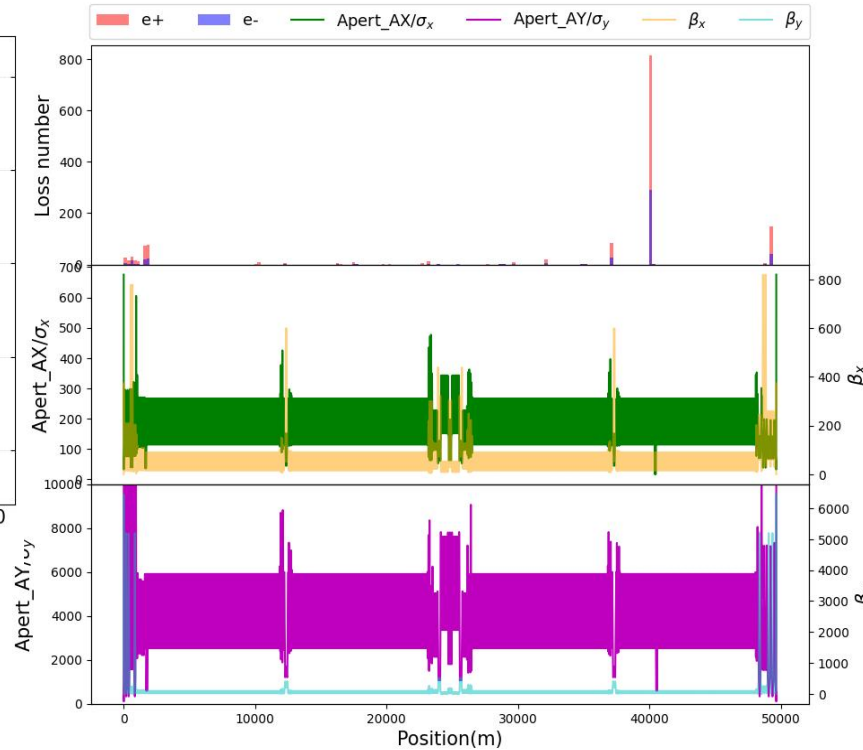
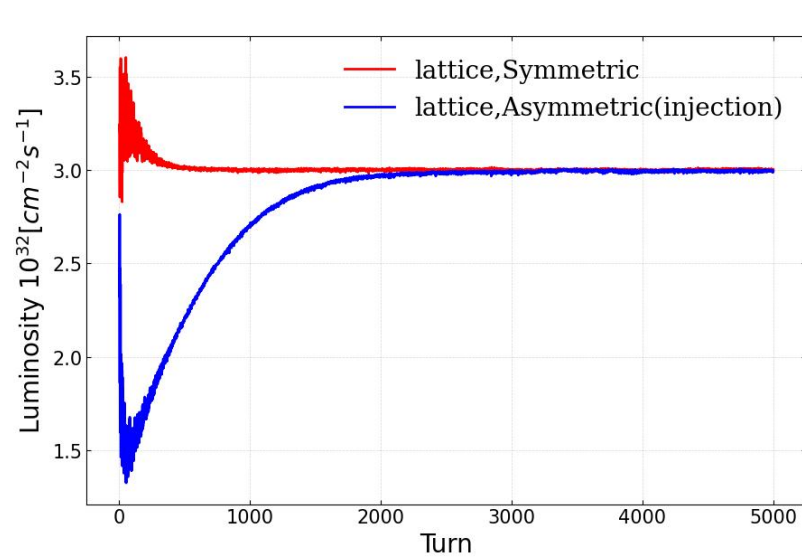

$e^+(\text{inj.}) / e^-$
 w/o apert: 39/42(min)
 w/ apert: 29/37(min)

- Initial beams: e^+ (collider SR equilibrium) vs e^- (booster SR equilibrium)
- Luminosity: same between symmetric and asymmetric collision
- A clear lifetime reduction for e^+ is observed with physical aperture included.

Tracking and Simulation

SuperKEKB Cross-combination simulations

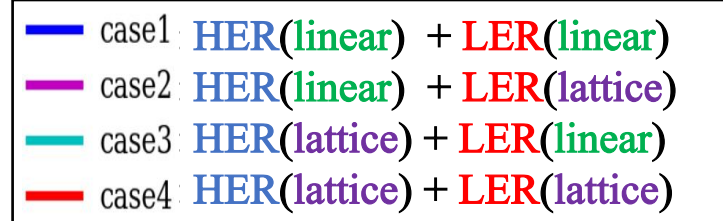

case2: LER(lattice) Resulting in a luminosity decrease (-6%)

case3: HER(lattice) Causing a larger vertical size increase ($>1.7\times$) and luminosity decrease (-27%)

case4: Luminosity decrease is approximately the superposition of the two lattices' effects (-32%)

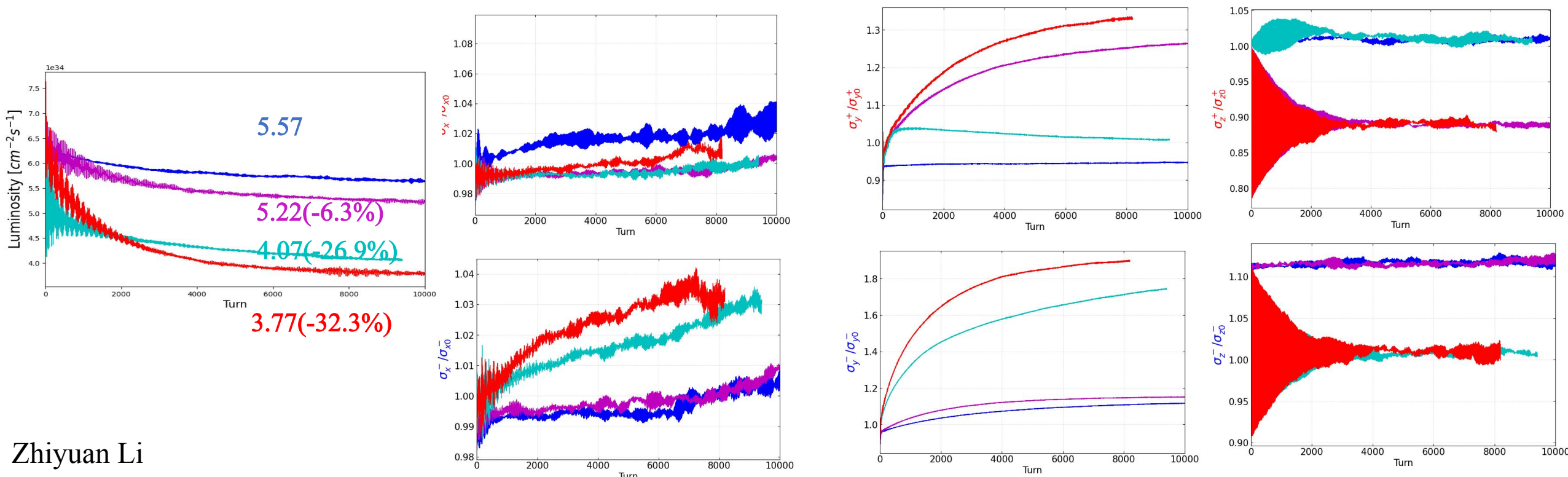

Tracking and Simulation

SuperKEKB with error

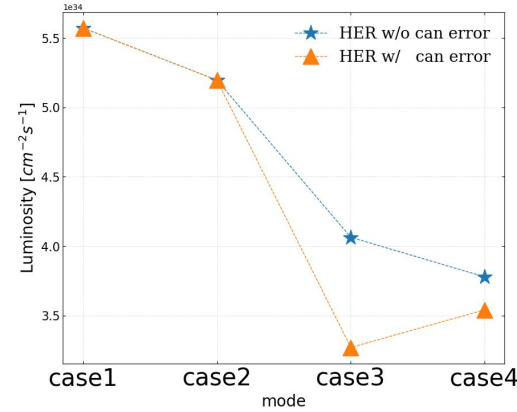
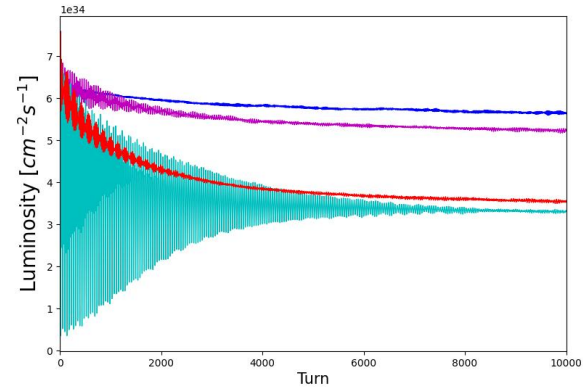
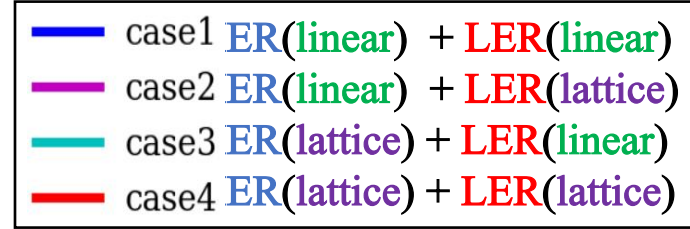

Consistent with prior simulations:

HER(lattice) drives larger vertical size growth + greater luminosity drop

Compare:

greater σ_y - growth

the luminosity decreases.

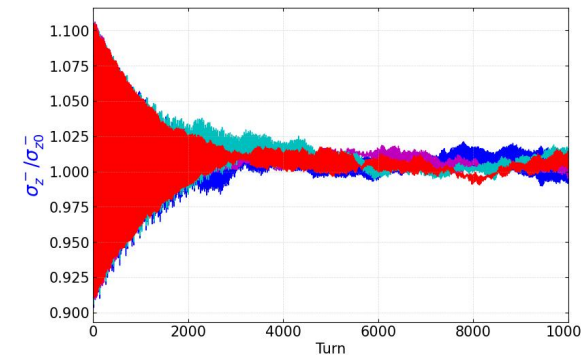
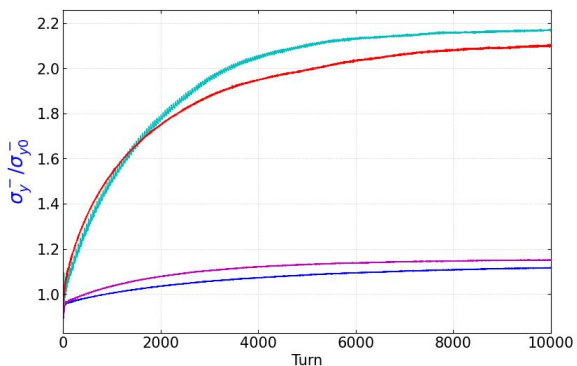
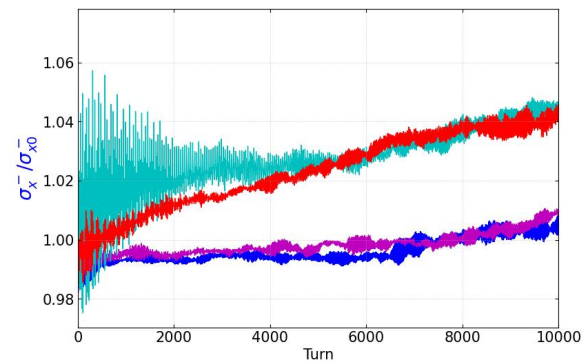
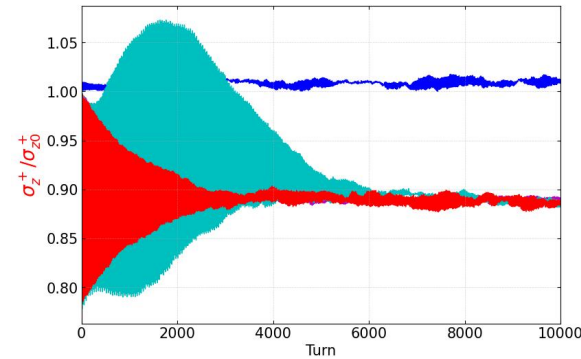
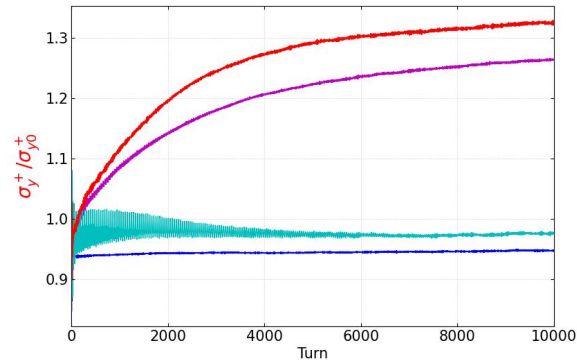
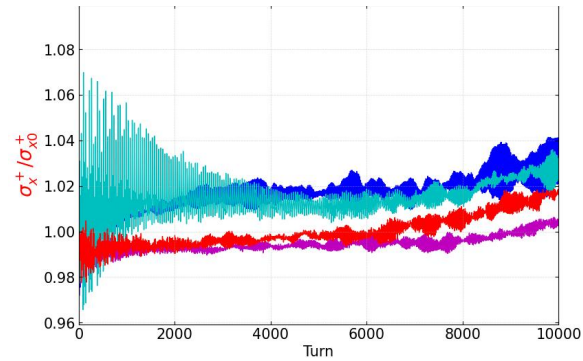

Tracking and Simulation

Spin Tracking

- Thomas-BMT equation implementation via quaternion representation
- Supports element-by-element spin tracking

$$\frac{d}{ds} \mathbf{S} = \left(\frac{1 + \mathbf{h} \cdot \mathbf{r}_t}{c\beta_z} \boldsymbol{\Omega} - \mathbf{h} \times \hat{\mathbf{z}} \right) \times \mathbf{S}$$

$$\boldsymbol{\Omega} = -\frac{q}{mc} \left[\left(\frac{1}{\gamma} + G \right) c\mathbf{B} - \frac{\gamma cG}{1 + \gamma} (\boldsymbol{\beta} \cdot \mathbf{B}) \boldsymbol{\beta} \right]$$

Already supported	HSBend, VSBend, Quadrupole, Sextupole, Solenoid
Under development	Sol-quad, Cavity, Patch...

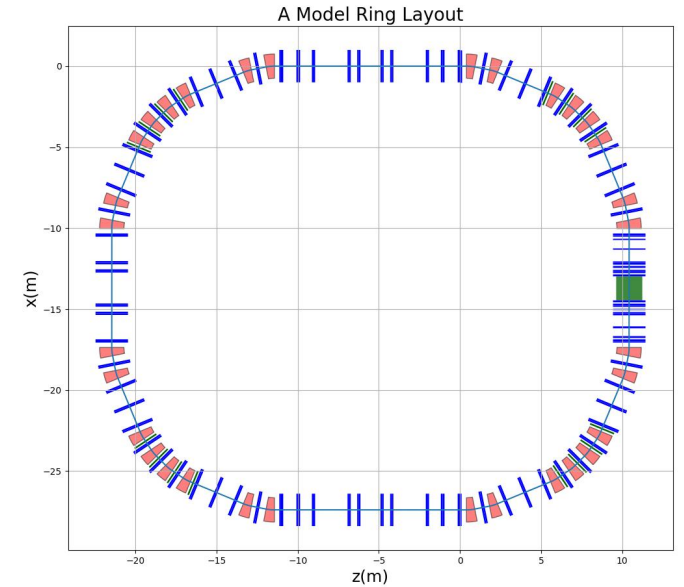

element-by-element spin tracking benchmarked against Bmad

Spin Vector Evolution in The Model Ring

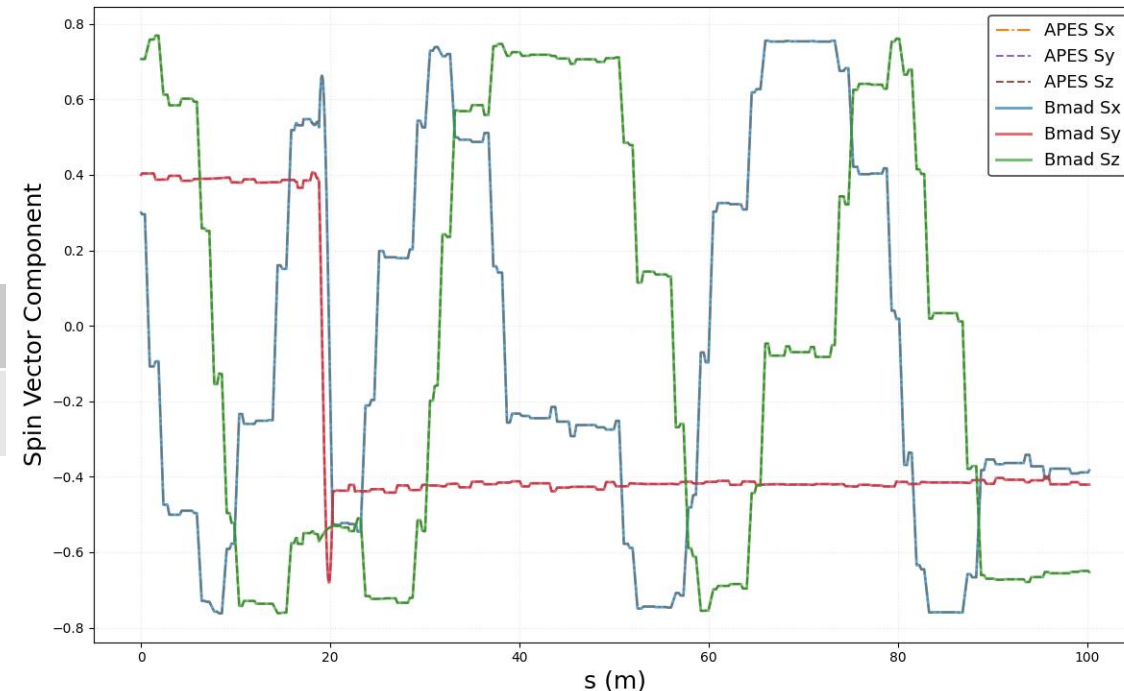

Tracking and Simulation

Long range wake module

- The module currently supports longitudinal and transverse dipole wake.
- Resonator model and/or tabulated wake function.
- Benchmarked with a toy case in CEPC with an artificially enhanced kicker. We expect to see an unstable coupled bunch mode $\mu = 883$ building up. The growth rate given by analytical formula is 310 Hz.

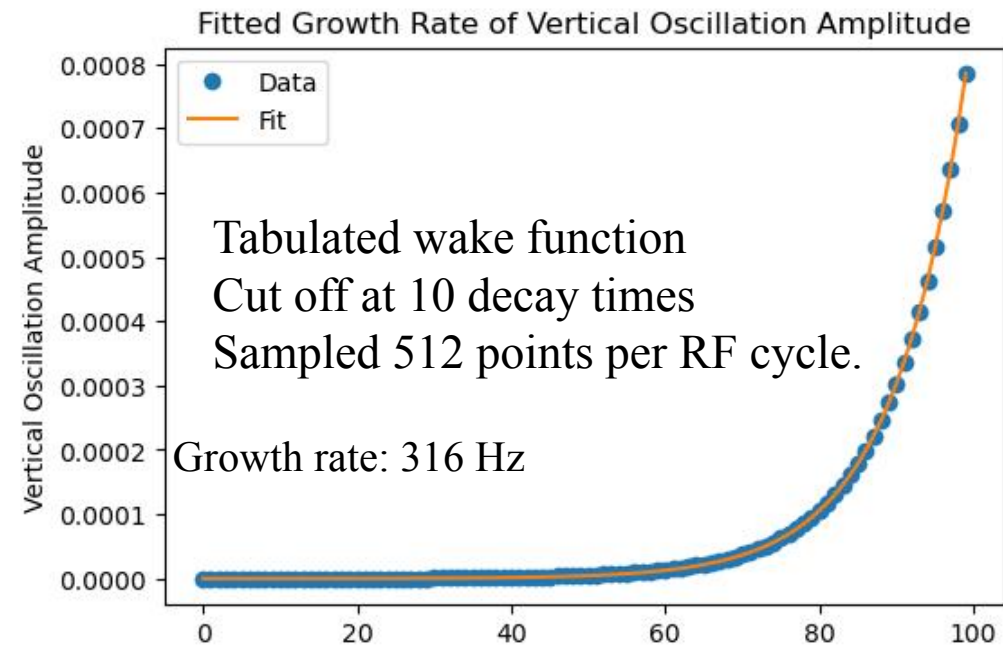
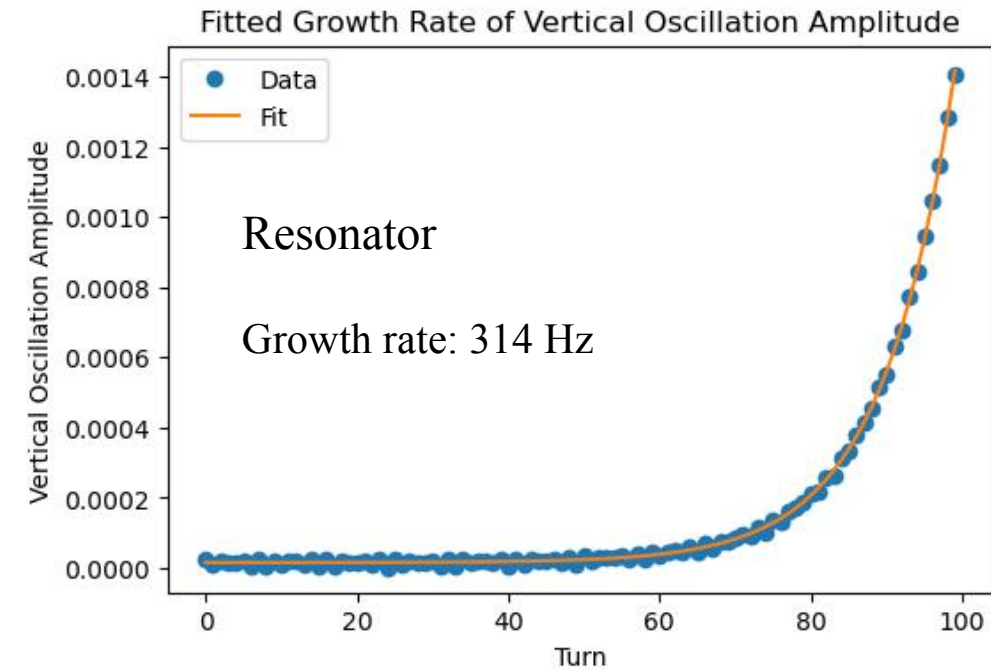

What comes next ?

- Tighter collaboration with CEPC design team
- Development of More Features;
 - Feedback module
 - ML-enhanced Space charge effect calculation
 - Electron cloud, FFM and surrogate model
 - Ion effects
 - Intra-beam Scattering
 - ...
- Harness the power of Large Language Model (LLM).
 - Agentic skills
 - Developing the training course for the code (?)
 - GUI (?)
- Beyond CEPC

Possible way of utilizing machine learning and LLM

Back end: Machine learning for surrogate models to speed up the expensive evaluations. For example the space charge effect.

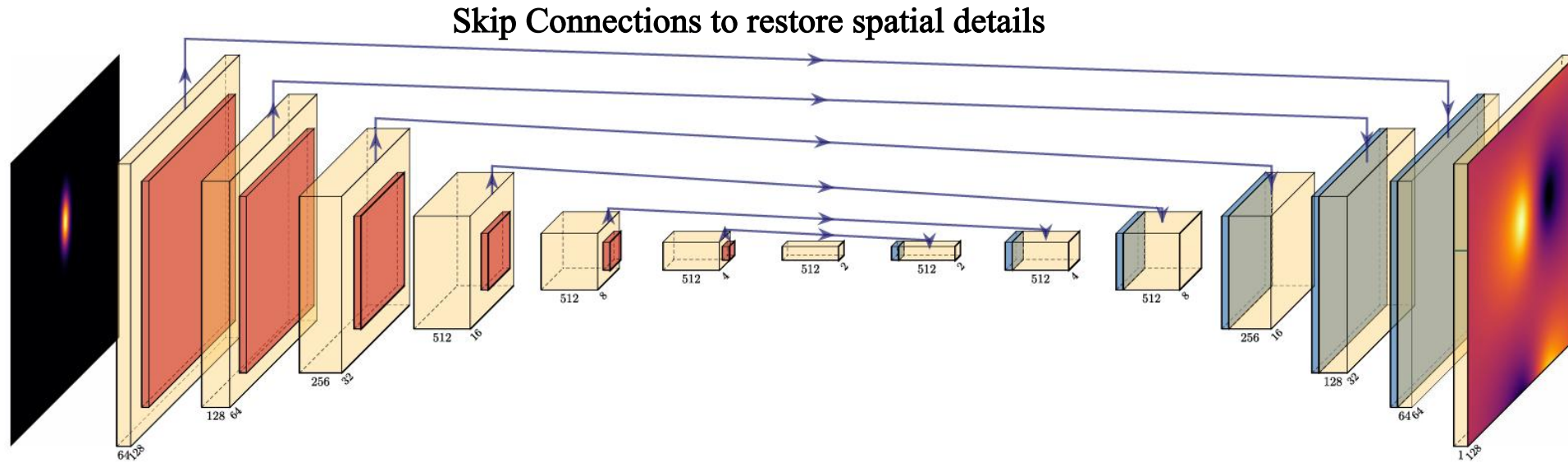

Encoder-decoder structure of a U-Net to construct a Hamiltonian of a 2D histogram of a bunch.

J. Wan, ML Workshop 2026, IHEP, <https://indico.ihep.ac.cn/event/29086>

Possible way of utilizing machine learning and LLM

Front end: Agent skills for different tasks.

For the frequently used tasks, we can develop some generic workflow that can be further distilled into ‘skills’ for the AI agent to invoke every time the job is given. For example the benchmark between MAD-x and APES for the CSNS RCS we’ve shown is generated purely by the Codex agent guided by the optics calculation and MAD-X benchmark skill.

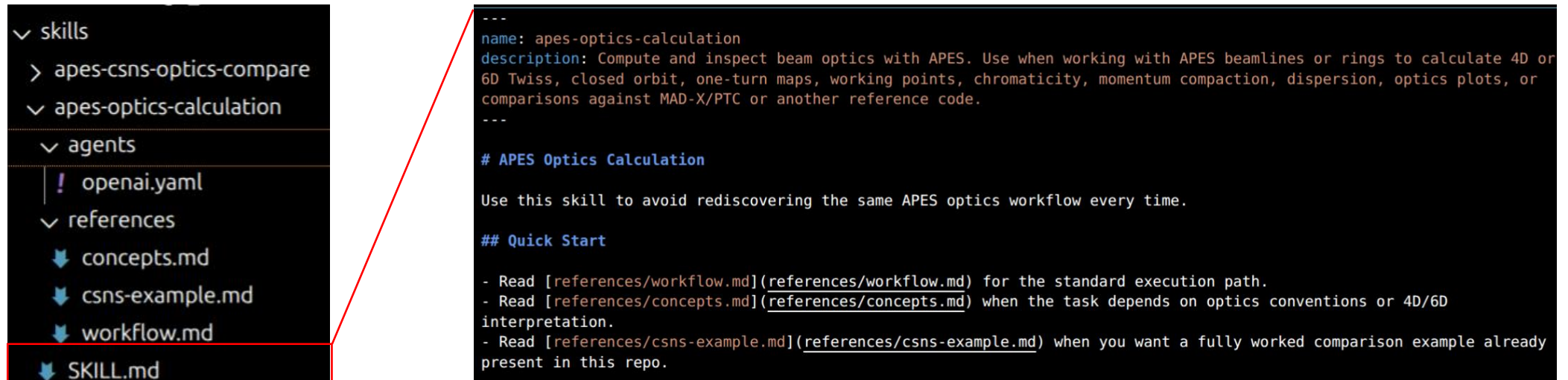

```
---
name: apes-optics-calculation
description: Compute and inspect beam optics with APES. Use when working with APES beamlines or rings to calculate 4D or 6D Twiss, closed orbit, one-turn maps, working points, chromaticity, momentum compaction, dispersion, optics plots, or comparisons against MAD-X/PTC or another reference code.
---

# APES Optics Calculation

Use this skill to avoid rediscovering the same APES optics workflow every time.

## Quick Start

- Read [references/workflow.md](references/workflow.md) for the standard execution path.
- Read [references/concepts.md](references/concepts.md) when the task depends on optics conventions or 4D/6D interpretation.
- Read [references/csns-example.md](references/csns-example.md) when you want a fully worked comparison example already present in this repo.
```

We are still exploring the potential benefit of using the agent+skill instead of the old-fashioned workflow which is much more rigorous but requires a deeper understanding to the code.

Possible way of utilizing machine learning and LLM

The necessity of having a GUI is under consideration.

The screenshot displays the APES Accelerator Physics Emulation Studio interface, which is divided into several functional panels:

- Machine Parameters (机器全局参数):** Shows Beam Energy (GeV) set to 2.5 and RF Frequency (GHz) set to 122348920232887856.
- Lattice Element List (Lattice 元件列表):** A table listing 8 elements with their names, types, lengths, and main parameters.
- Lattice Visualization (Lattice 可视化):** A 2D plot showing the circular arrangement of various elements (Quadrupole, Drift, Cavity, etc.) around a central axis.
- Calculation Engine Control (计算引擎控制):** Includes buttons for running Twiss calculations and particle tracking, along with input fields for particle count (20000) and tracking turns (1000).
- Monitoring Graphs (监控图表):** Two real-time plots: 'Beta X' (red line) and 'Dispersion' (blue line), both showing periodic oscillations over time.
- Real-time Monitoring Log (实时监控日志):** A terminal window showing the execution of the `calRingTwiss` command and its parameters.

元件名称	类型	长度 (m)	主要参数
1 BEGL...	Marker	0.0	
2 DRIFT0	Drift	0.0865	
3 FOIL01	Marker	0.0	
4 DRIFT1	Drift	0.7835	
5 FOIL02	Marker	0.0	
6 DRIFT2	Drift	1.135	
7 INBH1	HSBe...	0.3	
8 DRIFT3	Drift	0.25	

```
>>> 正在绘制lattice...
>>> Lattice绘制完成
>>> Lattice加载成功!共357个元件
```

```
>>> calRingTwiss 参数:
calChromaticity=True,
calMomentumCompactionFactor=True,
saveOptics=True, useRF=True,
frequency=10.0, harmonic=2,
radiation=True, autoFrequency=True,
```

Project Progress

GPU	Ready	Planned	Ready	Ready	Planned	Ready	Planned	Planned	Planned	Planned	Ready	
multi-CPU openMP and/or MPI	Ready	Under development	Ready	Ready	Under development	Ready	Planned	Planned	Planned	Planned	Ready	
CPU	Ready	Ready	Ready	Ready	Ready	Ready	Ready	Under development	Under development	Under development	Ready	
Features	Optics Calculation	Realistic magnet modeling	Beam-beam	Radiation	Long range wake	Beam cavity interaction	Spin	Electron cloud	Ion effect	IBS	Space charge	More to come



Summary

- APES is becoming more and more productive.
- APES is under active development.
- We are working on the release of alpha test.
- Hopefully the beta test will come soon after alpha.
- Your usage feedback will be greatly appreciated.

Backup Slides

multipoles including fringe fields and crosstalk

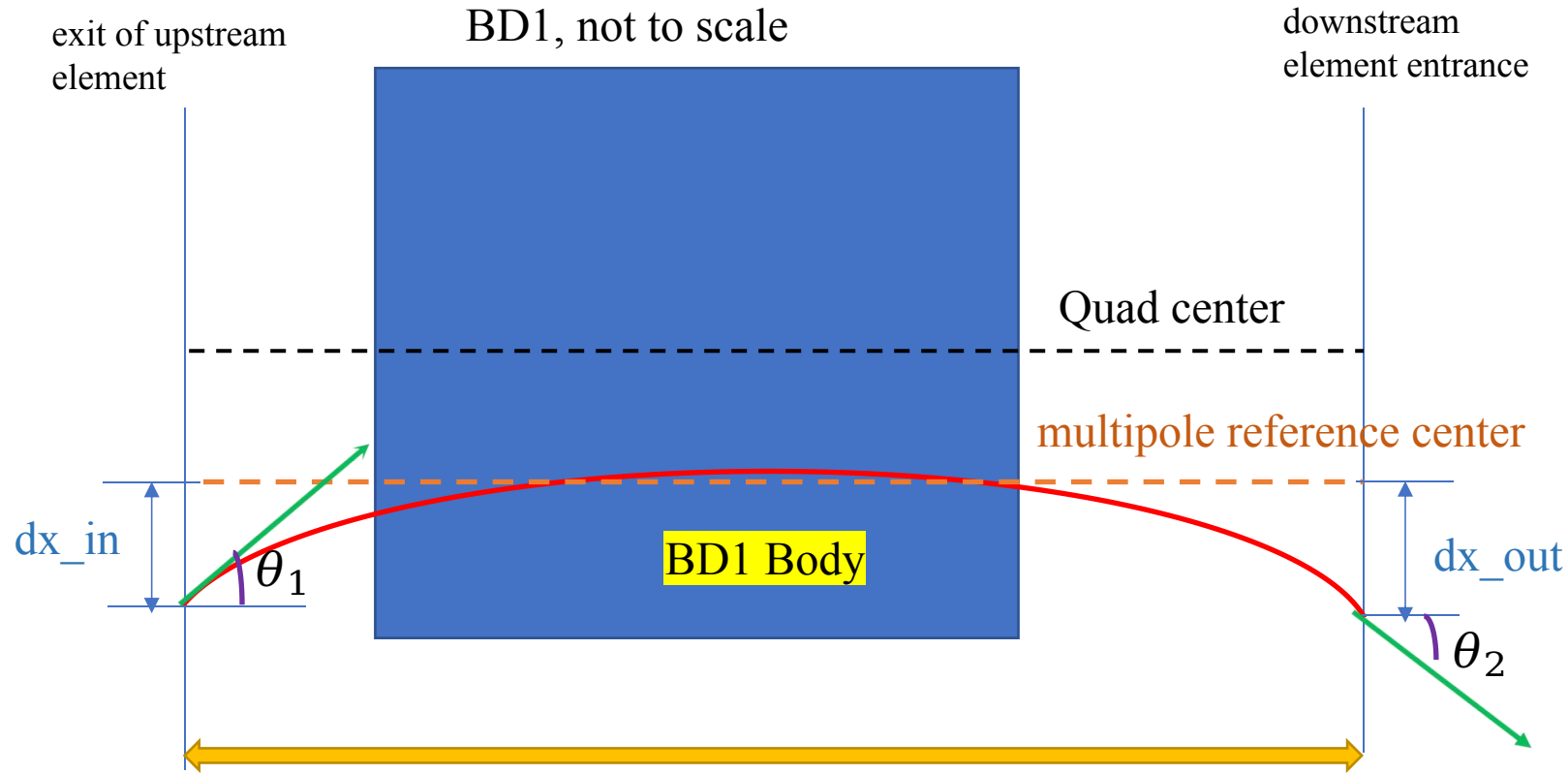

Region of Multipole L ($\sim 1.39\text{m}$, ~ 120 multipole)

red line L: upstream drift (L_1) + BD1 arc length (L_0) + downstream drift (L_2)

θ_1 : Bend entrance angle; θ_2 : Bend exit angle

Multipole region length $L' = L_1 * \cos(\theta_1) + L_0 * \cos(\theta_1 + \theta_2) + L_2 * \cos(\theta_2)$

- 3D fields including fringe field and cross talk between magnets.
- The region between the exit of the upstream element and the entrance of the downstream element is defined as the region of multipole.
- The 3D field is described by a series of multipoles
- Use the combination of the patches to switch between the coordinate systems.

Beta functions and dispersion still show some discrepancies.

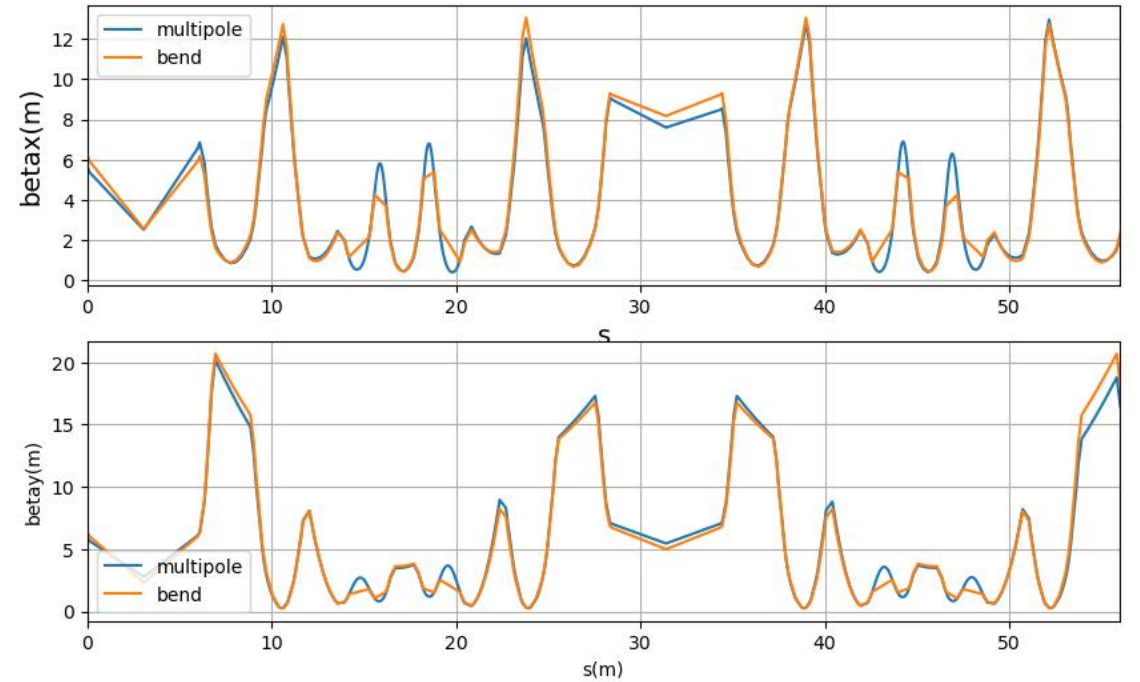
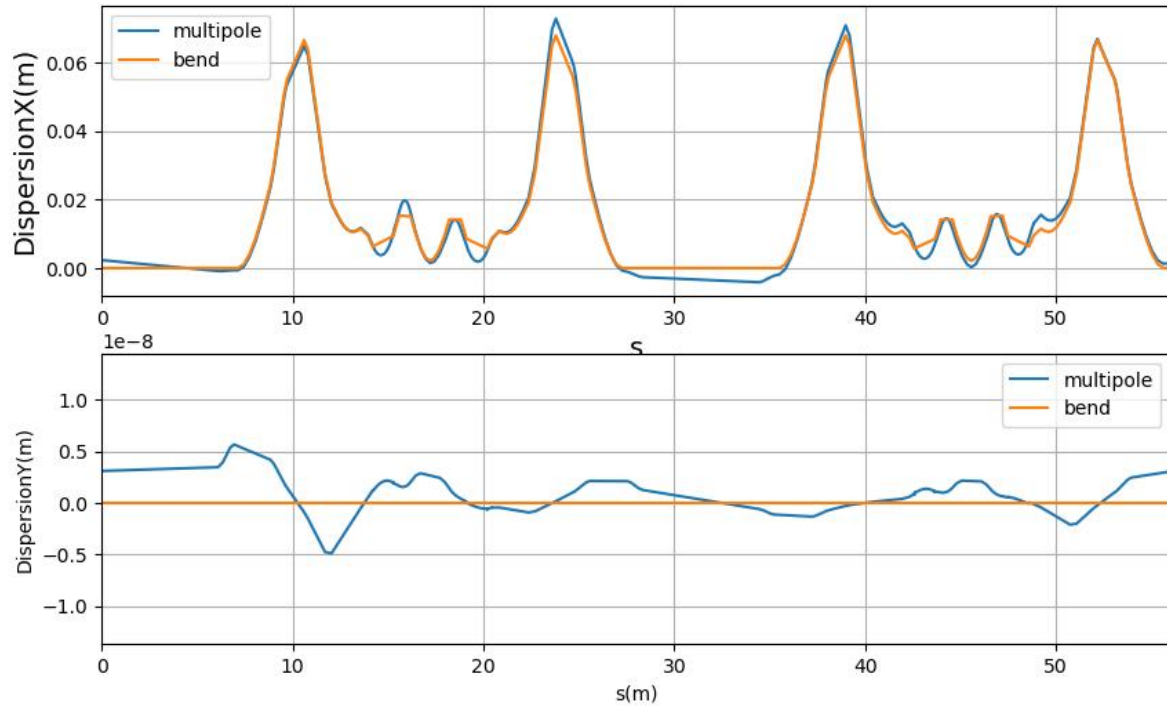

Modeling and optics

Modeling HEPS SR with APES

Closed orbit (wo./w. radiation)

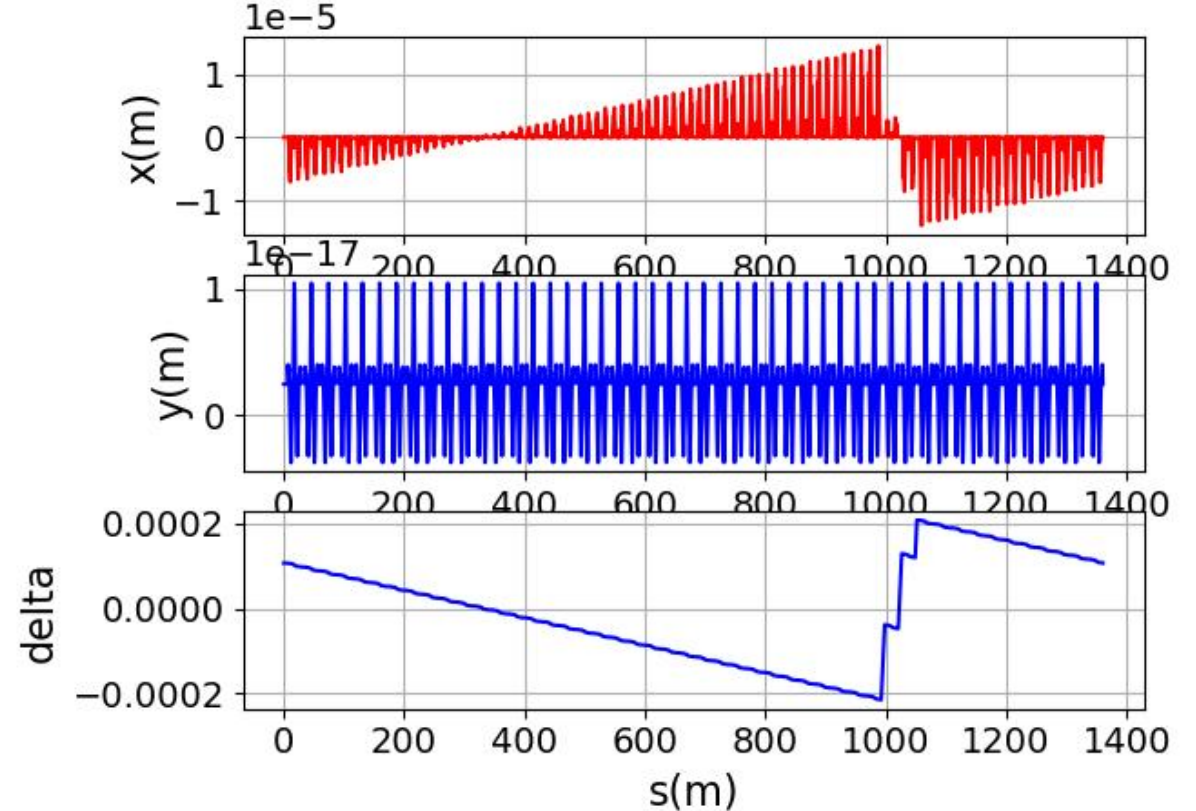
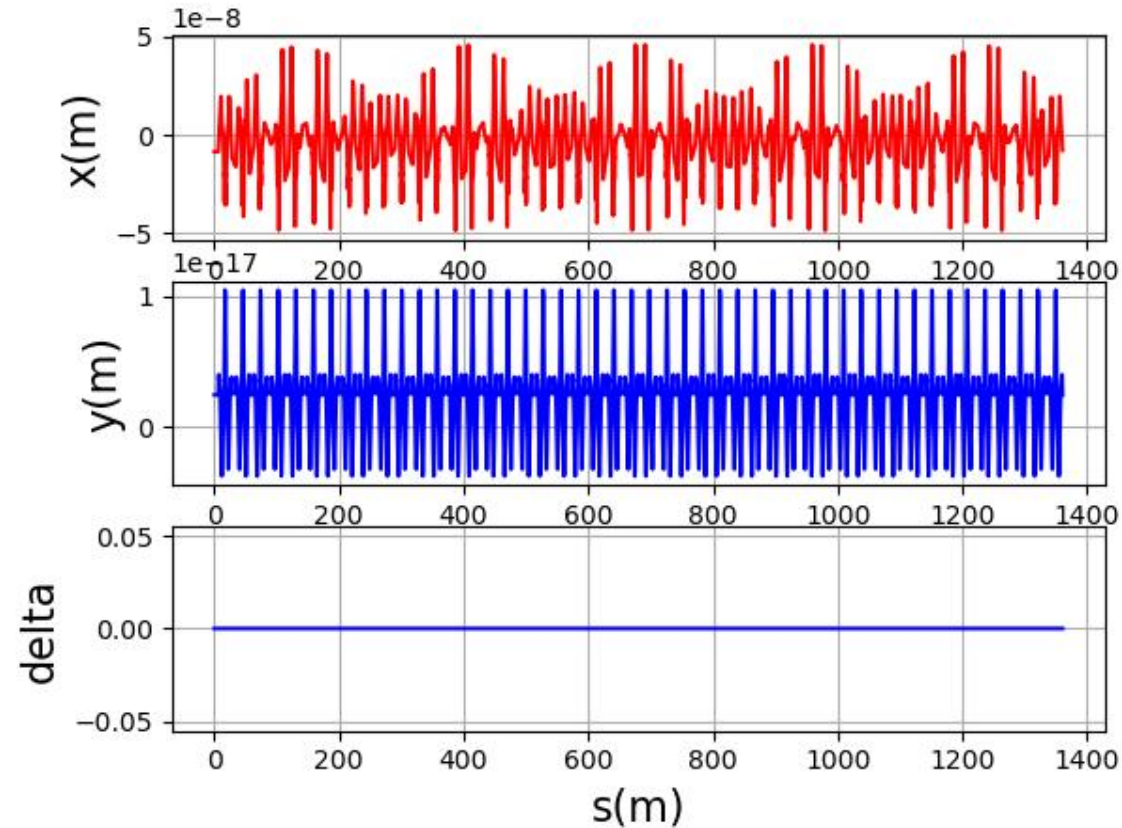

- Lattice was built with BEND in Elegant, closed orbit is 0;
- Lattice was rebuilt with Patch+QUAD in APES,
 - without radiation, COD is at 10^{-8} m level.
 - with Radiation (and RF), COD goes to 10^{-5} m level.

Modeling and optics

Modeling HEPS SR with APES

Beta-beating (and the effect of radiation)

apes to elegant w/o rad

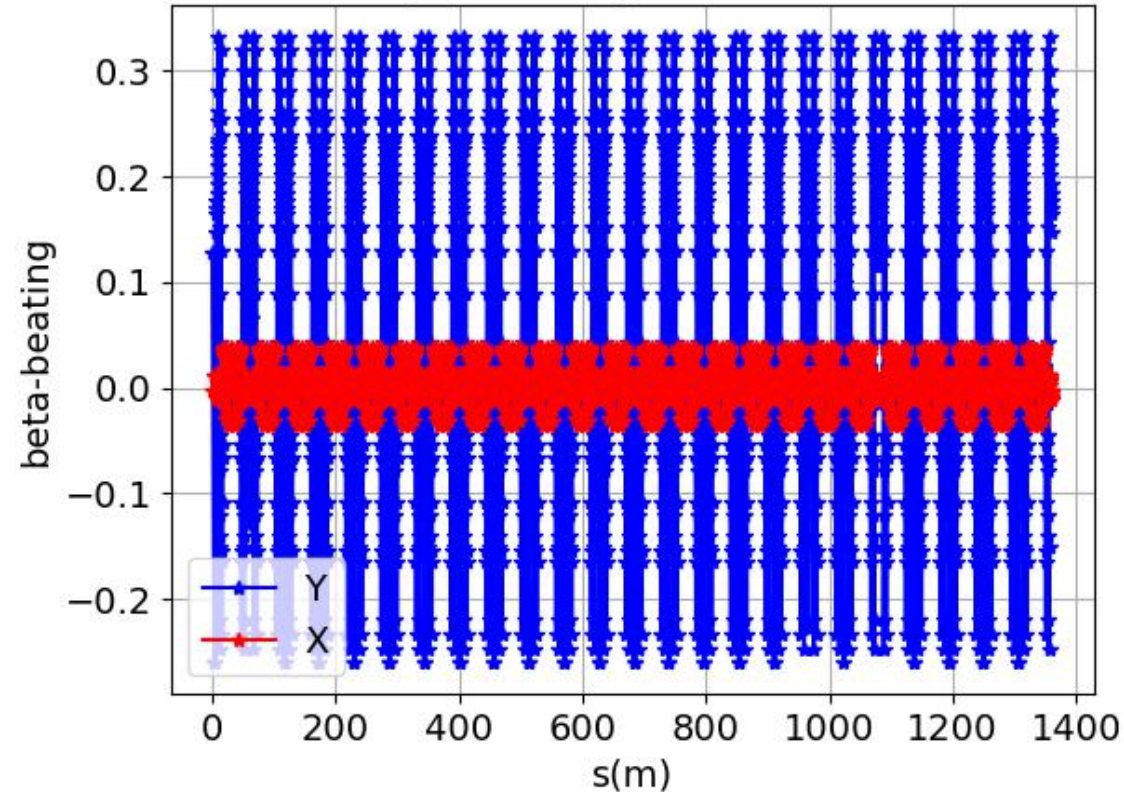

apes_with_rad to apes_wo_rad

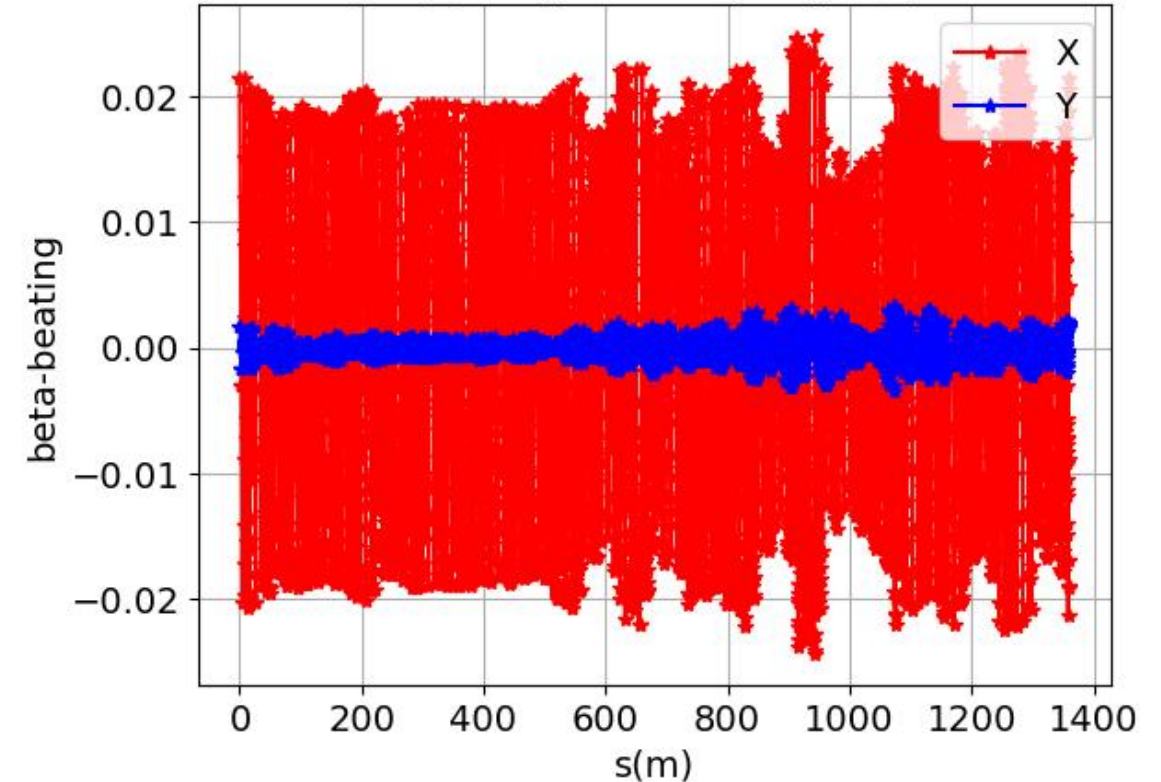

- compare to elegant: beta-beating \sim 5%、33% \implies there is a integer number of difference in the working point for the off-center quad
- In APES: radiation induced beta-beating(hori. and vert.) is \sim 0.5%、2.5%

Modeling and optics

Modeling HEPS SR with APES

Dispersion (and the effect of radiation)

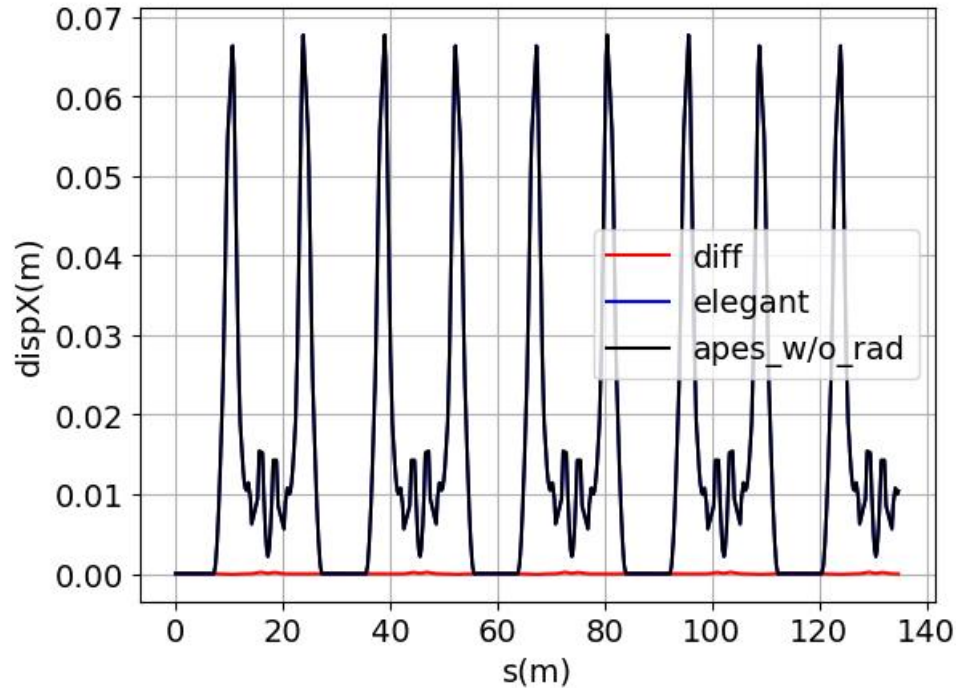

$Dx_ave(\text{apes-elegant}): 1.0069194426867802e-05$

$Dy_ave(\text{apes-elegant}): -1.8554290666412e-18$

$Dx_rms(\text{apes-elegant}): 5.891495402200572e-05$

$Dy_rms(\text{apes-elegant}): 2.6604152570272852e-17$

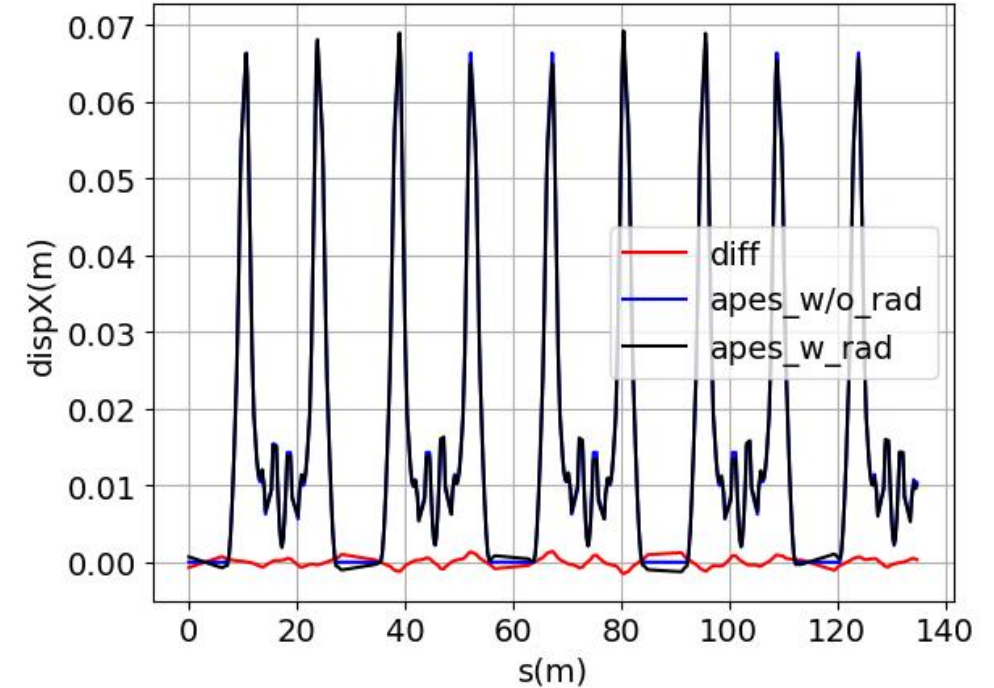

$Dx_ave(\text{apes-apes0}): 2.2268068295258565e-05$

$Dy_ave(\text{apes-apes0}): 2.0367974243171904e-17$

$Dx_rms(\text{apes-apes0}): 0.0005724117987769504$

$Dy_rms(\text{apes-apes0}): 1.2861609007772154e-15$

- Compare with Elegant: the average and rms values for horizontal and vertical dispersion are $\sim 1e-5$ and $1e-17$, respectively.
- Radiation induced horizontal and vertical dispersion are at the $2e-5$ and $6e-4$ level, respectively.