

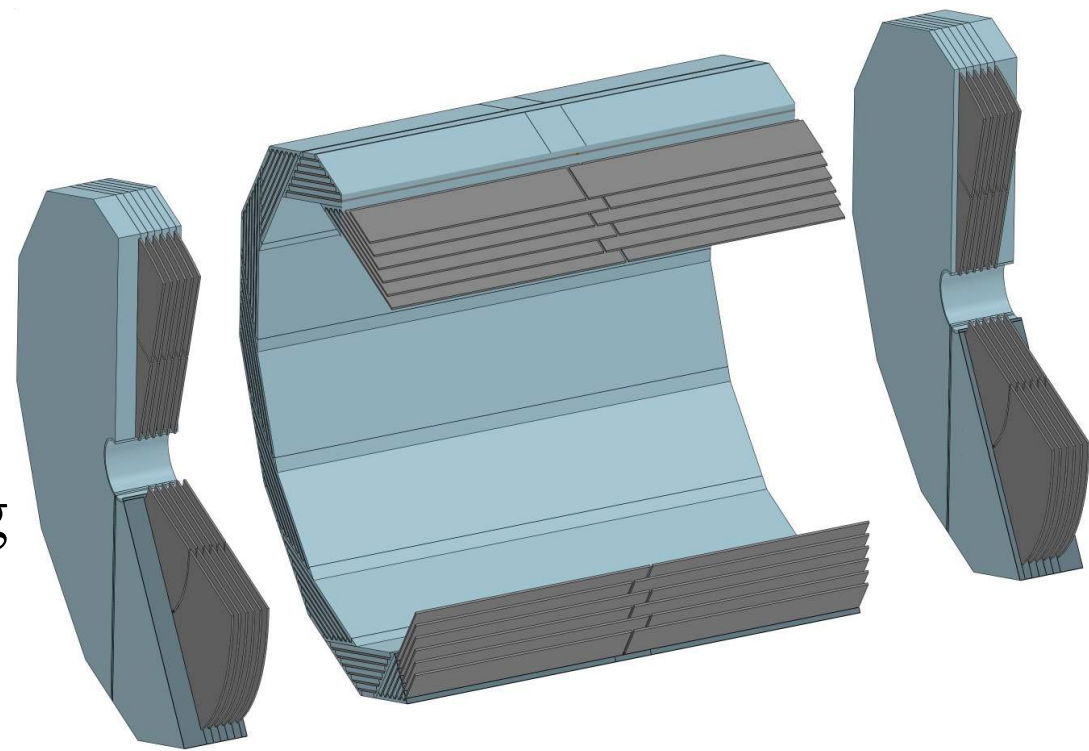

# Plan and status of Muon Detector

Xiaolong Wang (on behalf of Muon Group)  
Fudan University  
CEPC Detector and Physics Plenary Meeting  
June 10th, 2026

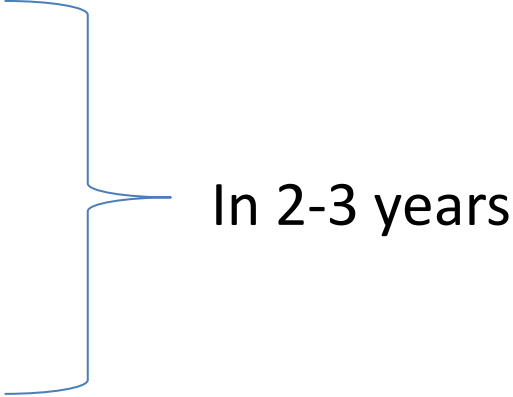

# Concerns

- Technology is ready for a module prototype. But there is still room to improve the quality of PS bar.
  - We need systematic studies with long-term CR tests.
  - Optimization of the geometry for better coverage.
  - Improve the software and simulation of the muon detector.
  - Study with physics simulation → Potential for new physics.
  - Radiation hardness.       Since the third year.
- 

In 2-3 years

**Table 9.3:** Average hit rate in the PSUs of the endcaps due to backgrounds at the Z pole.

Layer#	Maximum hit density ( $\times 10^{-7} / \text{cm}^2 / BX$ )	Maximum hit rate (Hz/ $\text{cm}^2$ )	Average hit rate (Hz/ $\text{cm}^2$ )	Occupancy ( $\times 10^{-4}$ )
1	7.86	10.24	0.80	7.6
2	7.86	10.24	0.96	7.6
3	10.48	13.66	1.22	10.0
4	9.16	11.96	1.16	8.8
5	6.58	8.60	0.88	6.2
6	5.24	6.82	0.28	5.0

FDU, IHEP, Nankai, HNNU;  
JINR, HSE, LPI, MIPT

# Module prototype

- The barrel module structure, with a length up to 5m!
- Key advantage: FEB inside module.
  - Need to design a preliminary FEB.
  - We are revising our current DAQ with 250MSPS.
- We will build several layers of detector modules and perform CR tests.

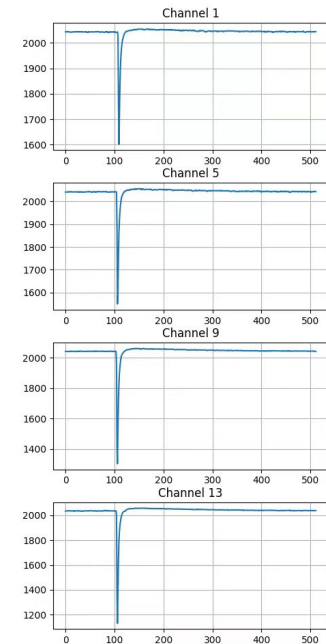
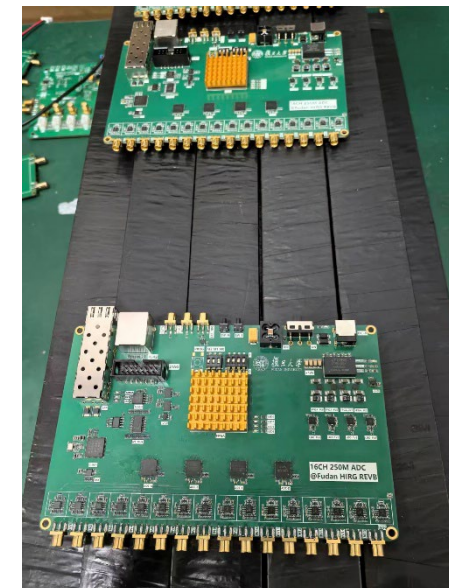
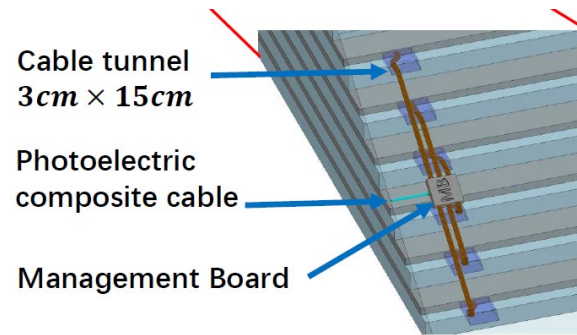
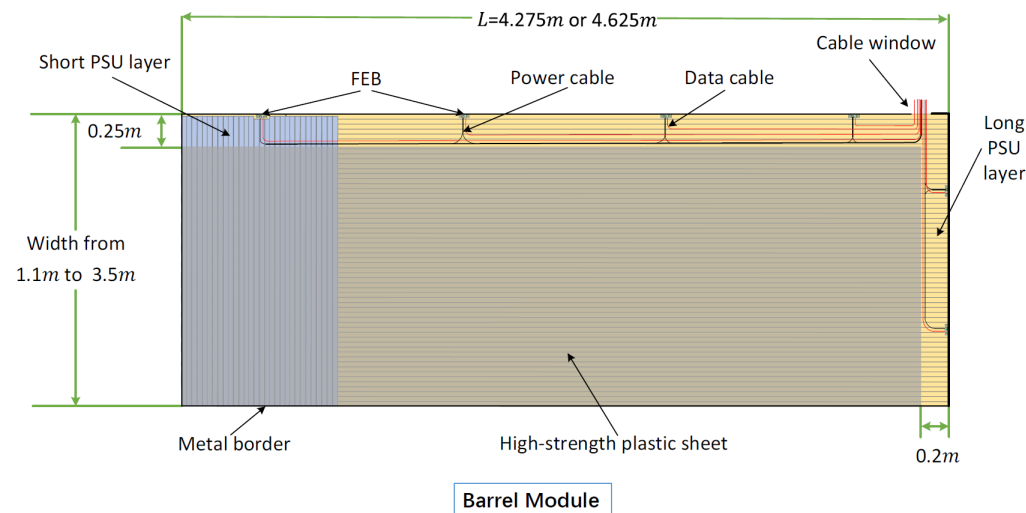
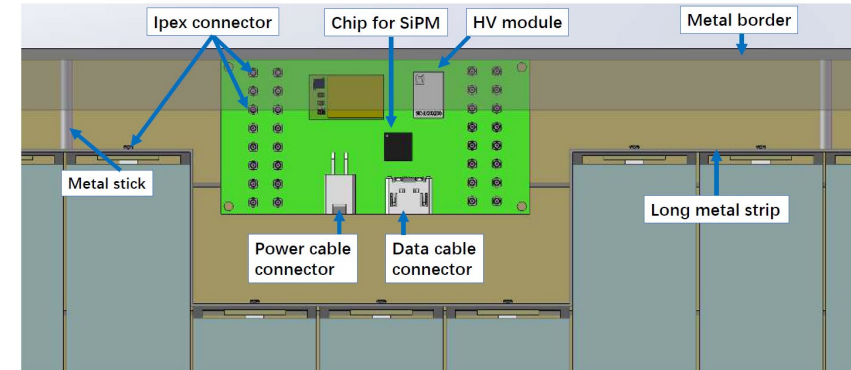

# Software and simulation

- Optimization of geometry coverage.
- Study of standalone tracking for displayed vertex.
- Physics simulation for physics impact and new physics.

HSE, Nankai, HNNU

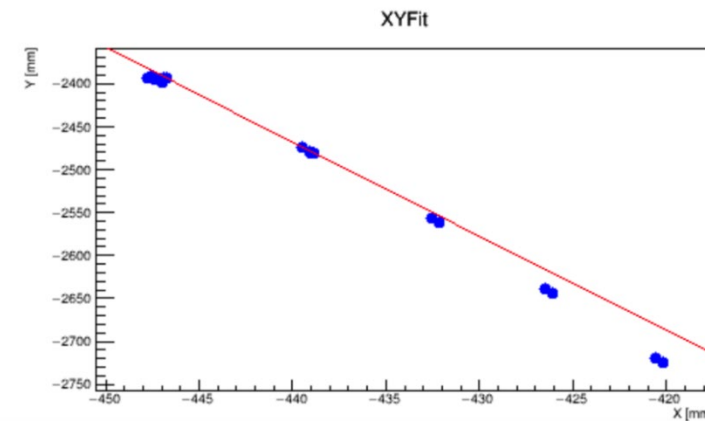
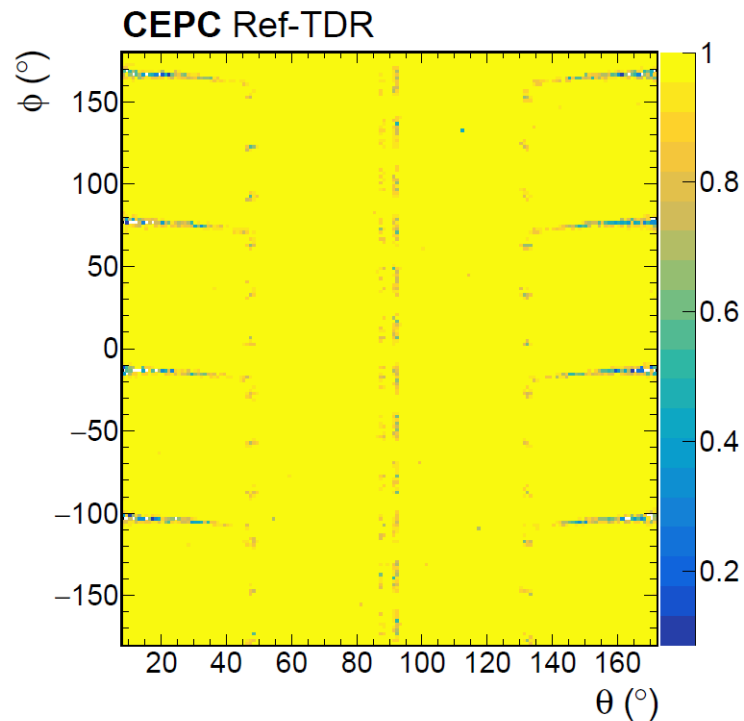

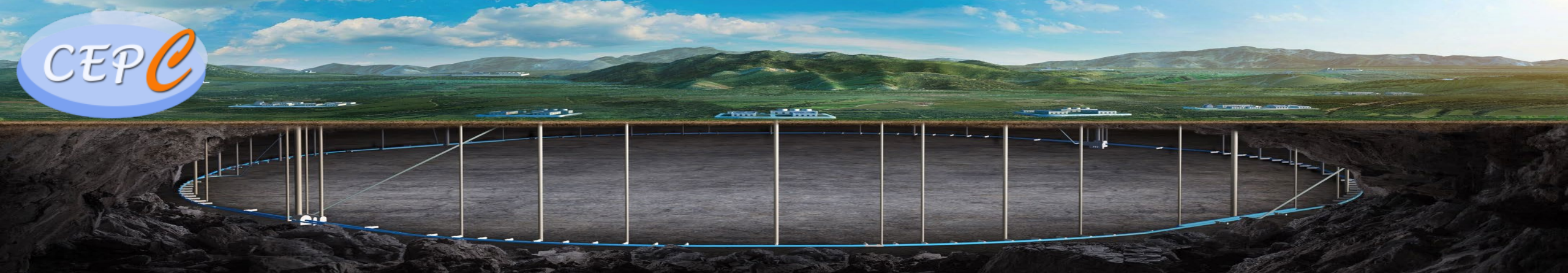

**Thank you for your  
attention!**