

# Overall Status and Plan for the Cherenkov detector

Zhonghua Qin

CEPC physics and detector plenary meeting

June 10, 2026

# Overview of the status and plan

## ● **Detector design and optimization (2026-2027)**

- A preliminary conceptual design has been completed, and the first simulation result shows that  $K/\pi$  separation can reach  $3\sigma$  for  $P=20\text{GeV}/c$
- Need to complete and optimize the design, and to have more performance study by detailed simulation
- Need to explore the physics motivations, how is this detector able to beneficial more to physics

## ● **Detector Technologies R&D (2026 – 2030)**

- Radiators and photon sensors
- Mechanics and integration
- Simulation and reconstruction
- Readout electronics
- Prototypes and tests
- CDR and TDR

# Status and plan of the components (1)

## ● **Aerogel radiator (2026-2027)**

- Currently mainly based on BINP's experience and study, which shows silica aerogel with  $n=1.008$  is promising
- However, BINP aerogel is hydrophilic (will absorb ambient moisture), while Belle II's aerogel is hydrophobic
- Plan to test both aerogels' properties at IHEP

## ● **Photon sensor (2026-2028)**

- SiPM has many advantages, chosen as the first option and preliminary requirements specified
- However, given its large dark noise rate after irradiation, study on cooling and annealing is necessary
- Fudan university (Xiaolong's group) has done a lot of tests on different types of SiPMs (HPK, NDL, Huawei...)
- Plan to perform the irradiation study within DRD4
- Will we still continue our own SiPM development, or cooperate with FBK or other companies as discussed before?

## Status and plan of the components (2)

### ● **Mechanics and integration (2026-2028)**

- a conceptual mechanical design has been finished, need to consider the details to make the design practical
- R&Ds are needed for aerogel machining/fixing, cylinders/endplates manufacturing, light blocking, cabling, cooling, mounting, etc. (2026-2028)
- R&D on how to make high-performance reflectors (mirrors) has started. ESR has some problems for UV wavelength region and large reflecting angles

### ● **Simulation and reconstruction (2026-2028)**

- a basic framework has been set up in CEPCSW, and a first simulation has been done
- more reasonable parameters (optical properties of aerogel, SiPM performance, and detector layout) to be considered, to make the results more reliable
- Reconstruction algorithm need to be developed

## Status and plan of the components (3)

### ● SiPM readout electronics design (2026-2028)

- Need readout electronics for the prototypes and the final detector
- Architecture can base on the current CEPC electronics, but the front-end readout AISC for SiPM may need an altered design from current SIPAC, due to different specs.
- Need people from electronics group to work on this, mentioned to Wei Wei and Miao He, and had a first discussion with Huaishen Li for the technical details. More discussion needed.

### ● Prototype detectors development and test (2027-2030)

- considering to build a proof-of-principle prototype with a few units (e.g. one aerogel block + a few SiPMs) in 2027
- plan to build a relatively large prototype in 2028
- tests and iterations of the prototype in 2029-2030
- CDR in 2028, and TDR in 2030

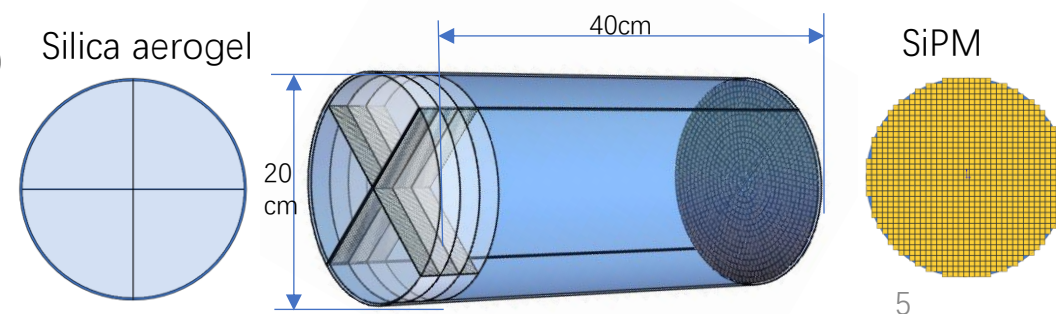

# Some issues (1)

- Current requirements for the Cherenkov detector at CEPC: High momentum PID (3-20 GeV/c) in endcap region ( $9^\circ$ - $20^\circ$ ,  $0.93 < \cos\theta < 0.99$ )

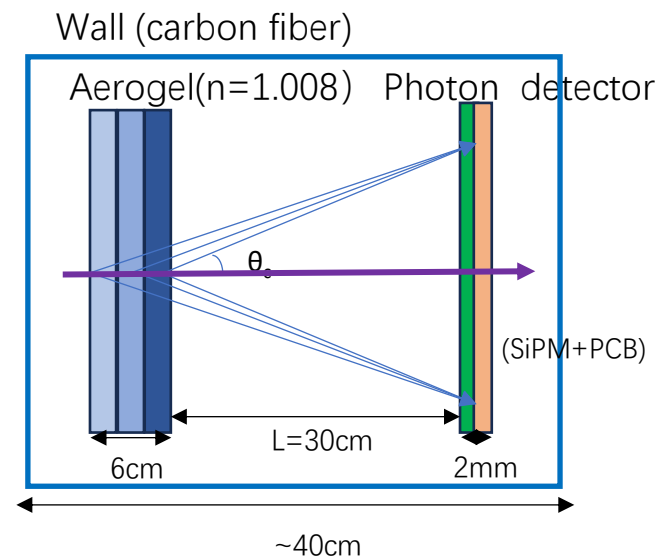
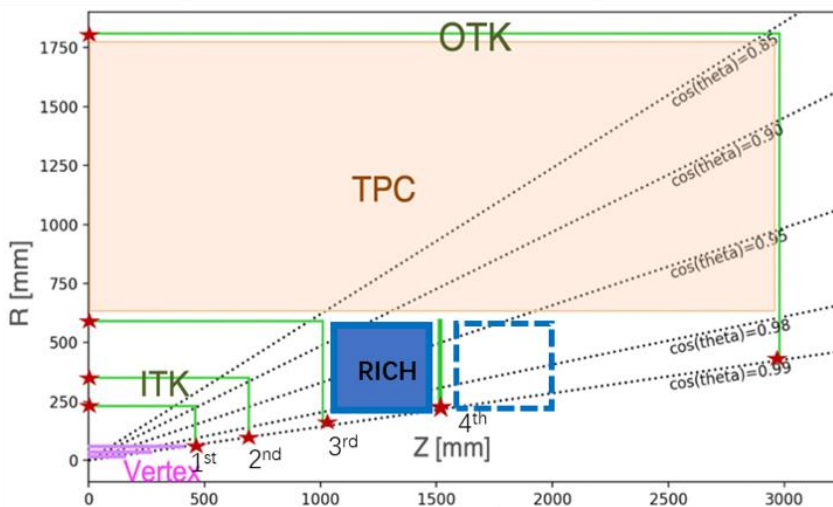
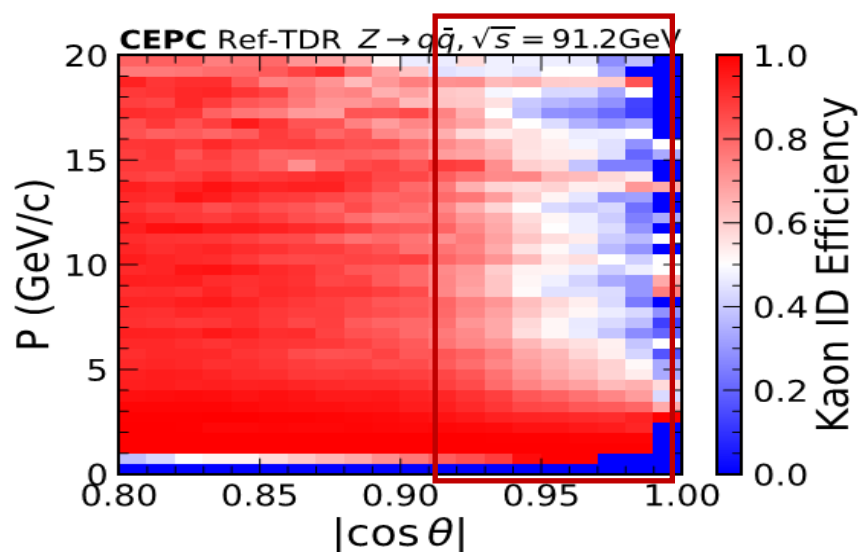

- A study from FCC-ee group shows higher momentum range (up to 40 GeV/c) is needed for flavor physics, e.g.  $B_s^0 \rightarrow D_s^\pm K^\mp$  for CP-violation measurement

- Do we need to cover the momentum range too?

*"Particle identification at FCC-ee", Guy Wilkinson, Eur. Phys. J. Plus (2021) 136:835*

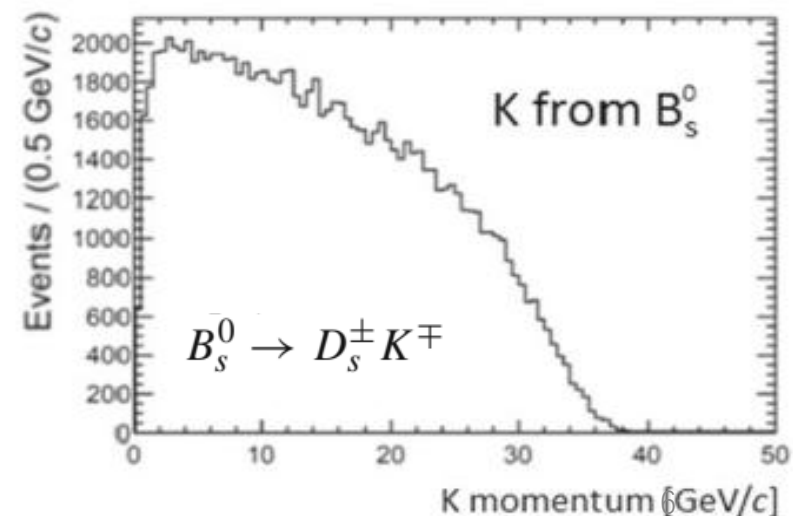

## Some issues (2)

- Manpower shortage at IHEP for Cherenkov detector R&D
  - Hardware: current only two persons (me, and Jian wang (partially working) from mechanical group), no other persons including students;
  - Software: Changru Li and Shengsen Sun, however Changru Li need to take class for his 1<sup>st</sup> year of postgraduate (2026.7 – 2027.7)
  - electronics ?
  - Need some students and postdocs