



Offline Software: Summary from FCC week and Plans

SUN Shengsen
CEPC Day 2026.6.18



↓
FINLAND
HELSINKI

Venue:
Fabianinkatu 33
University of Helsinki
Main Building



FCC Week 2026 Programme Overview

Version: 1.0 Date: 28.05.2026

Day	Monday 8 June	Tuesday 9 June						Wednesday 10 June					Thursday 11 June					Friday 12 June	Day	
Time	Plenary	Parallel 1	Parallel 2	Parallel 3	Parallel 4	Parallel 5	Parallel 6	Plenary	Parallel 1	Parallel 2	Parallel 3	Parallel 4	Parallel 5	Parallel 1	Parallel 2	Parallel 3	Parallel 4	Parallel 5	Plenary	Time
Room	Auditorium (F2044)	Pieni juhlasali (F4050)	Tekla Hultin (F3003)	F3017	F3005	F3020	U3039	Auditorium (F2044)	Pieni juhlasali (F4050)	Tekla Hultin (F3003)	F3017	F3005	F3020	Pieni juhlasali (F4050)	Tekla Hultin (F3003)	F3017	F3005	F3020	Auditorium (F2044)	Room
08:30-09:00	First Morning session	Physics Studies 1	Optics Design and Parameters	Magnet support & alignment	Electricity & Energy Management	FCC Baseline (SRF)	iRIS Project organization	Environment	Physics Software and Computing	Collective Effects	Magnets	RF Points and Cryogenics	Industry Day	Physics Studies 3	FCC-hh & High-field magnets	Machine protection & Availability	Safety	Injector	Summaries	08:30-09:00
09:00-09:30																				
09:30-10:00																				
10:00-10:30	Coffee break	Coffee Break						Coffee Break					Coffee break					Coffee break	10:00-10:30	
10:30-11:00	Second morning session	Detector 1	International Collaboration Board	Vacuum	Geodesy, Transport & Robotics	RF Hardware Development and System Integration for FCC	iRIS WP and alignment 1	Physics studies 2	Detectors 2	Injector overview	Powering	Cooling & Ventilation	Coffee Break	Detectors 3	FCC-hh & High-field magnets	Beam Intercepting devices	Booster overview	RF System Performance and Beam Stability	Summaries	10:30-11:00
11:00-11:30																				
11:30-12:00																				
12:00-12:30	Lunch break						Lunch break					Lunch break					Closing remarks	12:00-12:30		
12:30-13:00	Lunch break	Lunch break						Lunch break					Lunch break					Closing remarks	12:30-13:00	
13:00-13:30		Lunch break						Lunch break					Lunch break						13:00-13:30	
13:30-14:00	Overview by FCC Coordinators	Scheduling, Planning and Resources	Optics Corrections and Tuning	Territorial Dialogue	Integration	MDI 1	iRIS WP and alignment 2	Joint session Physics & Physics Software and Computing	Operation and performance	Industry Day	Joint session Physics Software and Computing & Detectors	MDI 2	Injection & extraction systems	Scientific Advisory Committee	SRF Technology Developments	Injector Machine - Specific Designs and R&D Progress	Closing remarks	13:30-14:00		
14:00-14:30																				
14:30-15:00																				
15:00-15:30	Coffee Break						Coffee Break					Coffee break					15:00-15:30			
15:30-16:00	Coffee break	Systems Engineering and Project-wide integration	Synergies with other projects	Civil Engineering and MATEX	Education, Communication, Outreach, Inreach	EPOL 1	iRIS Executive Board	Nordic-Baltic Perspectives on Big Science and Innovation	EPOL 2	Innovation and Technology	Injector Machine - Specific Designs and R&D Progress	Closing remarks	15:30-16:00							
16:00-16:30																				
16:30-17:00																				
16:30-17:00	Plenary session for Physics, Experiments and Detectors	Poster session						Closing remarks	16:30-17:00											
17:00-17:30																				
17:30-18:00																				
18:00-18:30	Welcome reception	Early Career Professionals	Conference dinner						Closing remarks	18:00-18:30										
18:30-19:00																				
19:00-19:30																				
19:30-20:00																				
20:00-20:30	Conference dinner						Closing remarks	20:00-20:30												
20:30-21:00																				
21:00-21:30																				
21:30-22:30																				

Parallel Session PED#3: Physics Software and Computing 1/1			
Date and time:	Wednesday, June 10, 8:30-10:00		
	chair person:	Lange, David (TBC)	Princeton U. & CERN
talk 1	Towards an FCC computing Model (15'+3')	Guerrieri, Giovanni	CERN
talk 2	MC production tools and schedule (15'+3')	Kontaxakis, Pantelis	U. Geneva
talk 3	key4hep - ML / Threading (15'+3')	Carceller, Juan Miguel	CERN
talk 4	ACTS and FCC (15'+3')	Gessinger, Paul	CERN
talk 5	Leveraging synergies between CEPCSW and FCCSW (15'+3')	Sun, Shengsen	IHEP
Parallel Session PED#6: Joint session Physics & Physics Software and Computing			
Date and time:	Wednesday, June 10, 13:30-15:00		
	chair person:	Selvaggi, Michele (TBC)	CERN
talk 1	Analysis Tools and Visualisation (15'+3')	Smiesko, Juraj	CERN
talk 2	MC Generators Status and Plans (15'+3')	Siodmok, Andrzej	Jagiellonian U.
talk 3	High Level Reco Status and Plans (tracking, vertexing, flav tagging)	De Vita, Andrea	INFN Padova
talk 4	High Level Reco Status and Plans (PFlow, tau reco, physics objects)	Ko, Sanghyun	CERN
talk 5	LEP data - status and plans (15'+3')	Fatehi, Apranik	CERN
Parallel Session PED#9: Joint session Physics Software and Computing & Detectors			
Date and time:	Thursday, June 11, 13:30-15:00		
	chair person:	Francois, Brieuc (TBC)	CERN
talk 1	Geometry, simulation talk (15'+3')	Beirer, Joshua	CERN
talk 2	Muon system optimization for displaced signatures (15'+3')	Ali, Mahmoud	U. Bologna
talk 3	Overview of digitizers and local reco (15'+3')	Einhaus, Ulrich	KIT
talk 4	Silicon sensor digitization (15'+3')	Dilg, Jona	DESY
talk 5	Automatic detector performance based validation (15'+3')	Loeschcke Centeno, Andreas	U. Sussex

Summary page of “Leveraging Synergies between CEPCSW and FCCSW”

Thanks Weidong for providing material!
Thanks Joao and Miao for suggestions!

- CEPCSW and FCCSW have the common foundation, Key4hep, and the collaboration ensures long-term sustainability and maximizes the impact of limited HEP software resources
- CEPCSW has enabled comprehensive studies of CEPC detector designs and physics potential
 - Full simulation has contributed to evaluating material budget, testing different configuration ...
 - Based on full simulation, some fast simulations enabling large-scale sample production with reduced CPU cost
 - iLCSoft-based tracking algorithms have been optimized for performance studies, an ACTS-based tracking chain is developed for gaseous tracker
 - dN/dx reconstruction algorithms for DC and TPC based on deep learning shows good performance
 - Development of CyberPFA, a particle-flow algorithm using advanced techniques
 - Automated validation system integrating CI/CD, physics checks, and centralized monitoring
- Ongoing activities include
 - Migration to the latest EDM4hep/Key4hep, multithreading implementation, deployment of the Gaussino simulation framework, and integration of the DAQ system with offline software workflows
- **Looking forward to deeper collaboration with FCCSW!**

Kiitos!
Thank you!

Physics Software



Juan Miguel Carceller
Juraj Smiesko

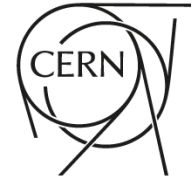

- ❑ Most results shown this week were made possible thanks to recent physics software developments
 - ❑ **FCCAnalyses used by most analyzers**
 - ❑ Plan to use it as a hub for **flagship physics analyses**, kept **maintained** and ready to be ran for any detector for **optimization and performance benchmarking**
 - ❑ **Support for LEP data analyses workflows** upcoming
 - ❑ The common software philosophy is gaining traction
 - ❑ Ported by **Key4hep**, now **mature**, keeps improving
 - ❑ Reached a **critical mass of users**, adoption keeps growing (e.g. DRD's)
 - ❑ **CEPC** froze the Key4hep version to write a TDR, now catching up to be back in the game
 - ❑ We will try to **ensure that synergies can be exploited**
 - ❑ CLD ported almost all its **ILCSoft originating code to Key4hep 'native'**
 - ❑ ILD starts to do the same
- ❑ To improve community efficiency: **don't work isolated, reach out to people/[forum](#), use the common tools, develop in the common frameworks, upstream your work**

Parallel Session PED#3: Physics Software and Computing 1/1			
Date and time:	Wednesday, June 10, 8:30-10:00		
	chair person:	Lange, David (TBC)	Princeton U. & CERN
talk 1	Towards an FCC computing Model (15'+3')	Guerrieri, Giovanni	CERN
talk 2	MC production tools and schedule (15'+3')	Kontaxakis, Pantelis	U. Geneva
talk 3	key4hep - ML / Threading (15'+3')	Carceller, Juan Miguel	CERN
talk 4	ACTS and FCC (15'+3')	Gessinger, Paul	CERN
talk 5	Leveraging synergies between CEPCSW and FCCSW (15'+3')	Sun, Shengsen	IHEP
Parallel Session PED#6: Joint session Physics & Physics Software and Computing			
Date and time:	Wednesday, June 10, 13:30-15:00		
	chair person:	Selvaggi, Michele (TBC)	CERN
talk 1	Analysis Tools and Visualisation (15'+3')	Smiesko, Juraj	CERN
talk 2	MC Generators Status and Plans (15'+3')	Siodmok, Andrzej	Jagiellonian U.
talk 3	High Level Reco Status and Plans (tracking, vertexing, flav tagging)	De Vita, Andrea	INFN Padova
talk 4	High Level Reco Status and Plans (PFlow, tau reco, physics objects)	Ko, Sanghyun	CERN
talk 5	LEP data - status and plans (15'+3')	Fatehi, Apranik	CERN
Parallel Session PED#9: Joint session Physics Software and Computing & Detectors			
Date and time:	Thursday, June 11, 13:30-15:00		
	chair person:	Francois, Brieuc (TBC)	CERN
talk 1	Geometry, simulation talk (15'+3')	Beirer, Joshua	CERN
talk 2	Muon system optimization for displaced signatures (15'+3')	Ali, Mahmoud	U. Bologna
talk 3	Overview of digitizers and local reco (15'+3')	Einhaus, Ulrich	KIT
talk 4	Silicon sensor digitization (15'+3')	Dilg, Jona	DESY
talk 5	Automatic detector performance based validation (15'+3')	Loeschcke Centeno, Andreas	U. Sussex

Joshua Beirer



FCC-ee Proposed Detectors

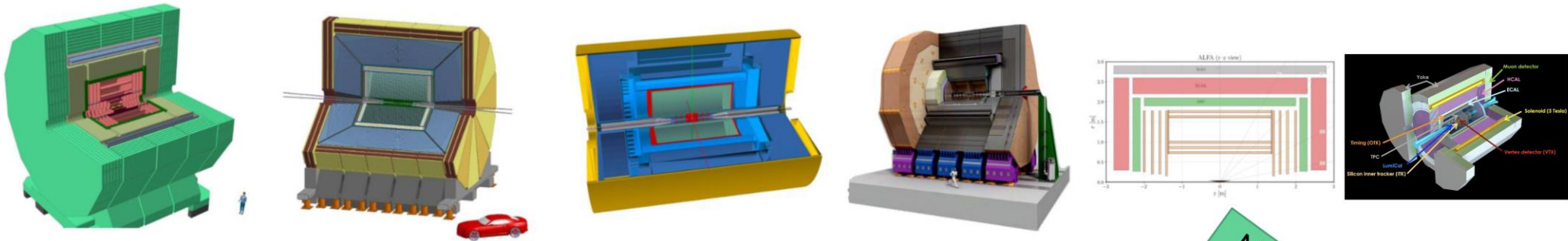

New!

	CLD	IDEA	ALLEGRO	ILD	ALFA <i>emerging</i>	AGORA (CEPC ref. det.) Advanced Glass Optimized Research Apparatus
Vertex	Si	MAPS (ITS-3-like)	MAPS (ITS-3-like)	Si (CLD-evolved)	MAPS (ITS-3-like)	
Tracker	Full Si	Drift Chamber	DCH / Straw / SciFi	Si + TPC	All MAPS	
ECAL	Si-W	Crystals	Noble Liquid (LAr)	Si-W (granular)	Grainita	
HCAL	Scint. sampling	Fibre DR	TileCal (steel/scint)	Scint. or RPC	Fibre DR + iron yoke	
Muon	RPC iron yoke	uRWELL	<i>SimpleCylinder driver</i>	Sc. tagger in iron yoke	<i>tagger (tech TBD)</i>	
PID	<i>ARC (option)</i>	tracker (DCH dN/dx)	tracker	tracker	ARC	
B-field	2 T	2 T (3 T HTS R&D)	2 T	2 T	3 T	

Sub-system	Technologies
Beam pipe	Beryllium, ϕ 20 mm
LumiCal	Silicon tracker + LYSO crystals
Vertex	Si Pixels: CMOS MAPS+stitching
Inner tracker (ITK)	Si Pixels: CMOS MAPS 55-nm
Gas detector	TPC with high granularity
Outer tracker (OTK)	AC-LGAD \rightarrow TOF
ECAL	4D transverse crystal bars
HCAL	Glass scintillator, SiPM + Fe
Magnet	LTS Solenoid
Muon	Plastic scintillator bars, SiPM
TDAQ	Conventional
Back-end electronics	Common

Physics Software & Computing

B. François
D. Lange

PSC groups

Analysis and visualization
J. Smiesko, TBD

MC generators
S. Batthacharya, S. Plaetzer, L. Portales, A. Price, A. Siódmok

High-level reconstruction
D. Garcia, L. Herrmann, A. Zaborowska

Documentation and trainings
M. Hernandez Villanueva, A. Moreno

Core SW/Key4hep
J.M Carceller, T. Madlener

Interaction region, beam bckg
A. Ciarna, J. Eysermans, A. Koulouris

Geometry, simulation
A. Loeschcke Centeno, G. Tassielli

Computing resources
G. Guerrieri, L. Herrmann

MC production, GRID tools
P. Kontaxakis, J. Smiesko

DIGI-RECO SW
U. Einhaus, S. Ko

Physics Studies

P. Azzi
J. de Blas
D. d'Enterria
M. McCullough
M. Selvaggi

Physics groups

BSM
J. Davighi, R. Gonzalez-Suarez, G. Polesello, S. Renner

EW
J. Bendavid, M. Defranichis, J. Eysermans,
M. Riembaud, A. Vicini

FCC-hh
S. Banerjee, B. Stapf, A. Taliercio, S. Williams, T. You

Flavour
G. Isidori, J.F. Kamenik, Z. Ligeti, A. Lusiani, S. Monteil

Charm
M. Bertemes, G. Hiller, N. Jurik, J. Kamenik, D. Mitzel

CCP
C. Agapopoulou, A. Juttner, M. Prim, D. Robinson, R. van Tonder, X. Zuo

CPV
A. Bragagnolo, L. Dufour, M. Kenzie, S. Schacht, M. Veronesi, J. Zupan

Rare
W. Altmannshofer, M. Bordone, T. Humair, R. Qualligiani, N. Rout, E. Smith

TauEW
M. Cepeda, R. Mader, A. Martens, E. Passemar, O. Sumensari, TBD

Global fits & EFT
L. Brenner, A. Gilbert, L. Mantani, V. Miralles

Higgs
G. Cacciapaglia, M. Delmastro, R. Gröber, A. Li, A. Mehta

Precision calculation
J. Glusza, M. Zaro

QCD and $\gamma\gamma$
A. Badea, S. Kluth, R. Poncelet, G. Stagnitto

Top
G. Durieux, J. Reuter, C. Schwanenberger, X. Zuo

Detector Concepts

M. Dam
M.A. Pleier
NN

Subsystem studies

Calorimetry
M. Lucchini, L. Masetti, N. Morange, H. Yoo

Luminometry
TBA

Magnet
TBA

Muons
TBA

TDAQ
Z. Demiragli, T. Wengler

Tracker
V. Cairo, G. Iakovidis

Concept studies

ALFA
D. Abbaneo

ALLEGRO
M. Aleksa

CLD
J. Zhang

IDEA
P. Giacomelli

ILD
T. Behnke

...
TBD

Giovanni Guerrieri
Pantelis Kontaxakis



Computing Model and MC Productions

- ❑ Generating FCC-ee MC samples at such high orders will be very **CPU intensive**
- ❑ A **robust and flexible computing model** will be needed (WLCG-like)
- ❑ It is actually already needed now
 - ❑ **Full Sim based physics reach estimates** exceeds the computing that a single institute can provide (+ detector optimization campaigns, + BIB)
 - ❑ We target a **common computing model** across experiments → better be **ready** (and good) **before collaborations** are formed
- ❑ Current implementation: Dirac workload management, Rucio data management
 - ❑ Up and running, **many sites joining the FCC VO**
- ❑ First **real scale production** expected by the end of **2026**
 - ❑ Winter23 Delphes reproduced + CLD selected samples
 - ❑ Other detector concepts will follow as they become mature

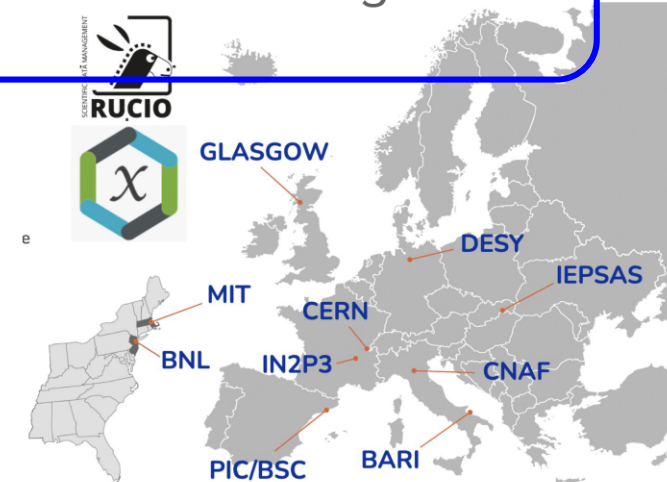
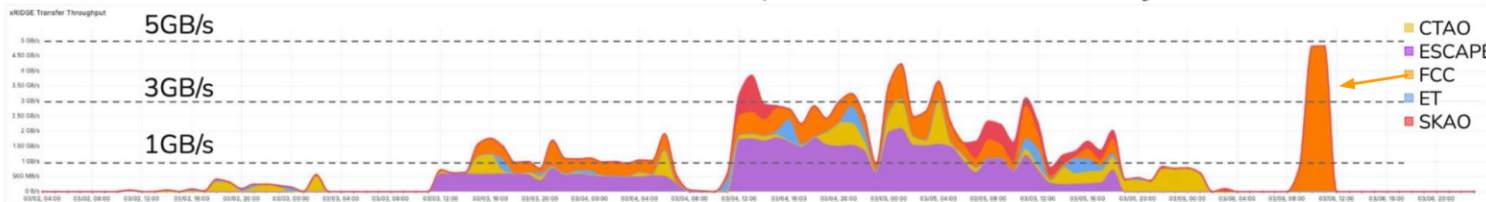

Jona Dilg
 Joshua Falco Beirer
 Sanghyun Ko
 Andrea De Vita
 Uli Einhaus



Status of Detailed Simulation

- ❑ Most **physics groups** now **need more detailed simulations** to move forward
- ❑ **CLD detailed simulation is ready to be used for physics analyses**
 - ❑ Physics performance can surely be improved, **need feedback from analyzers**
- ❑ ILD@FCC-ee will follow soon, ALLEGRO and IDEA are implementing their RECO, ALFA is just starting, AGORA has to be better integrated with modern Key4hep
- ❑ BIB impact must be quantified → implementing detailed digitizers

❑ **If you need Full Sim**, don't wait that it happens, **join the effort!**

- ❑ Testing it already helps
- ❑ Many people are there to provide support

First version of IDEA tracking just finished! Already meets requirement (Andrea & Arina)

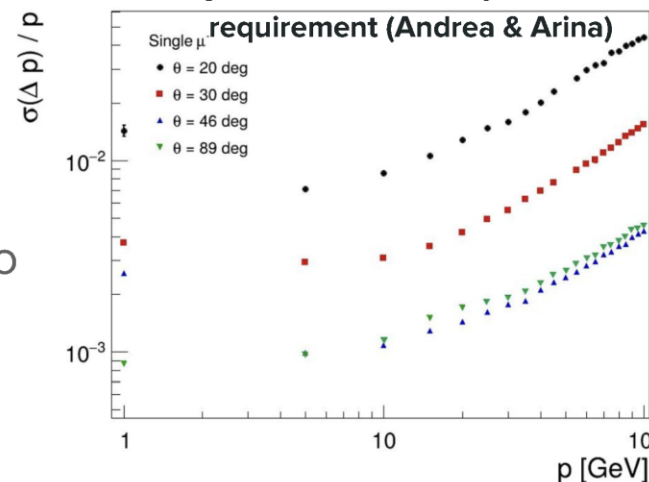

FCC-ee ALLEGRO

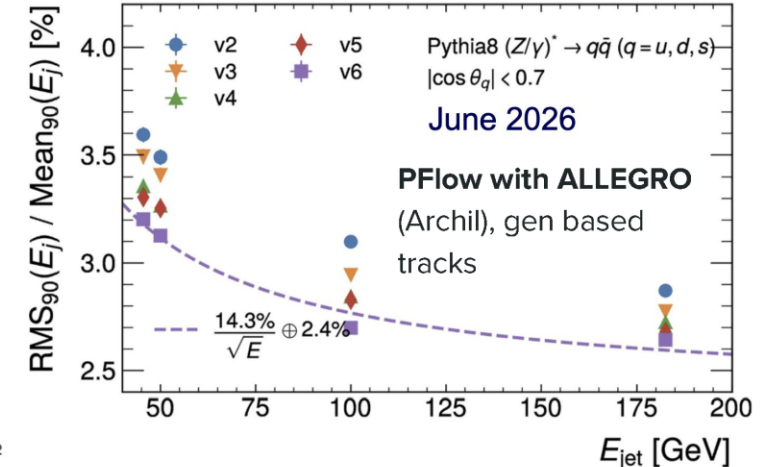



Proposed scale, schedule and milestones

A phased plan to deliver immediate samples while consolidating the production service

Production roadmap

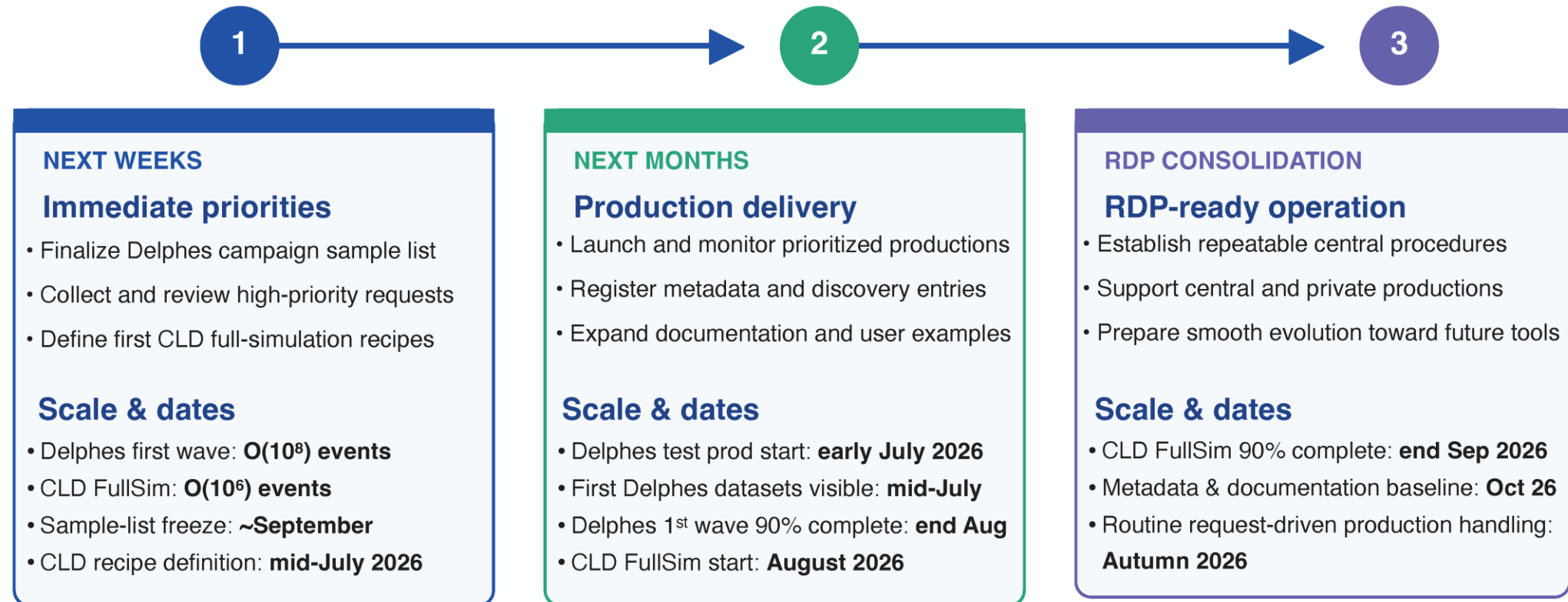

“Geometry and Simulation: Overview of Status and Plans”, Joshua F. Beirer

- FCC Geometry and simulation software designed to be **flexible and shared** across experiments as much as possible
- Detector concept implementations in k4geo **gaining maturity**, allowing ever more realistic performance optimization studies
- Many new sub-systems emerging in the Reference Design Phase (**HTS solenoid, GRAiNITA, SciFi, etc.**)
- Good progress in developing **robust physics and performance validation infrastructure**
- Input from detector R&D and beam tests essential to **validate and tune full simulation** configurations
- **Collaboration** with DRD efforts, detector (proto) collaborations as well as core software projects will be crucial



“**Semiconductor tracker digitisers**”, Jona Dilg

“**Digitisation & Low Level Reconstruction Overview**”, Uli Einhaus

Precis VXD modeling, tested and first results

	Projection-based	Lookup table-based
Design goal	Simple usage, minimal free parameters	Maximum precision
Target	General usage	Detector layout optimisation; pixel hit-rate estimation
Optimal sensor	Tall, uniform pixel geometries	Thin, complicated pixel geometries
Requirements	Few, predefined numbers to describe charge transport	Pre-calculated lookup tables from sensor R&D simulations
Current status	Fully usable, tested with CLD	Merge to stack in progress, used in BIB-studies
Validation	Compared to previous digitiser, possibly on data in future	Cluster size validation on data planned
Timing	Basic Gaussian smearing	Basic Gaussian smearing

- Silicon sensor digitisation: [next talk](#) by J. Dilg
- Gaseous tracker & PID
 - Drift chamber
 - Straw tubes
 - Time projection chamber
 - ARC
 - TOF
- Calorimeter
 - SiPM (for dual readout)
 - LAr
 - Grainita
 - HiGran (SiW ECal, AHCAL, SDHCAL)
- High-level reco: [Tracking](#) by A. de Vita and [Particle Flow & PID](#) by S. Ko

PID: Technologies



Hadrons identified by their mass, in turn determined by combining momentum and velocity.
Momentum inferred from radius of curvature in magnetic field, need to measure velocity.

Various technologies allow to identify hadrons in different momentum ranges

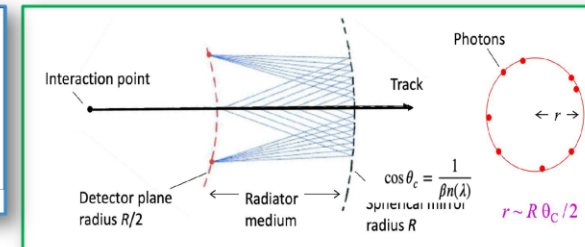
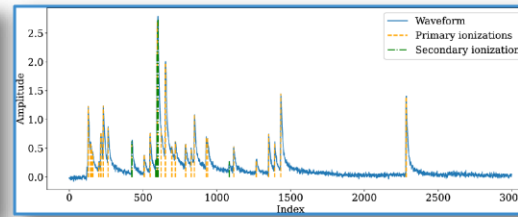
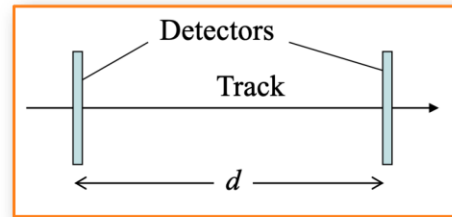
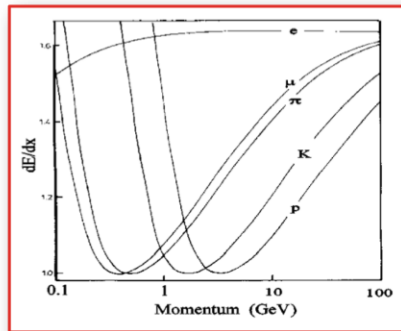
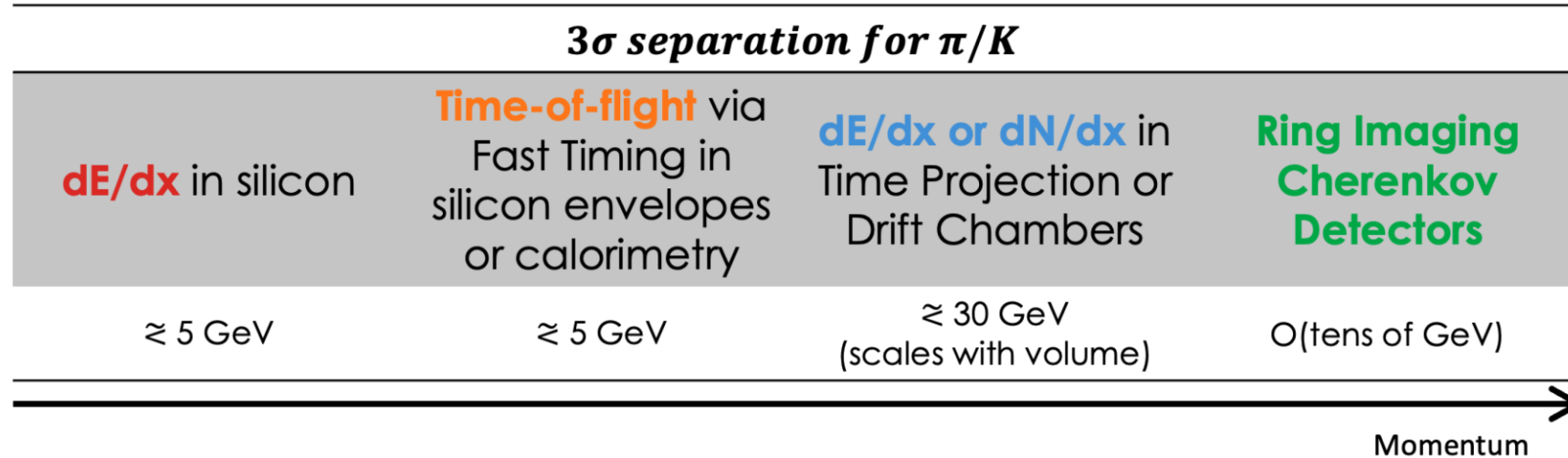

“Tracking & Particle Identification for FCC-ee” (Detector), Valentina Cairo, George Iakovidis

PAPER • OPEN ACCESS

Enhancing particle identification in helium-based drift chambers using cluster counting: insights from beam test studies

W. Elmetenawee, M. Abbrescia, M. Anwar, C. Caputo, G. Chiarello, A. Corvaglia, F. Cuna, B. D’Anzi, N. De Filippis, F. De Santis, M. Dong, E. Gorini, F. Grancagnolo, S. Grancagnolo, F.G. Gravili, M. Greco, K.F. Johnson, S. Liu, M. Louka, P. Mastrapasqua, A. Miccoli, M. Panareo, M. A. Taliercio, G.F. Tassielli, A. Ventura, L. Wu and G. Zhao [Hide full author list](#)

Published 26 November 2025 • © 2025 The Author(s)

[Journal of Instrumentation](#), Volume 20, November 2025

Citation W. Elmetenawee et al 2025 *JINST* 20 P11019

DOI 10.1088/1748-0221/20/11/P11019

Article PDF



dN_{cl}/dx measurements

- Several test beams with prototype drift cells to experimentally assess and optimize the performance of the cluster counting/timing techniques covering large $\beta\gamma$ range
- Several improvements achieved with improved algorithms
- Similar effort ongoing with the straw tubes prototype, electronics developed for cluster counting, analysis is ongoing

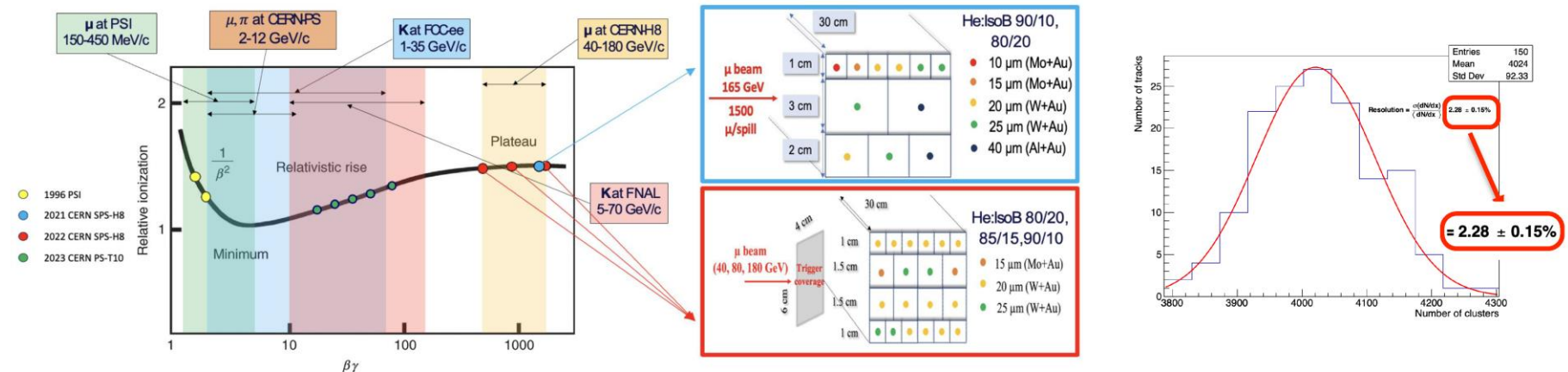

W. Elmetenawee et al 2025 *JINST* 20 P11019

“High Level Reconstruction Status”

Andrea De Vita

What Has Been Done...

Track Finding

- CLD implements **Conformal Tracking** with MarlinWrappers.
- IDEA relies on **Geometric Graph Track Finding**.
- ALLEGRO adapts the CLD implementation for **Vertex + SiWr hits**.
- TPC-Seeded track finder for **ILD@FCC**.

Track Fitting and Vertexing

- CLD uses a **Kalman filter** for track fitting following the Conformal Tracking step, and it relies on **LCFIPlus** for vertex reconstruction.
- IDEA implements **Deterministic Annealing Filter** thanks to the **Genfit2** implementation.
- A fitting algorithm has been implemented for ILD, including vertexing with **LCFIPlus**.

...What Is Yet to Come

Track Finding

- Introduction of a **Gaudi-native** implementation of **Conformal Tracking**.
- Adaptation of **ACTS** for the CLD detector.
- Ongoing efforts to develop a **heuristic track finder** for wire detectors.
- New **hybrid track finder** for ILD under development.

Track Fitting and Vertexing

- Validation** and further development of **Genfit2** and **testing detector agnosticity** using ALLEGRO.
- Delphes-based vertexing** will be implemented for both IDEA and ALLEGRO.
- Evaluation of **Conformal Tracking performance** on ALFA.

“High Level Reconstruction Status” Sanghyun Ko

	CLD	ILD	IDEA	ALLEGRO
PandoraPFA	✓ [link]	✓ [link]	Ongoing [link]	Ongoing [link]
ML PF	✓ HitPF [link] MaskFormer [link]	Ongoing [link]	Planned	Started (Giovanni & Rami)
PID	Ongoing (ARC) [link]	✓ TPC + ToF [link]	Ongoing (dN/dx) [link]	
Jet flavor tagging	✓ [link]	(performed in the context of ILC [link])	Planned	Planned
π^0 ID		(from 2015 [link])		Ongoing [BDT][Transformer]
Tau	Ongoing [link]	(from 2015 [link])	Planned (previous “standalone” study with option 1 [link])	Planned

1) full-simulation only

2) consider studies conducted with tools available in the central framework (or plan to be integrated)

3) ALFA to be appeared once the geometry is ready

A Preliminary List

- Expression of synergies can be exploited with CEPCSW
- Full(detailed) simulation of CLD is ready, ILD is follow soon, ALLEGRO and IDEA are implementing their RECO, ALFA is start
- Beam induced background
- Geometry/Digitization → more like work with(for) somebody else
- dE/dx or dN/dx in time projection or drift chamber
- High Level Reconstruction
- Visualisation: Phoenix
- AI-driven?

Precision Calculation, MC Generators

Matteo Marcoli
Andrzej Siodmok
Janusz Gluza



To fully **exploit** the FCC-ee **physics potential**, important **progress** has to be made on **theoretical predictions**

□ NNLO-accurate results for $e^+e^- \rightarrow 4$ jets now available!

□ Code [publicly available](#) (long term preservation!)

□ Next: 3 jets at N³LO

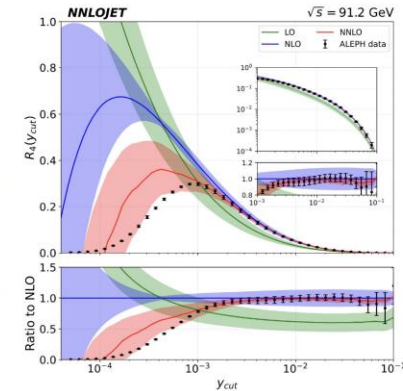
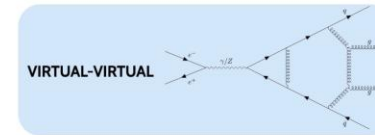

□ Much more needs to be done

□ Unfolding techniques, full two-loop corrections $e^+e^- \rightarrow W^+W^-, ZH, VVH, \dots$

□ “No show-stopper identified”, matter of work

□ Also need higher order MC generators

□ Creating a community focused on FCC-ee

□ Preserve the know-how over 30 years!

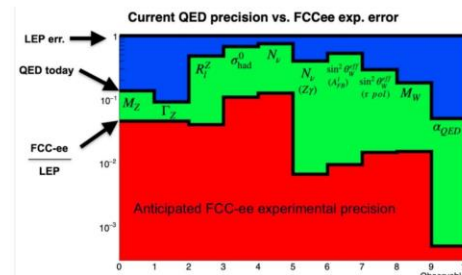

Table 4.2: Wish-list for calculations of missing higher-order perturbative QCD $\mathcal{O}(\alpha_s^n)$ and/or EW $\mathcal{O}(\alpha^n)$ to match the expected experimental uncertainty at future e^+e^- and ep colliders.

Observable	Missing higher-order & power-suppressed corrections
Hadronic Z width	$\mathcal{O}(\alpha_s^2), \mathcal{O}(\alpha_s^3), \mathcal{O}(\alpha^3), \mathcal{O}(\alpha_s \alpha^2), \mathcal{O}(\alpha_s^2 \alpha^2)$
Hadronic W width	$\mathcal{O}(\alpha_s^2), \mathcal{O}(\alpha^2), \mathcal{O}(\alpha_s^2 \alpha)$
Hadronic τ width	$\mathcal{O}(\alpha_s^2)$
Hadronic event shapes (Z, W, H decays)	N ³ LO differential, N ^{3,4} LL resummation, power corrections
Inclusive jet rates	3-jet cross-sections at N ³ LO, 4-jets at N ² LO, 5-jets at NLO
Lattice QCD results	$\mathcal{O}(\alpha_s^2)$ β -function; $\mathcal{O}(\alpha_s^2)$ heavy quark decoupling; $\mathcal{O}(\alpha_s^2)$ static potential
(α_s extr.; quark masses m_c, m_b)	$\mathcal{O}(\alpha_s^3)$ lattice perturbation theory matching (lattice coupling to α_s^{MS} etc.)
$\sigma(e^+e^- \rightarrow W^+W^-)$ vs. \sqrt{s}	EW N ² LO; $\mathcal{O}(\alpha^2)$; Mixed EW-QCD; $\mathcal{O}(\alpha_s \alpha^2), \mathcal{O}(\alpha_s^2 \alpha)$
$\sigma(e^+e^- \rightarrow t\bar{t})$ vs. \sqrt{s}	NRQCD; $\mathcal{O}(\alpha_s^2)$; Non-resonant; $\mathcal{O}(\alpha_s^2)$ differential; QED; $\mathcal{O}(\alpha^3)$ at NNLL
$H \rightarrow b\bar{b}$ width	N ² LO ($m_b \neq 0$); N ² LO differential ($m_b = 0$)
$H \rightarrow g\bar{g}$ width	N ³ LO (heavy-top limit), N ⁴ LO ($m_t \neq 0$); N ⁴ LO differential, N ³ LO differential ($m_t \neq 0$)
MC simulations for $e^+e^- \rightarrow X$ processes	N ^{2,3} LO matched to N ^{2,3} LL PS. Per mille control of non-pQCD effects (hadronization, CR, ...)
$ep \rightarrow$ hadrons (PDF and α_s determ.)	N ^{3,4} LO evolution equations and inclusive cross-sections
$ep \rightarrow$ jets (α_s determ.)	N ³ LO cross-sections

Andreas Leoschke Centeno
Juan Miguel Carceller
Joshua Falco Beirer



Robust Framework on the Long Run

- ❑ Detector software developments are in full swing (good), but we must **avoid breaking things** along the way
- ❑ Implemented **several levels of protections** for healthy code evolution
 - ❑ CI tests: the **code still compiles**
 - ❑ Physics based validation: **avoid unexpected physics alterations**
 - ❑ Infrastructure in place, please populate it with your “simulation quality monitoring” plots!
 - ❑ Continuous computing performance benchmarking (CPU, memory): **workflows remain fast and memory effective**
 - ❑ Daily, but also upon pull requests (planned)

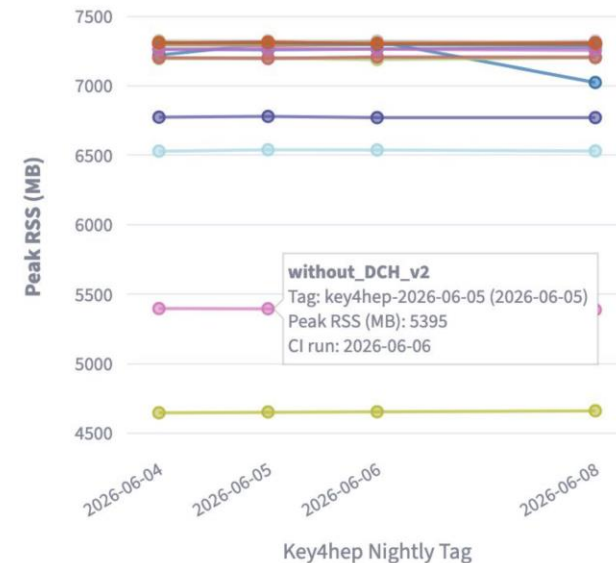
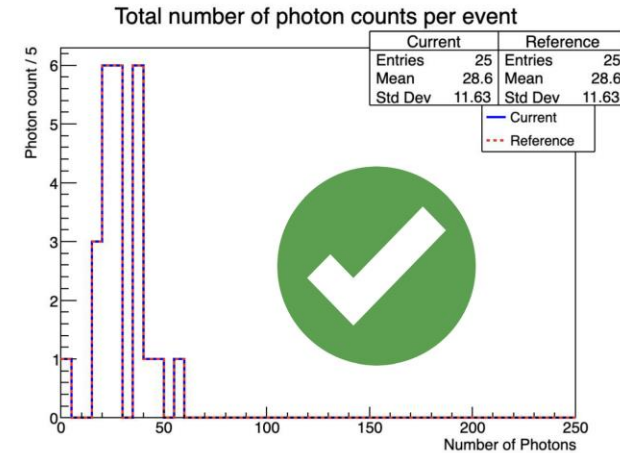



(T?)DAQ at FCC-ee

- ❑ **No show-stopper** from the **TDAQ** point of view, but need to choose the strategy (trigger?)
- ❑ **Too early to design** a TDAQ system now: many uncertainties & technology will evolve
 - ❑ Try to **understand** the experimental **environment** (e.g. occupancies)
 - ❑ **Mitigate** what can/should be mitigated (e.g. **synchrotron radiation**)
 - ❑ Understand the **trade offs** and their impacts
 - ❑ Selection uncertainty vs material budget vs storage capacity vs operational requirements
- ❑ Can we get the data out within the material and power budgets?
 - ❑ Hardware developments ongoing in DRD7
 - ❑ Will try to converge on **common solution** across experiments

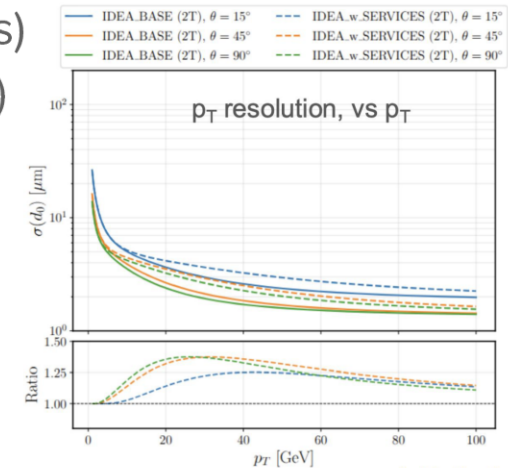

A. Koulouris

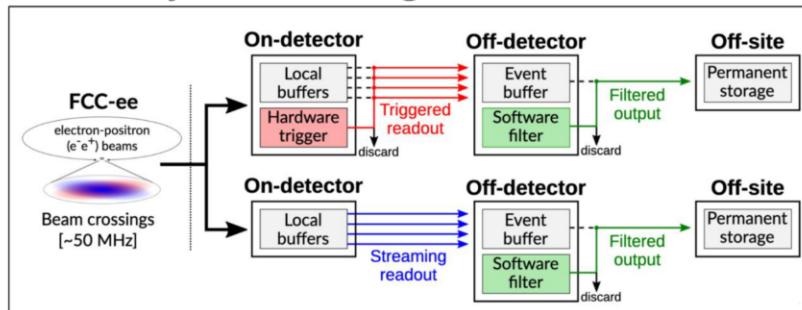

← Less bandwidth? less material? and power required

← No added uncertainties on event selection

