



Istituto Nazionale di Fisica Nucleare

INFN: an established Italian research and innovation excellence as well as a solid bridge among EU and China

Prof. Marco Maggiora

Director of the IHEP-INFN Joint Laboratory (I2JL)

INFN

has been founded in 1951

with a long and prestigious
history that descends by

Enrico Fermi and the

Boys of Via Panisperna



**Pushing beyond the
frontiers of
knowledge**

Big Bang secrets



Develop

new frontier technologies



The mission

**Investigate together
with young people and
researchers around the
world**



Train

the scientists and engineers of
tomorrow



The challenge

understanding the Universe in the early moments after the Big Bang

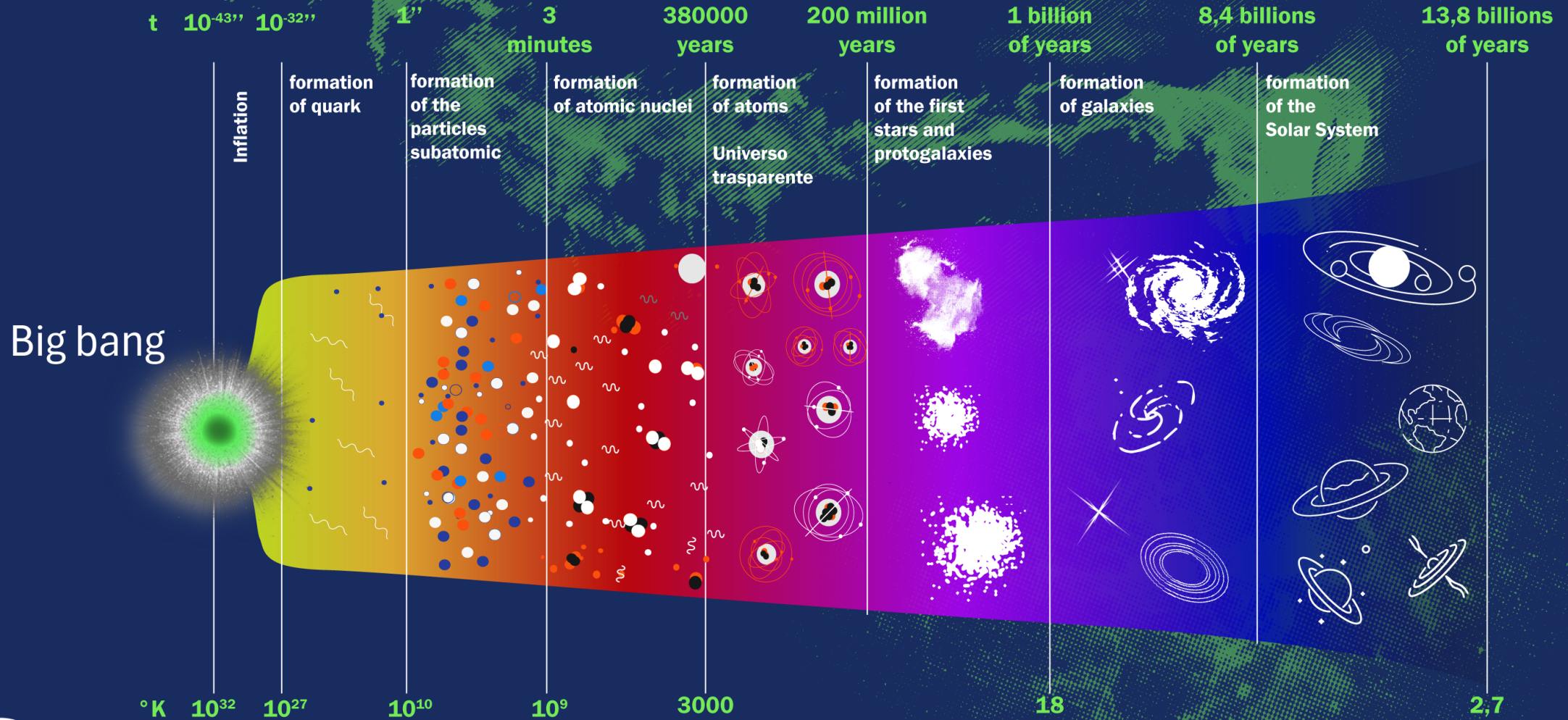

INFN organizational chart

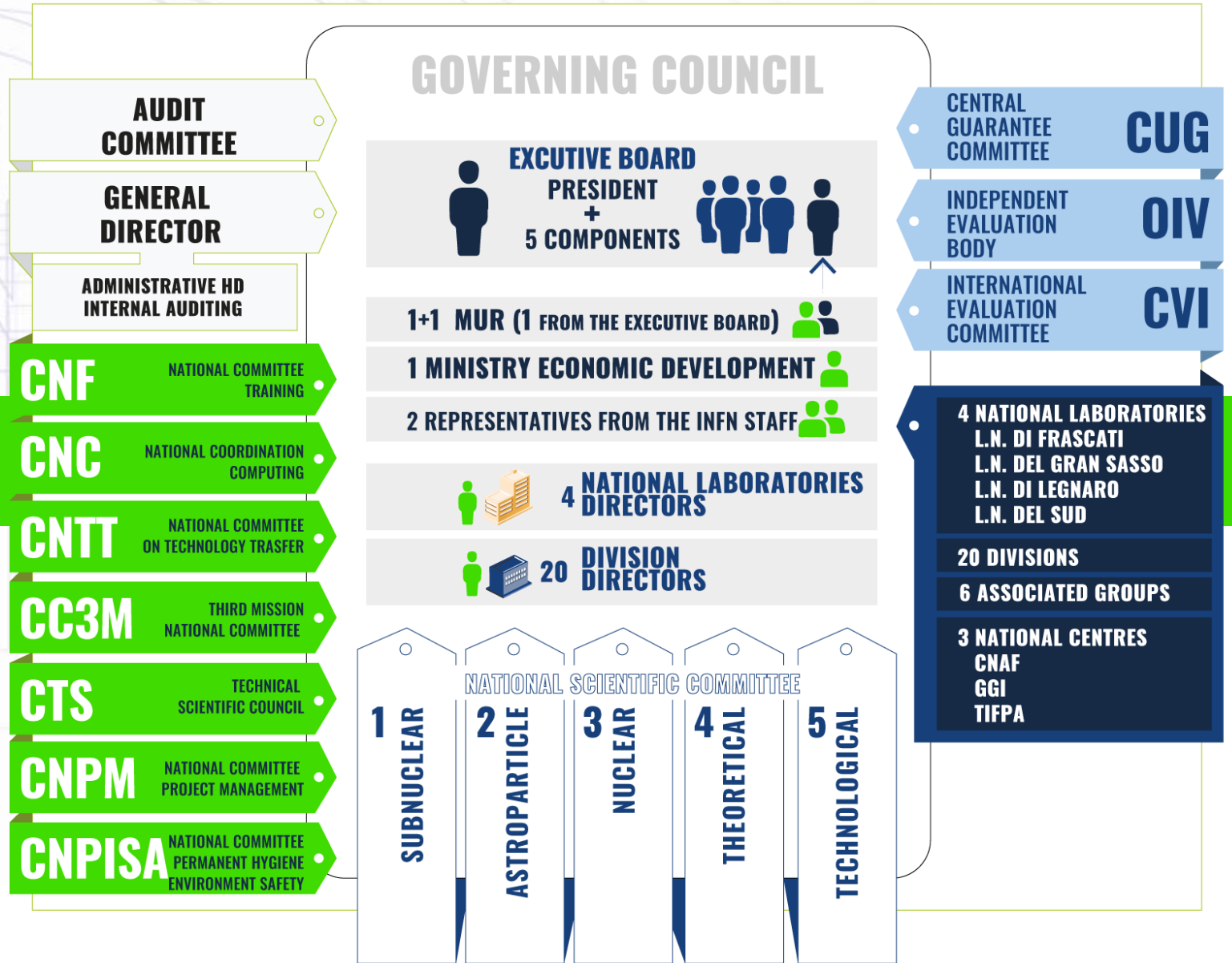

The 5 lines of research and the National Scientific Commissions



CSN1

**SUBNUCLEAR
Physics**



CSN2

**ASTROPARTICLE
Physics**



CSN3

**NUCLEAR
Physics**



CSN4

**THEORETICAL
Physics**



CSN5

**TECHNOLOGICAL
Research**

- Laboratori Nazionali
National Laboratories
- Sezioni
Division
- Gruppi associati
Associated groups
- Centri Nazionali e Scuole
National Centres and Schools
- Consorzi
Consortia



4 National laboratories

20 Divisions

6 Associated Groups

3 National Centres and Schools

1 Consortia

Infrastructures

4 National Laboratories

National Laboratories of Legnaro

Gran Sasso National Laboratory

National Laboratories of Frascati

National Laboratories the South

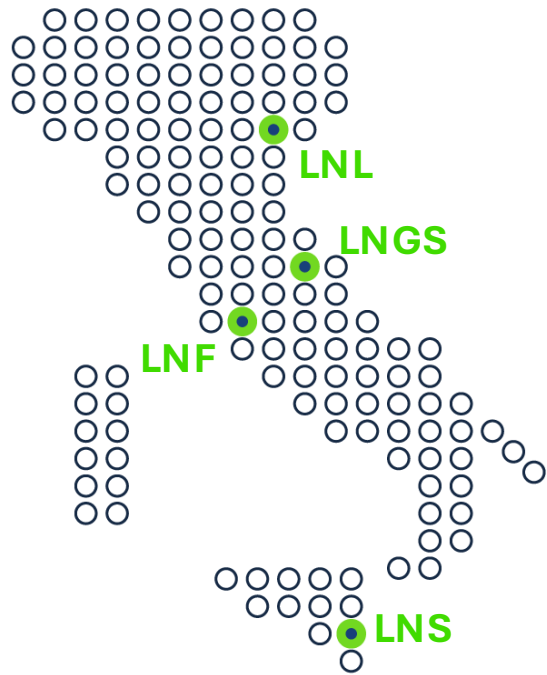

INFN facilities

3 National Centres

Trento Institute for Fundamental Physics and Applications

Galileo Galilei Institute

National Centre for Research and Development on Information and Communication Technologies

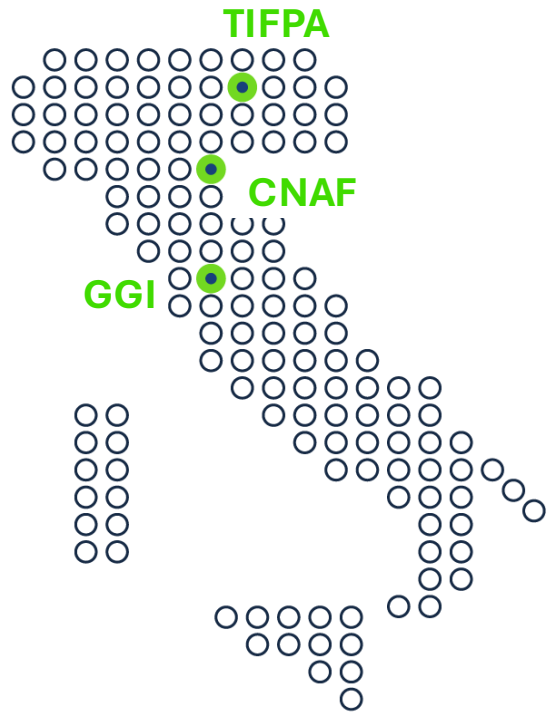

Infrastructures

1 Consortia

EGO

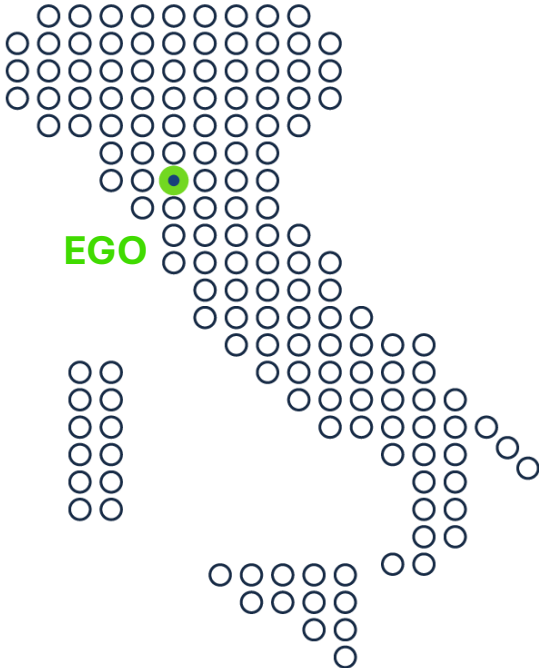

An international DNA



CERN
Geneva, Switzerland

An international DNA



Fermi National Accelerator Laboratory
Batavia, Illinois, USA

An international DNA



Synchrotron-Light for Experimental Science and Applications in the Middle East (SESAME) Allan, Jordan

An international DNA



Super-Kamiokande
Mount Ikeno, Japan

An international DNA



Kilometer Cube Neutrino Telescope (KM3NeT)
Portopalo di Capo Passero, Italy
Toulon, France

An international DNA



**Pierre Auger Observatory
Pampa Amarilla, Argentina**

An international DNA

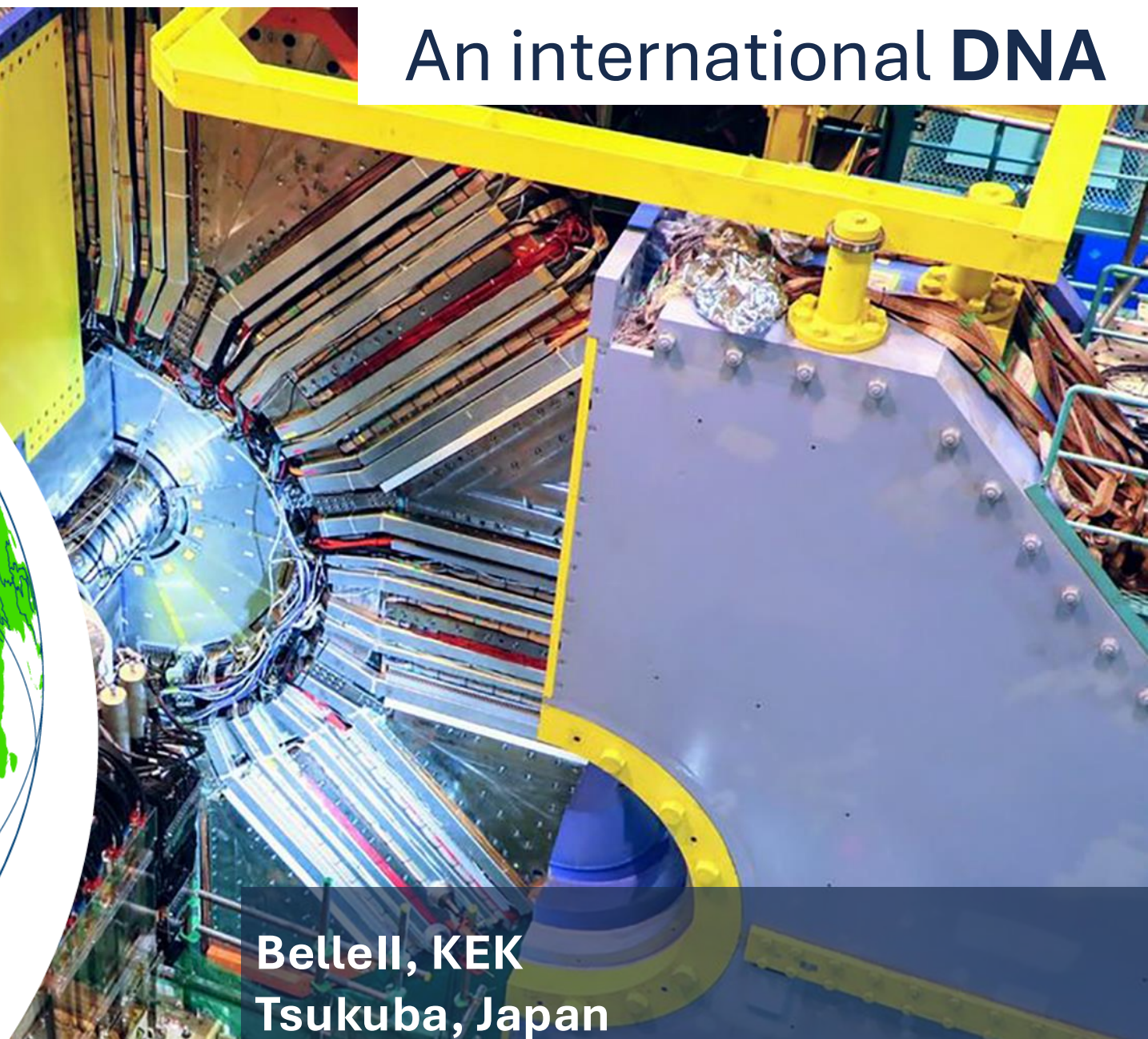

**BelleII, KEK
Tsukuba, Japan**

An international DNA



**European Spallation Source (ESS)
Lund, Sweden**

An international DNA



**Jiangmen Underground Neutrino
Observatory (JUNO)
Kaiping, China**

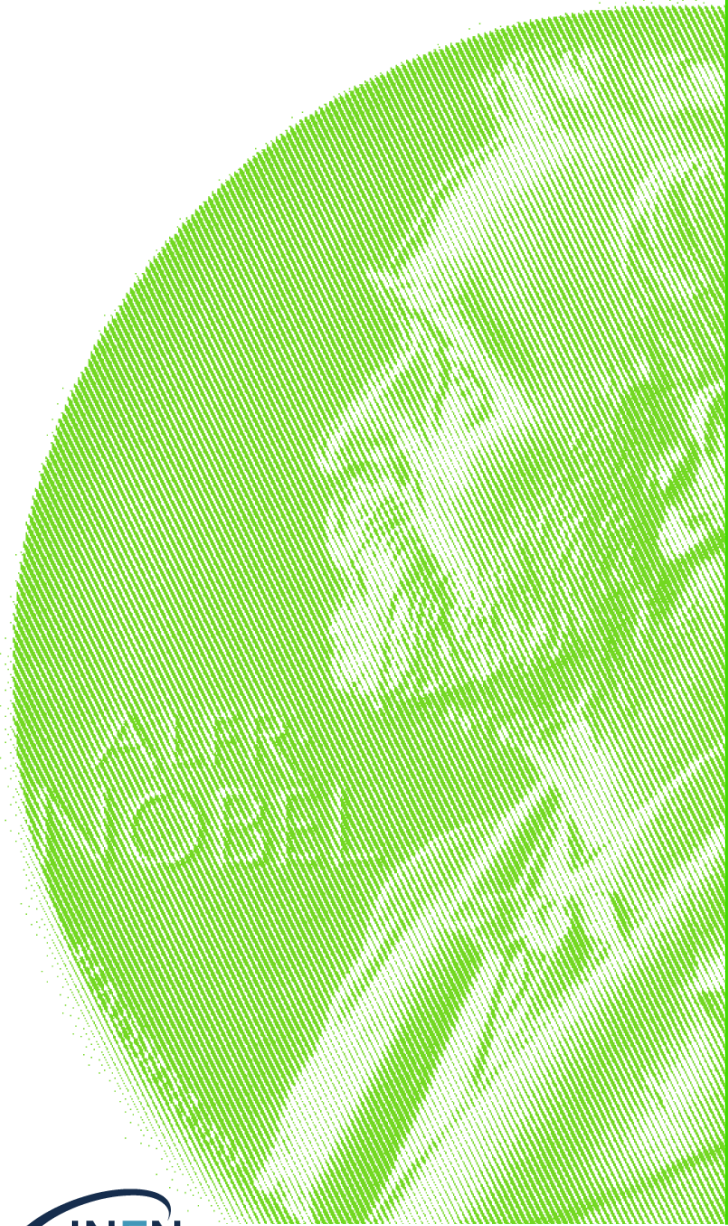

BOSONE DI HIGGS 2012



ONDE GRAVITAZIONALI 2017

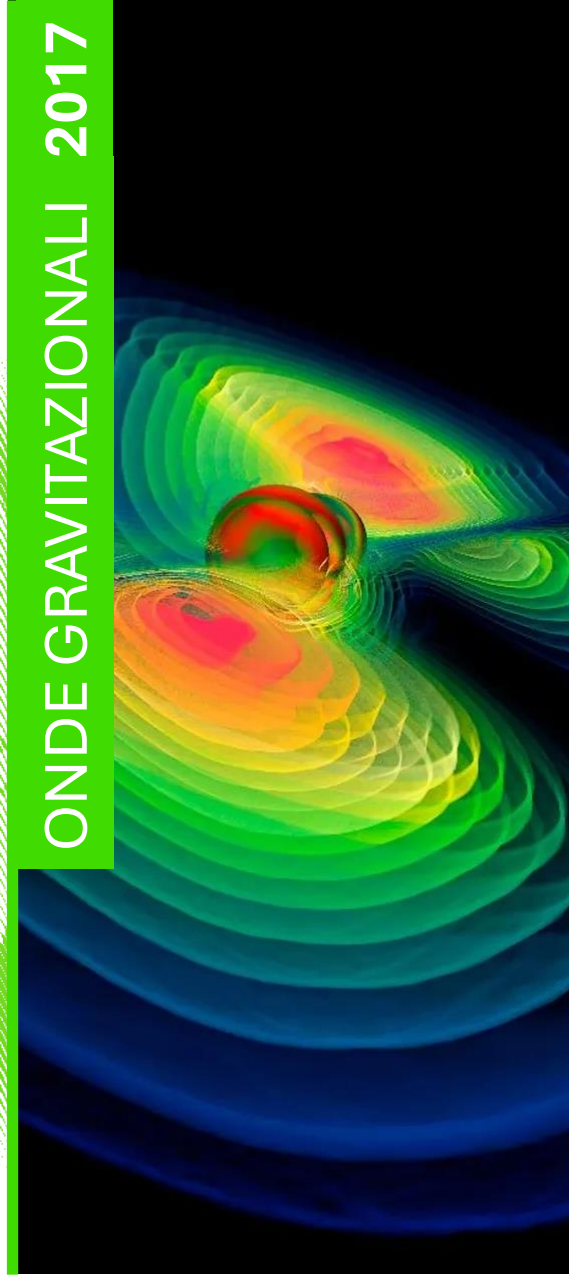

GIORGIO PARISI 2021



INFN is ...

a community of over
7.000 people

~ **25%** of which post doctoral positions,
research and doctoral grants



Number of staff Permanent / Fixed-term

TI



PERMANENT 2118

males 1505

females 613

TD



FIXED-TERM 280

males 194

females 86

Up to 31/12/2025

Permanent staff

Researchers **638**

Technologists **471**

Technicians **600**

Administratives **407**

Administrative directors **2**

Total permanent staff

2118

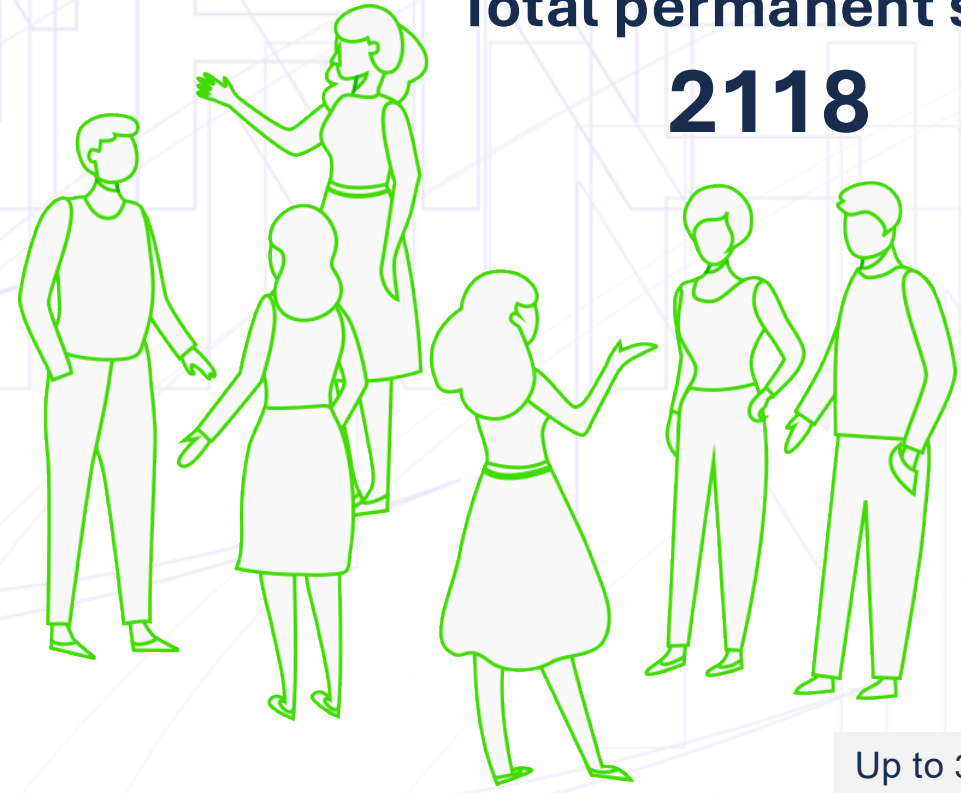

Up to 31/12/2025

Associated people **5409**

| | |
|------------------------|-------------|
| Post doctoral | 436 |
| Research grants | 61 |
| Doctoral grants | 1547 |
| Senior post doctoral | 837 |
| Other associations | 2338 |
| Technical associations | 190 |



Age distribution

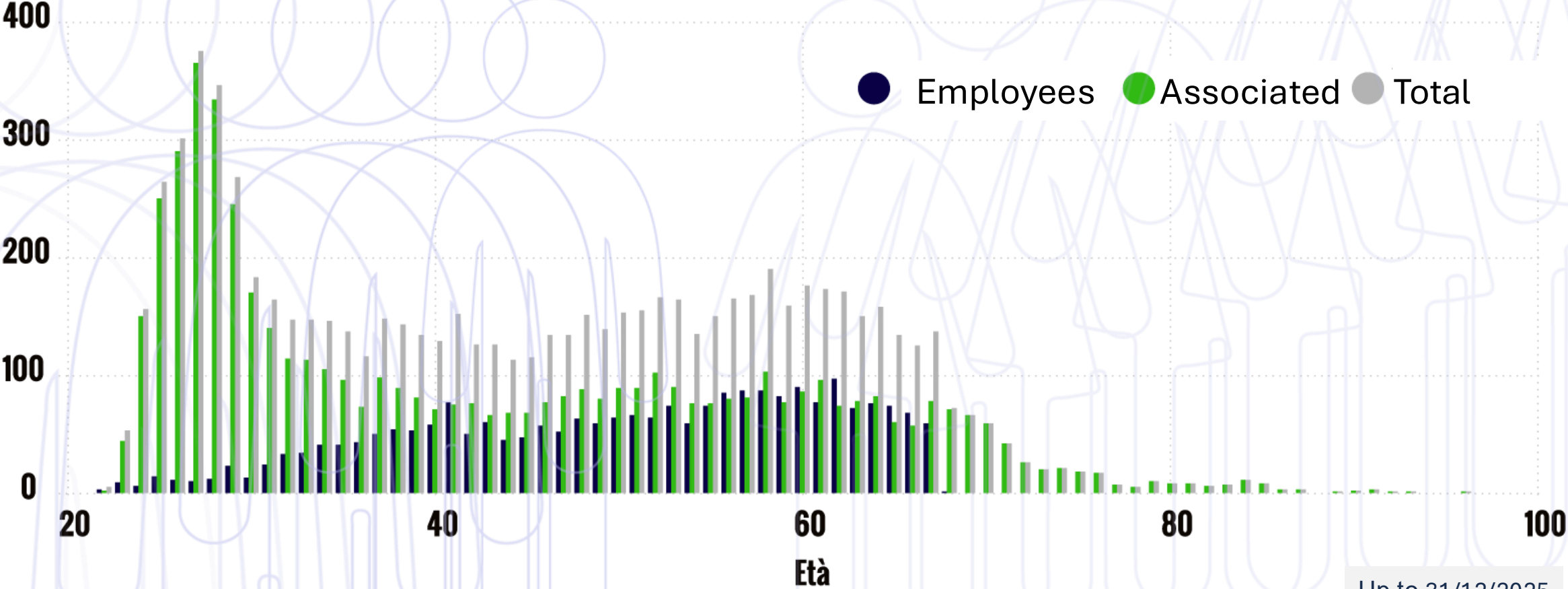

Up to 31/12/2025

Staff

... in training



Post-doc

INFN
375

Associated
436

Research grants

95

61

Doctoral grants

1547

Up to 31/12/2025

Budget 2025

473 mln euro

Financial resources
excluding
Restricted Funds

322,4
mln euro

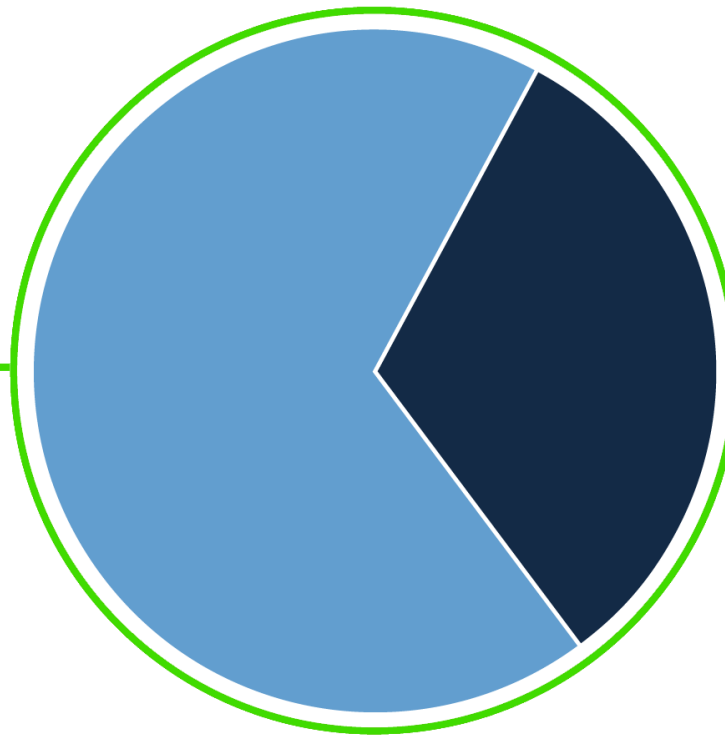

Restricted Funds
for specific projects

150,6
mln euro

Previsional budget 2026

Research expenditure profile,
staff and operation

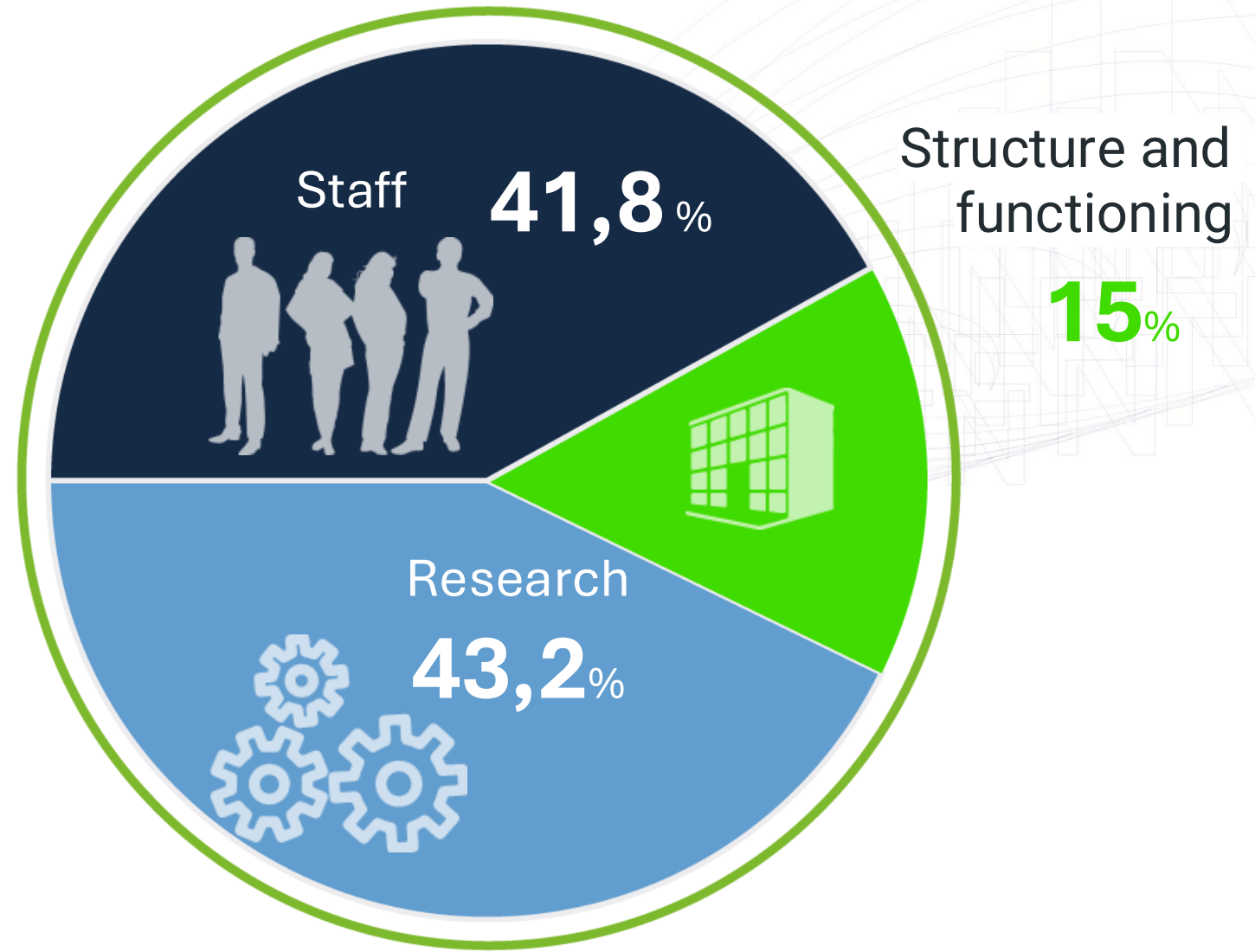

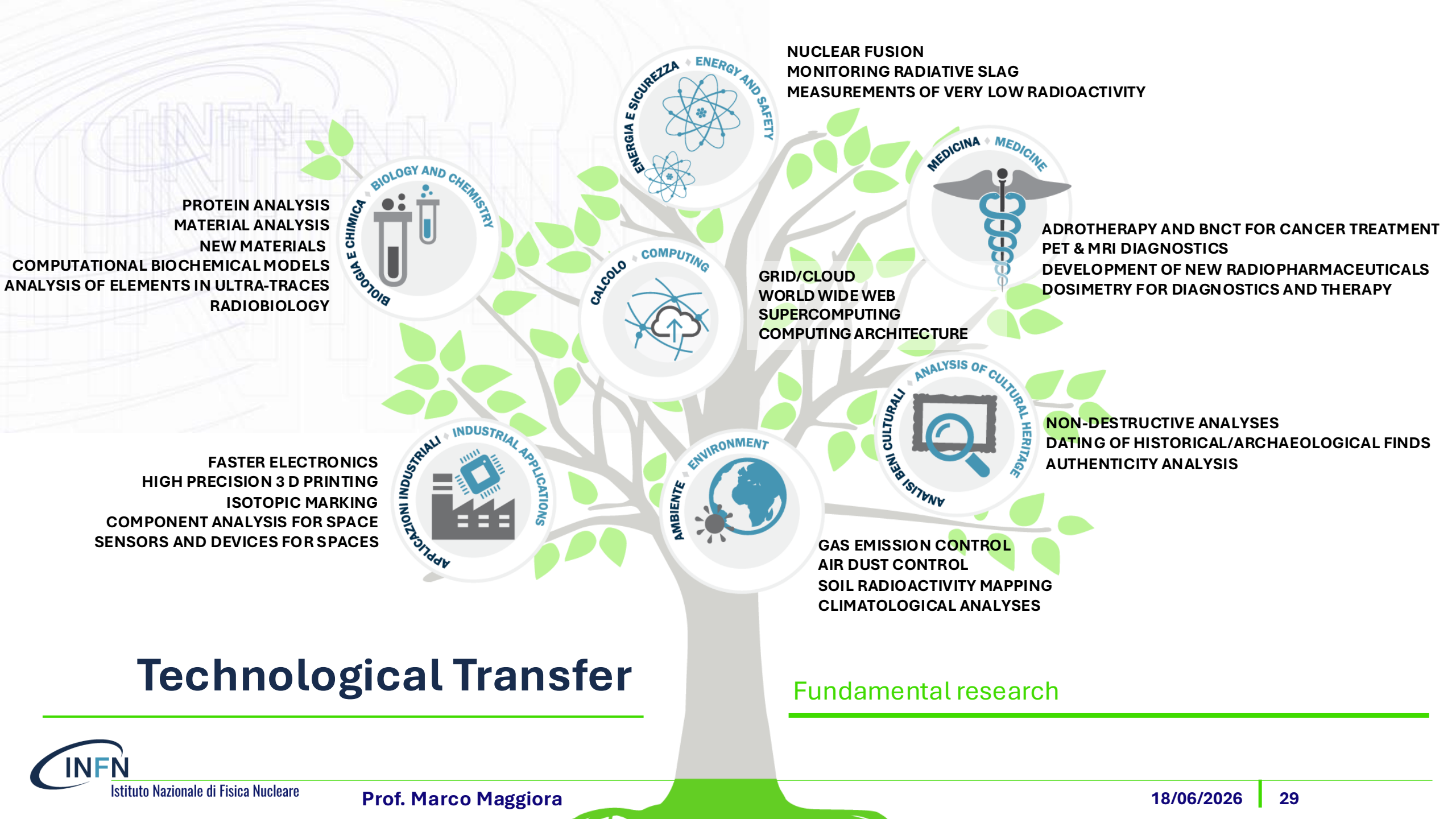

Technological Transfer

Fundamental research

MEDICINA MEDICINE



Technological Transfer

Prof. Marco Maggiora

CNAO Pavia

Communication and Public Engagement

Communication e Public Engagement

In **2023**, the INFN engaged a live audience of approximately **105,000** people in its activities, including **40,400 students**

Press Activities Communication Office

... in 2025



Press releases

63

News

83

Press and web quotes

5553

Radio and TV quotes

184





IHEP-INFN Joint Laboratory (I2JL)

A bridge among China and Italy

Basic Information

| | |
|------------------------------|--|
| Name | IHEP-INFN Joint Laboratory (I2JL) |
| Location | Beijing |
| Organisations | Institute of High Energy Physics (IHEP), Chinese Academy of Science (CAS) Italian Institute of Nuclear Physics (INFN) |
| Field of research | High Energy Physics and Nuclear Physics, Detector and Accelerator technologies, Astroparticle Physics and cosmic ray measurements, IT, High Performance Computing, GRID- and cloud-based technologies, Physics in the space, medical applications. |
| Collaboration details | Established on 2012. Heir of the Agreement among CAS and INFN signed in 2008 for a Joint Laboratory coordinated by IHEP. |

Our Experience

Practices we have been particularly successful with:

- Organizing a common Chinese-Italian effort in addressing the requirements of cutting edge technological solutions in BESIII, DAMPE, JUNO and their computing and medical applications
- Development and implementation of state of the art (and beyond!) detectors: HEP inner trackers, cosmic ray and field detectors on satellites, dedicated Front End Electronics
- Coordinating funding from different Agencies in China and in Italy, gaining also access to EU H2020 funding (BESIIIICGEM and FEST RISE Projects)
- Building combined management structures
- Develop coordinated educational and training opportunities in both Countries

Our Experience: BESIII

The CGEM-IT: The new inner tracker of BESIII experiment

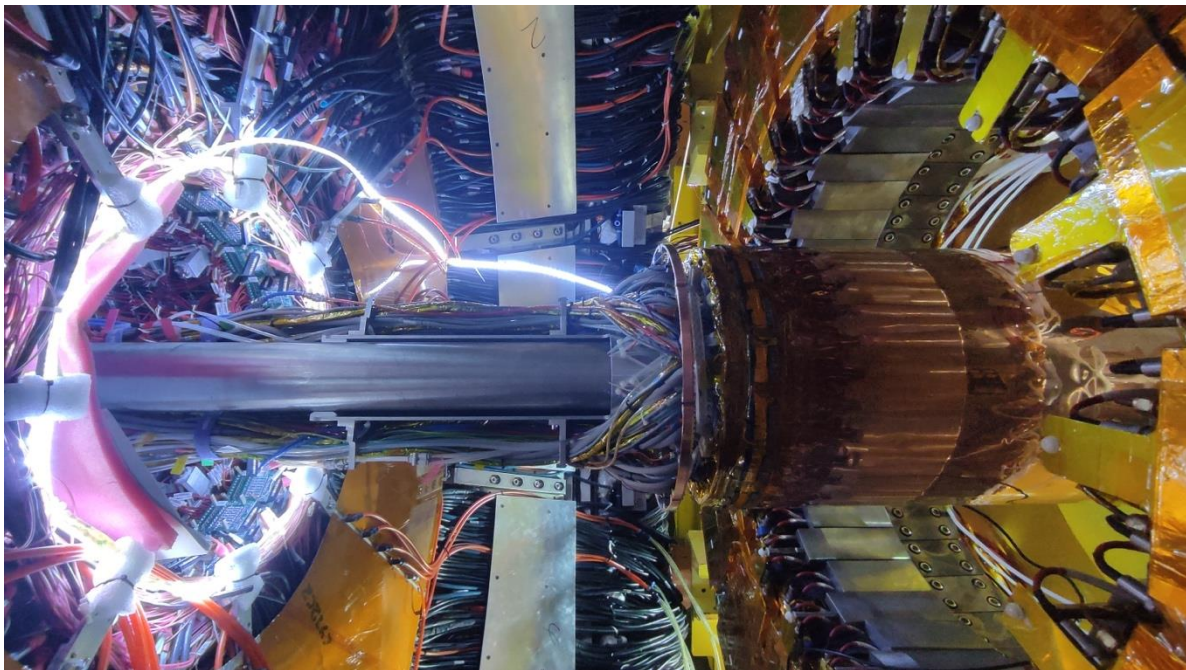

10-year project
Training ground for a generation of young researchers

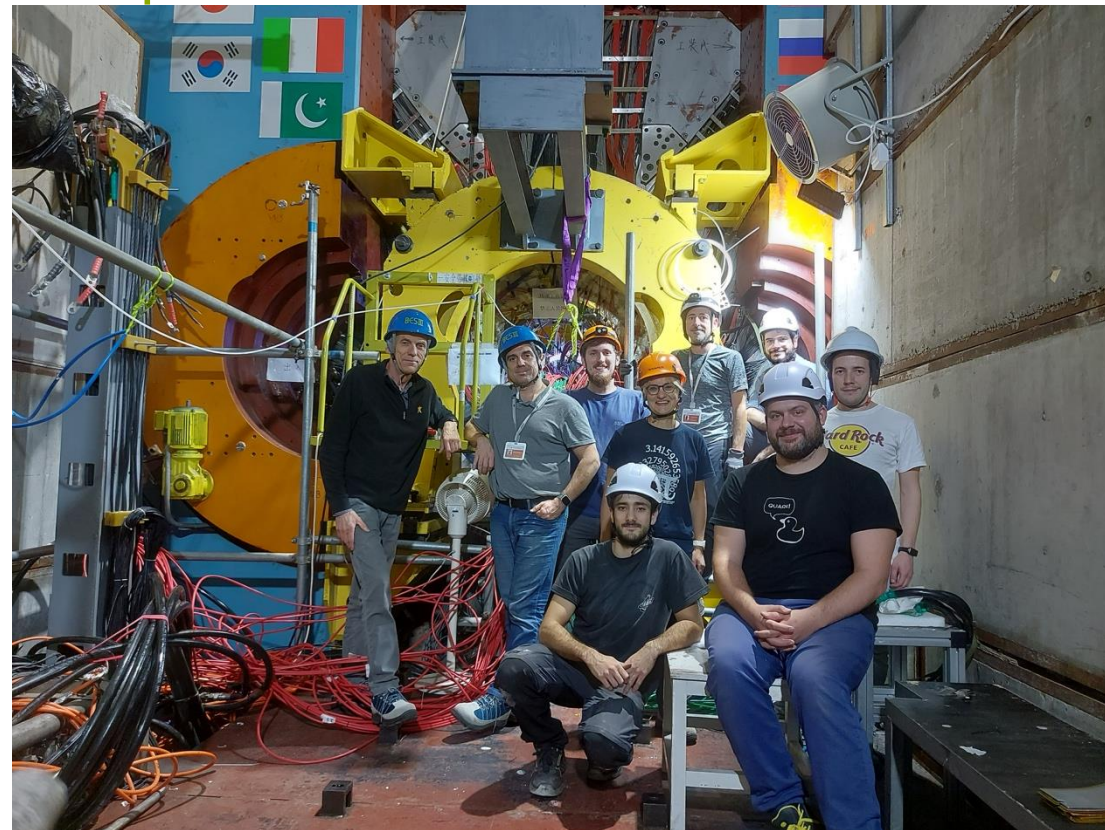

INFN-led international collaboration funded by MAECI-MOST, European commission (BESIIICGEM, FEST) and base for several future projects (MAECI-NSFC, CAS)

Installed in 2024, during the summer shutdown. **First ever non-Chinese detector on floor in a Chinese experiment**



Our Experience: BESIII

The CGEM-IT: The new inner tracker of BESIII experiment

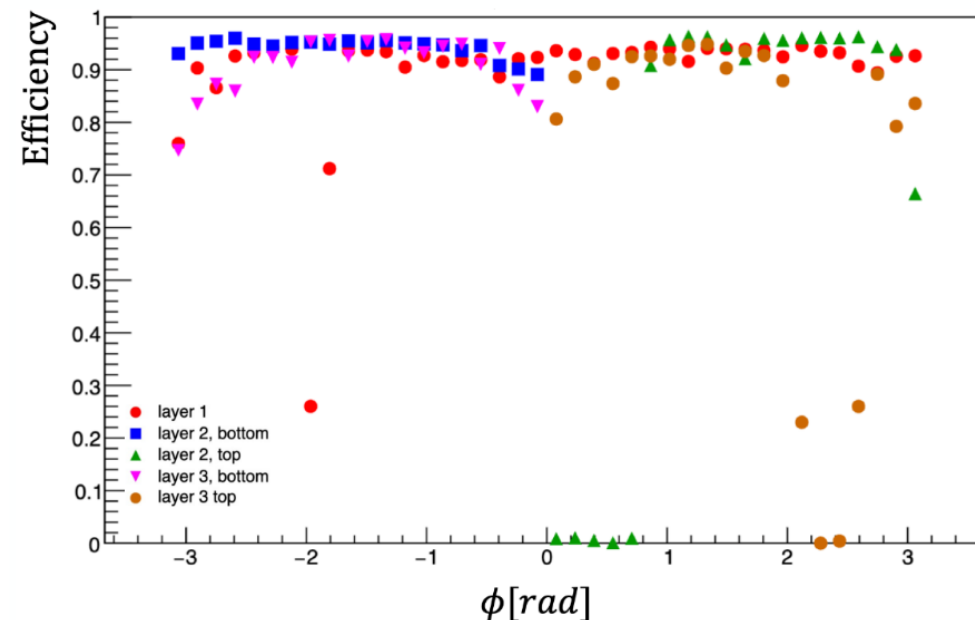
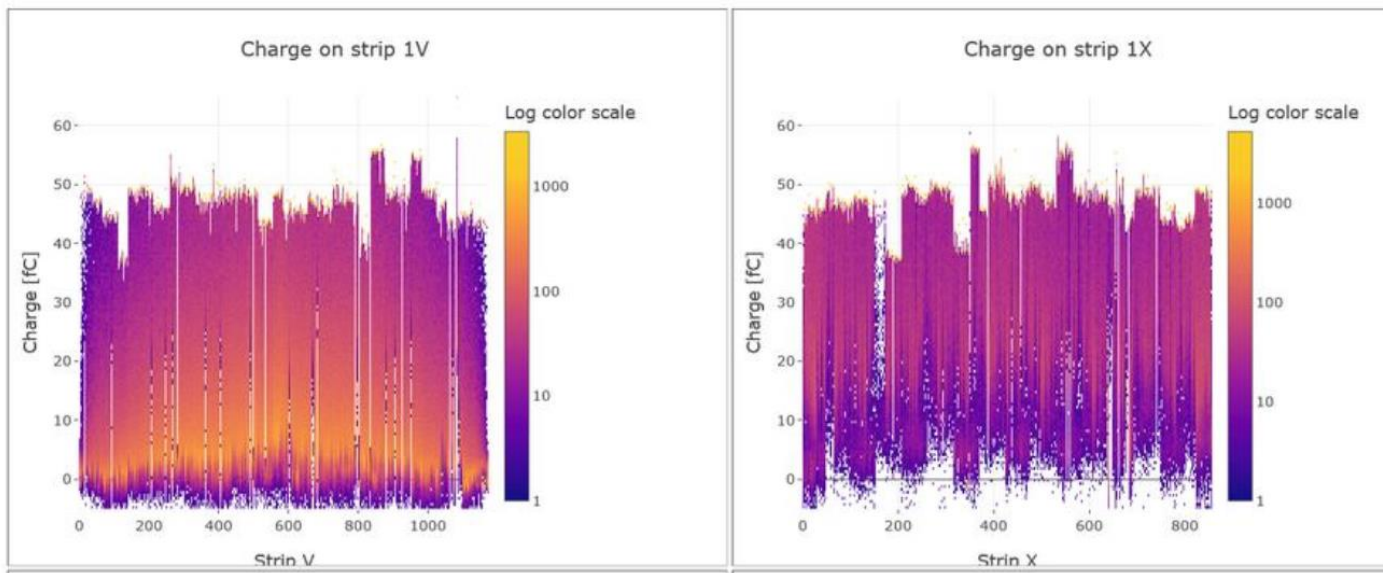

Start of the operations in May 2025, $\sim 1/\text{fb}$ data for **commissioning** at $\psi(3686)$ energies completed in February 2026, now taking **physics data** at 4.7 GeV with upgraded BEPCII-U

INFN supports the **detector operations** with **expert on-call** at IHEP, **DAQ developments**, **data analysis**, expertise for **simulation** and **reconstruction** in collaboration with IHEP experts

Our Experience: BESIII

Data analysis: hyperon structure, relative phase, charmonium decays

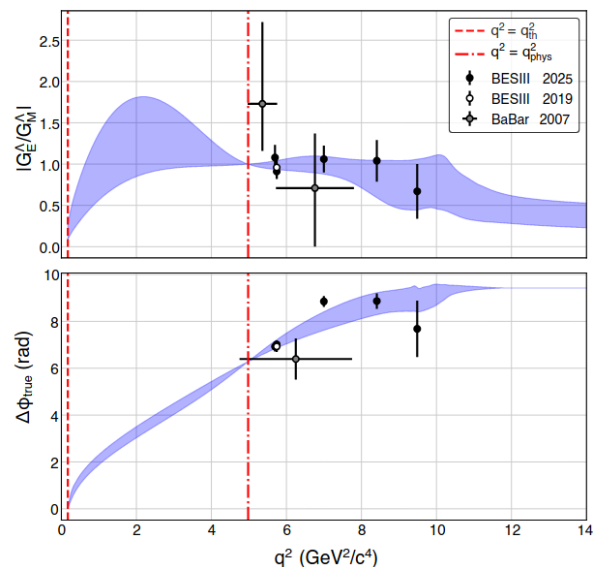

Measurement of Λ hyperon mean square charge radius

Leading studies in measurements of the relative phase between strong and electromagnetic decay of charmonia

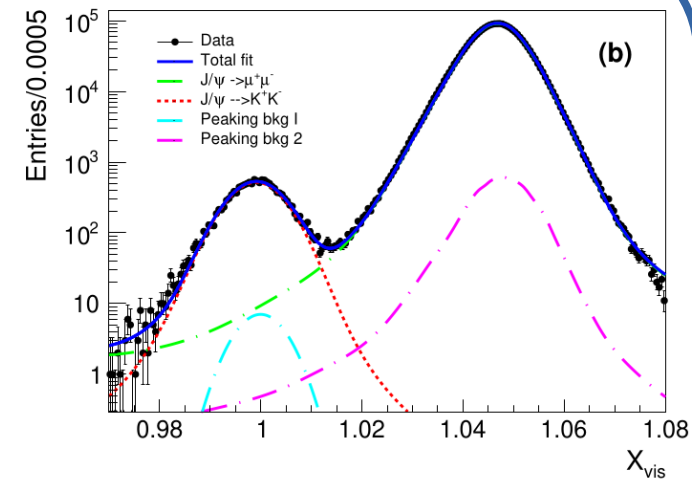
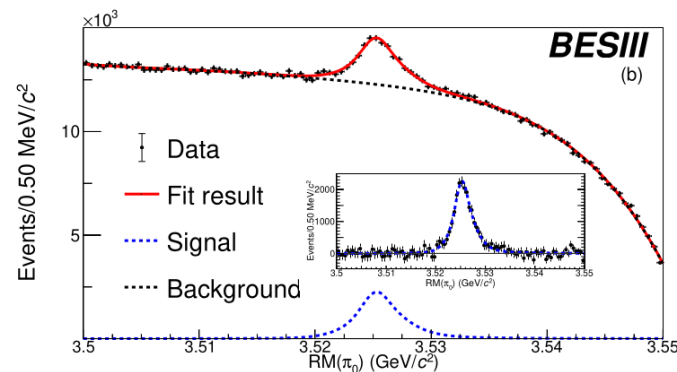
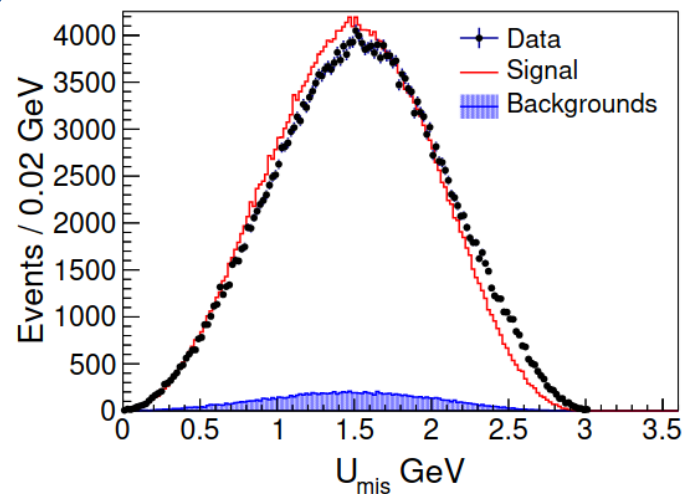

World's best measurements of branching ratio of $\psi(3686) \rightarrow \tau\tau$, $J/\psi \rightarrow KK$, and $h_c(1P)$ mass and width

Our Experience: BESIII

Hadron and τ -charm physics at the $e^+ - e^-$ BEPCII collider



- Impressive discoveries record
- Impressive publication record
- **CGEM-IT, the new Inner Tracker**

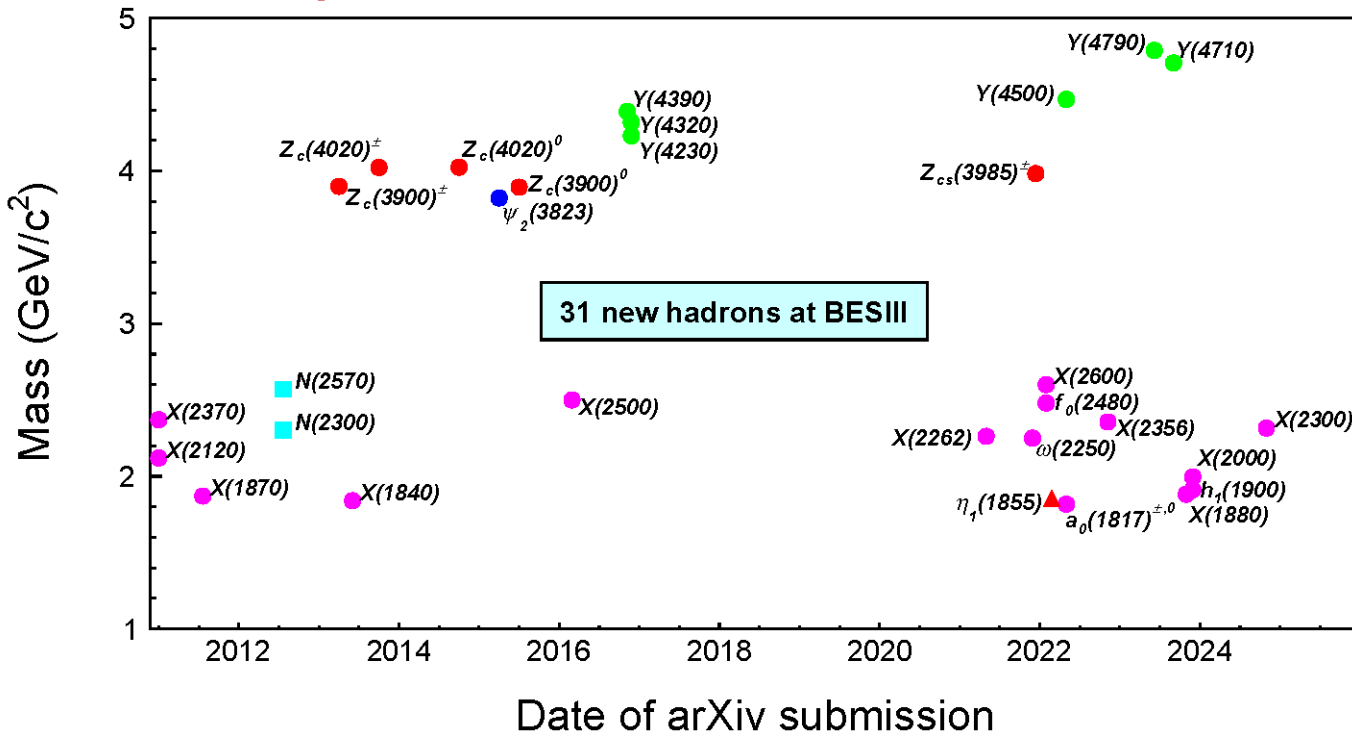

Publications as of Mar. 20th, 2026

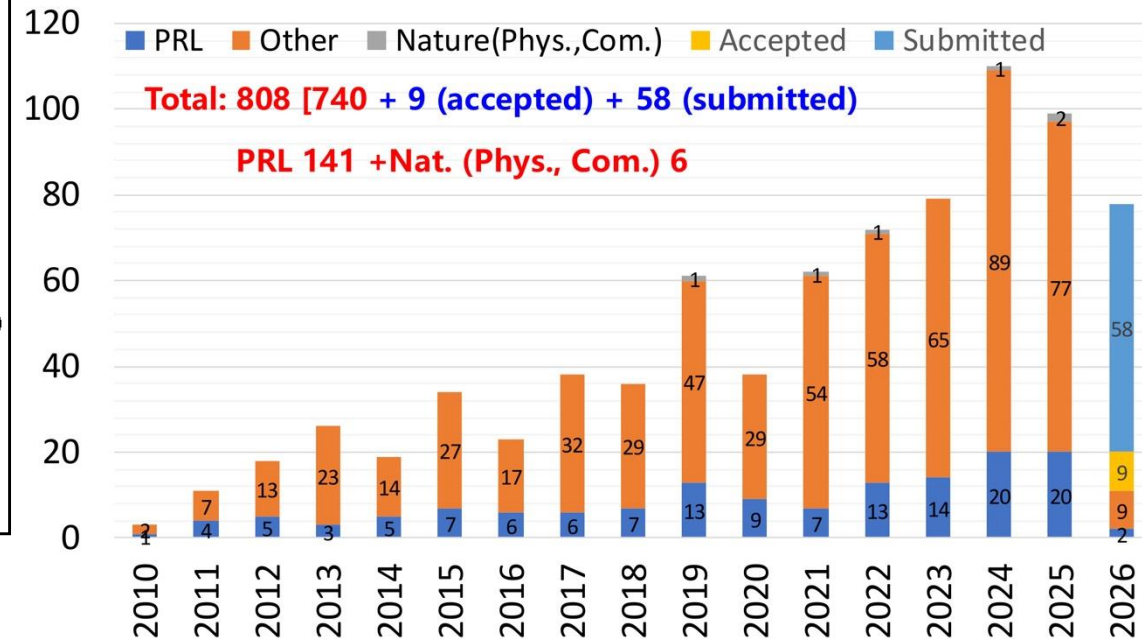

Our Experience: DAMPE

Cosmic Rays – Gamma Ray Astronomy – Indirect Dark Matter searches

- Data taking since Dec. 2015
- Unprecedented studies of galactic cosmic rays up to the PeV scale

Plastic Scintillator Detector (PSD) (~0.2e)

Silicon-Tungsten Tracker (STK) (~50μm)

BGO Calorimeter (CALO) (31 X₀)

Neutron Detector (NUD)

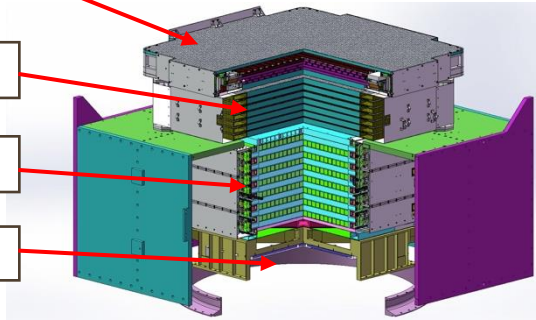

Bridge with ground based experiments

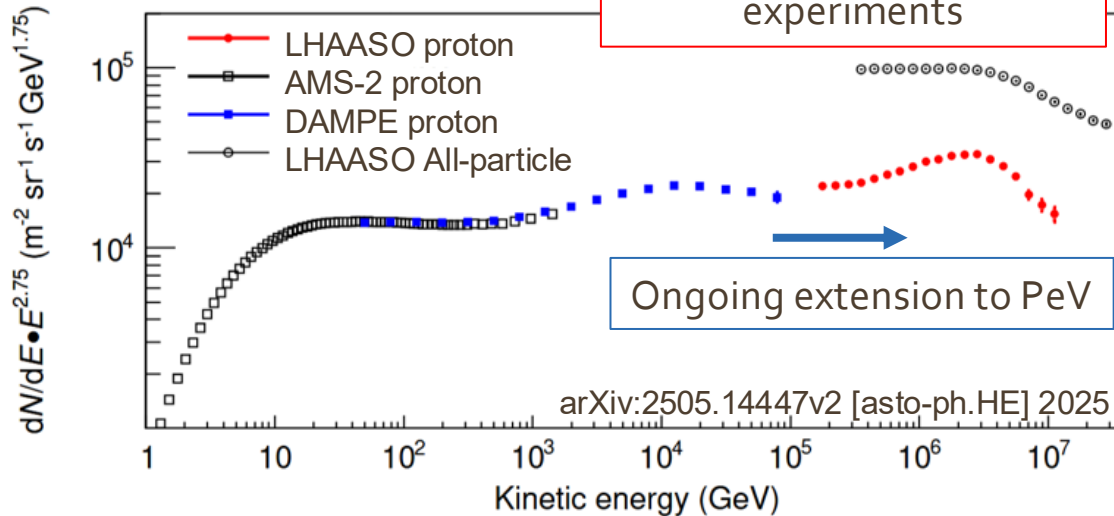

arXiv:2505.14447v2 [astro-ph.HE] 2025

Prof. Marco Maggiora

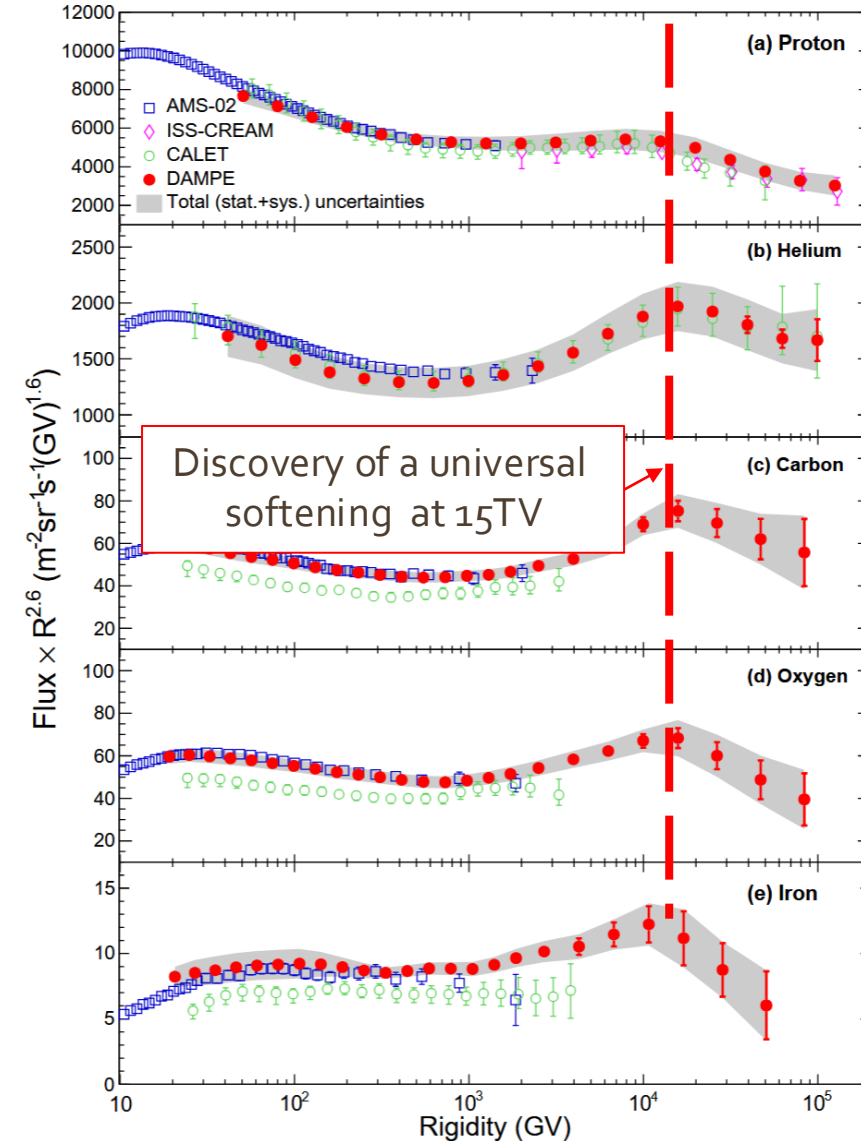

Istituto Nazionale di Fisica Nucleare

Our Experience: JUNO

Neutrino and astroparticle physics @ Kaiping, Jiangmen, Guangdong



$$\sin^2 \theta_{12} = 0.3092 \pm 0.0087 \text{ (2.81\%)}$$

$$\Delta m^2_{21} = (7.50 \pm 0.12) \times 10^{-5} \text{ eV}^2 \text{ (1.55\%)}$$

- Italy is the second country for number of collaborators and funding contribution.
- Determination of the so called “solar oscillation parameters” with only first 60 days of data taking (start: end of August 2025). **Factor of 1.6 improvement w.r.t. pre-JUNO knowledge from experiments in the field carried out over the past 5 decades.** Other parameters and the neutrino mass hierarchy (MH) will be determined with future data taking.

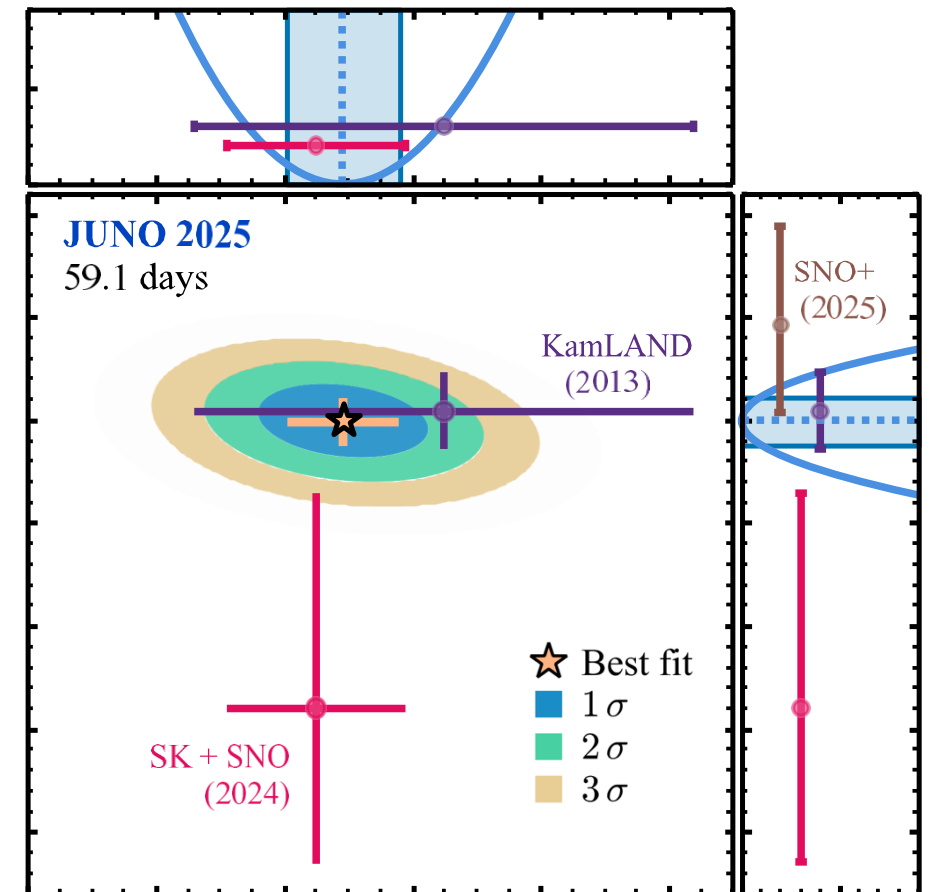

Our Experience: JUNO INFN contributions



Scintillator purification

- Distillation and stripping

Stripping

Distillation (for heavy impurities) and **stripping** (for gaseous impurities) plants for liquid scintillator purification - designed on the basis of the **Borexino** experience – built in Italy – installed, commissioned on the experimental site by our group and then operated continuously during the **seven months** of detector filling **February-August 2025**



Stripping

Our Experience: JUNO

INFN contributions



Electronics

- GCU
- Tracker read-out
- Trigger



Global control units GCU for read-out electronics of the Large PMT's - 7000 boards produced, tested and assembled in the Under Water Boxes (submarine electronics) – essentially all of them properly working underwater for almost two years



1000 read-out boards for the TOP Tracker (retrieved from OPERA) electronics produced and tested in Italy and delivered to the JUNO site – In addition, 80 concentrator boards to collect their signals – Full system in operation during data taking

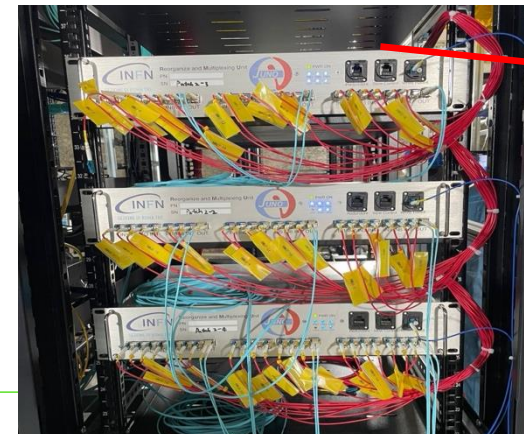

Trigger units for the global trigger generation – produced, tested delivered, assembled and in use in the JUNO electronic roomx

Our Experience: JUNO

INFN contributions



Moreover:

- JUNO_TAO

For the **JUNO_TAO** satellite detector

- Selection and contribution to purchase and testing of the read-out **SiPMs 4000 units in total**
- Design of the **Front-end boards** and **ADC boards** of the related read-out electronics
- **Construction done in Italy** SiPM and electronics installed in TAO and employed in the current data taking



Our Experience: JUNO

INFN contributions



Moreover:

- Radiopurity
- Analysis & computing

Other JUNO involvements

- **Radioactivity control and screening** of materials - Nuclear Activation Analysis of the liquid scintillator
- **Computing** (also **CNAF**) and realization of the **DCI** Distributed Computing Interface for data transfer among data centers
- **Geological modeling** for geoneutrino signal
- **Laboratory measurements** for characterization of liquid scintillator properties
- **Study of reactor antineutrino spectra**
- **Vast effort for MC and analysis, thoroughly participating to the ongoing data interpretation after the start of data taking**

INFN Divisions in the Collaboration :

- Catania
- Ferrara,
- Frascati
- Milano,
- Milano Bicocca
- Padova
- Perugia
- Roma Tre

About 70 people for 40 FTE

Our Experience: CEPC / FCC ARCADIA FD-MAPS CMOS Sensors



- **INFN CSN5 Open Call on development and production of deep-submicron monolithic CMOS sensors on a 110nm CIS technology**
 - Collaborative research between INFN and LFoundry (chip manufacturing fab in Italy)
 - R&D in semiconductor sensor technology, IP-core design and ASICs for application in high-energy, astroparticle and medical physics
 - Development of very low-power frontier silicon tracker detectors (baseline technology for IDEA) for **future leptonic colliders (FCC and CEPC)**
 - Innovative CMOS sensors with gain layer (CMOS LGAD) for frontier photon and charged particle detectors with **time-of-flight capabilities**
 - Enabling technology to develop fully-depleted CMOS sensors with excellent charge collection efficiency for **medical applications**
 - Follow-up funding from ASI “SpaceltUp!”, ERC AdG “Si3” and EIC Pathfinder Open “1MICRON”, projects ongoing

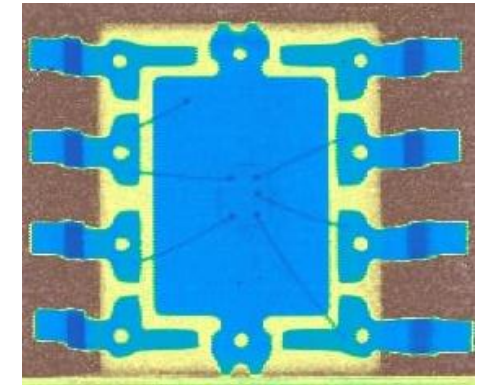
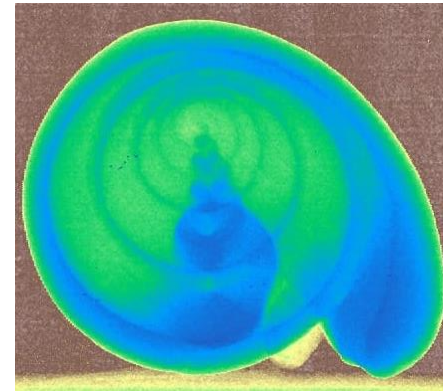
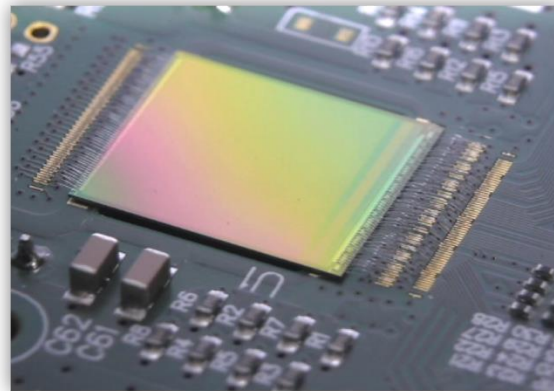
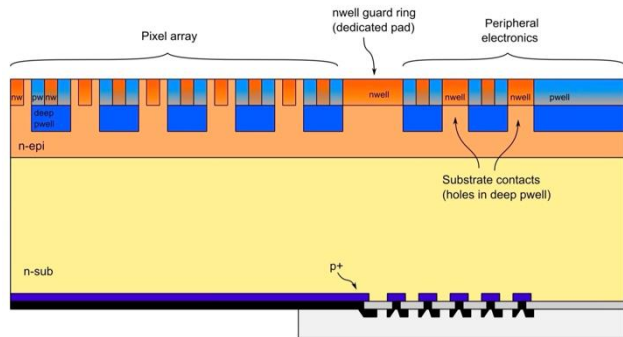

Our Experience: CEPC / FCC ARCADIA FD-MAPS CMOS Sensors



João Guimarães da Costa
(on behalf of the CEPC Project)
April 7, 2026

| Design Parameters | |
|--------------------------|--|
| Parameter | Design |
| Spatial Resolution | $\sim 5 \mu\text{m}$ |
| Detector material budget | $\sim 0.8\% X_0$ |
| First layer radius | 11.1 mm |
| Power Consumption | $< 40 \text{ mW/cm}^2$ (air cooling requirement) |
| Time stamp precision | 100 ns |
| Fluence | $\sim 2 \times 10^{14} \text{ Neq/cm}^2$ |
| Operation temperature | $\sim 5^\circ\text{C}$ to 30°C |
| Readout electronics | Fast, low-noise, low-power |
| Mechanical Support | Ultralight structures |
| Angular Coverage | $ \cos \theta < 0.99$ |

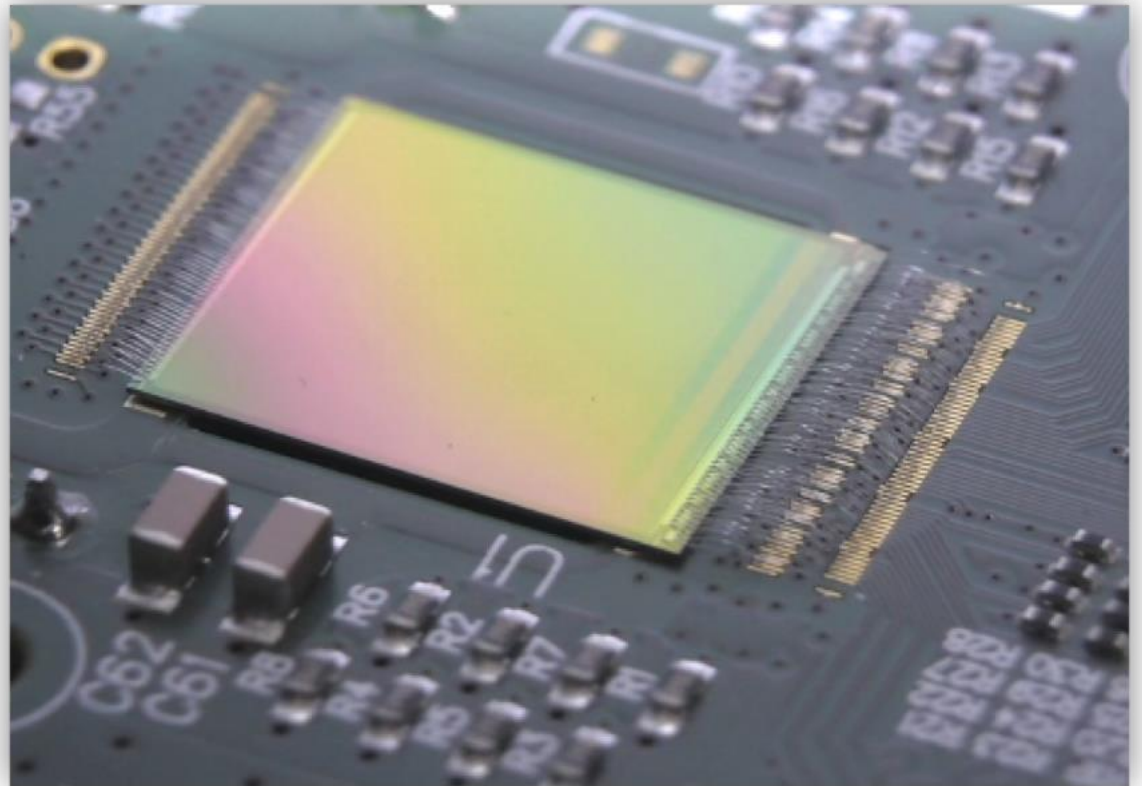

Our Experience: CEPC / FCC

The IDEA Tracking detectors for FCC/CEPC

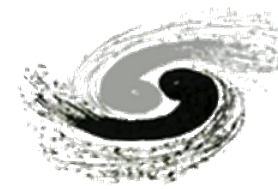

- **The Silicon Tracker of IDEA features two main subsystems, whose active elements are based on 50 μm thick Monolithic Active Pixel Sensors (MAPS)**
 - an inner vertex detector, located closer to the beam pipe, between 13.7 and 34 mm, covering an angular acceptance of about $|\cos(\theta)| < 0.99$;
 - an outer vertex detector, located at a larger radius between 11.2 and 31.5 cm, composed of a barrel section and forward disks;
 - The inner vertex detector is composed of three-barrel concentric layers. The elementary unit is a module of dimensions 32(z) × 8.4(r-φ) mm². Each module has two chips abutted in z inspired from the ARCADIA INFN R&D; The active area is made of 640 (z) × 256 (r-φ) pixels of 25 × 25 μm² size.

August 20th, 2023

The FCC-ee interaction region, design and integration of the machine elements and detectors, machine induced backgrounds and key performance indicators.

Manuela Boscolo^{1*}, Fabrizio Palla^{2*}, Andrey Abramov³,
 Martin Aleksa³, Kevin D. J. Andre³, Filippo Bosi²,
 Giacomo Broggi³, Briec Francois³, Andrea Ciarna¹,
 Manuel Dionisio Da Rocha Rolo⁴, Francesco Fransesini¹,
 Andrea Gaddi³, Armin Ilg⁵, Stefano Lauciani¹, Dirk Mergelkhul³,
 Alexander Novokhatski⁷, Emmanuel Perez³,
 Leonard Reichenbach⁶, Andre Sailer³, Leonard Watrelot³

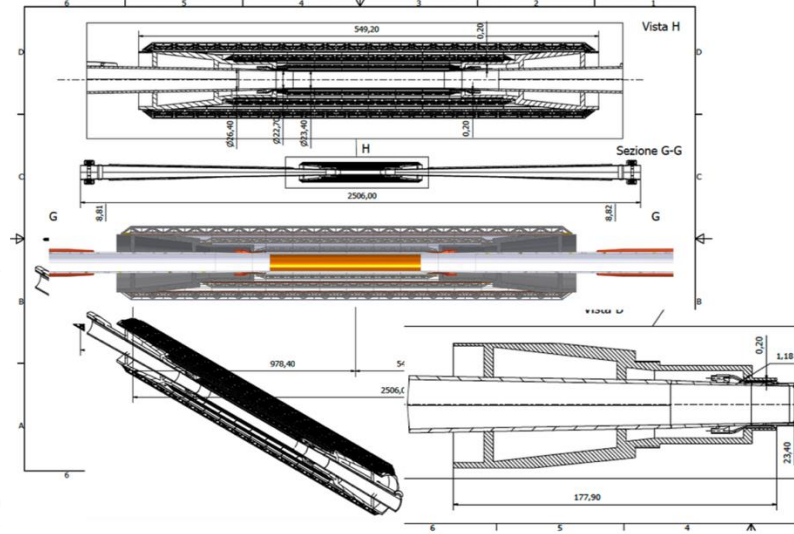
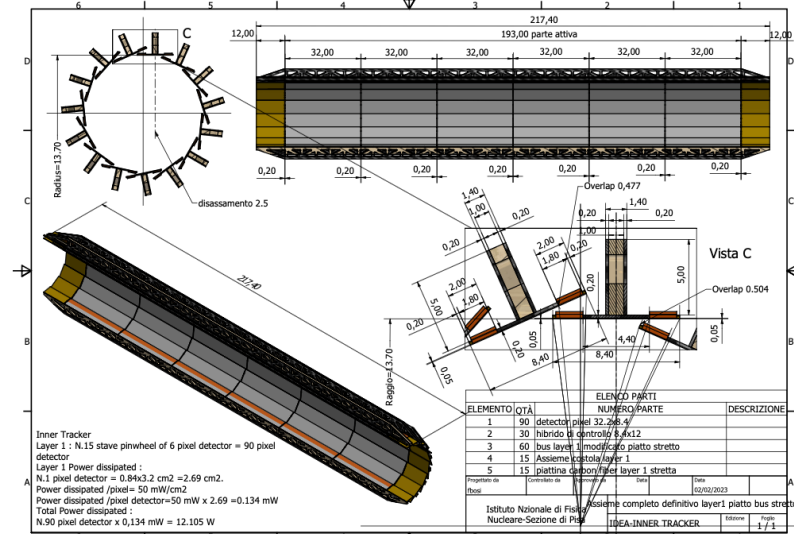

Our Experience: CEPC / FCC

ARCADIA MD₃ test-beam AT FNAL with 120 GeV protons



- mini-telescope with 3 ARCADIA-MD3 200 μm thick sensors
- Threshold, sensor HV and incidence angle parametrisation
- study of cluster size, collection efficiency, spatial resolution

Single-point resolution $\sim 4.7 \mu\text{m}$

average efficiency 99.23%

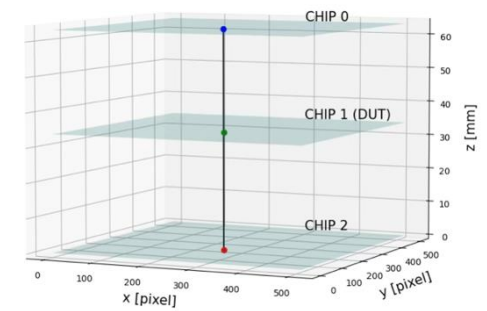
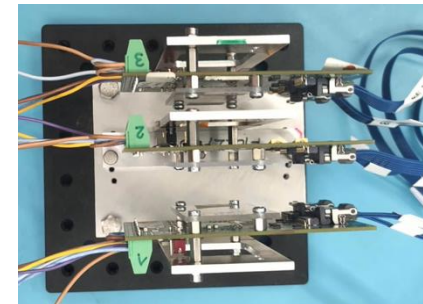
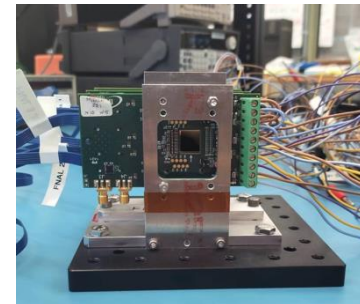
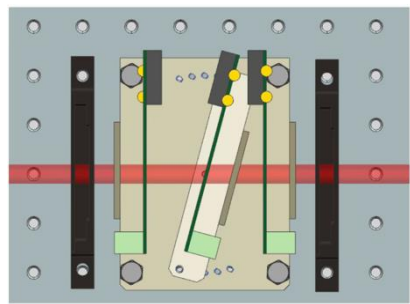
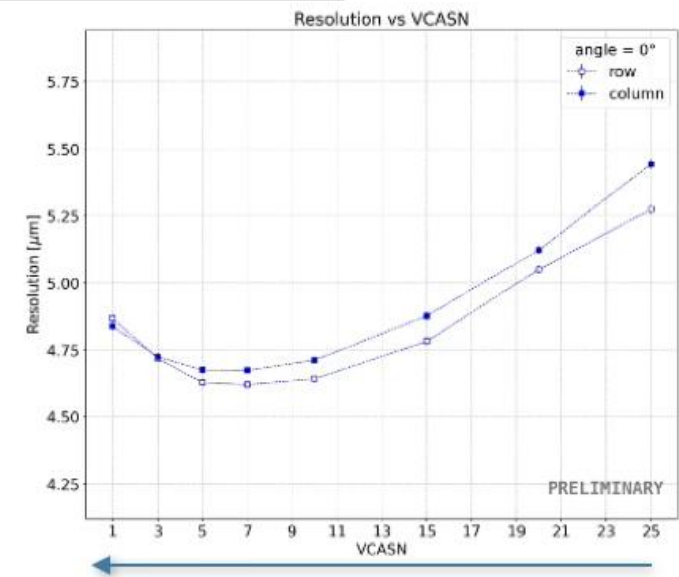
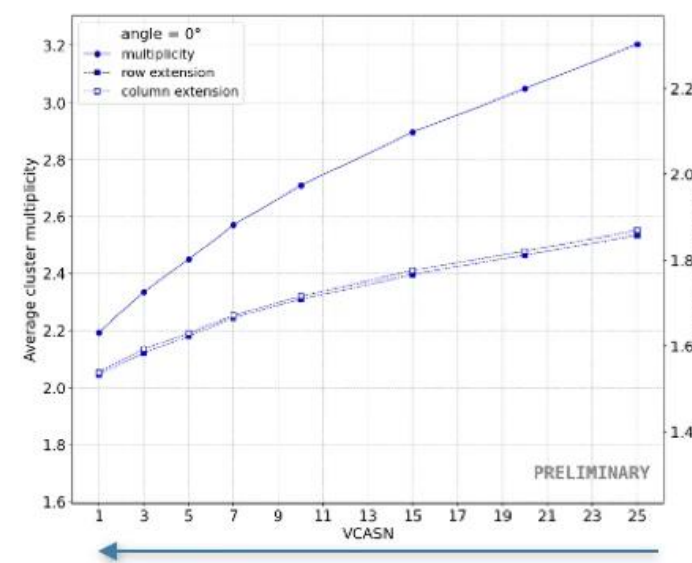
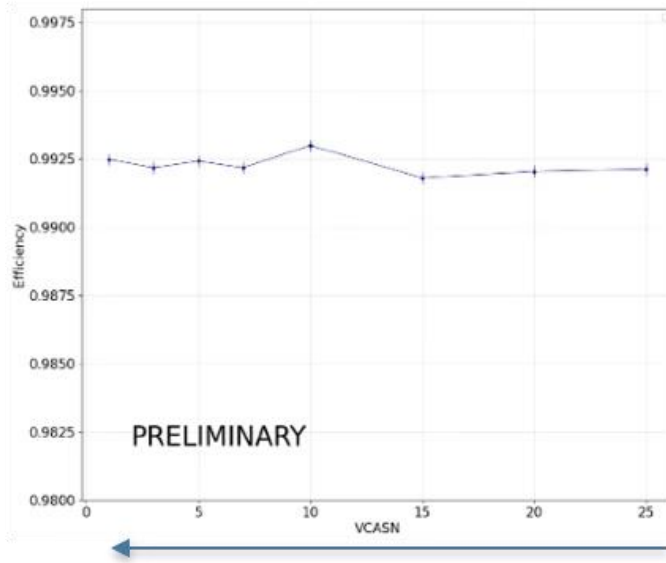

Our Experience: CEPC / FCC

ARCADIA CMOS-LGAD for TOF detectors



- p-type **gain implant** beneath the n+ collecting electrode to push the timing performance
- **time resolution** on thin substrates, estimated with MC studies based on experimentally-tuned simulations, **expected better than 20 ps r.m.s.**

development of fully-depleted MAPS

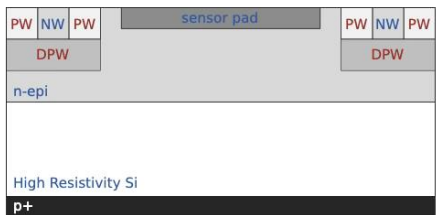

CMOS-LGAD

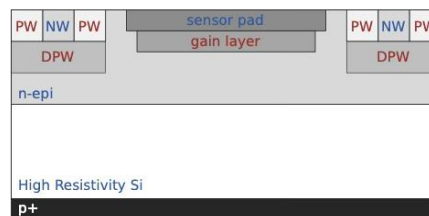

ALICE3 TOF detector:

- ▶ high-resolution **tracking**
- ▶ **particle ID** with low $p_T \Rightarrow \sigma_t \sim 20$ ps

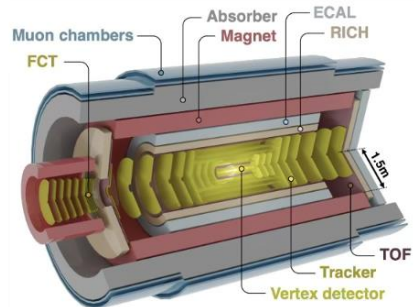

Add-on *p*-gain implant (gain target: 10 – 30)

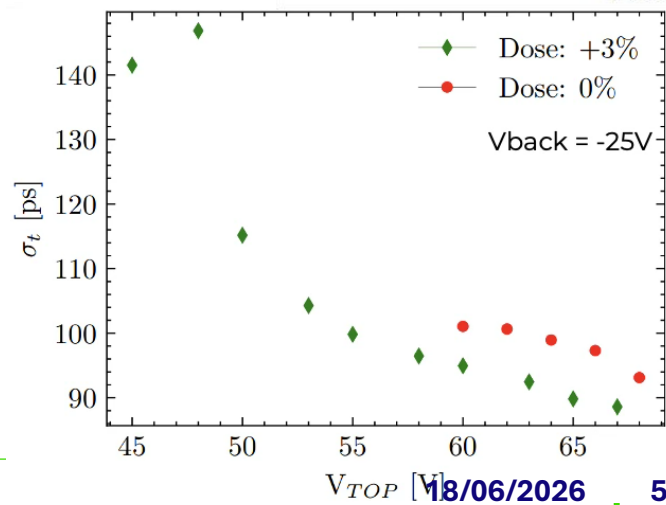
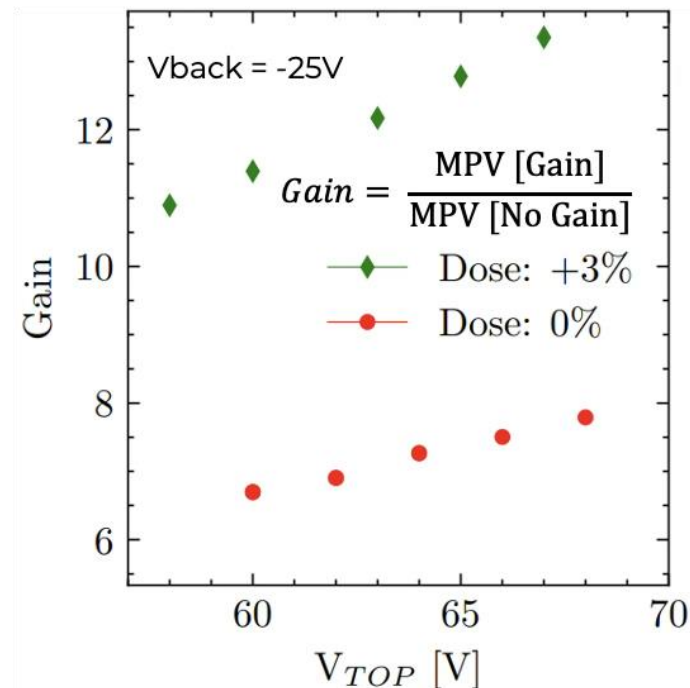
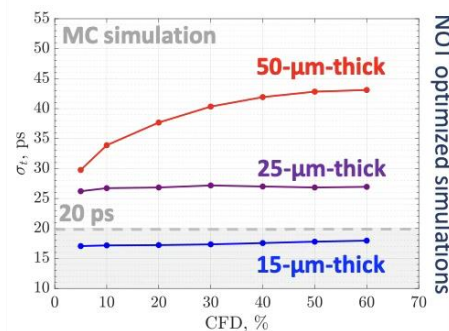

Standard 110 nm CMOS process at LFoundry



Our Experience: CEPC / FCC

CEPC: recent progress for full simulation

The IDEA DCH is:

- a unique-volume, high granularity, fully stereo, low-mass cylindrical
- **gas: He 90% - iC_4H_{10} 10%**
- **inner radius $R_{in} = 0.35m$, outer radius $R_{out} = 2m$**
- **length $L = 4m$**
- **drift length ~ 1 cm, drift time up to 400ns**
- $\sigma_{xy} < 100 \mu m$, $\sigma_z < 1$ mm
- **12÷14.5 mm wide square cells, 5 : 1 field to sense wires ratio**
- **112 co-axial layers (grouped in 14 superlayers of 8 layers), at alternating-sign stereo angles, in 24 azimuthal sectors**

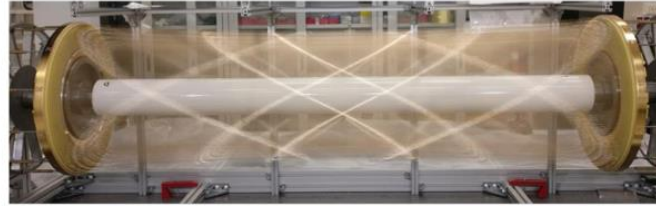

343968 wires in total:

sense wires: 20 μm diameter W(Au) => 56448 wires

field wires: 40 μm diameter Al(Ag) => 229056 wires

f. and g. wires: 50 μm diameter Al(Ag) => 58464 wires

N. De Filippis (INFN)
M. Dong (IHEP)
G. Zhao (IHEP)
L. Wu (IHEP)

CEPC drift chamber

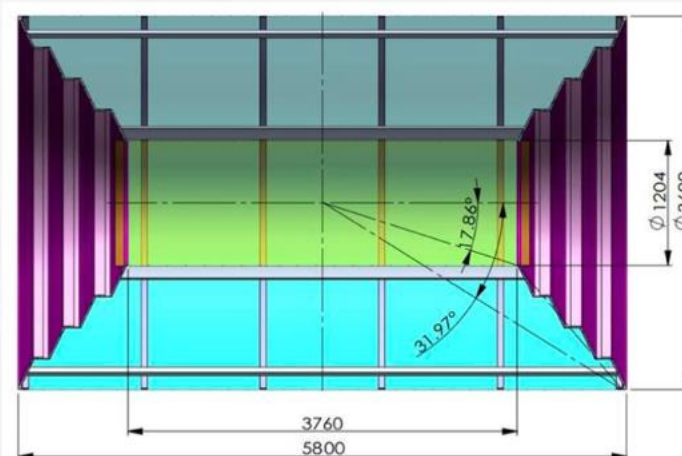

- R extension: 600-1800 mm
- Length: 5800 mm
- Cell size: ~ 18 mm \times 18 mm
- 64 wire layers and 26483 cells
- Ratio of field wires to sense wires: 3:1
- Gas mixture: He/ iC_4H_{10} = 90:10
- CF Frame structure: 8 longitudinal hollow beams + 8 annular hollow beams

Our Experience: CEPC / FCC

The Drift Chamber of IDEA and CEPC

N. De Filippis (INFN)
 M. Dong (IHEP)
 G. Zhao (IHEP)
 L. Wu (IHEP)



- Simulation package
 - Garfield++-based simulation
+ data-driven digitization
- Recent progress
 - extended to multi-cell configuration
 - ready for prototype experiment study

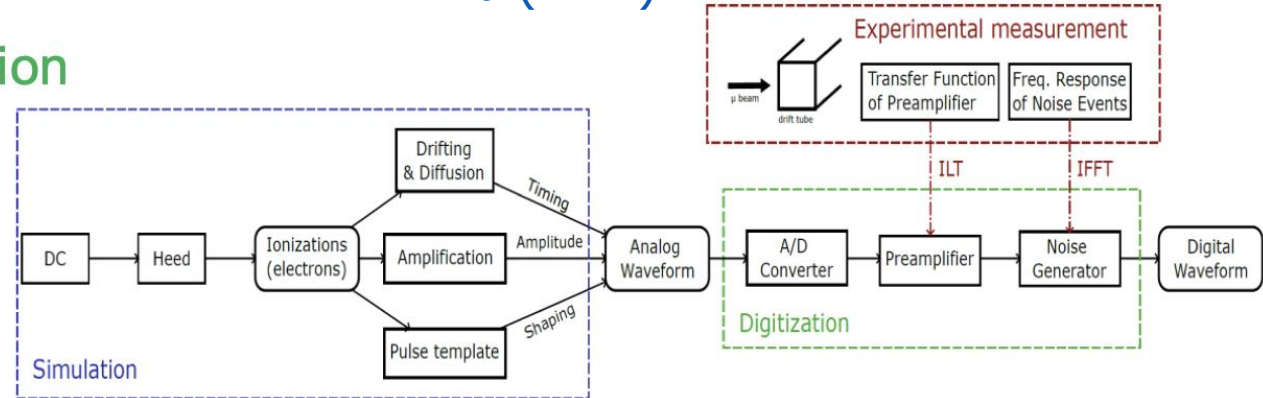

Multi-cell simulation

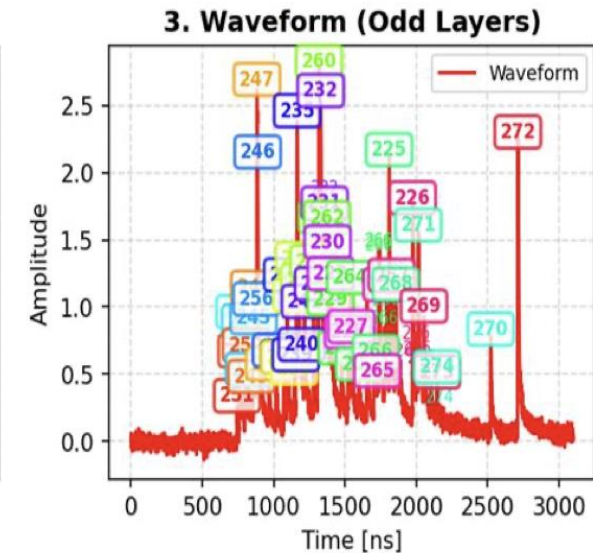
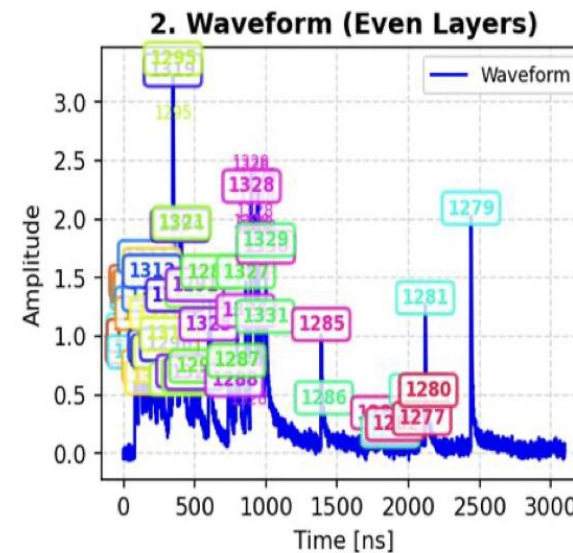
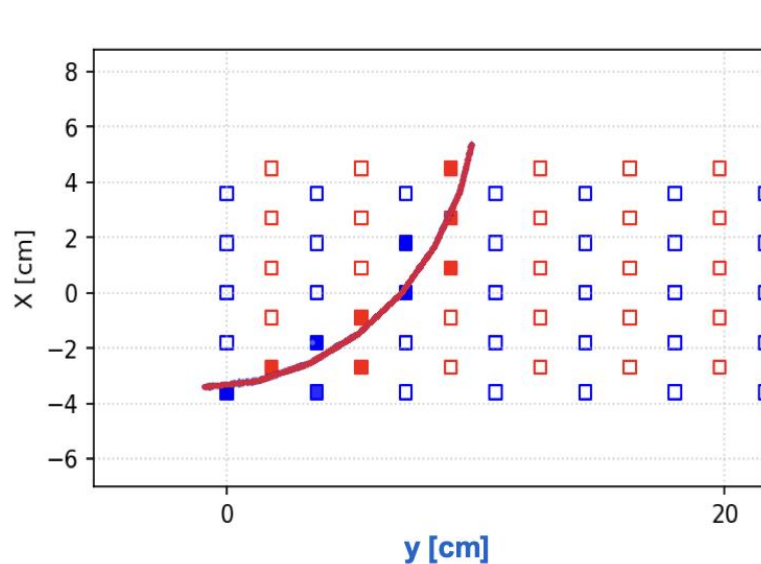

Our Experience: CEPC / FCC

CEPC/IDEA: Reconstruction with Deep Learning

- Simulation package
 - Garfield++-based simulation + data-driven digitization
- Recent progress
 - extended to multi-cell configuration
 - ready for prototype experiment study

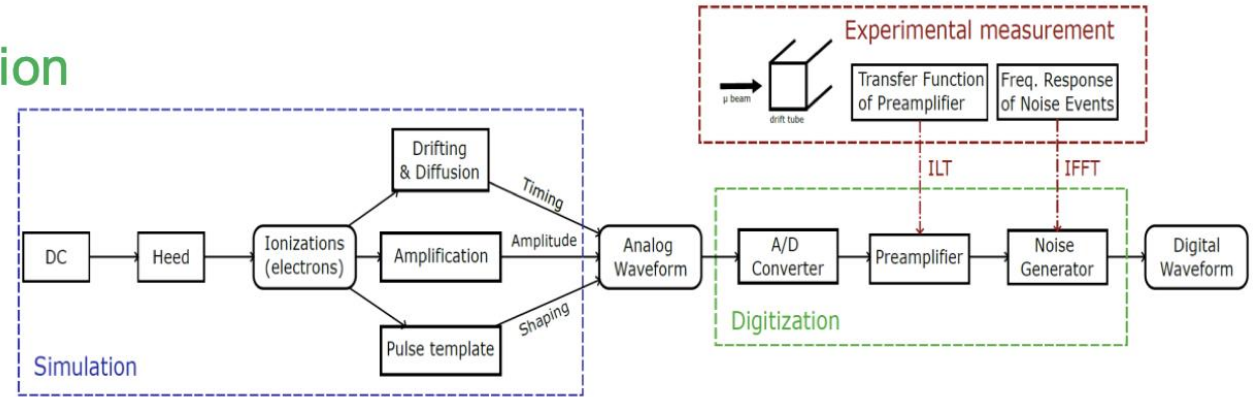

Multi-cell simulation

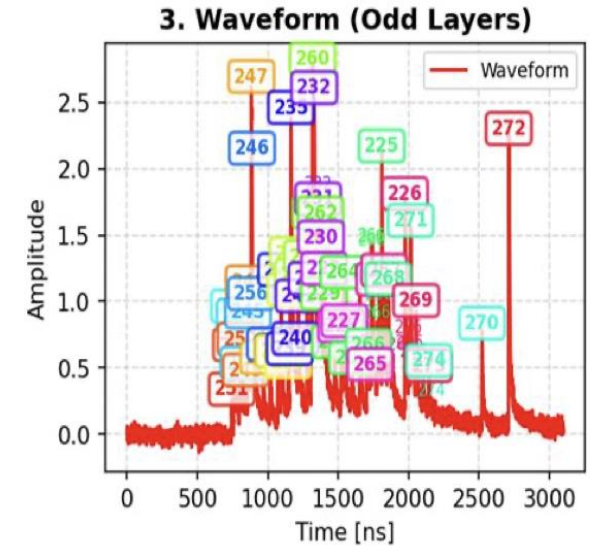
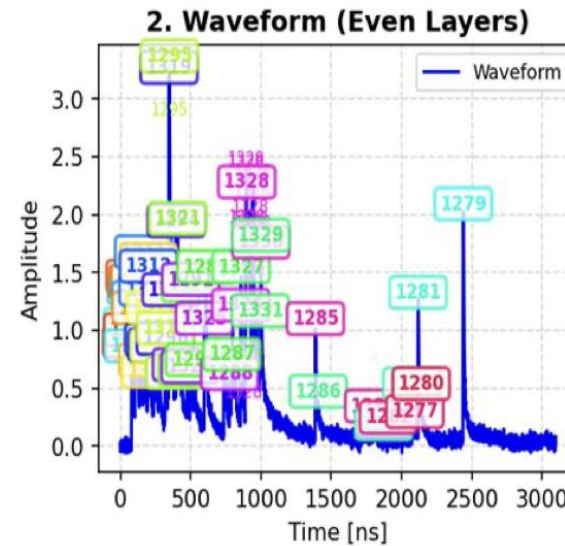
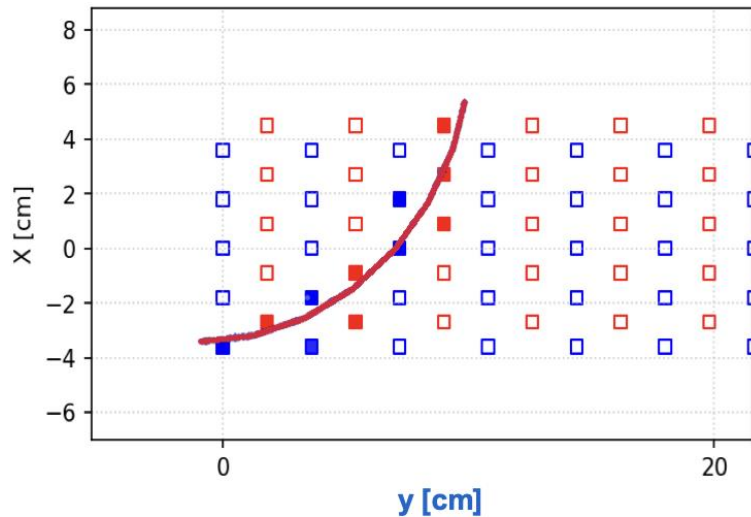



Technological and Interdisciplinary Research

Our Experience: Collaboration on medical applications

○ Ongoing activity on technology R&D

- Pixel readout ASIC for photon counting
- CZT Detectors for Gamma Cameras
- Items of interest for future joint developments
 - PET and time-of-flight technology



○ Activities INFN-IHEP in 2025

- Workshop at IHEP Jinan and INFN visit to the laboratories in Fall 2025
- Photon counting CT
 - Prototype ASIC received, front-end board and DAQ under development (IHEP Post-doc at INFN since 10/2024)
 - New funding at INFN (EIC) for CT using CMOS sensors
- CZT detectors for SPECT
 - New INFN project SPECTRE for development of CZT readout electronics

Our Experience: Collaboration on medical applications SPECT Readout Electronics

- **INFN funding from CSN5 for the development of system-ready readout solutions for SPECT, based on the CGEM-IT readout electronics (from the TIGER ASIC to the backend DAQ)**
- **A compact, modular, scalable solution for high-rate spectroscopic applications with CZT**
- **Ongoing activity to optimise the front-end board design, mechanics and sensor simulations:**
 - **CZT adapter card designed in Ferrara, now in fabrication**
 - **Mechanics and support for calibration and tests in X-ray facilities**
 - **Sensor studies and simulations with AllPixSquared**

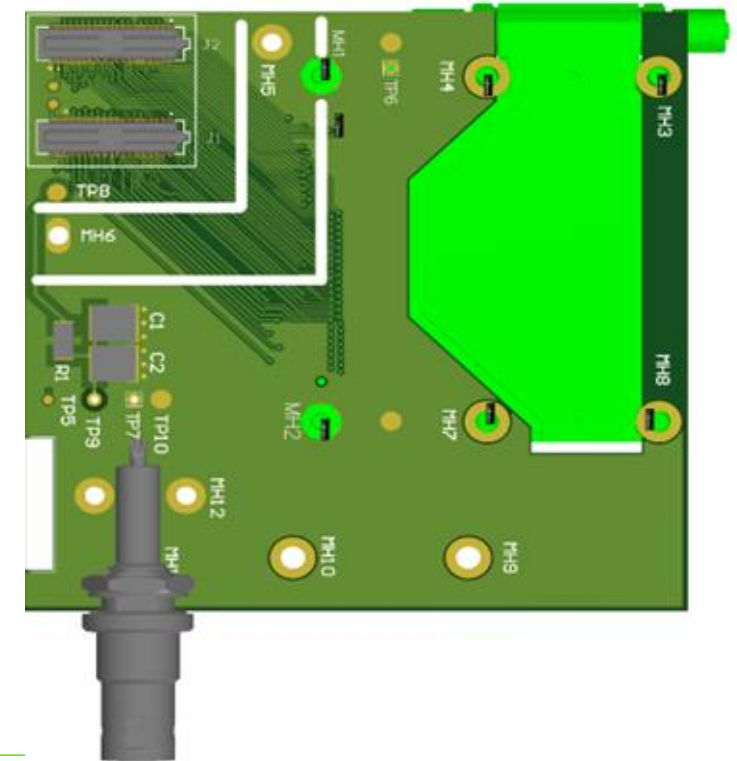
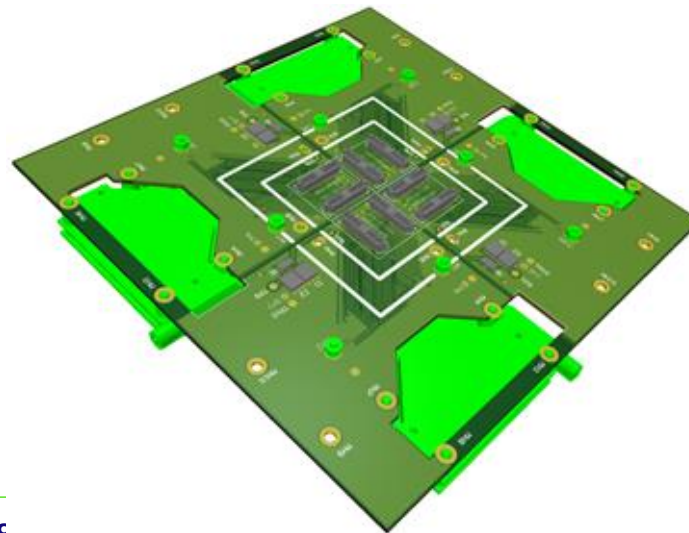
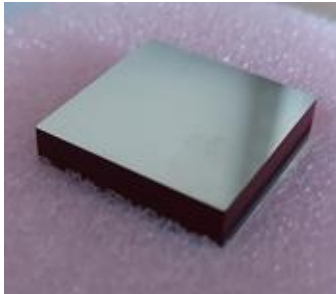
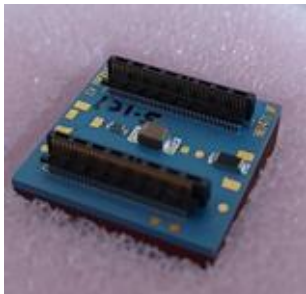
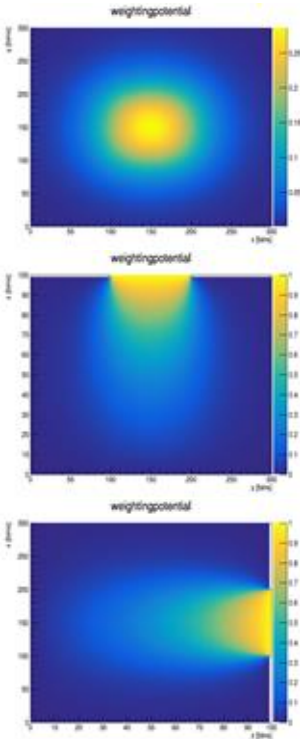

Our Experience: Collaboration on medical applications

Photon-Counting CT

- **Photon Counting Computer Tomography:** emerging technology, potential to dramatically improve clinical CT
- Requires **energy-resolving x-ray detectors** (instead of conventional energy-integrating detectors): counts the number of impinging photons to measure photon energy, providing:
 - higher contrast-to-noise ratio
 - improved spatial resolution
 - Optimised spectral imaging
- **INFN-IHEP Collaborative effort on the co-design of a multi-threshold multi-pixel ASIC for photon counting CT**
- **Front-end board design ongoing, test chip silicon produced with the LC3 ARCADIA Engineering Run**

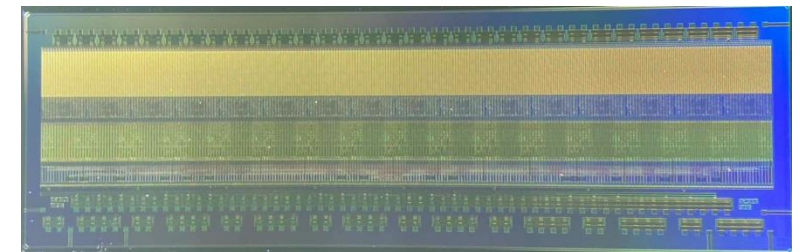
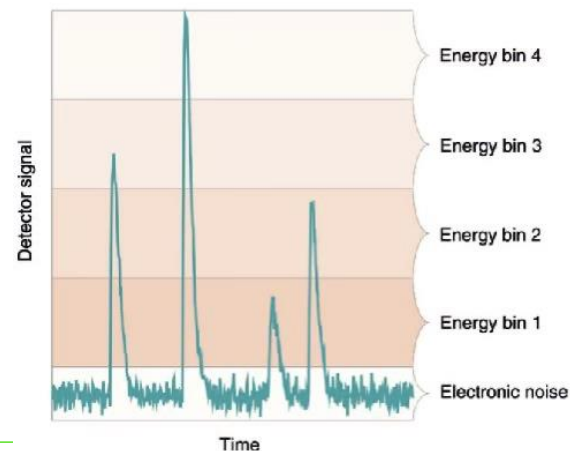
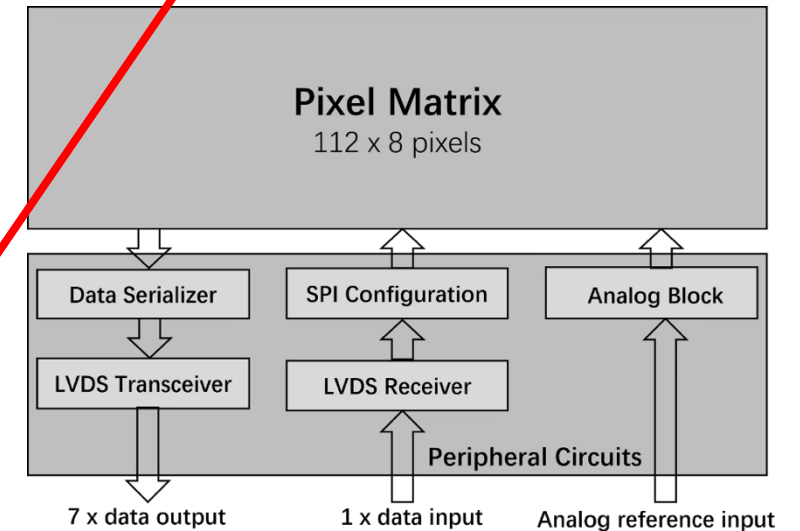
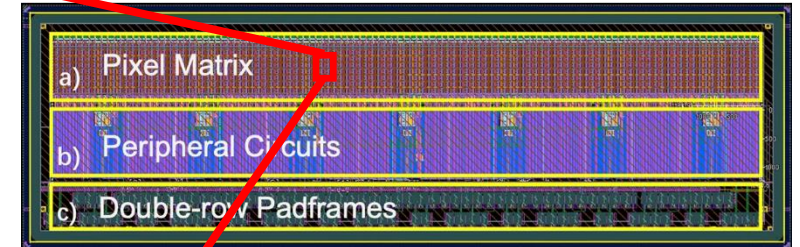
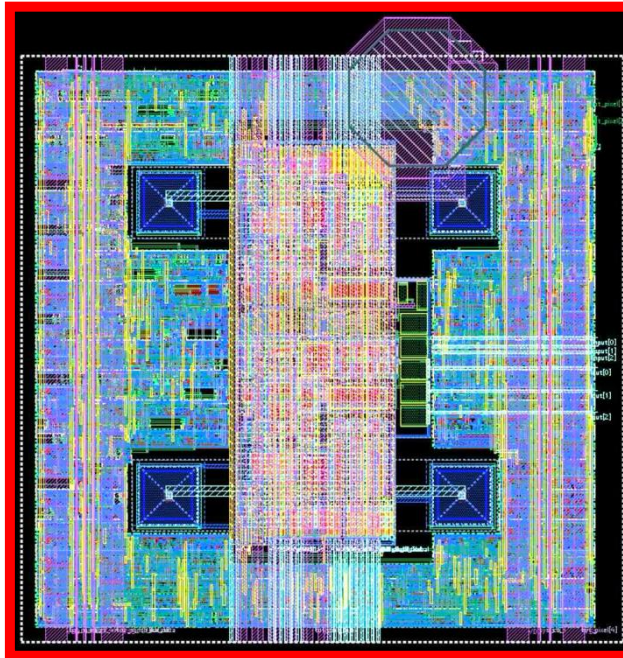

Our Experience



Exploiting cultural differences:

- The necessity to surmount the cultural gap and work together in the accomplishment of common objectives
→ **joint management**
- Deep and effective **communication**, needed for high level scientific discussions
- The creation of fully integrated Chinese – Italian working groups under a unique leadership in order to manage subsystems for which the joint exploitation of expertise is needed from both parties:
a goal achieved in our joint Collaborations.
- Improving integration of the training of our Post-doc and Doctoral Researchers: **mobility, more mobility**, once more... mobility!

Improving INFN cooperation with Chinese Institutions:

- Cooperation with the major Chinese Funding Agencies: a CAS GFA exists, not yet with NSFC (researchers mobility? joint fellowships/grants? joint R&D funding?) or UCAS (mobility!)

Building reciprocity and trust, openness, and promotion of knowledge



Mobility (bi-directional):

- mobility programme within the CAS-INFN GFA
- secondments within RISE H2020 Projects (e.g. BESIII, CGEM and FEST)

Joint Training:

- **Joint IHEP-INFN Fellowships**
- IHEP-INFN Agreement on the Doctoral Programme at Turin Polytechnic
- IHEP support to INFN related grants in the Doctoral Programmes of Ferrara and Turin Universities
- **joint management → joint training**

Geopolitical impact on EU-China co-operation

Recruitment:

- increased awareness of geopolitical standing by students and young researchers

We Shall Overcome:

- co-operation is valuable in itself
- open channels preserve unbiased communication and mutual understanding
- not all research fields experience geopolitical impact the same way
- adapting today for tomorrow's prosperity
- focus on Cultural Heritage: common roots from the past support tomorrow's co-operation

Long term widespread collaboration
is matter of trust and friendship

And of taking care of young and
fellow researcher

The legacy of these years...

... **Rinaldo Baldini's legacy**...

... are the foundations of our future together





谢谢
